

**Air Fryer**

**- FOR INDOOR HOUSEHOLD USE ONLY -**



**IMPORTANT, RETAIN FOR FUTURE REFERENCE: READ CAREFULLY**

**USING INSTRUCTION**

## **INTRODUCTION**

This all now Hot-air fryer provides an easy and healthy way of preparing your favorite ingredients. By using hot rapid air circulation and a top grill, it is able to make numerous dishes. The best part is that the Hot-air fryer heats food at all directions and most of the ingredients do not need any oil.

## **SAVE THESE INSTRUCTIONS**

This appliance is not intended to be used in household and similar applications such as:

- staff kitchen areas in shops, offices and other working environments;
- farm houses;
- by clients in hotels, motels and other residential type environments;
- bed and breakfast type environments.

## **IMPORTANT SAFEGUARDS**

When using electrical appliances, basic safety precautions should always be followed including the following:

1. Read all instructions.
2. Do not touch hot surfaces.
3. To protect against electric shock do not immerse cord, plugs, or base in water or other liquid.
4. **WARNING:** This electrical appliance contains a heating function. Surfaces, also different than the functional surfaces, can develop high temperatures. Since temperatures are differently perceived by different persons, this equipment shall be used with **CAUTION**. The equipment shall be touch only at intended handles and gripping surfaces, and use heat protection like gloves or similar. Surfaces other than intended gripping surfaces shall get sufficiently time to the cool down before getting touched.
5. Unplug from outlet when not in use and before cleaning. Allow to cool before putting on or taking off parts.
6. Type Y: If the supply cord is damaged, it must be replaced by the manufacturer, its service agent or similarly qualified persons in order to avoid a hazard.
7. The use of accessory attachments not recommended by the appliance manufacturer may cause injuries.
8. Do not use outdoors
9. Do not let cord hang over edge of table or counter, or touch hot surfaces.
10. Do not place on or near a hot gas or electric burner, or in a heated oven.
11. Extreme caution must be used when moving an appliance containing hot oil or other hot liquids.
12. Always attach plug to appliance first, then plug cord in the wall outlet. To disconnect, turn any control to "off," then remove plug from wall outlet.
13. Do not use appliance for other than intended use.
14. This appliance can be used by children aged from 8 years and above and persons with reduced physical, sensory or mental capabilities or lack of experience and knowledge if they have been given supervision or instruction concerning use of the appliance in a safe way and understand the hazards involved. Children shall not play with the appliance. Cleaning and user maintenance shall not be made by children unless they are old than 8 and supervised.
15. Keep the appliance and its cord out of reach of children less than 8 years.
16. The appliances are not intended to be operated by means of an external timer or separate remote-control system.

**TECHNICAL DATA:**

- Voltage:220-240V ~50/60Hz
- Wattage: 1500 W
- Capacity of basket: 4.5 L
- Adjustable temperature:80°C-200°C
- Timer (0-60 min)

**GENERAL DESCRIPTION (Fig.1)**

- 1. Control panel
- 2. Basket
- 3. Single pot handle
- 4. Basket handle
- 5. Pot
- 6. Main housing
- 7. Air outlet
- 8. Main cord (Electrical cord)

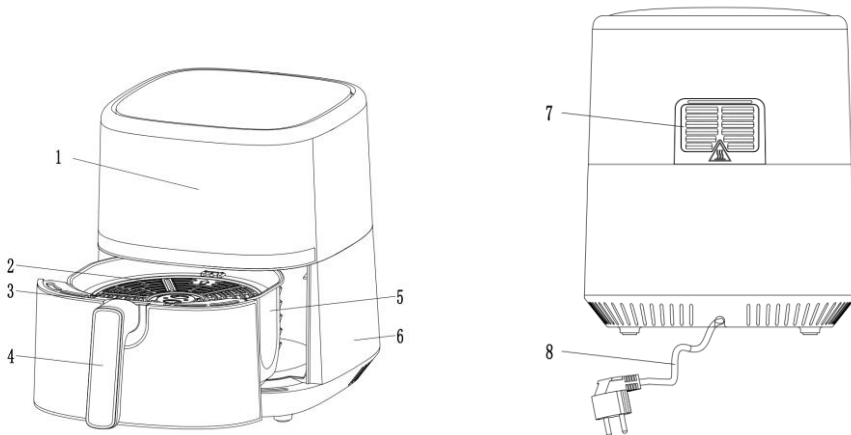

Fig.1



Fig.2



Fig.3

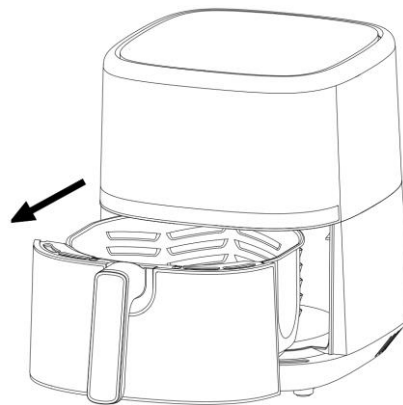

Fig.4

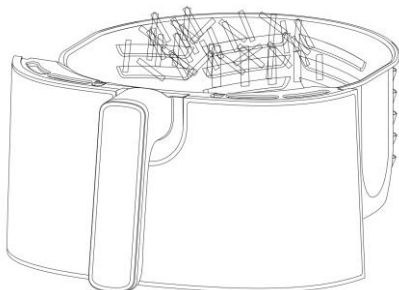

Fig.5

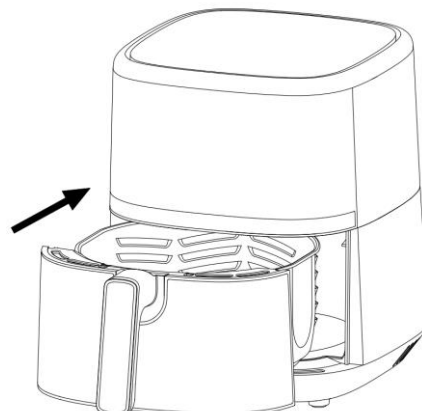

Fig.6

## **Important !**

### **Danger**

-This appliance can be used by children aged from 8 years and above and persons with reduced physical, sensory or mental capabilities or lack of experience and knowledge if they have been given supervision or instruction concerning use of the appliance in a safe way and understand the hazards involved. Children shall not play with the appliance. Cleaning and user maintenance shall not be made by children unless they are older than 8 and supervised.

-Keep the appliance and its cord out of reach of children less than 8 years.

-Never immerse the housing, which contains electrical components and the heating elements, in water nor rinse it under the tap.

-Do not let any water or other liquid enter the appliance to prevent electric shock.

-Always put the ingredients to be fried in the basket, to prevent it from coming into contact with the heating elements.

-Do not cover the air inlet and the air outer openings while the appliance is operating.

-Do not fill the pot with oil as this may cause a fire hazard.

-Never touch the inside of the appliance while it is operating.

The temperature of accessible surfaces may be high when the appliance is operating.

### **WARNING**

- Check if the voltage indicated on the appliance fits the local mains voltage.

- Do not use the appliance if there is any damage on plug, mains cord or other parts.

- Do not go to any unauthorized person to replace or fix damaged main cord.

- Keep the mains cord away from hot surfaces.

- Do not plug in the appliance or operate the control panel with wet hands.

- Do not place the appliance against a wall or against other appliances. Leave at least 10 cm free space on the back and sides and 10cm free space above the appliance.

Do not place anything on top of the appliance.

- Do not use the appliance for any other purpose than described in this manual.

- Do not let the appliance operate unattended.

- During hot air frying, hot steam is released through the air outlet openings, Keep your hands and face at a safe distance from the steam and from the air outlet openings.

Also be careful of hot steam and air when you remove the pot from the appliance.

-Any accessible surfaces may become hot during use (Fig.2)

- Immediately unplug the appliance if you see dark smoke coming out of the appliance.

Wait for the smoke emission to stop before you remove the pot from the appliance.

### **Caution**

- Ensure the appliance is placed on a horizontal, even and stable surface.

- This appliance is designed for household use only. It may not be suitable to be safely used in environments such as staff kitchens, farms, motels, and other non-residential environments. Nor is it intended to be used by clients in hotels, motels, bed and breakfasts and other residential environments.

- If the appliance is used improperly or for professional or semi-professional purposes or it is not used according to the instructions in the user manual, the guarantee becomes invalid and we could refuse any liability for damage caused.

-Always unplug the appliance while not using.

-The appliance needs approximately 30 minutes to cool down for handle or cleaning safely.

## **Before first use**

1. Remove all packaging materials.
2. Remove any stickers or labels from the appliance.
3. Thoroughly clean the basket and pot with hot water, some washing-up liquid and a non-abrasive sponge.
4. Wipe inside and outside of the appliance with a moist cloth.

This is an oil-free fryer that works on hot air, do not fill the pot with oil or frying fat directly.

## **Preparing for use**

1. Place the appliance on a stable, horizontal and even surface.

Do not place the appliance on non-heat-resistant surface.

2. Place the basket in the pot (Fig.3).

Do not fill the pot with oil or any other liquid.

Do not put anything on top of the appliance, the airflow will be disrupted and affects the hot air frying result.

## **USING THE APPLIANCE**

The oil-free can prepare a large range of ingredients.

### **Hot air frying**

1. Connect the mains plug into an earthed wall socket.
2. Carefully pull the pot out of the Hot-air fryer (Fig.6)
3. Put the ingredients in the basket. (Fig.5)
4. Slide the pot back into the Hot-air fryer (Fig 4)

Noting to carefully align with the guides in the body of the fryer.

Never use the pot without the shelf in it.

**Caution: Do not touch the pot during and sometime after use, as it gets very hot. Only hold the pot by the handle.**

5. Determine the required preparation time for the ingredient (see section 'Settings' in this chapter).

6. Some ingredients require shaking halfway through the preparation time (see section "Settings" in this chapter). To shake the ingredients, pull the pot out of the appliance by the handle and shake it. Then slide the pot back into the air fryer

*Tip: If you set the timer to half the preparation time, you hear the timer buzzer when you have to shake the ingredients. However, this means that you have to set the timer again to the remaining preparation time after shaking.*

7. When you hear the timer buzzer, the set preparation time has elapsed. Pull the pot out of the appliance

**Note: You can also switch off the appliance manually. To do this, set the time to 1.**

8. Check if the ingredients are ready.

If the ingredients are not ready yet, simply slide the pot back into the appliance and set the timer to a few extra minutes.

9. To remove ingredients (e.g. fries), pull the pot out of the Hot-air fryer and place it on a flat surface.

**Do not turn the pot upside down still attached to it, as any excess oil that has collected on the bottom of the pot will leak onto the ingredients.**

**The pot and the ingredients are hot. Depending on the type of the ingredients in the air fryer, steam may escape from the pot.**

10. Empty the shelf into a bowl or onto a plate.

11. When a batch of ingredients is ready, the Hot-air fryer is instantly ready for preparing another batch.

## CONTROL PANEL INSTRUCTIONS



### Operation Instructions:

Key  –Power Key

Once the Basket and pot are properly placed in the main housing, the Power light will be illuminated. Selecting the power key for 3 seconds will make the unit default temperature 200°C, while the cooking time will be set to 15 minutes. Selecting the Power key a second time will start the cooking process. Pressing the power key for 3 seconds to close the entire device during cooking. All the lights go out, the fan stops working.

Note: During cooking, you can touch the keys to control the pause and start of cooking.

Key  –Preset Key

Selecting the “” Preset key enables you to scroll through the 8 popular food choices. Once selected, the predetermined time and cooking temperature function begins.

Key  & Key  –Timer/Temperature Control Keys

Timer Control Buttons

The “+” and “-” symbols enable you to add or decrease cooking time, one minute at a time. Keeping the button held down will rapidly change the time.

Temperature Control Buttons

The “+” and “-” symbols enable you to add or decrease cooking temperature 5°C at a time. Keeping the button held down will rapidly change the temperature. Temperature Control range: 80°C-200°C

Indicator light “” Fan indicator

The center circle is heating lamp, Around 5 lamp lights for motor work

Indicator light “  ” Temperature light

Indicator light “  ” Timer light

Indicator light “ **min** ” Timer indicator

Indicator light “         ” Recipe indicator

**Settings**

This table below will help you to select the basic settings for the ingredients.

Note: Keep in mind that these settings are indications. As ingredients differ in origin, size, shape as well as brand, we cannot guarantee the best setting for your ingredients.

Because the Rapid Air technology instantly reheats the air inside the appliance instantly Pull the pot briefly out of the appliance during hot air frying barely disturbs the process.

**Tips**

- *Smaller ingredients usually require a slightly shorter preparation time than larger ingredients.*
- *A larger amount of ingredients only requires a slightly longer preparation time, a smaller amount of ingredients only requires a slightly shorter preparation time.*
- *Shaking smaller ingredients halfway through the preparation time optimizes the end result and can help prevent unevenly fried ingredients.*
- *Add some oil to fresh potatoes for a crispy result. Fry your ingredients in the Hot-air fryer within a few minutes after you added the oil.*
- *Do not prepare extremely greasy ingredients such as sausages in the Hot-air fryer.*
- *Snacks that can be prepared in a oven can also be prepared in the Hot-air fryer*
- *The optimal amount for preparing crispy fries is 500 grams.*
- *Use pre-made dough to prepare filled snacks quickly and easily. Pre-made dough also requires a shorter preparation time than home-made dough.*
- *Place a baking tin or oven dish in the Hot-air fryer basket if you want to bake a cake or quiche or if you want to fry fragile ingredients or filled ingredients*
- *You can also use the Hot-air fryer to reheat ingredients. To reheat ingredients, set the temperature to 150°C for up to 10 minutes.*

		Time	Steak	Wings	Shrimp	Fish	Snacks	Fries	Bake	Vegetables
Temperature	80-200 °C	1-60 min	180 16	180 25	180 12	180 18	200 20	200 17	160 17	160 17
Min-max Amount(g)			100-600	100-500	100-500	100-500	100-500	100-500	100-500	100-500

**Note:**

- 1. Add 3 minutes to the preparation time when you start frying while the Hot-air fryer is still cold;**
- 2. Turn or shake once during baking.**

## Cleaning

Clean the appliance after every use.

**The pot and the non-stick coating shelf. Do not use metal kitchen utensils or abrasive cleaning materials to clean them, as this may damage the non-stick coating.**

1. Remove the mains plug from the wall socket and let the appliance cool down.

Note: Remove the pot to let the Hot-air fryer cool down more quickly.

2. Wipe the outside of the appliance with a moist cloth.

3. Clean the pot and basket with hot water, some washing-up liquid and a non-abrasive sponge.

You can use degreasing liquid to remove any remaining dirt.

*Tip: If dirt is stuck to the basket or the bottom of the pot, fill the pot with hot water with some washing-up liquid. Put the basket in the pot and let the pot and the basket soak for approximately 10 minutes.*

4. Clean the inside of the appliance with hot water and non-abrasive sponge.

5. Clean the heating element with a cleaning brush to remove any food residues.

## Storage

1 Unplug the appliance and let it cool down.

2 Make sure all parts are clean and dry.

## Environment

Do not throw away the appliance with the normal household waste when it is exhausted, but hand it in at an official collection point for recycling. By doing this, you help to preserve the environment

## Troubleshooting

problem	Possible cause	Solution
The Hot-air fryer does not work	The appliance is not plugged in.	Put the mains plug in an earthed wall socket.
	The appliance is not plugged in.	Set the timer key to the required preparation time to switch on the appliance.
The ingredients fried with the air fryer are not done.	The amount of ingredients in the basket is too big.	Put smaller batches of ingredients in the basket. Smaller batches are fried more evenly.
	The set temperature is too low.	Set the temperature key to the required temperature setting (see section 'settings' in chapter 'Using the appliance').
	The preparation time is too short.	Set the timer to the required preparation time (see section 'Settings' in chapter 'Using the appliance').
The ingredients are fried unevenly in the air fryer.	Certain types of ingredients need to be shaken halfway through the preparation time.	Ingredients that lie on top of or across each other (e.g. fries) need to be shaken halfway through the preparation time. See section 'Settings' in chapter 'Using the appliance'.

Fried snacks are not crispy when they come out of the air fryer.	You used a type of snacks meant to be prepared in a traditional deep fryer.	Use oven snacks or lightly brush some oil onto the snacks for a crispier result.
I cannot slide the pan into the appliance properly.	There are too much ingredients in the pot.	Do not fill the pot beyond the MAX indication.
	The pot is not placed correctly.	Push the pot again in the correct direction.
White smoke comes out of the appliance.	You are preparing greasy ingredients.	When you fry greasy ingredients in the air fryer, a large amount of oil will leak into the pot. The oil produces white smoke and the pot may heat up more than usual. This does not affect the appliance or the end result.
	The pot still contains grease residues from previous use.	White smoke is caused by grease heating up in the pan. make sure you clean the pan properly after each use.
Fresh fries are fried unevenly in the air fryer.	You did not use the right potato type.	Use fresh potatoes and make sure they stay firm during frying.
	You did not rinse the potato sticks properly before you fried them.	Rinse the potato sticks properly to remove starch from the outside of the sticks.
Fresh fries are not crispy when they come out of the air fryer.	The crispiness of the fries depends on the amount of oil and water in the fries.	Make sure you dry the potato sticks properly before you add the oil.
		Cut the potato sticks smaller for a crispier result.
		Add slightly more oil for a crispier result.

### Correct Disposal of this product



This marking indicates that this product should not be disposed with other household wastes throughout the EU. To prevent possible harm to the environment or human health from uncontrolled waste disposal, recycle it responsibly to promote the sustainable reuse of material resources. To return your used device, please use the return and collection systems or contact the retailer where the product was purchased. They can take this product for environmental safe recycling.