

Playhouse Swing

Assembling Instruction

ZZIP137MS

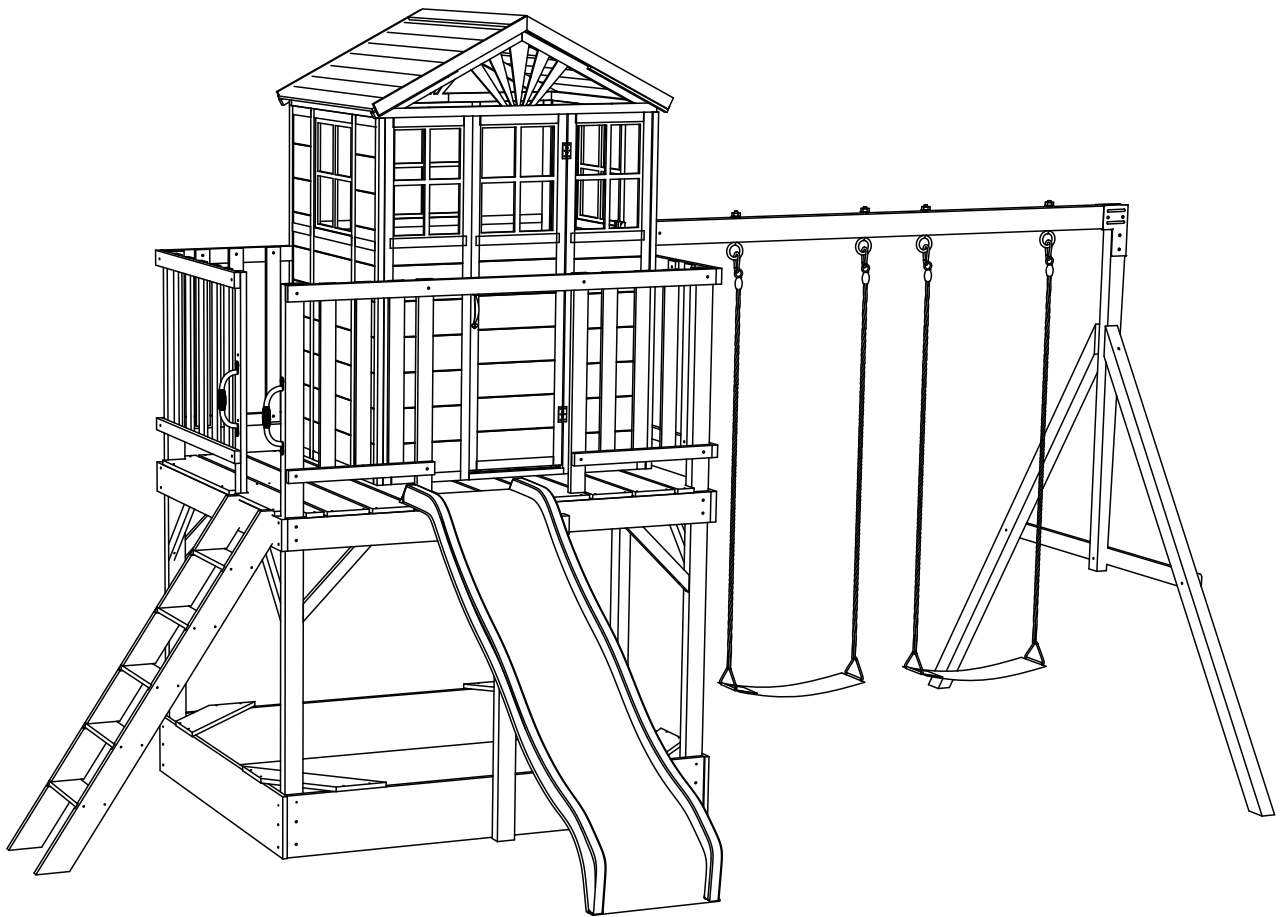

ATTENTION

Thanks for choosing our product.

There will be 3 boxes in total for this whole product.



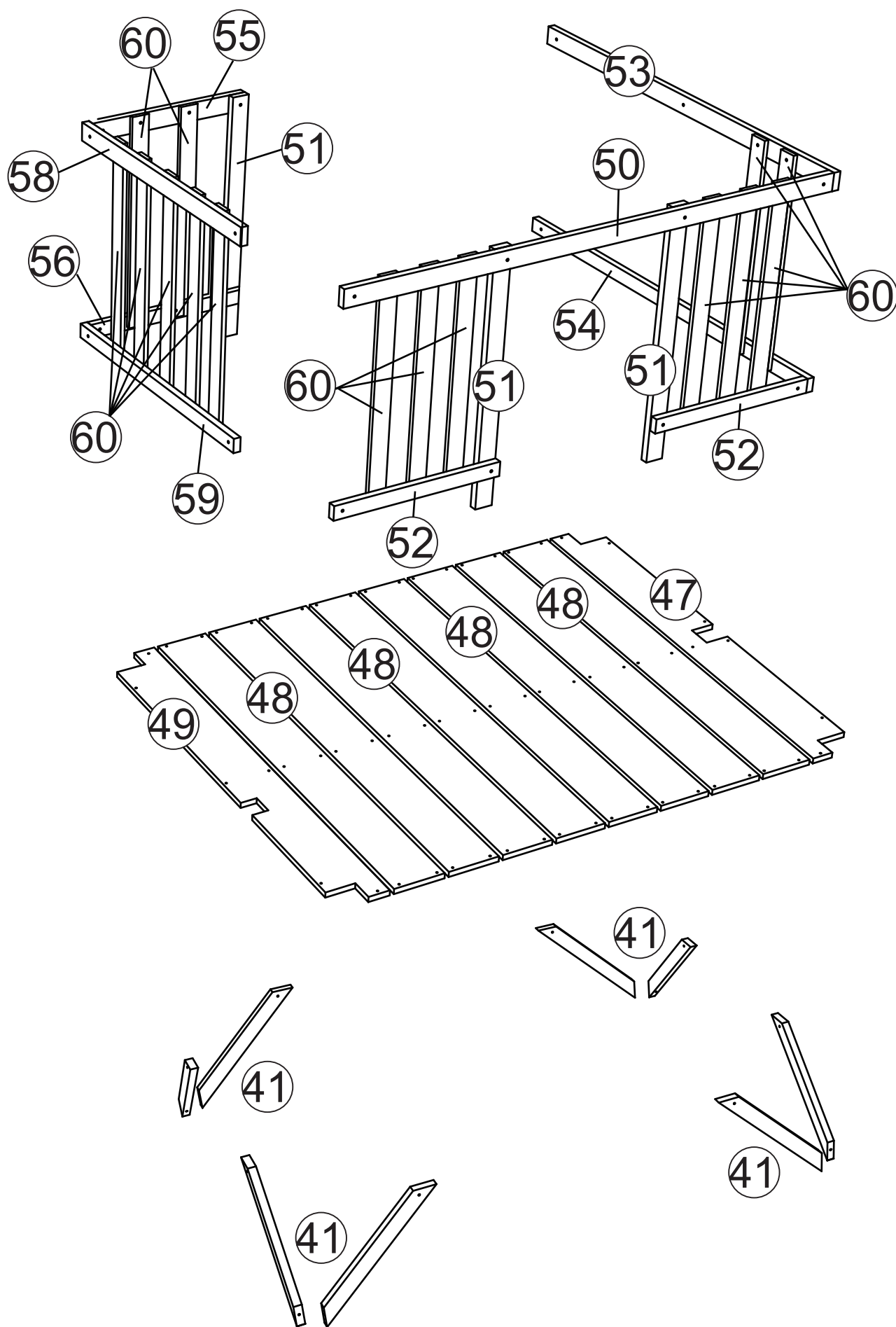

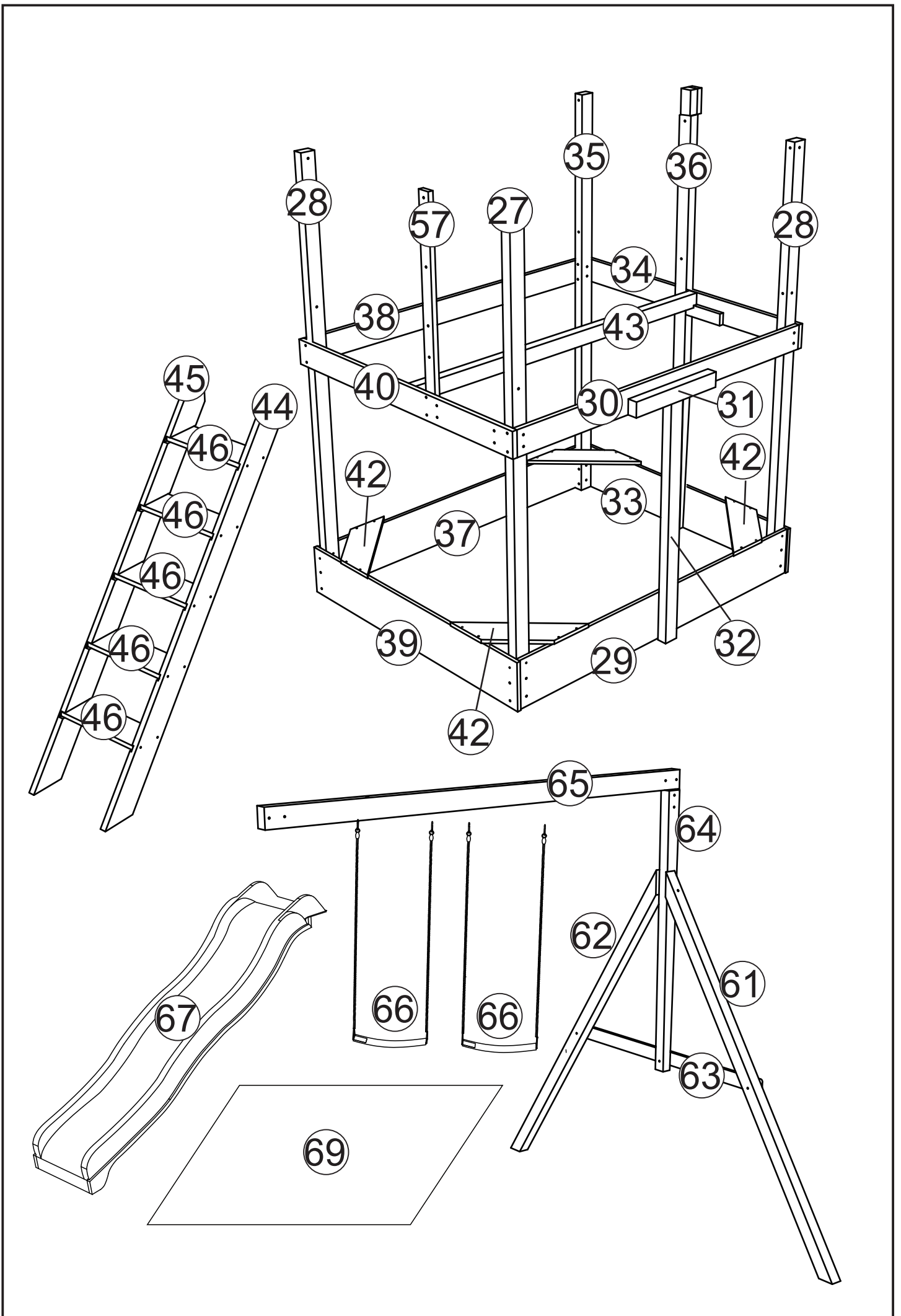

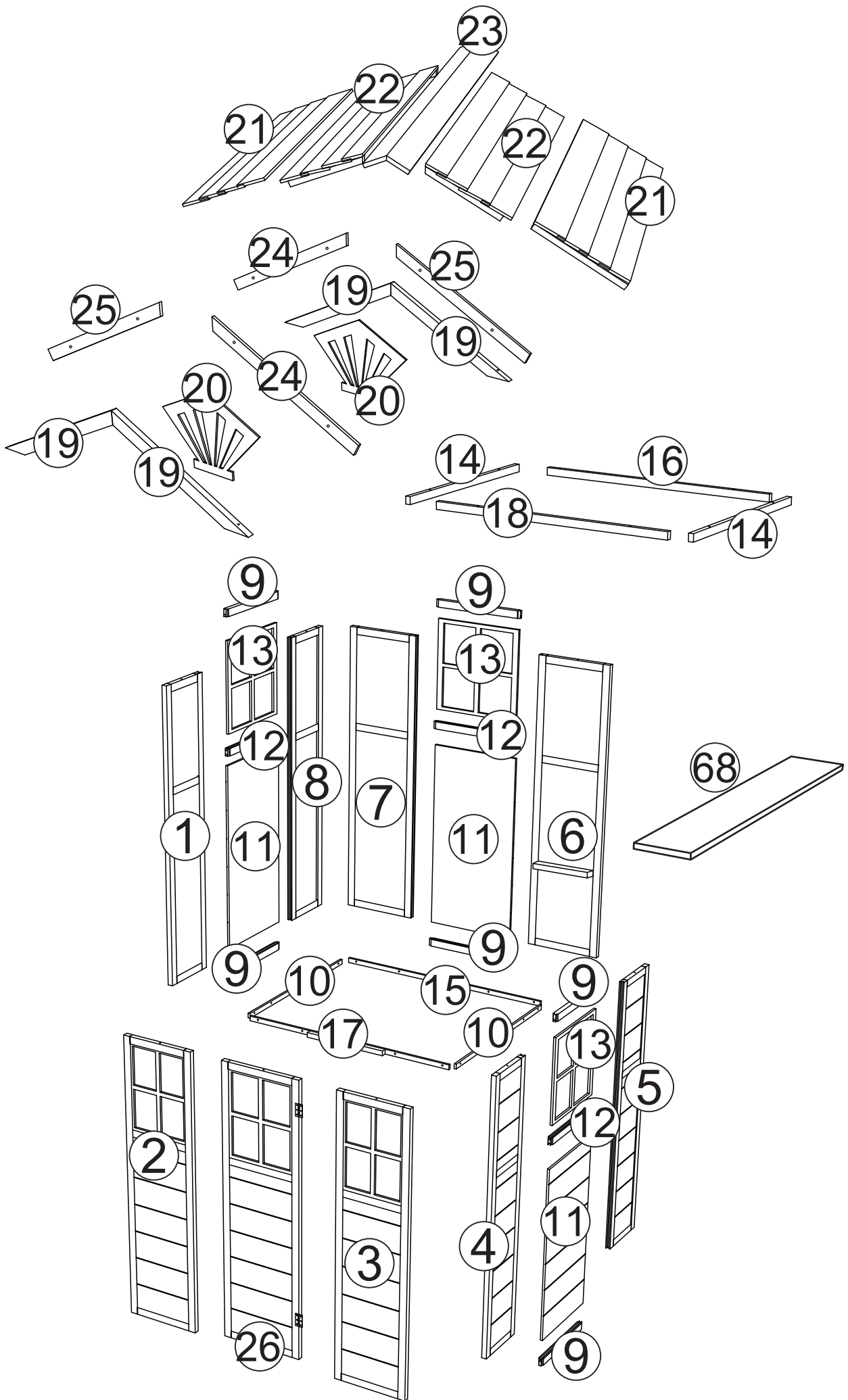









(We will hand over all the boxes to the logistics provider together, but they may transport them separately, which may result in inconsistent arrival times of the boxes.)

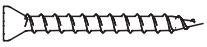

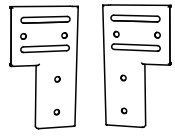

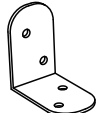
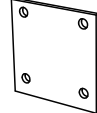

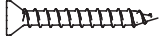
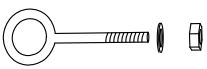
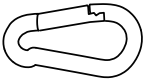

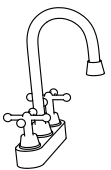
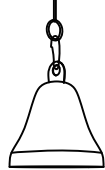
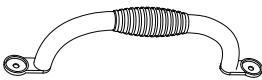
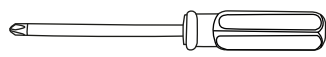



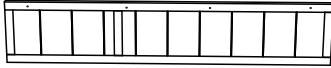
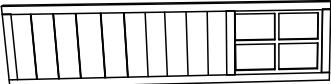
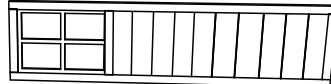
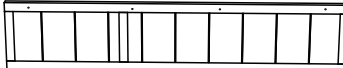
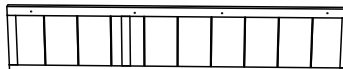
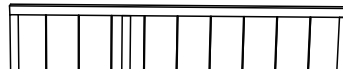



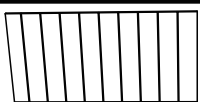









BOX- A

| | | | |
|---|--|--|---|
| <p>A x53 M4x40</p>  | <p>B x 37 M4x20</p>  | <p>C x 8 M8x30</p>  | <p>D x94 M4x30</p>  |
| <p>E x32 M3x10</p>  | <p>F x 30 M6X60</p>  | <p>G x 69</p>  | <p>H x13 M6X50</p>  |
| <p>I x 1 M4x60</p>  | <p>J x16 M6X70</p>  | <p>K x 28 M4x35</p>  | <p>L x 2</p>  |
| <p>M x16 M6X40</p>  | <p>N x30 M4X25</p>  | <p>O x 4</p>  | <p>P x2</p>  |
| <p>Q x 2 M6X20</p>  | <p>R x 8</p>  | <p>S x10 M4x50</p>  | <p>T x4</p>  |
| <p>U x 4</p>  | | <p>V x1</p>  | <p>W x1</p>  |
|  | <p>X x1</p> |  | <p>Y x1</p> |
|  | <p>Z x2</p>  | | |

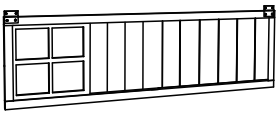

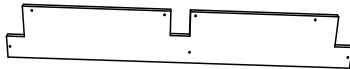
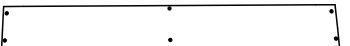
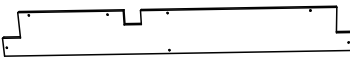

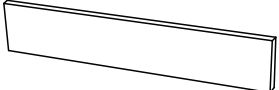



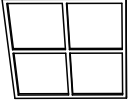

BOX- A

| NO. | PARTS | QTY |
|-----|---|-----|
| ① |  | 1 |
| ② |  | 1 |
| ③ |  | 1 |
| ④ |  | 1 |
| ⑤ |  | 1 |
| ⑥ |  | 1 |
| ⑦ |  | 1 |
| ⑧ |  | 1 |
| ⑨ |  | 6 |
| ⑪ |  | 3 |
| ⑫ |  | 3 |
| ⑭ |  | 2 |
| ⑮ |  | 1 |



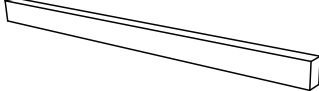



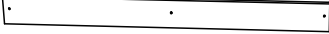
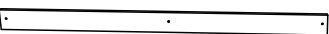

BOX- A

| NO. | PARTS | QTY |
|-----|---|-----|
| ⑯ |  | 1 |
| ⑰ |  | 1 |
| ⑲ |  | 4 |
| ⑳ |  | 1 |
| ㉑ |  | 2 |
| ㉒ |  | 2 |
| ㉔ |  | 1 |
| ㉖ |  | 4 |
| ㉗ |  | 1 |
| ㉘ |  | 8 |
| ㉙ |  | 1 |
| ① |  | 3 |
| ② |  | 1 |
| ③ |  | 1 |

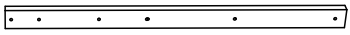
BOX- B

| NO. | PARTS | QTY |
|-----|---|-----|
| 10 |  | 2 |
| 13 |  | 3 |
| 18 |  | 1 |
| 20 |  | 2 |
| 21 |  | 2 |
| 22 |  | 2 |
| 31 |  | 1 |
| 32 |  | 1 |
| 40 |  | 1 |
| 45 |  | 1 |
| 46 |  | 5 |

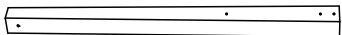
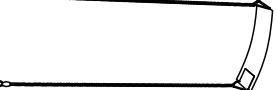
BOX- B

| NO. | PARTS | QTY |
|-----|---|-----|
| 50 |  | 1 |
| 53 |  | 1 |
| 54 |  | 1 |
| 56 |  | 1 |
| 57 |  | 1 |
| 58 |  | 1 |
| 60 |  | 4 |
| 63 |  | 1 |
| 64 |  | 1 |
| 66 |  | 2 |
| 67 |  | 1 |

BOX- C

| NO. | PARTS | QTY |
|-----|-------|-----|
| 27 | | 1 |
| 28 | | 2 |
| 29 | | 1 |
| 30 | | 1 |
| 33 | | 1 |
| 34 | | 1 |
| 35 | | 1 |
| 36 | | 1 |
| 37 | | 1 |
| 38 | | 1 |
| 39 | | 1 |

BOX- C

| NO. | PARTS | QTY |
|-----|-------|-----|
| 41 | | 8 |
| 43 | | 1 |
| 44 | | 1 |
| 51 | | 3 |
| 52 | | 2 |
| 55 | | 1 |
| 59 | | 1 |
| 60 | | 8 |
| 61 | | 1 |
| 62 | | 1 |
| 65 | | 1 |

A x 4
M4x40

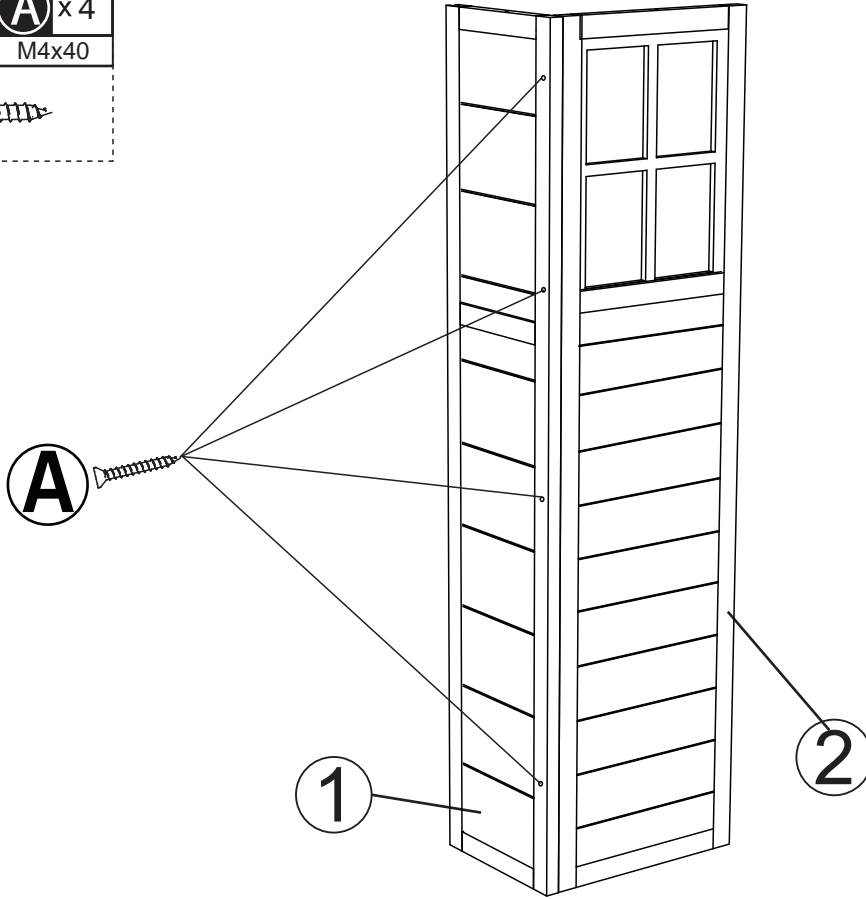

A x 4
M4x40

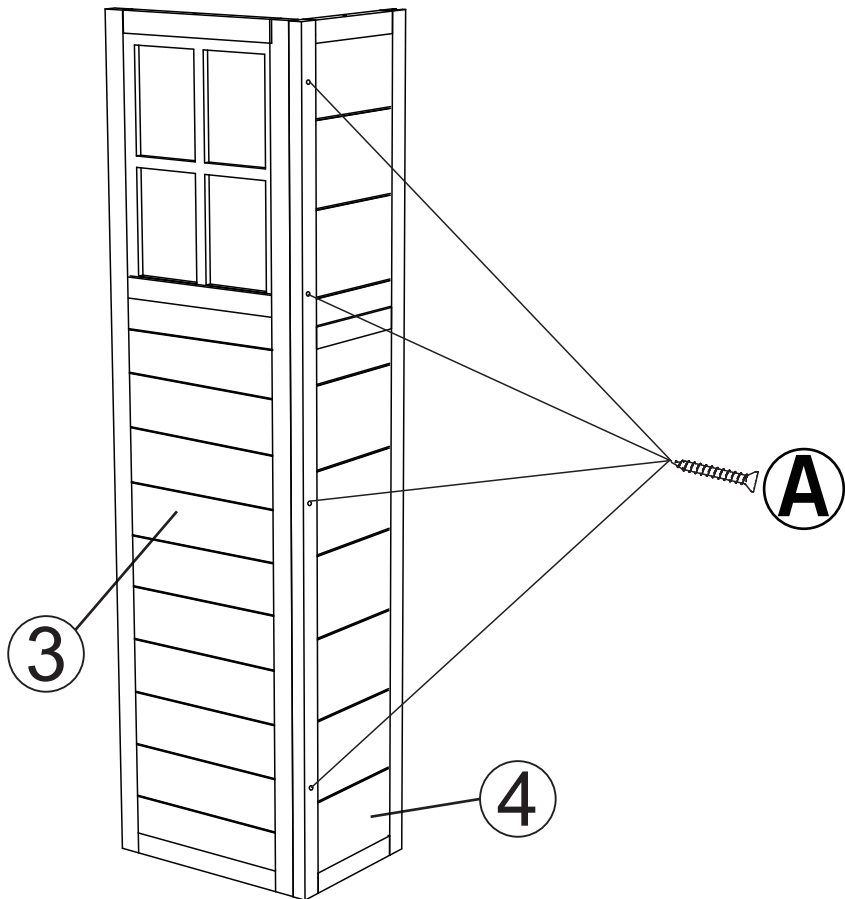

A x 4
M4x40

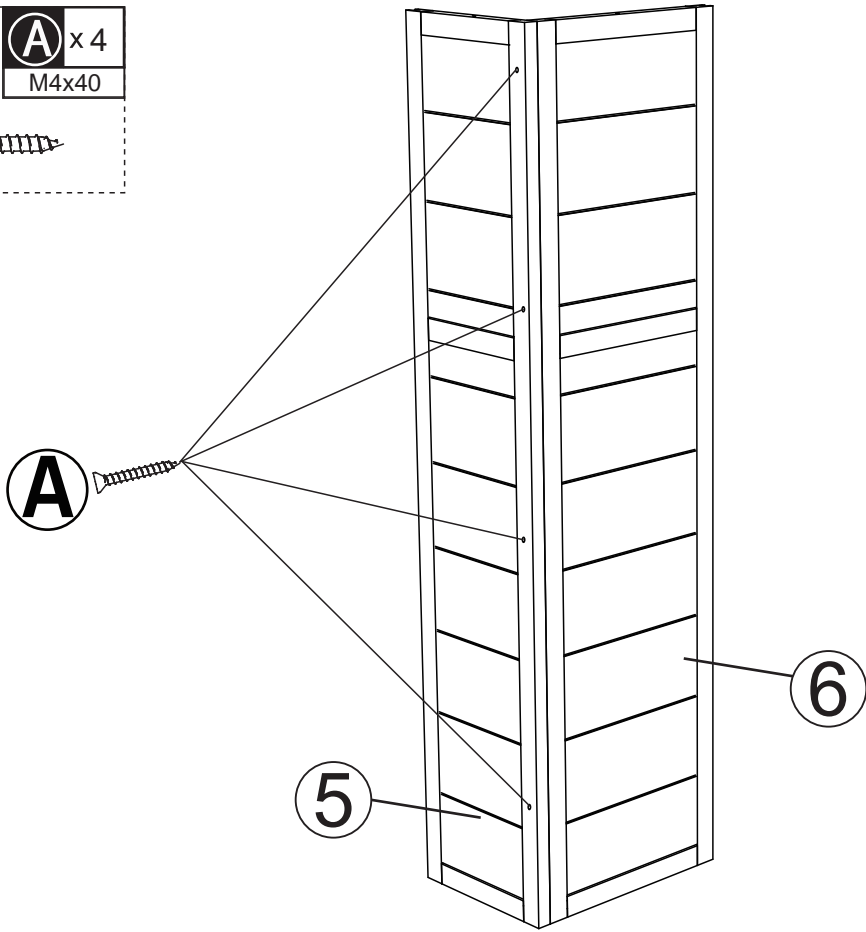

A x 4
M4x40

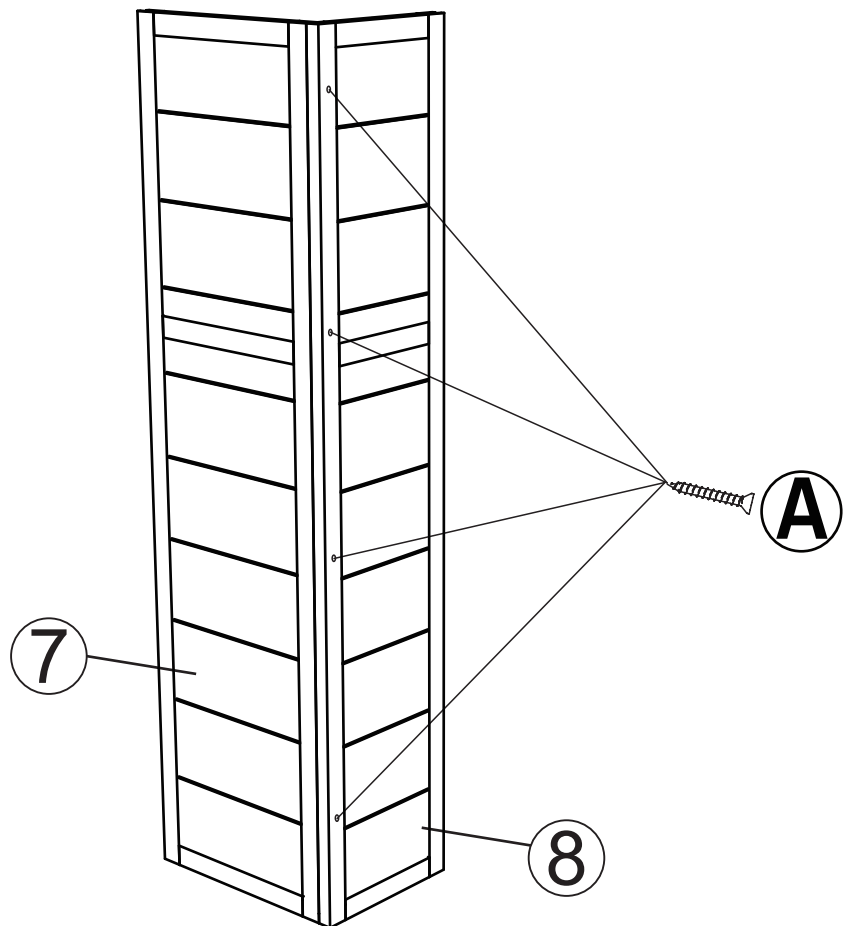
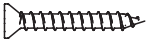

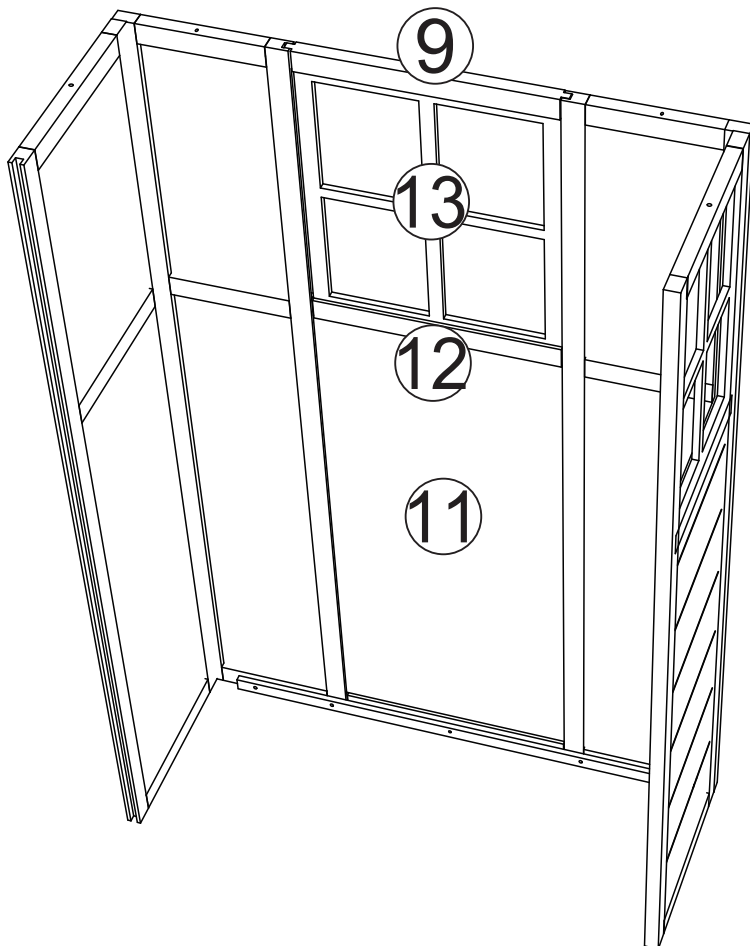
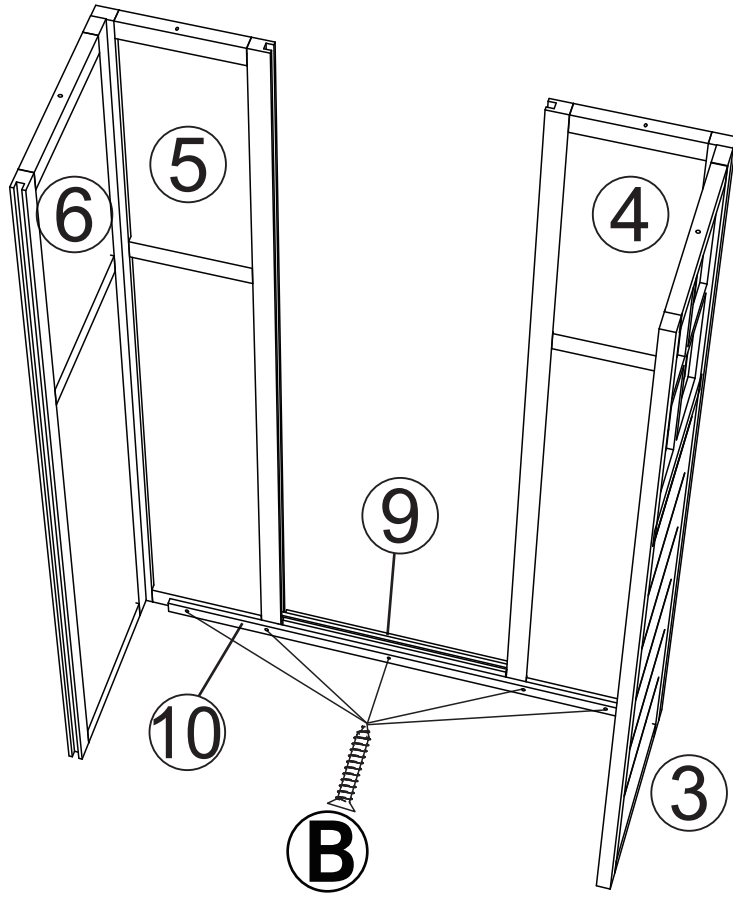
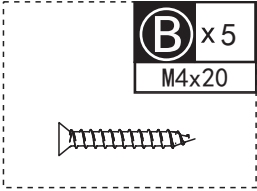

C x 2
M8x30

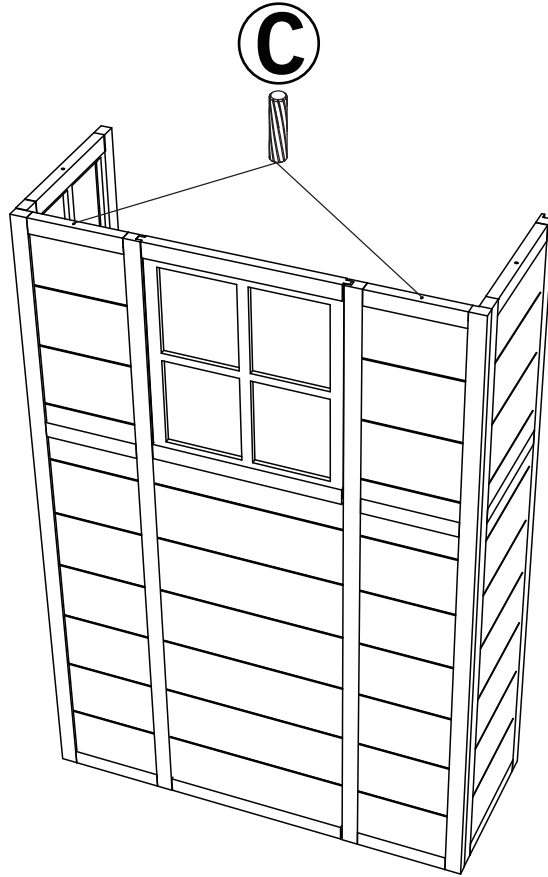

A x 3
M4x40

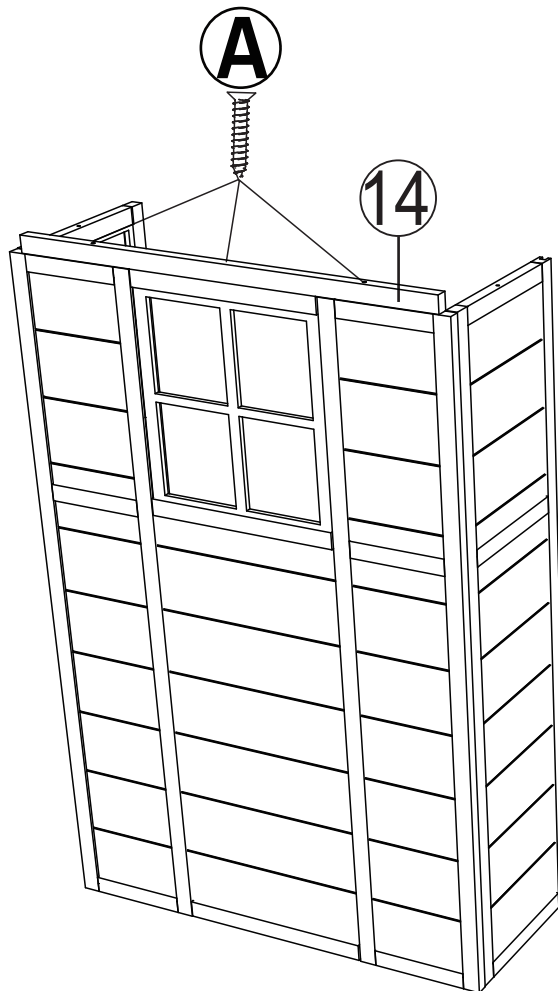

B x 5
M4x20

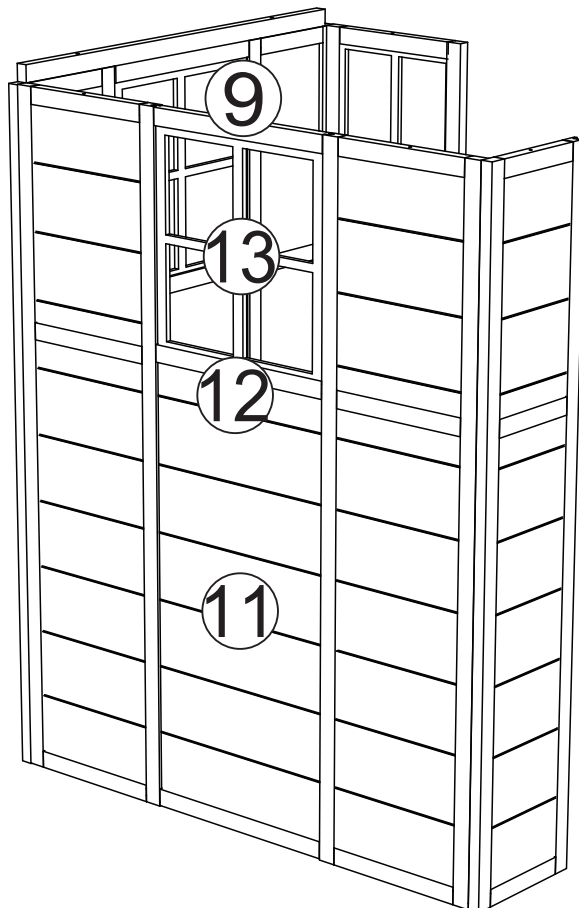
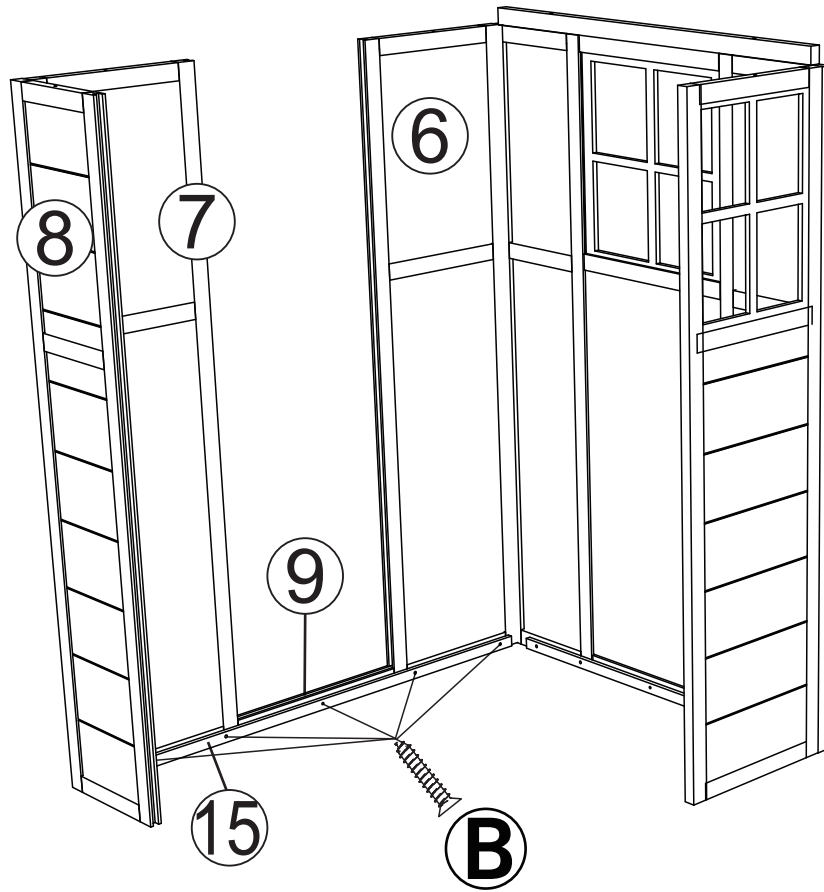

C x 2
M8x30

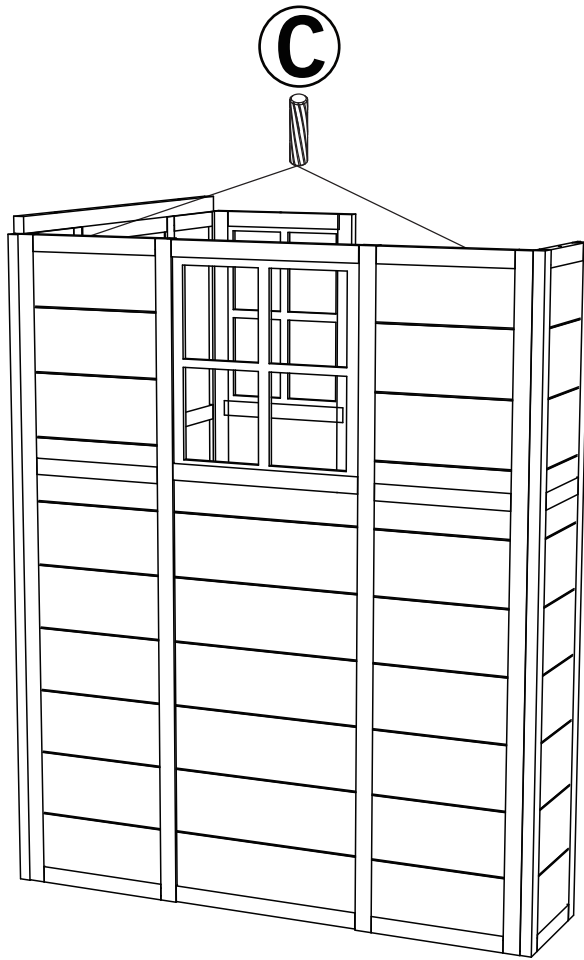

A x 4
M4x40

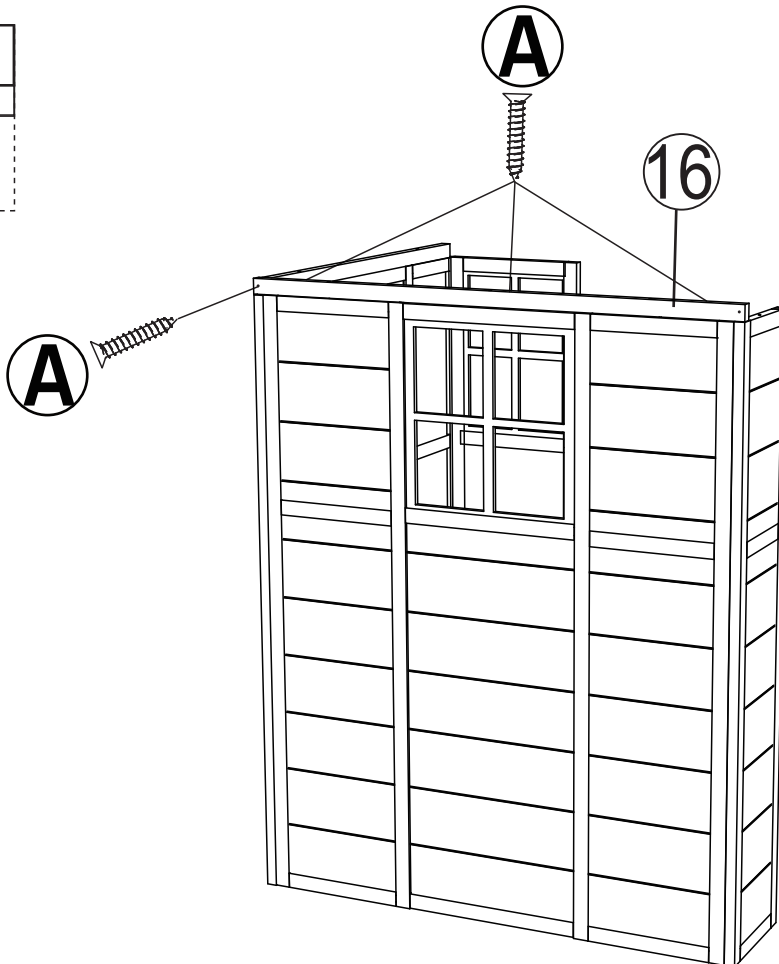
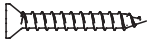

B x 5
M4x20

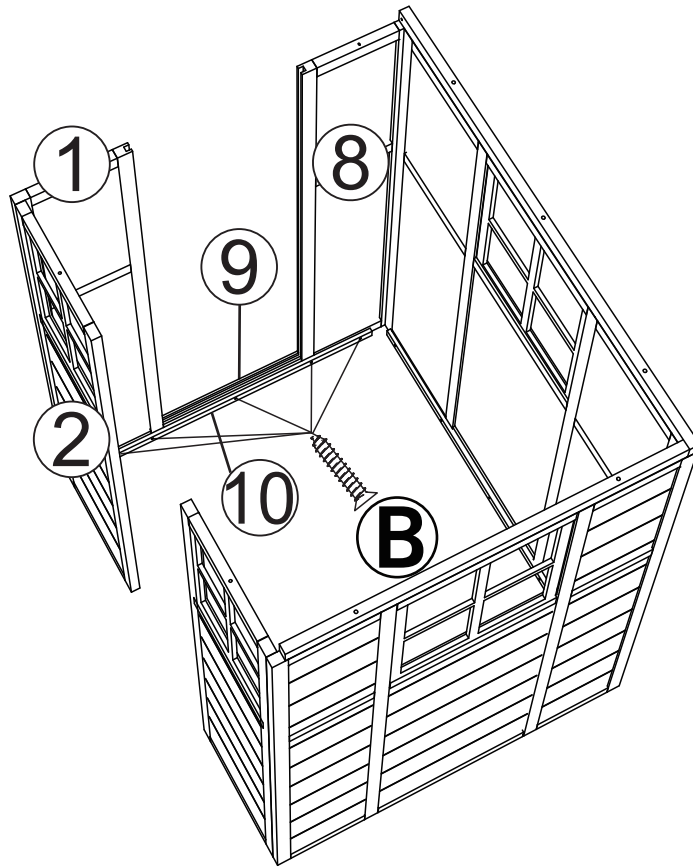

C x 2
M8x30

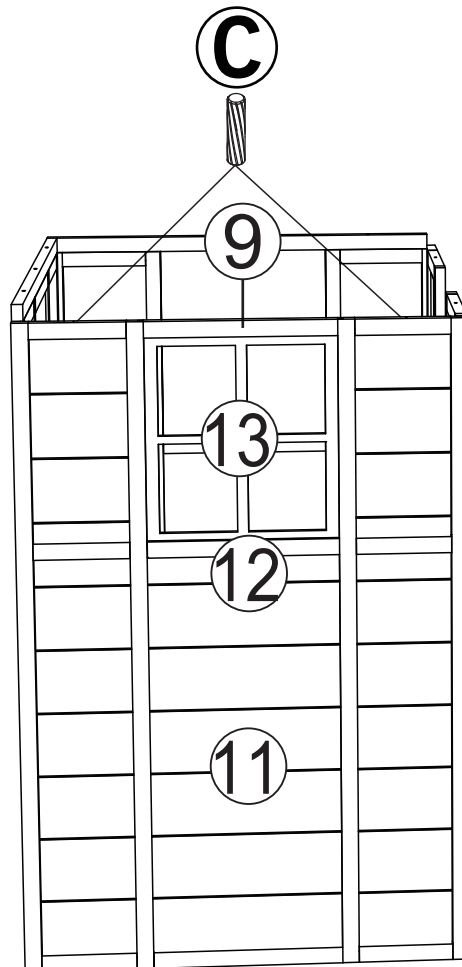

A x 4
M4x40

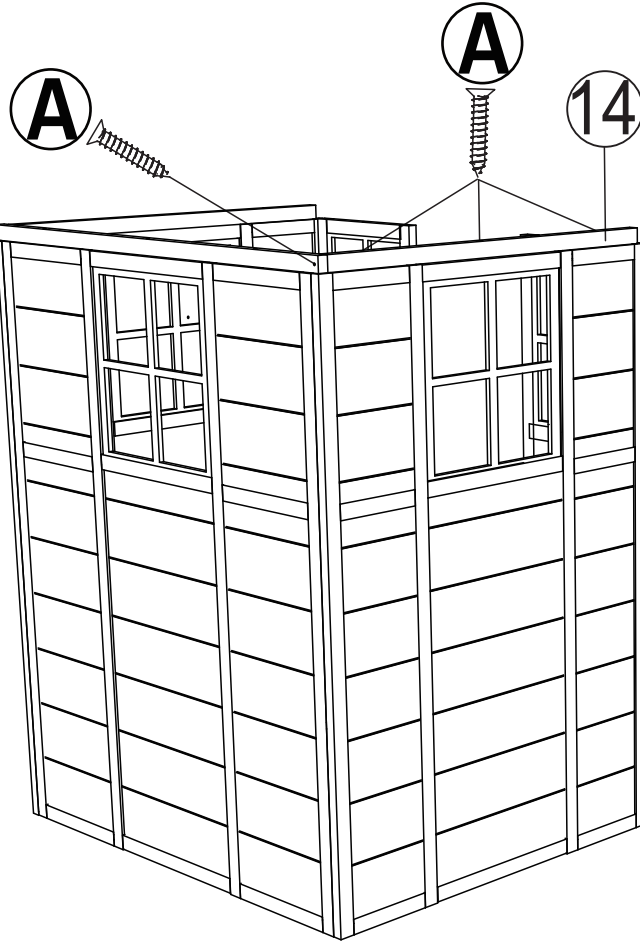

B x 4
M4x20

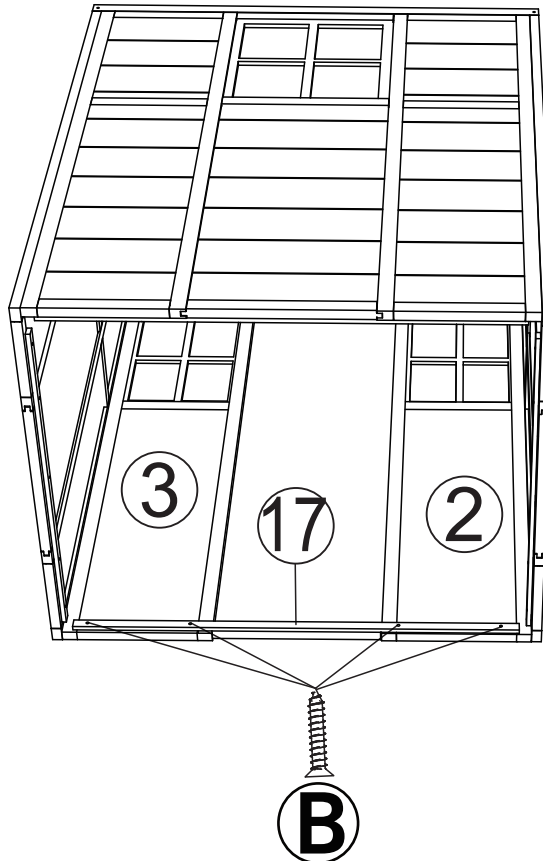
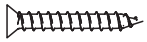

C x 2
M8x30

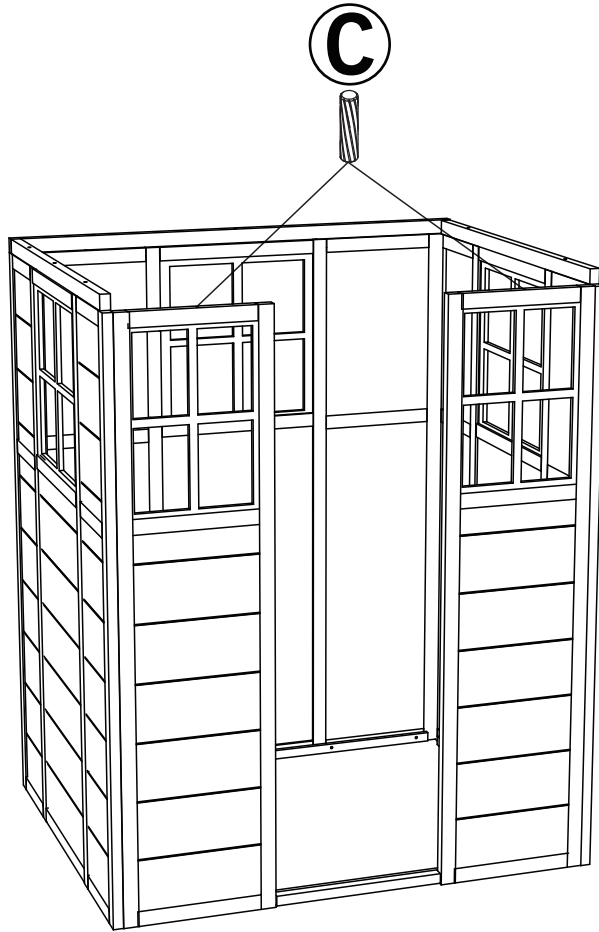

A x 4
M4x40

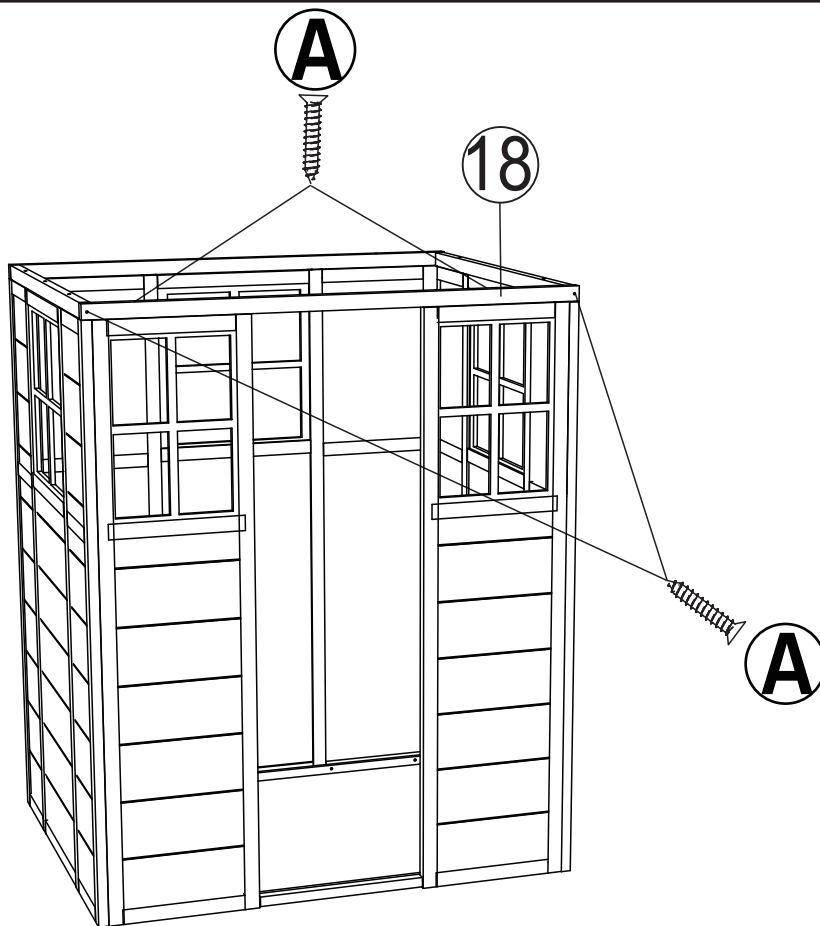

B x 8
M4x20

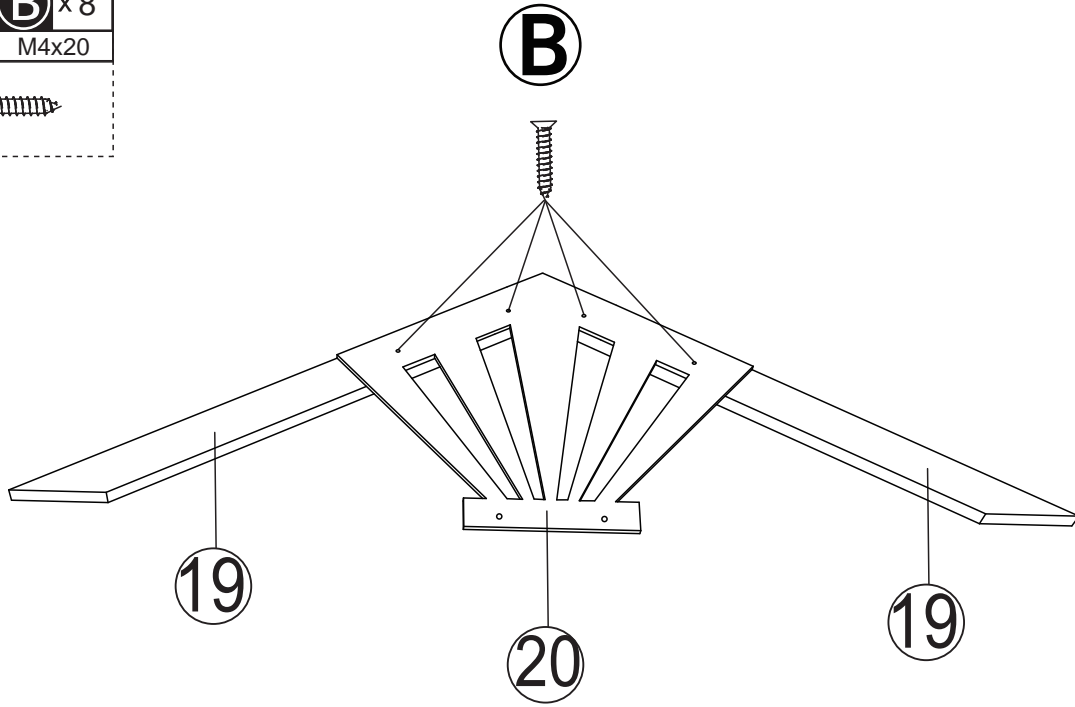
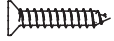

X2

A x 4
M4x40

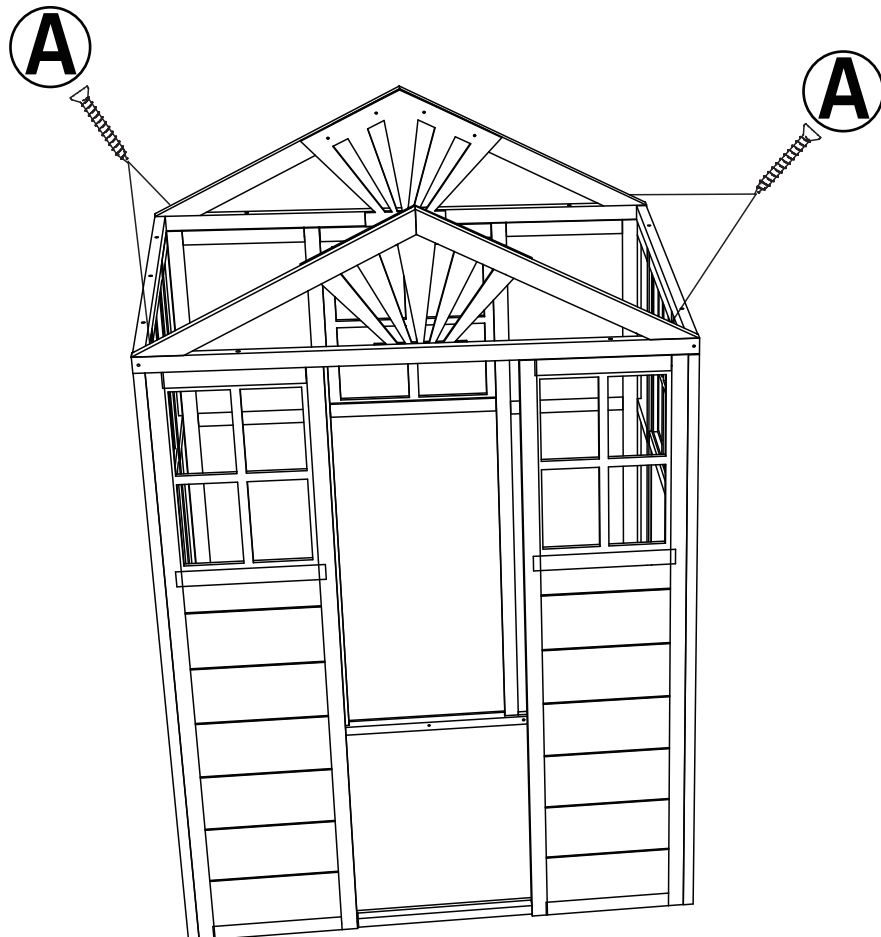

B x 4
M4x20

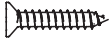

A x 4
M4x40

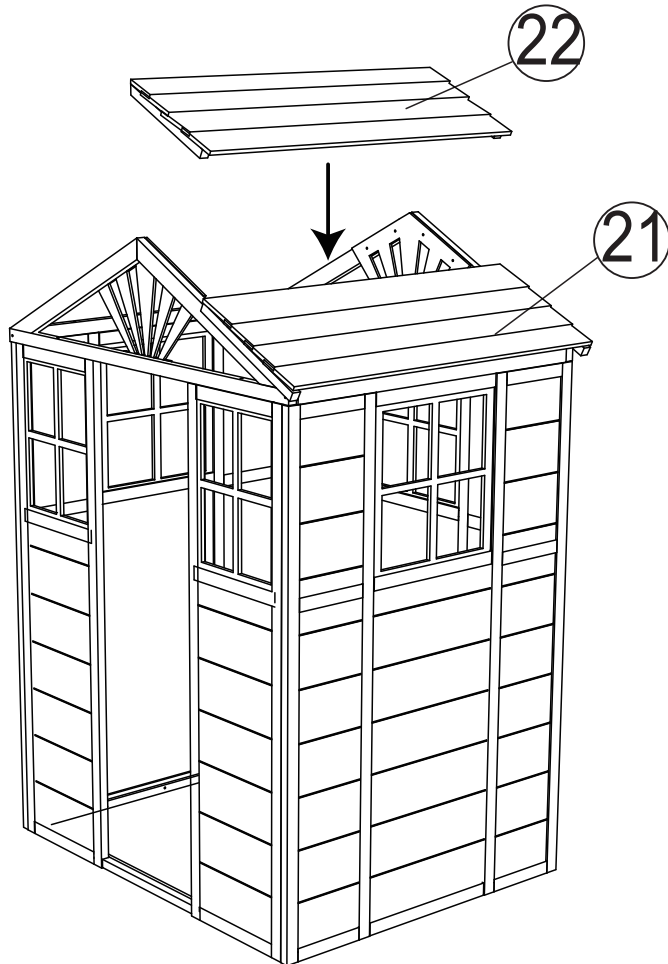
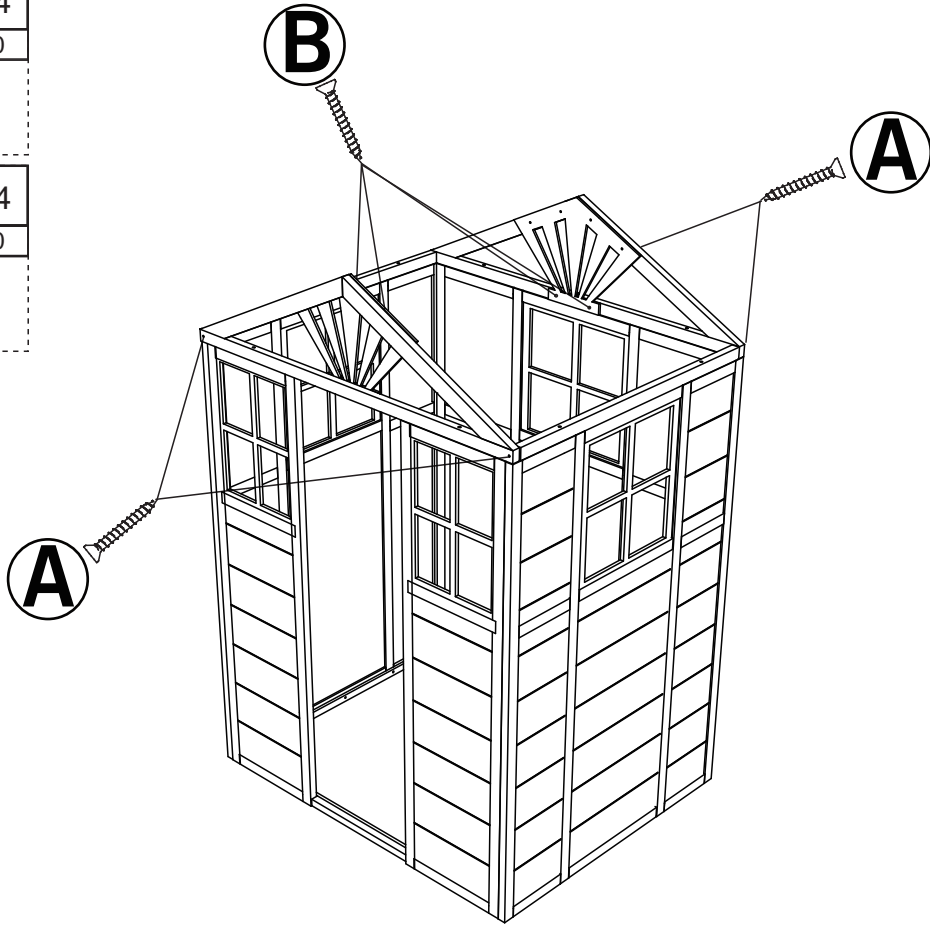

D x 4
M4x30

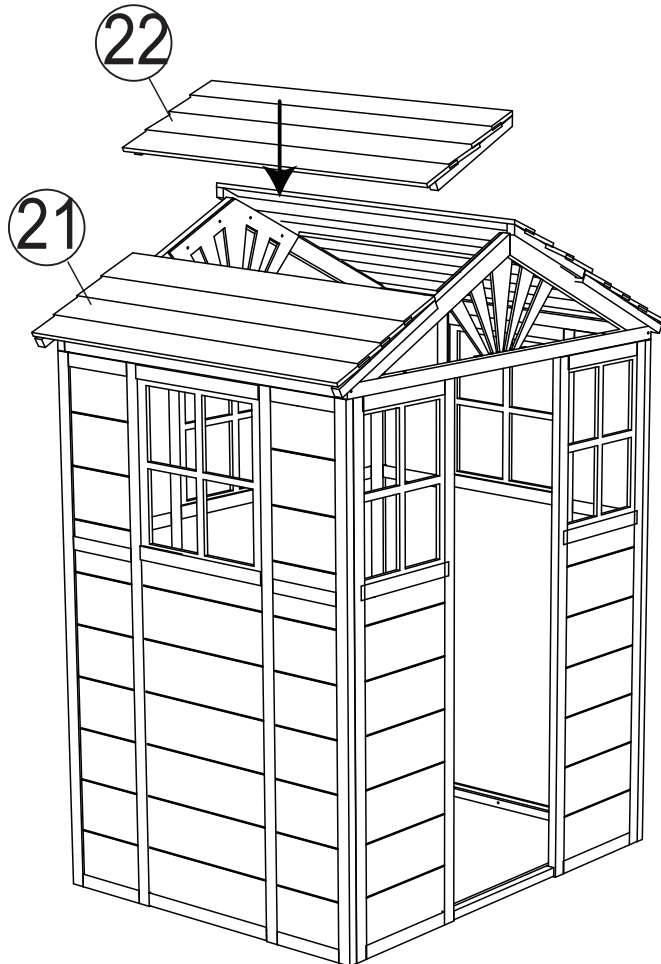
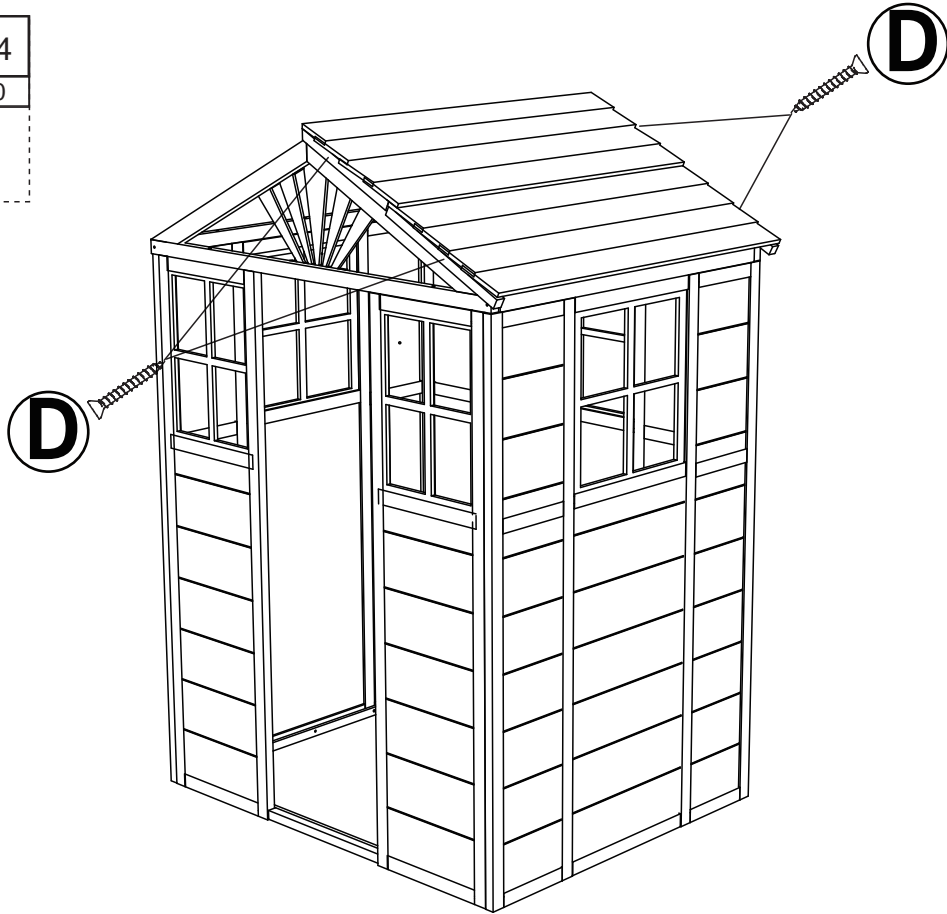

D x 4
M4x30

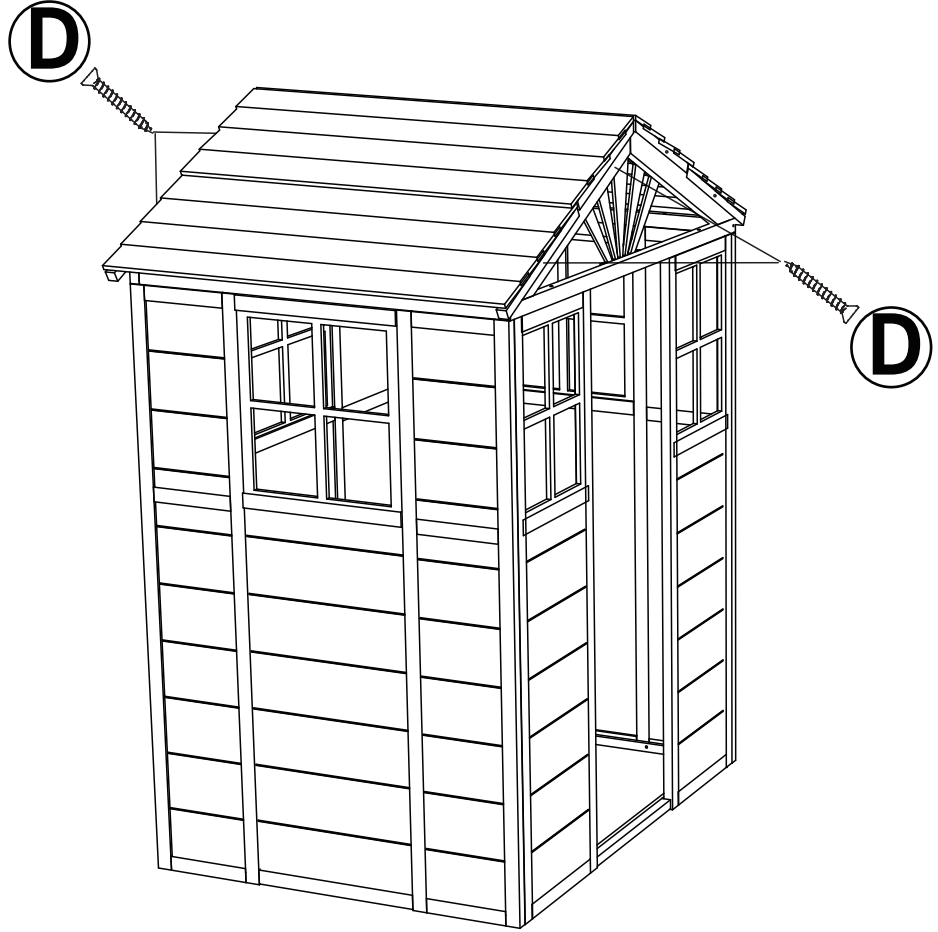

B x 4
M4x20

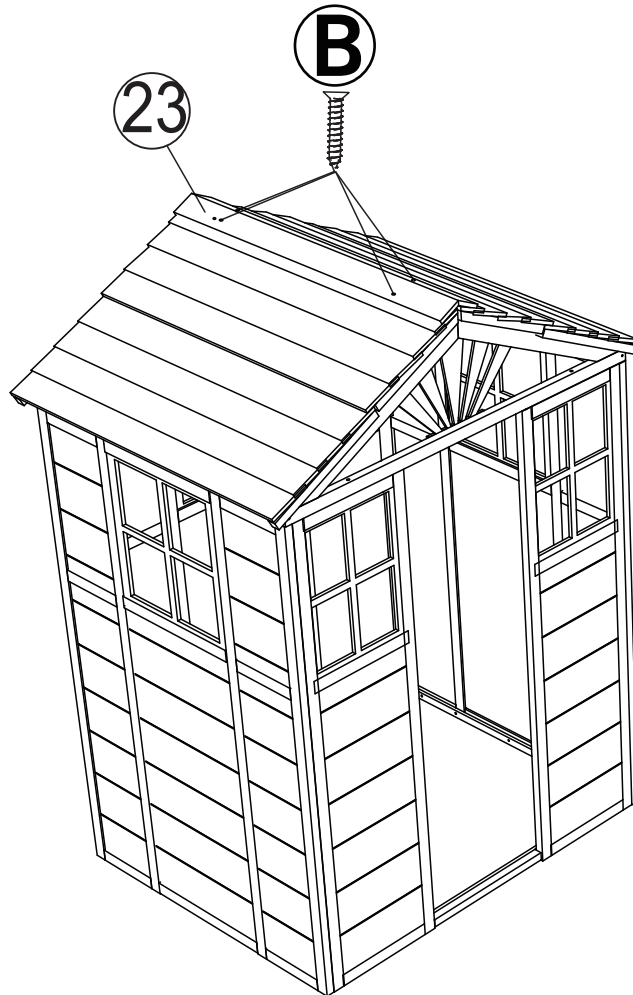
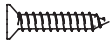

D x 4
M4x30

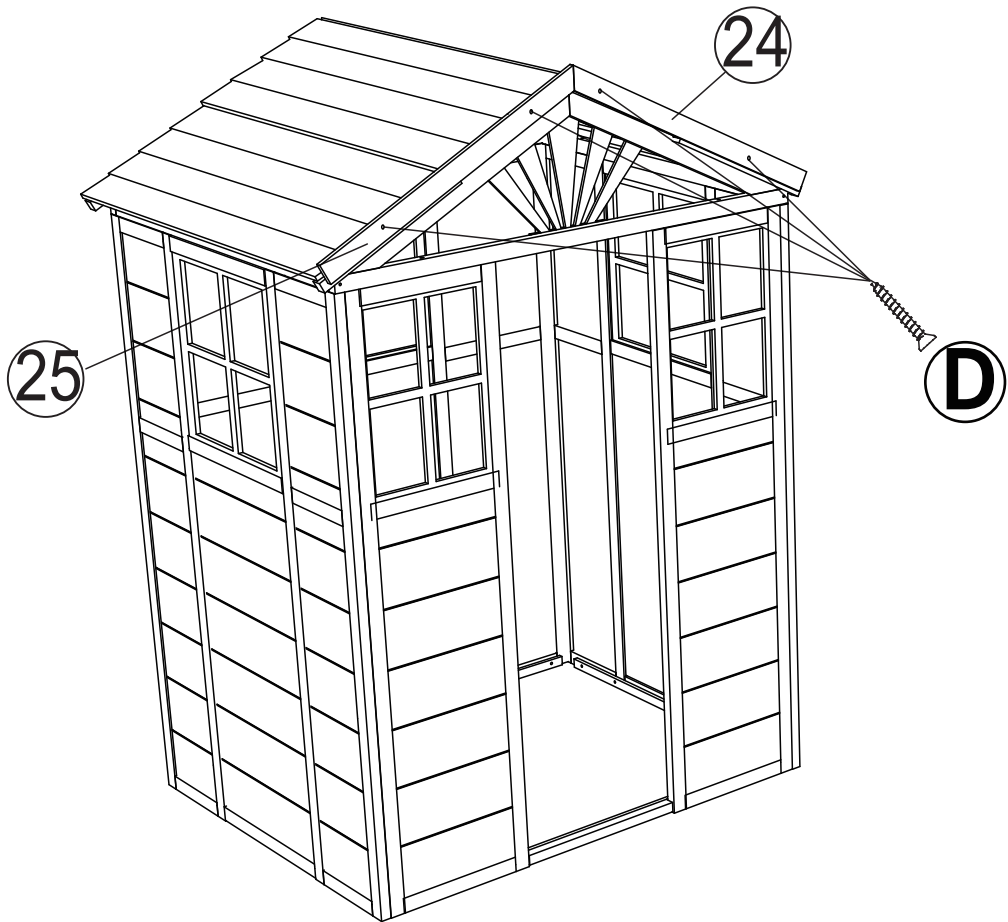

D x 4
M4x30

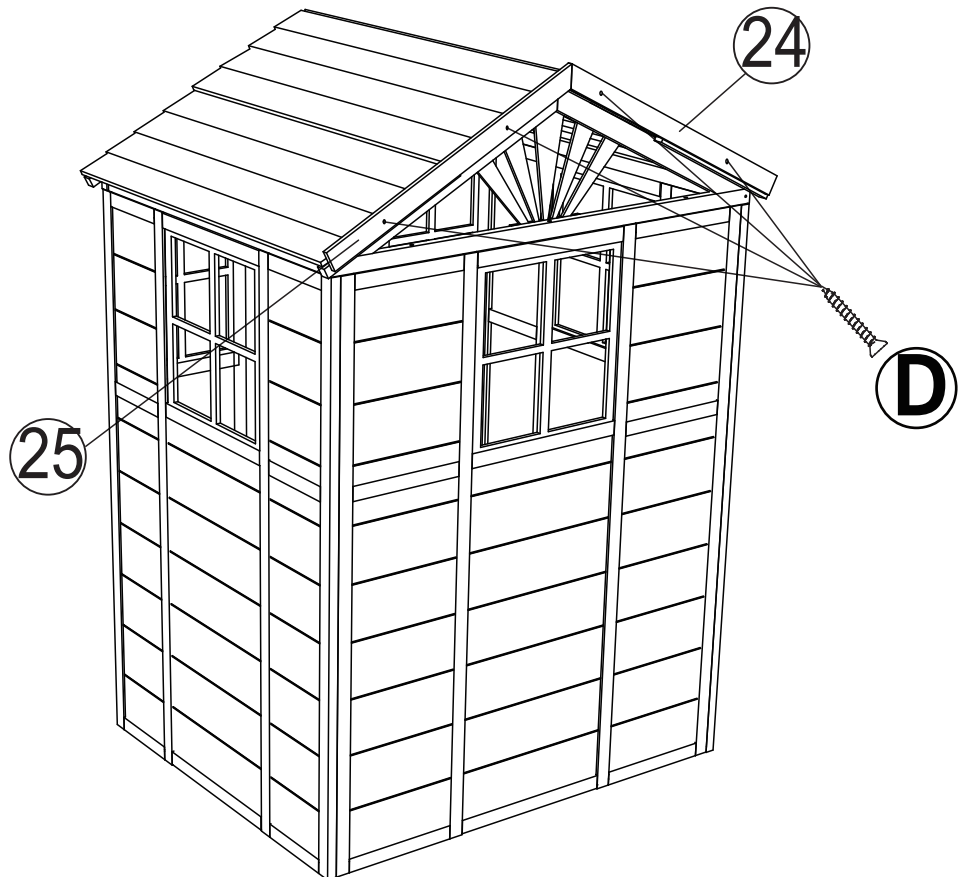

E x8
M3x10



V x1



V

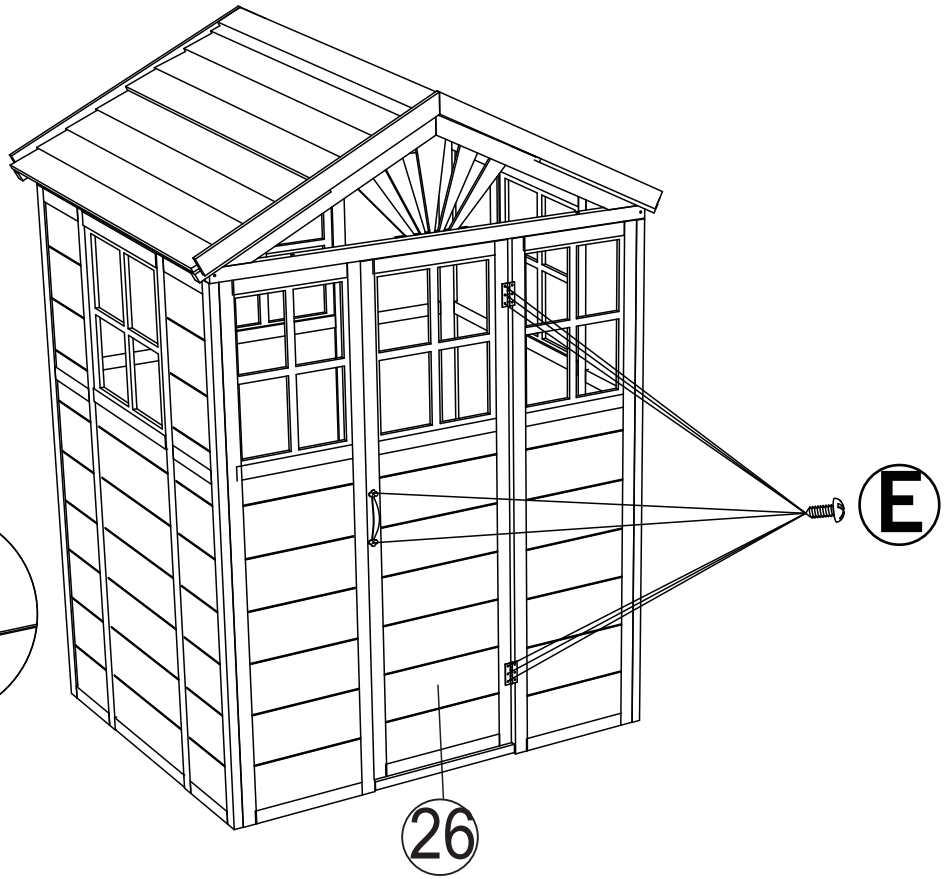
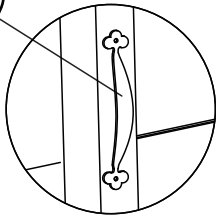

F x 4
M6X60



G x 8



H x 4
M6X50

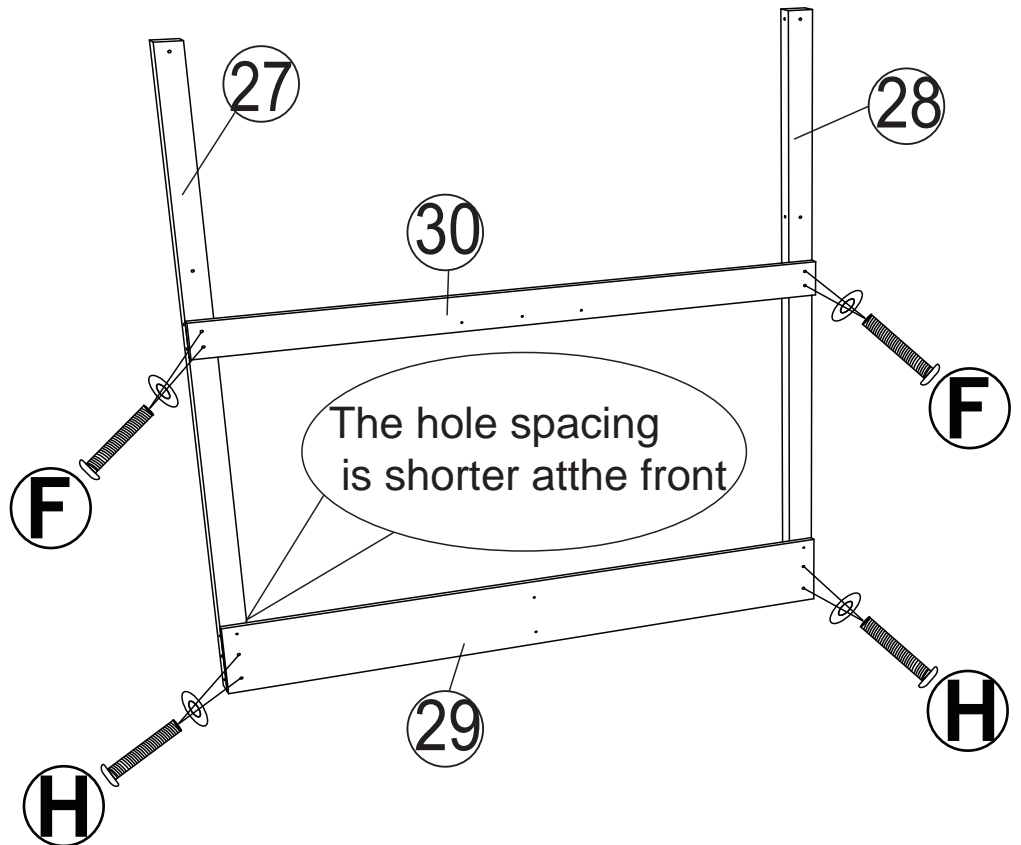

A x 2
M4x40

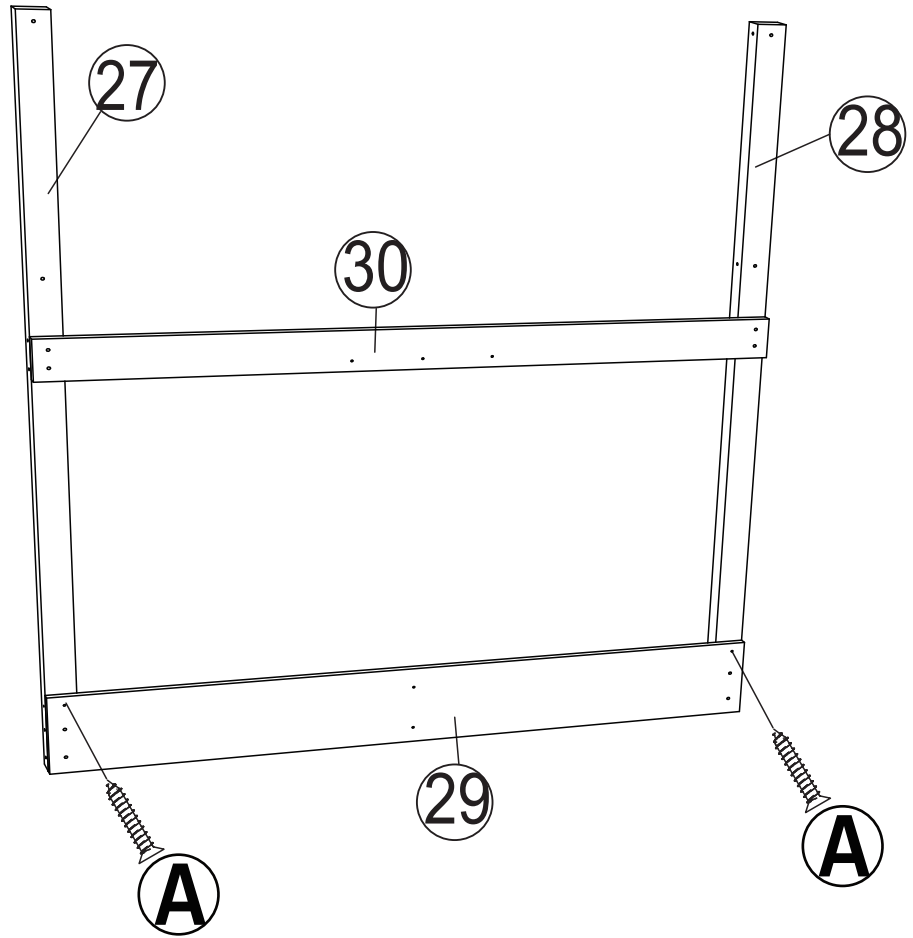
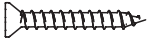

A x 5
M4x40

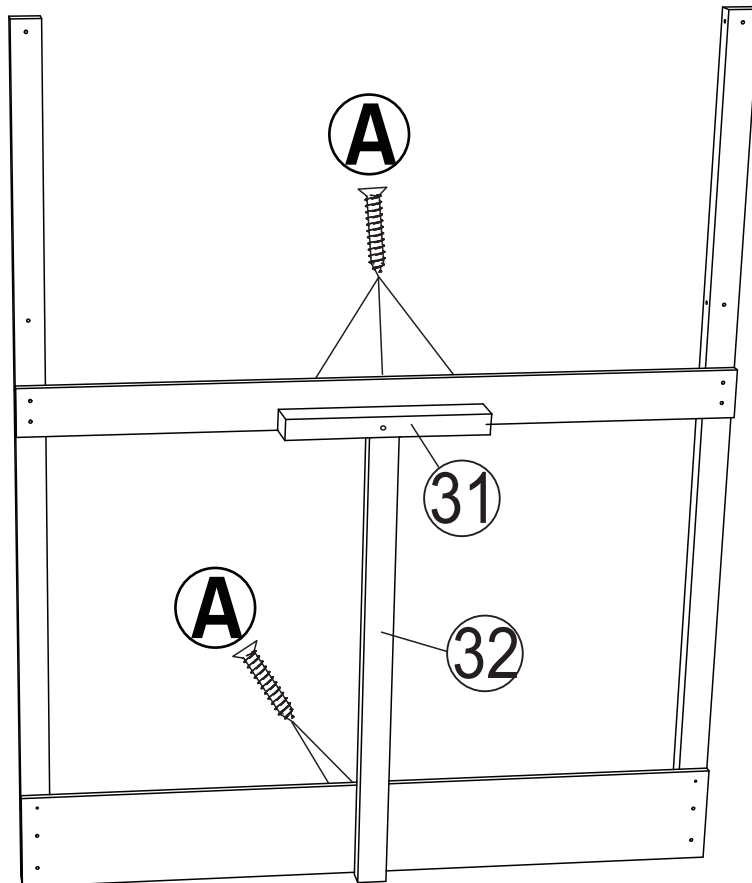

I x 1
M4x60

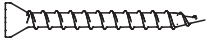

External alignmen

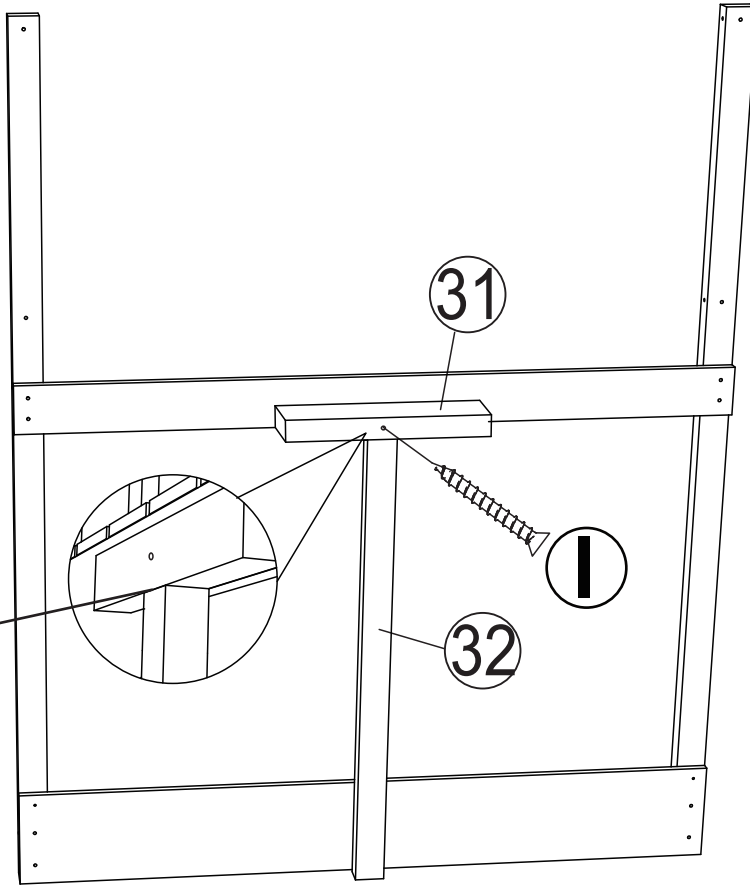

J x 8
M6X70



G x 8



The hole spacing
is shorter at the front

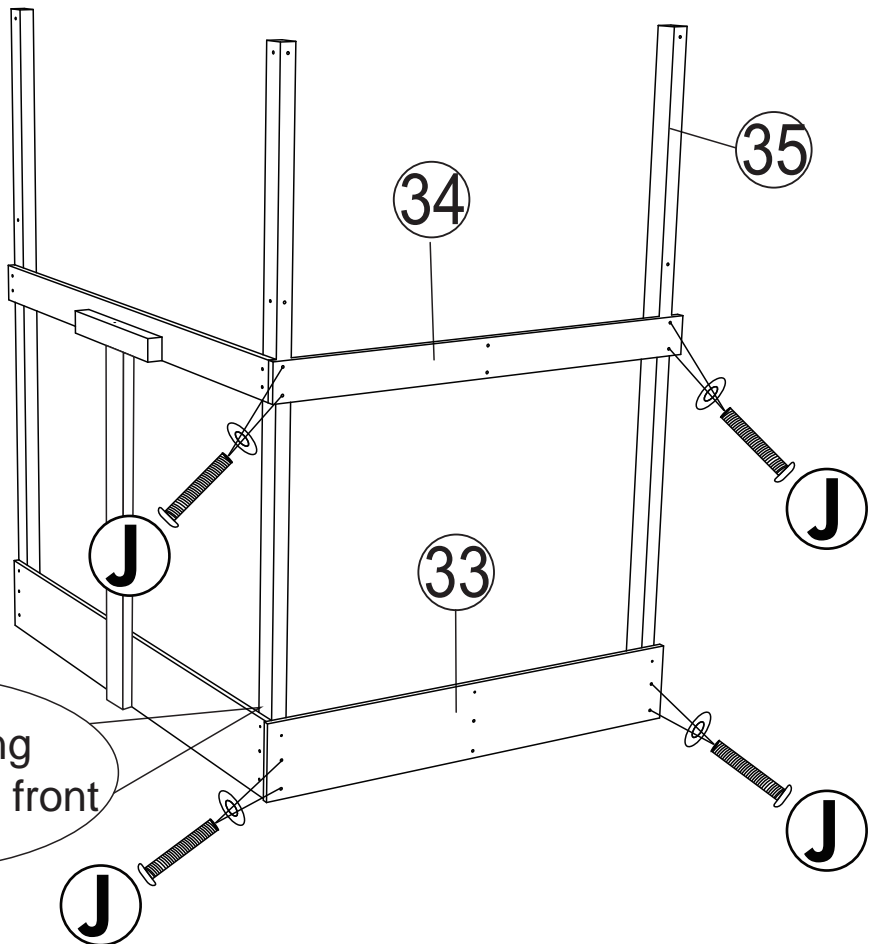

A x 2
M4x40

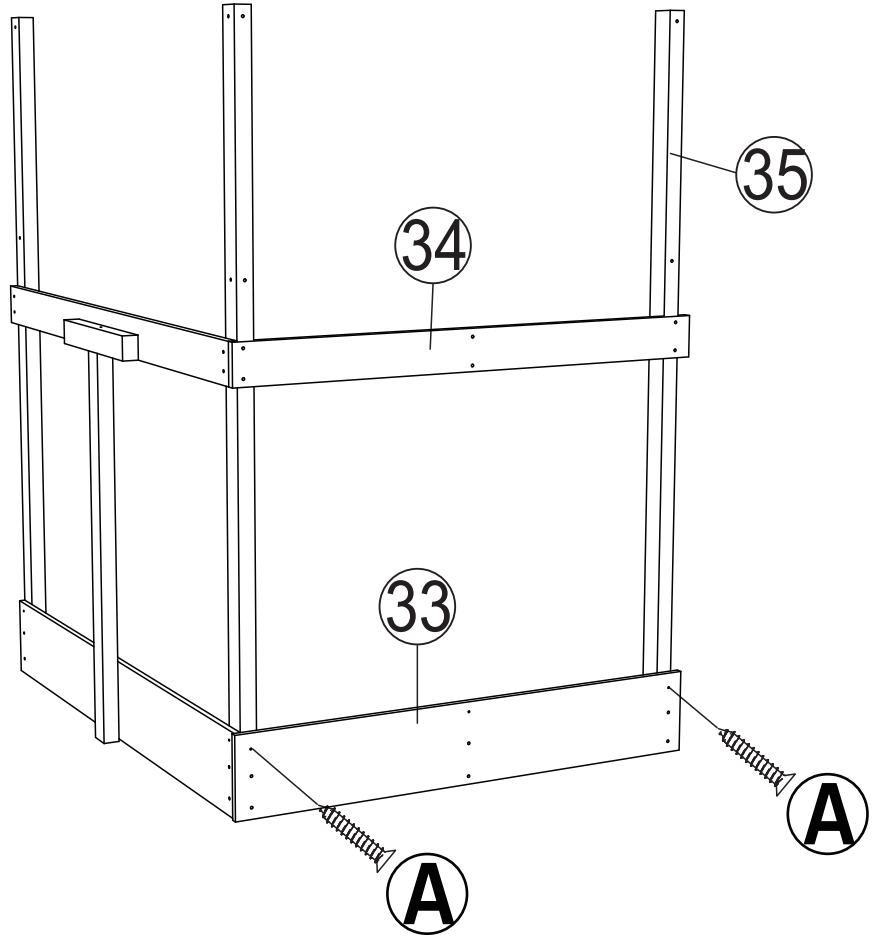
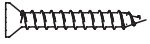

F x 2
M6x60



G x 4



H x 2
M6x50

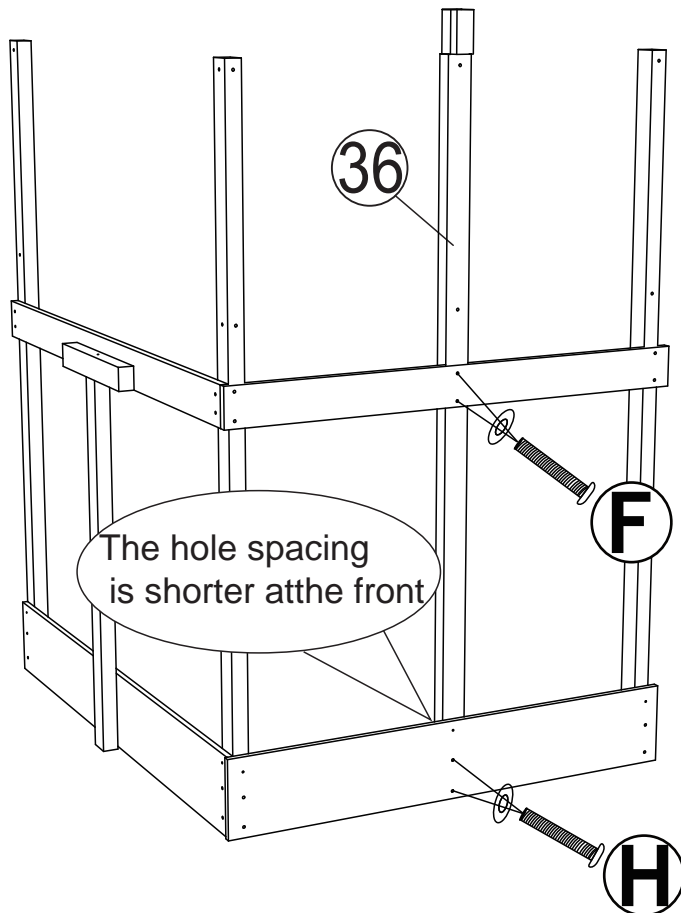

A x 1
M4x40

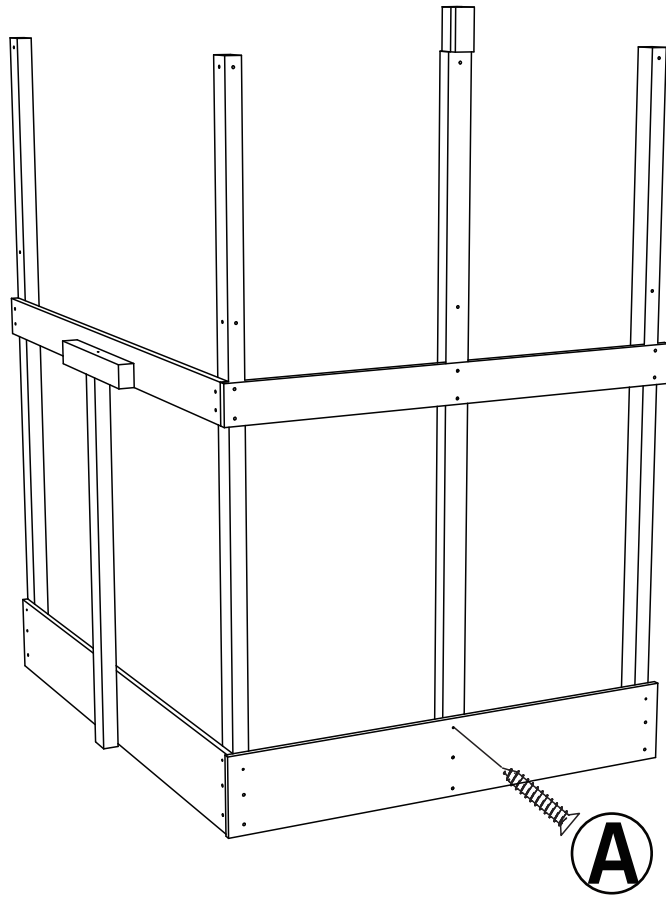

F x 4
M6X60



G x 8



H x 4
M6X50

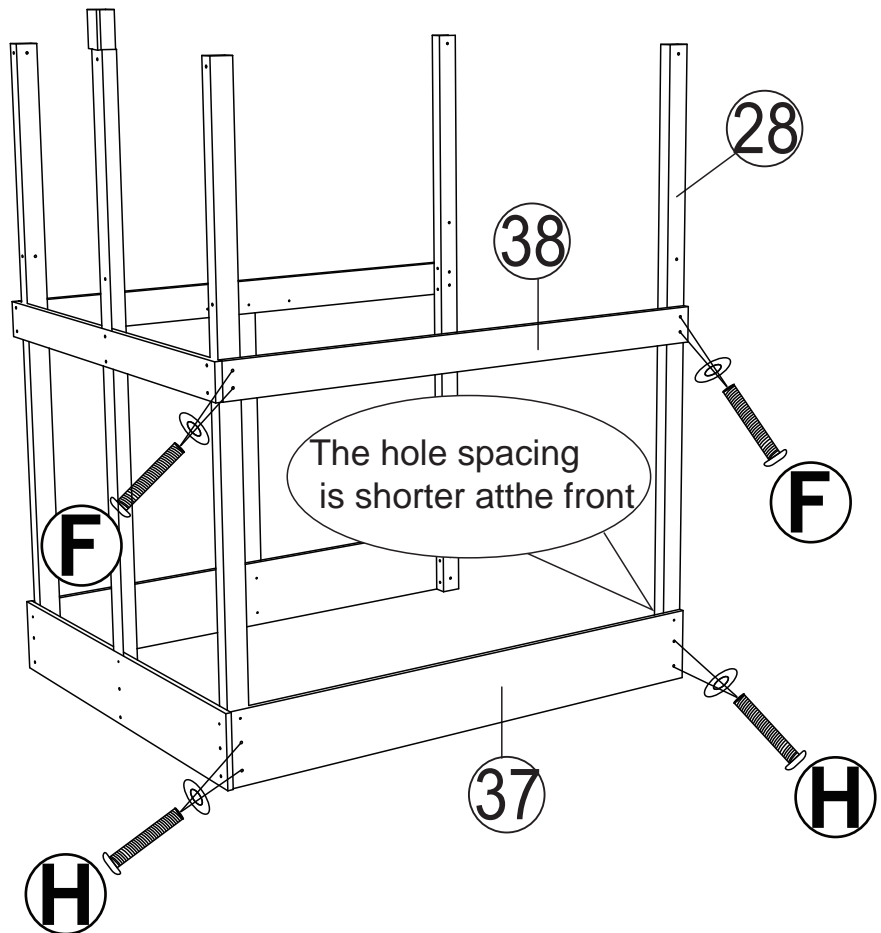

A x 2
M4x40

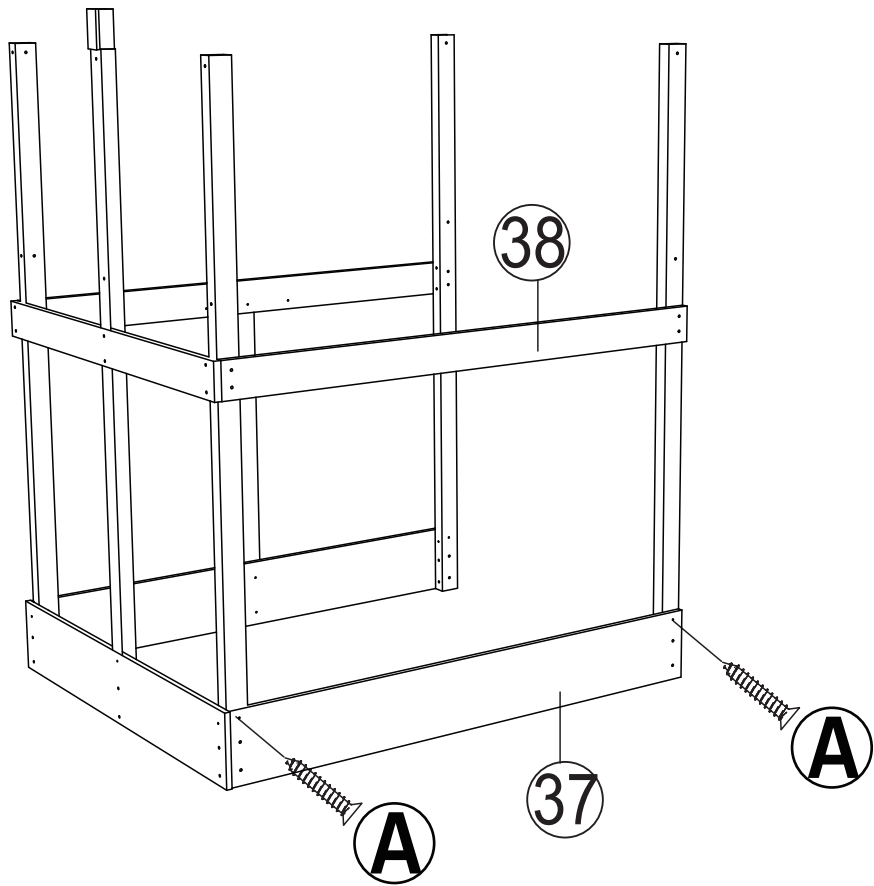

J x 8
M6x70



G x 8

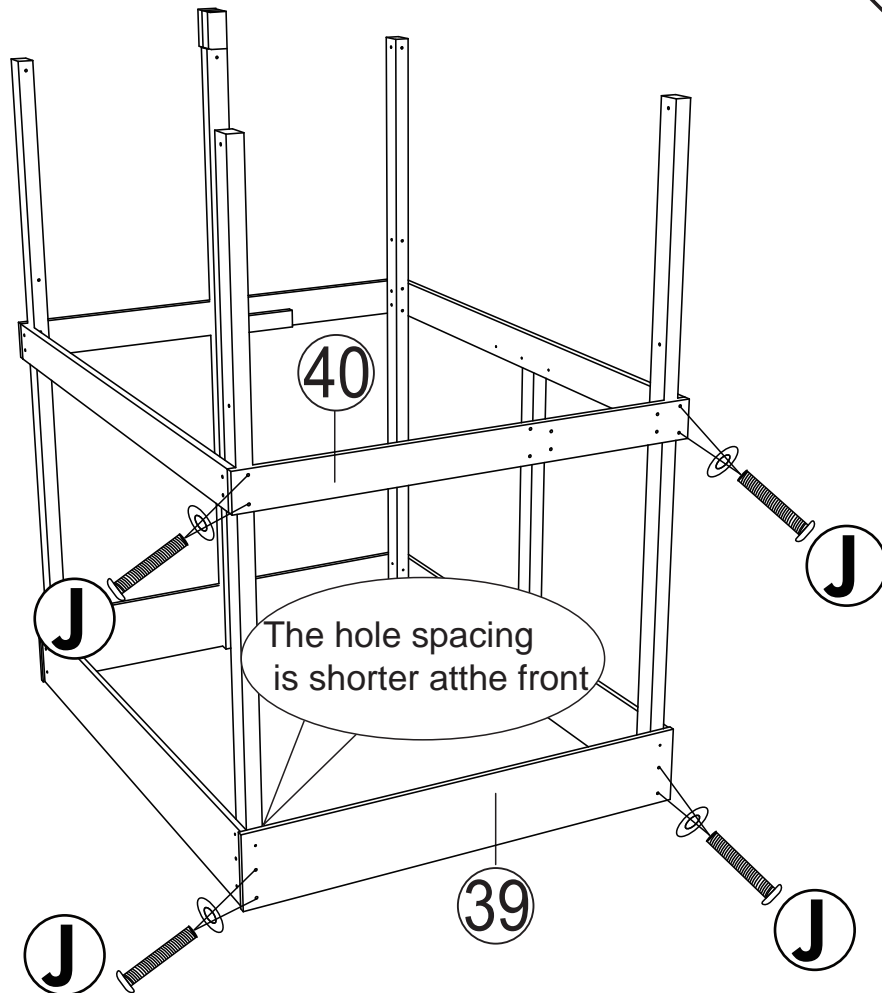

A x 2
M4x40

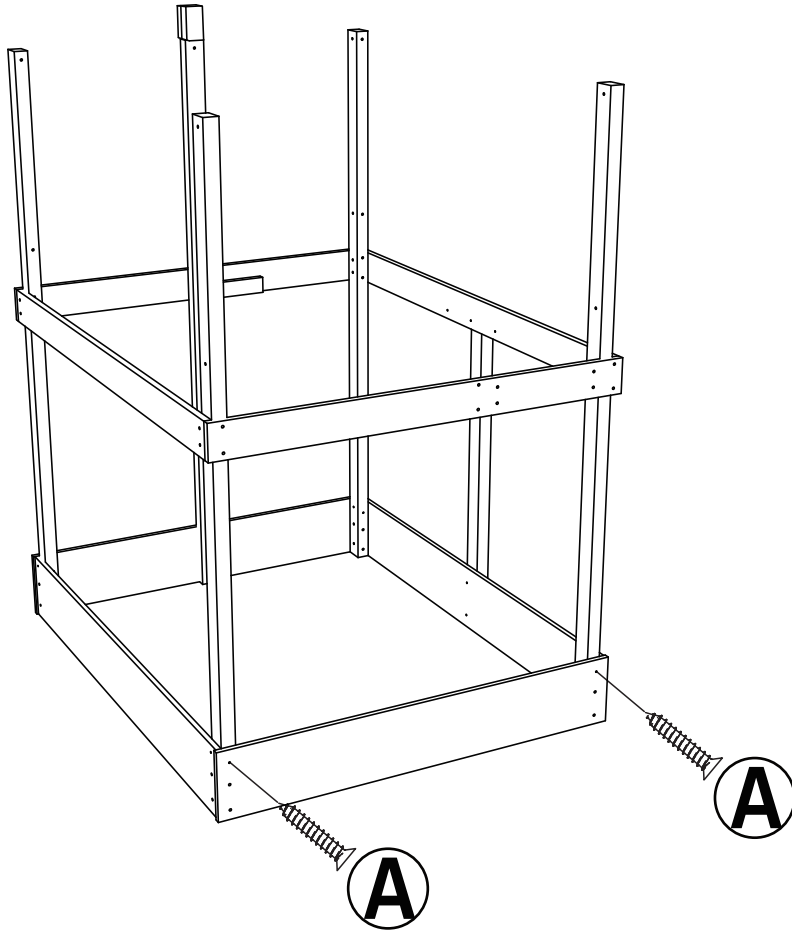

K x 4
M4x35



S x 4
M4x50

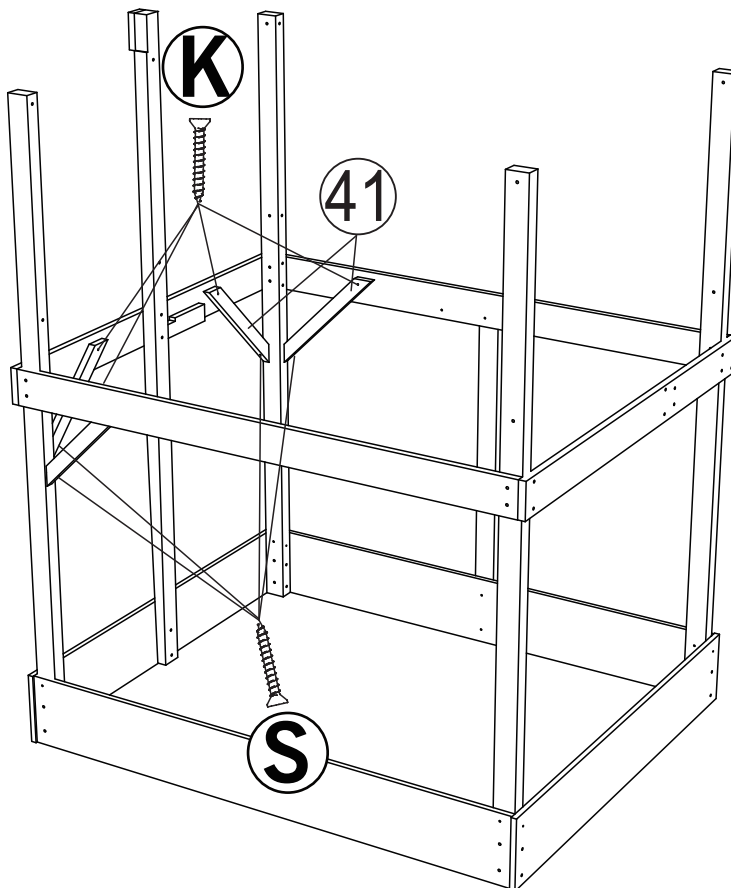

K x 4
M4x35

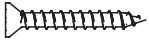

S x 4
M4x50

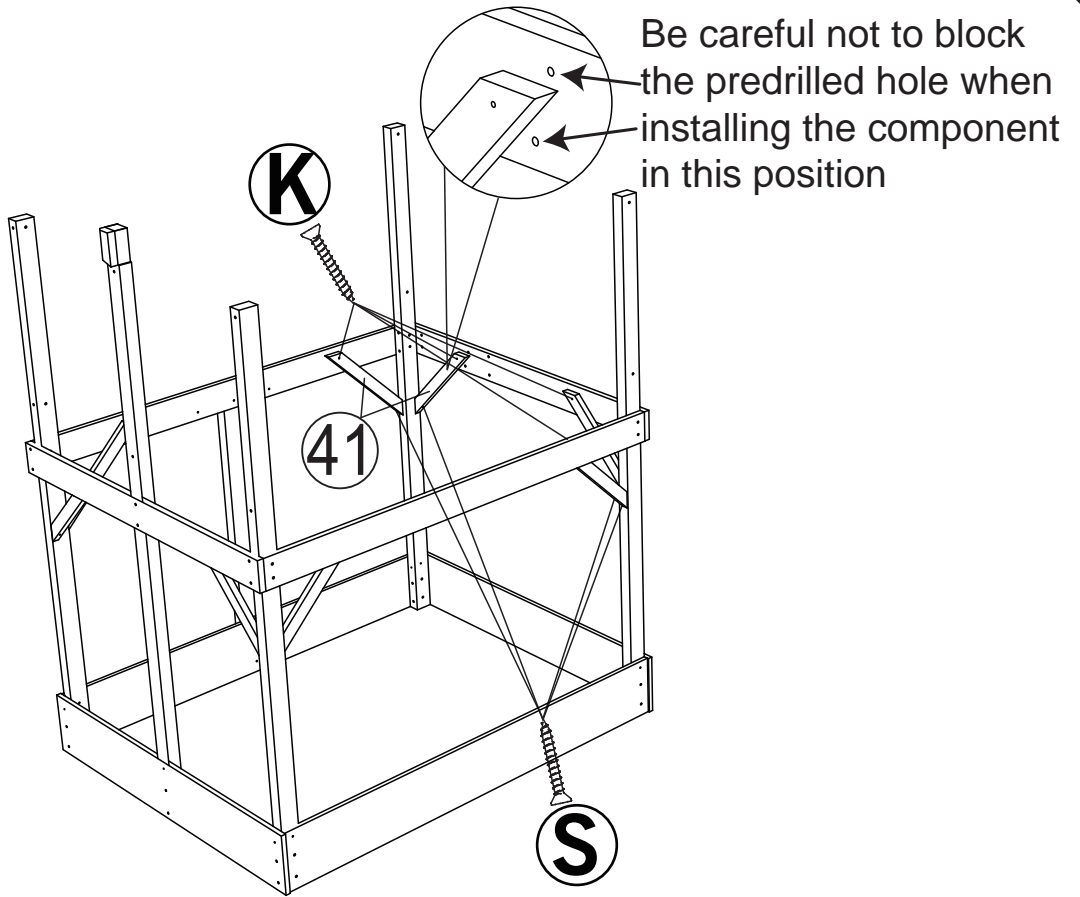

D x16
M4x30

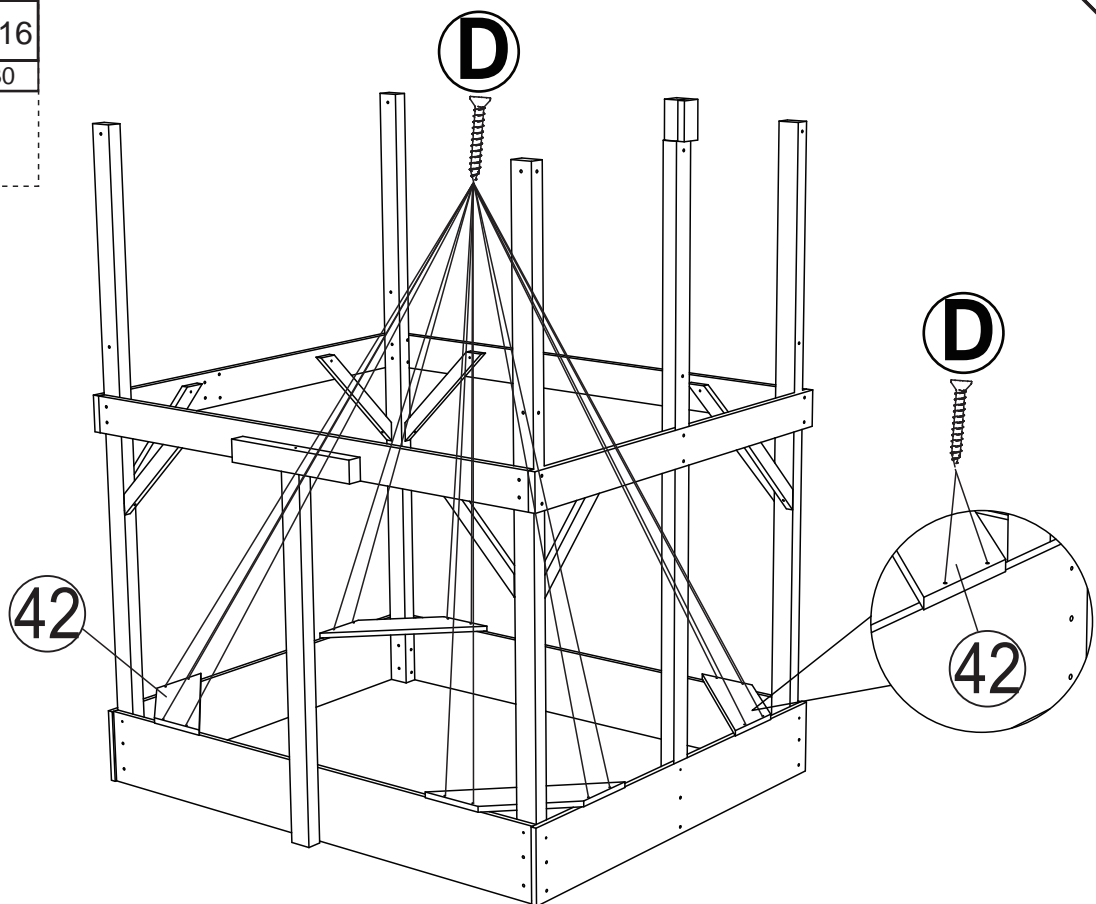

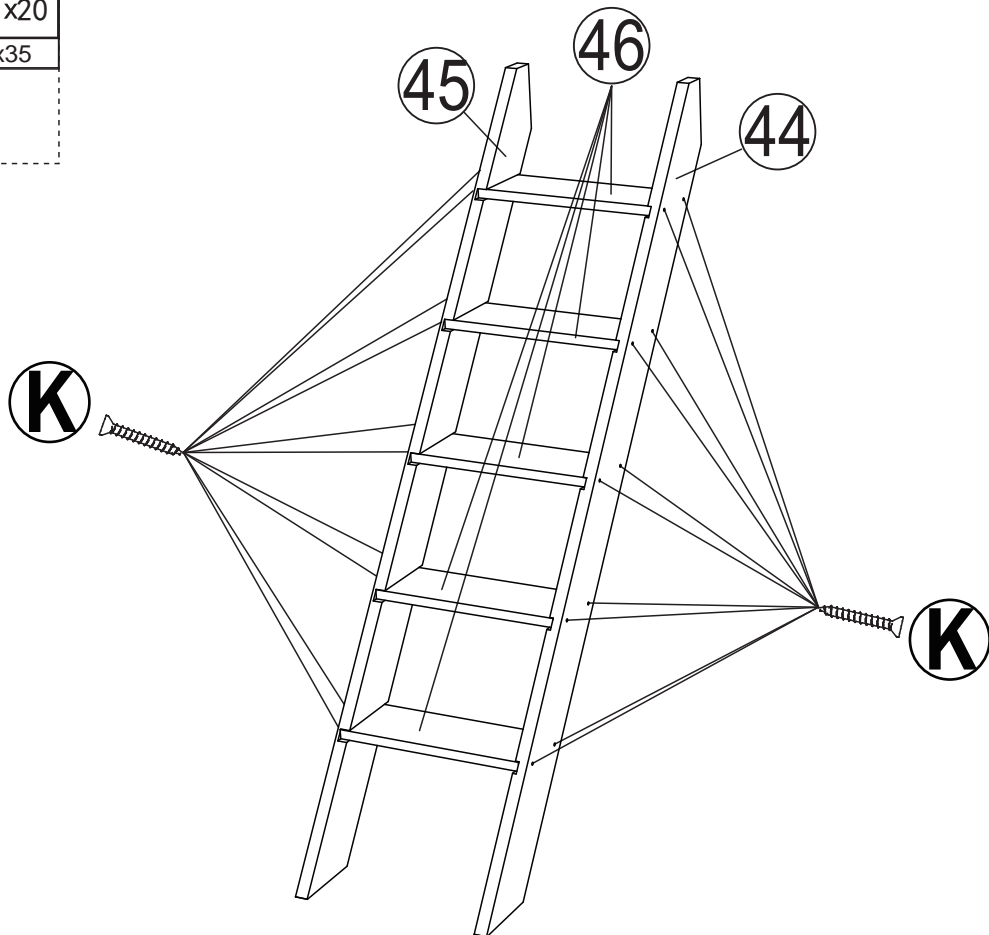
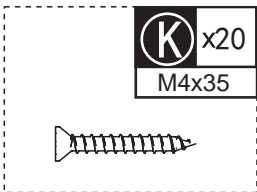
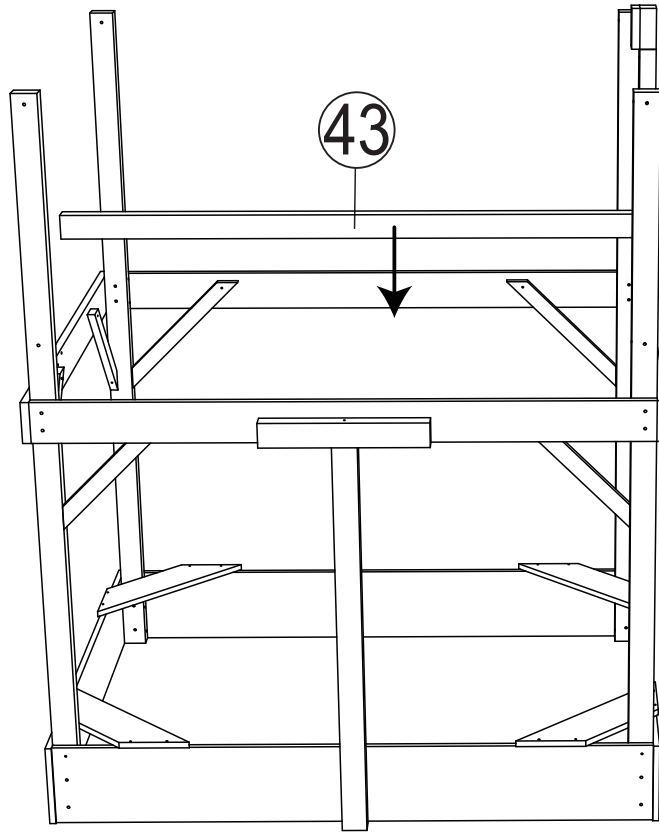

S x 2
M4x50

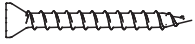

S

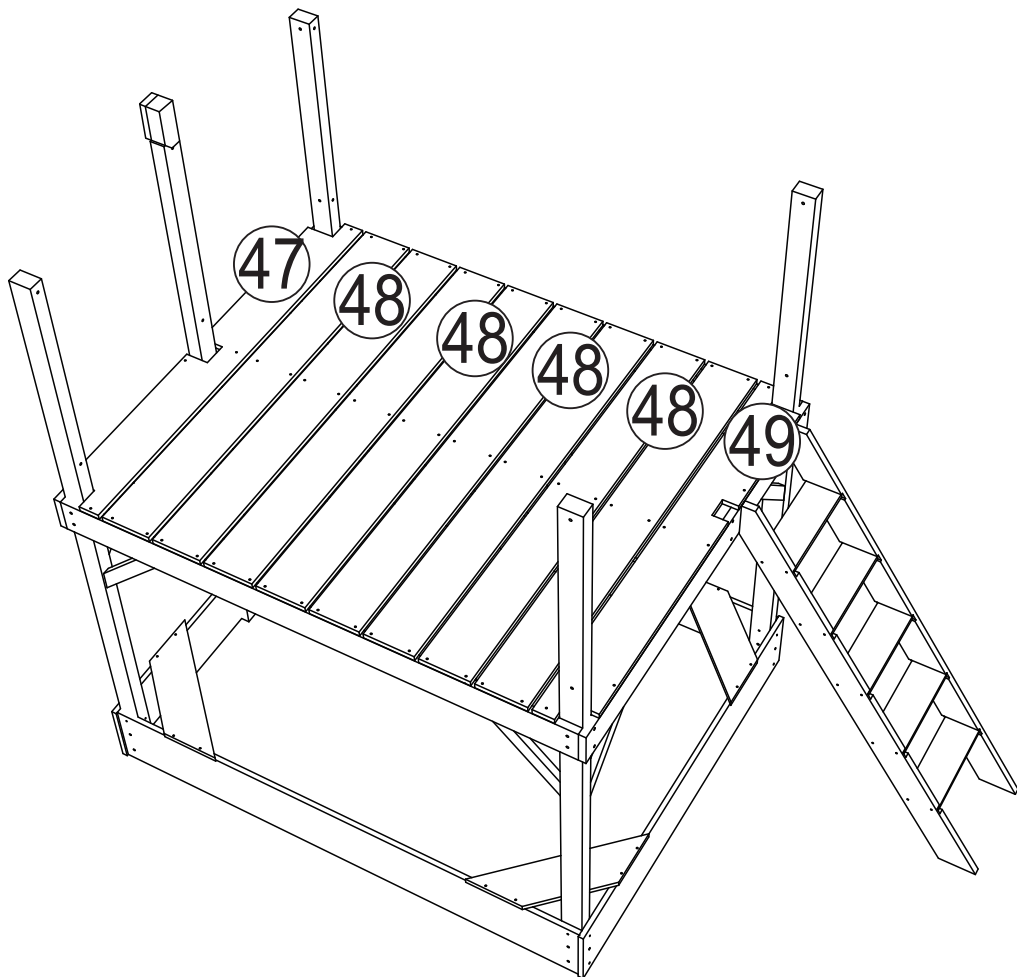
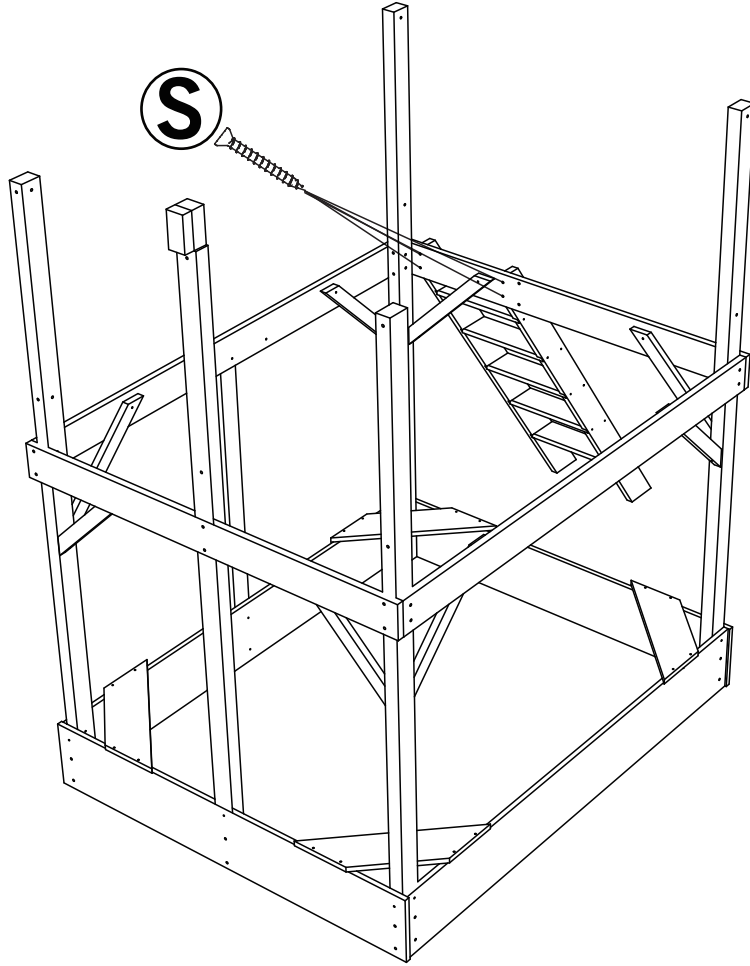

D x62
M4x30

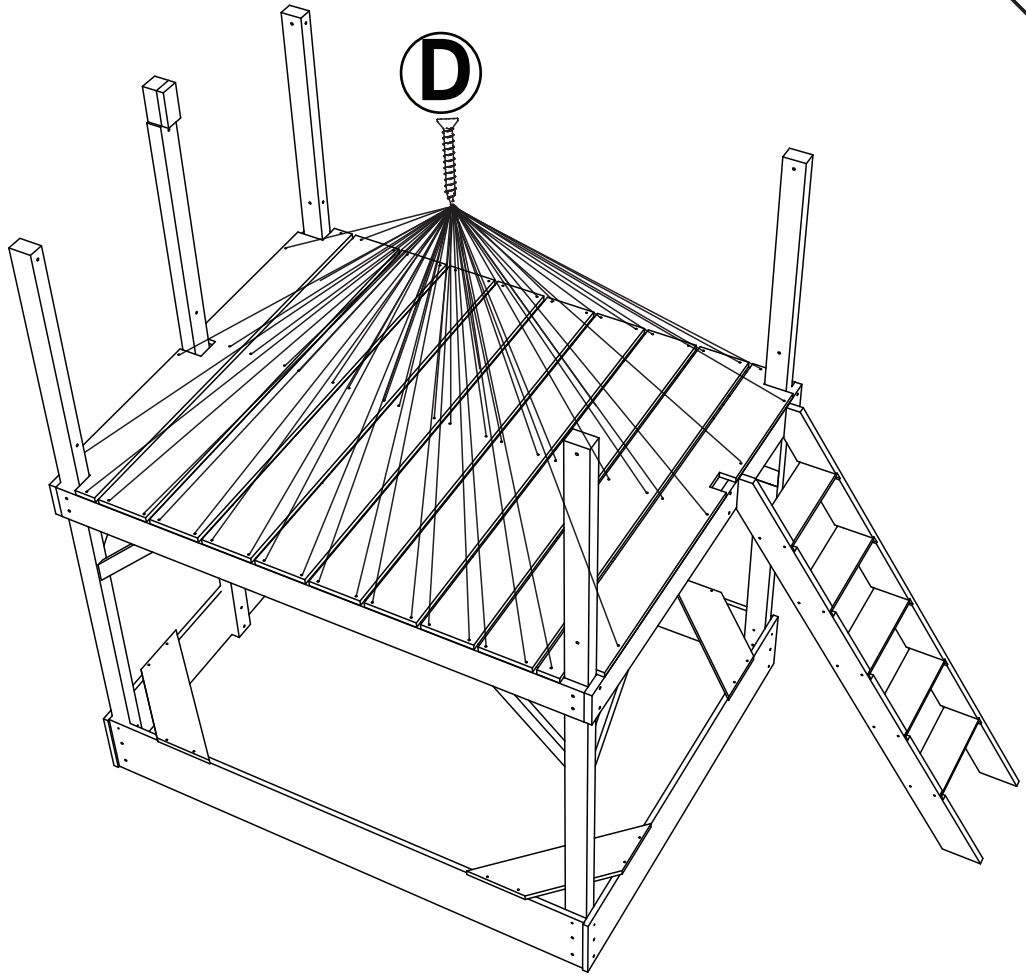

F x 2
M6x60



G x 2

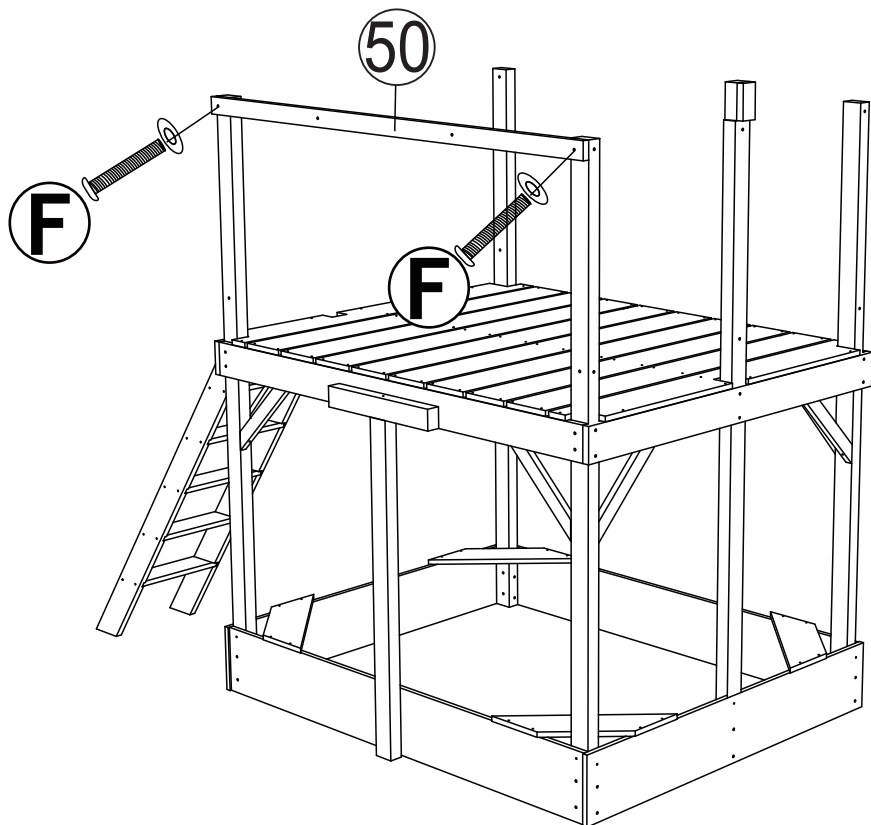

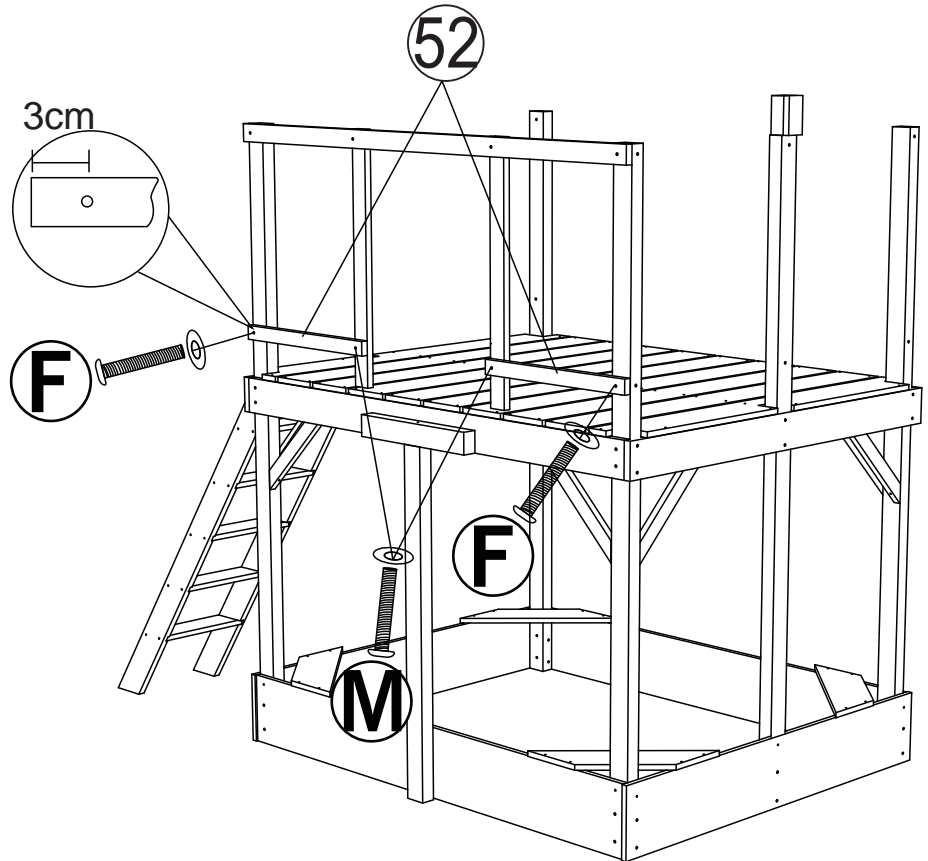
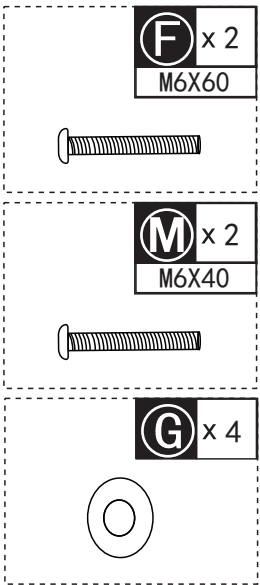
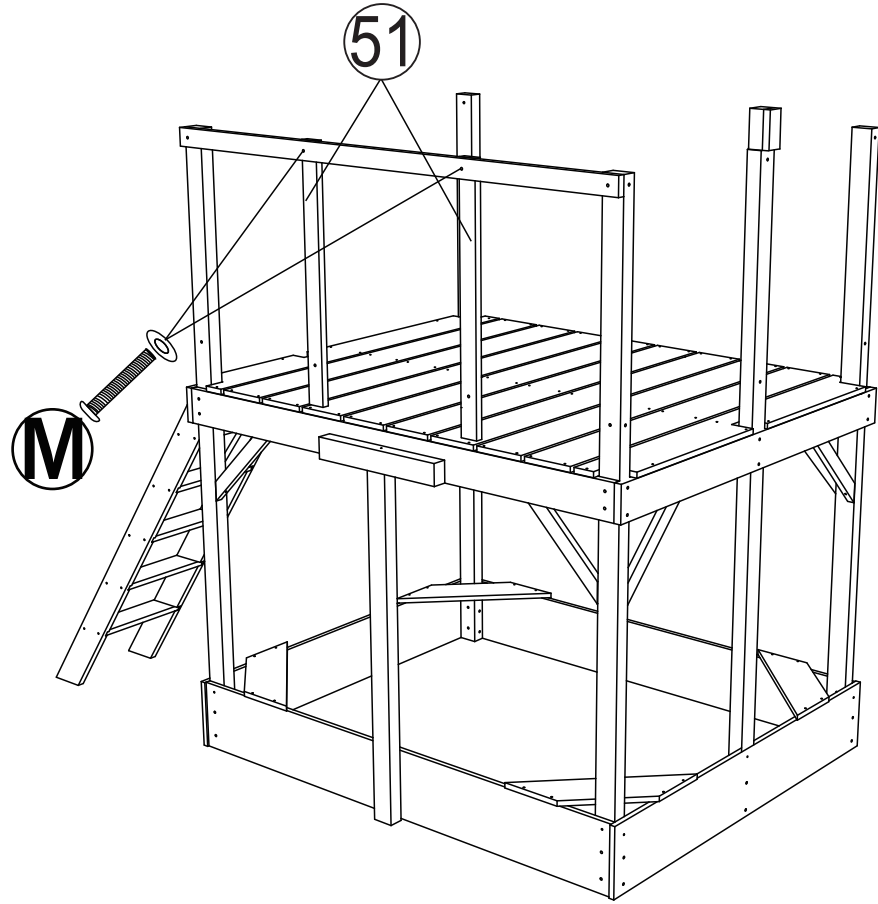
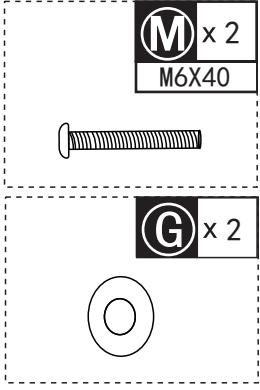

F x 1
M6X60



M x 2
M6X40



G x 3

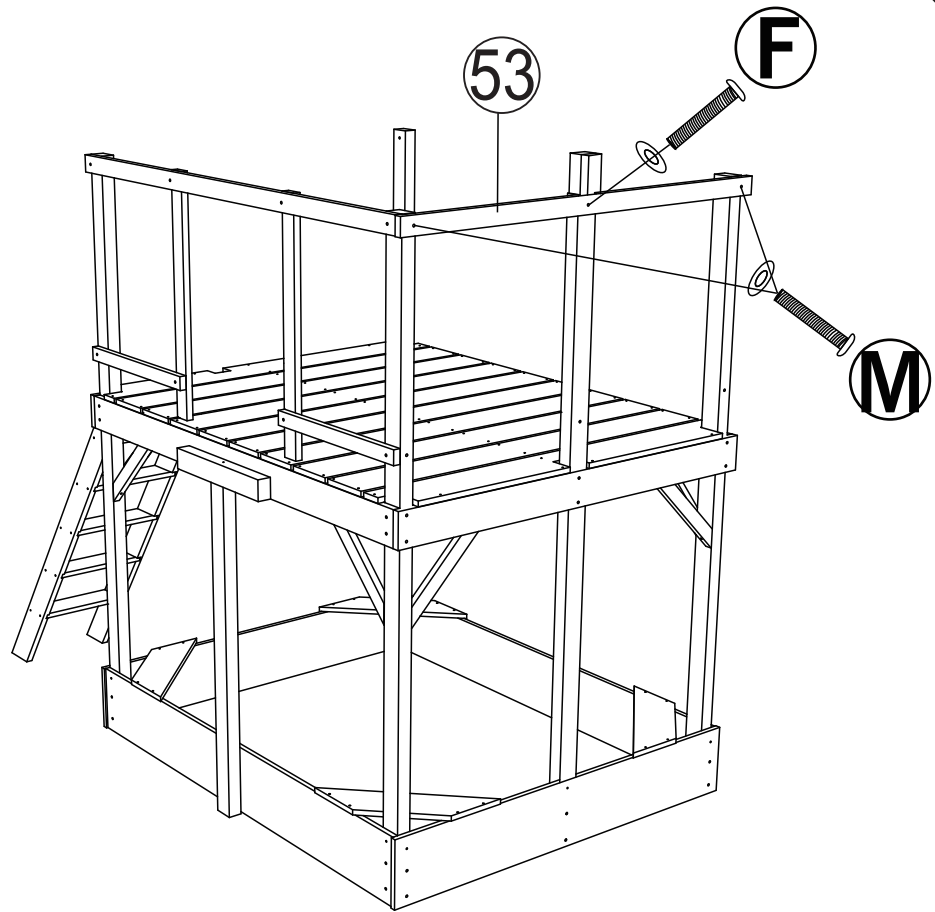

F x 1
M6X60



M x 2
M6X40



G x 3

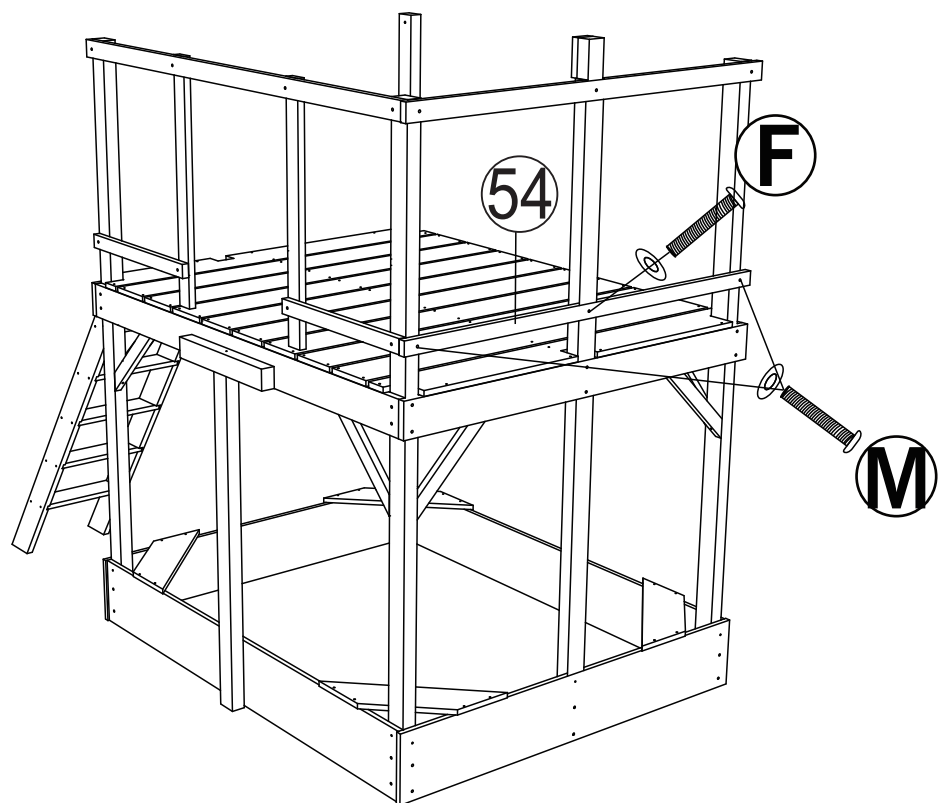

F x 2
M6X60

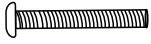

M x 2
M6X40

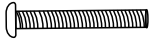

G x 4

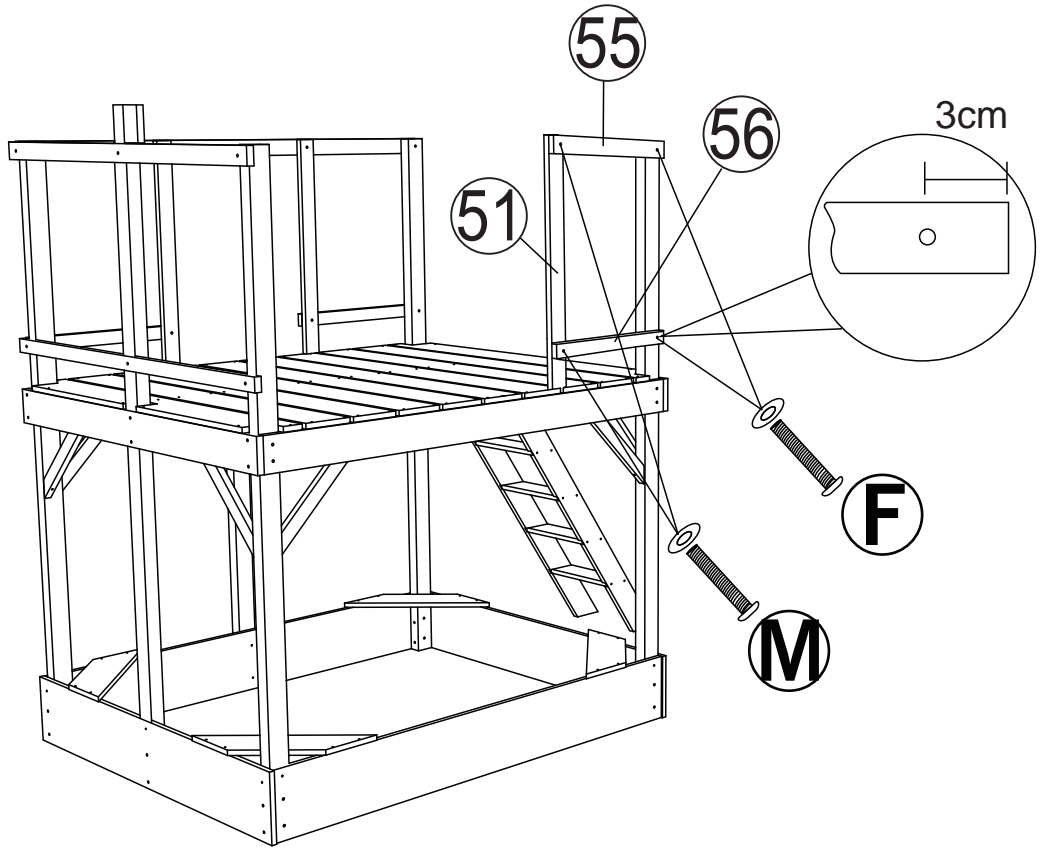

M x 2
M6X40



G x 2

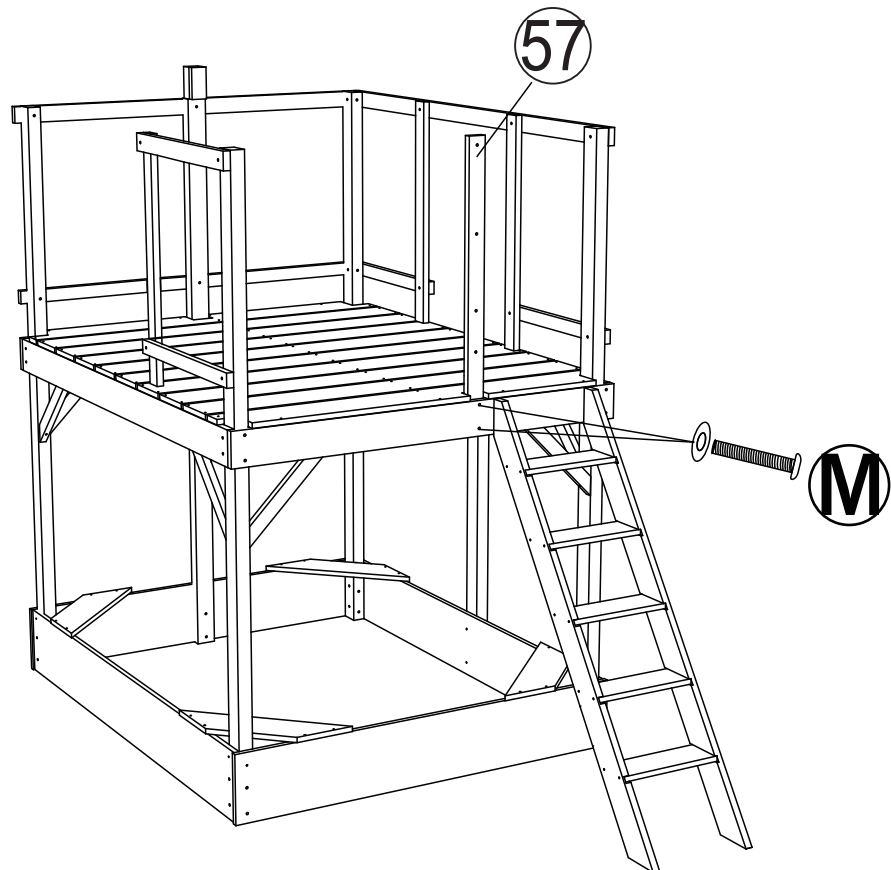

M x 4
M6X40

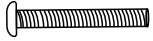

G x 4

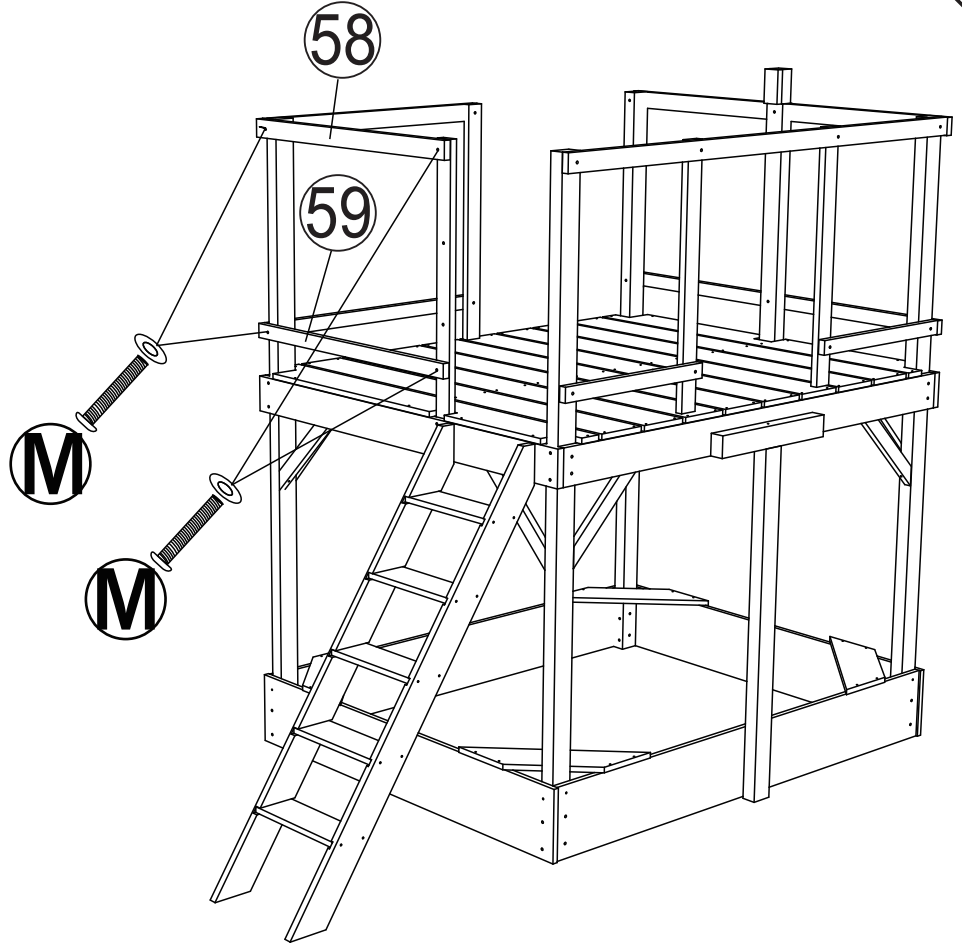

N x 12
M4X25

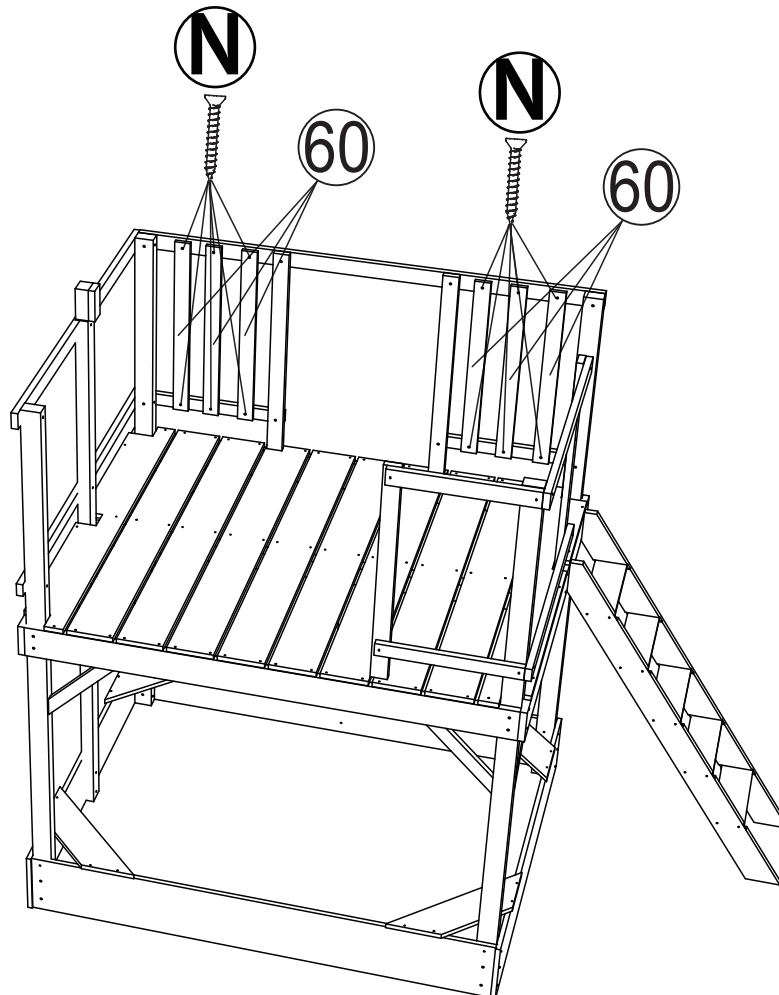

N x 4
M4X25

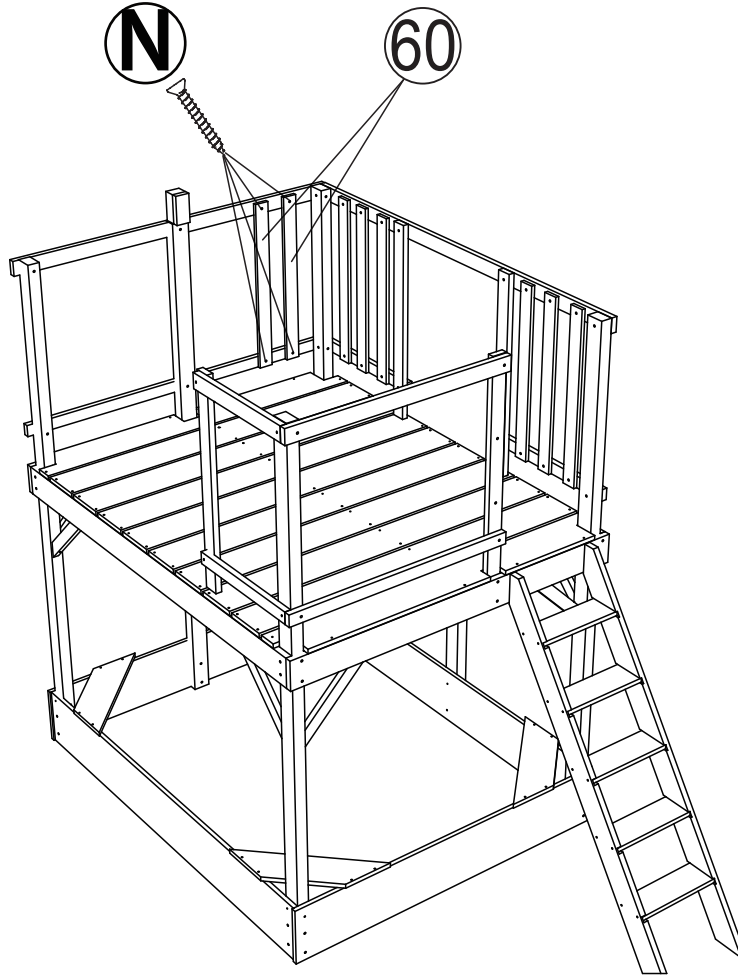

N x 10
M4X25

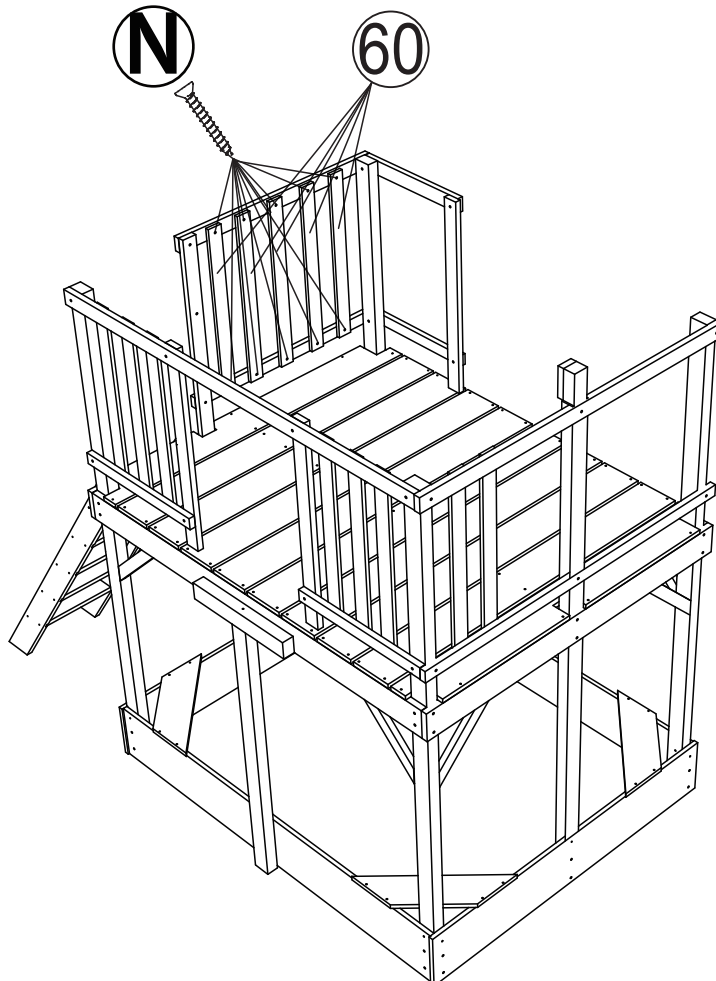

N x 4
M4X25

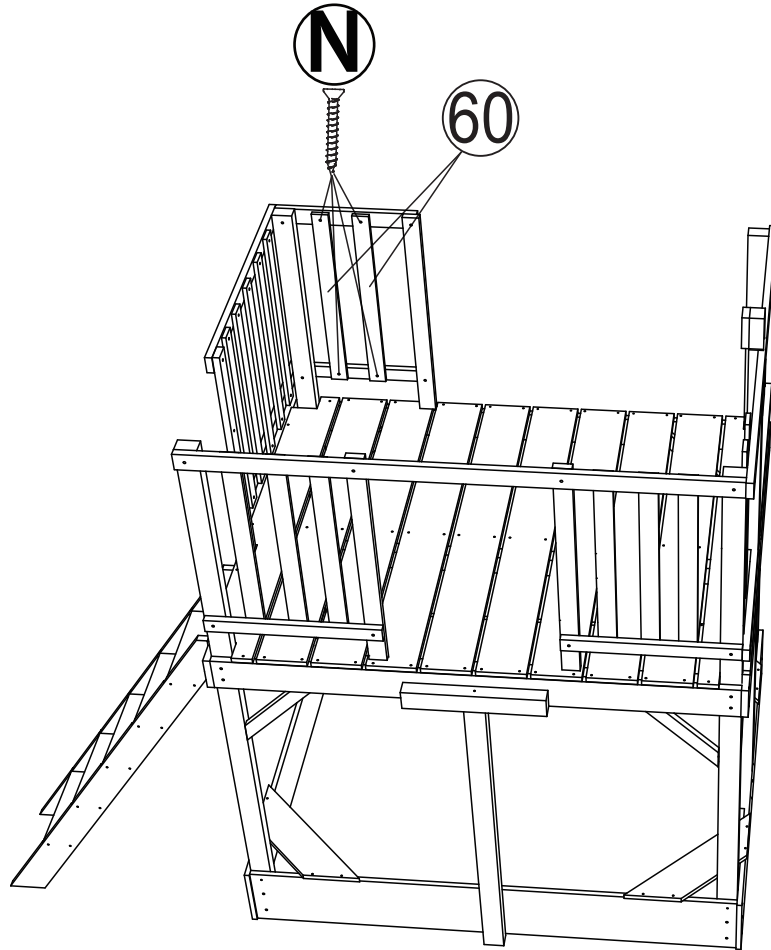
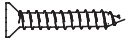

E x8
M3x10



O x2

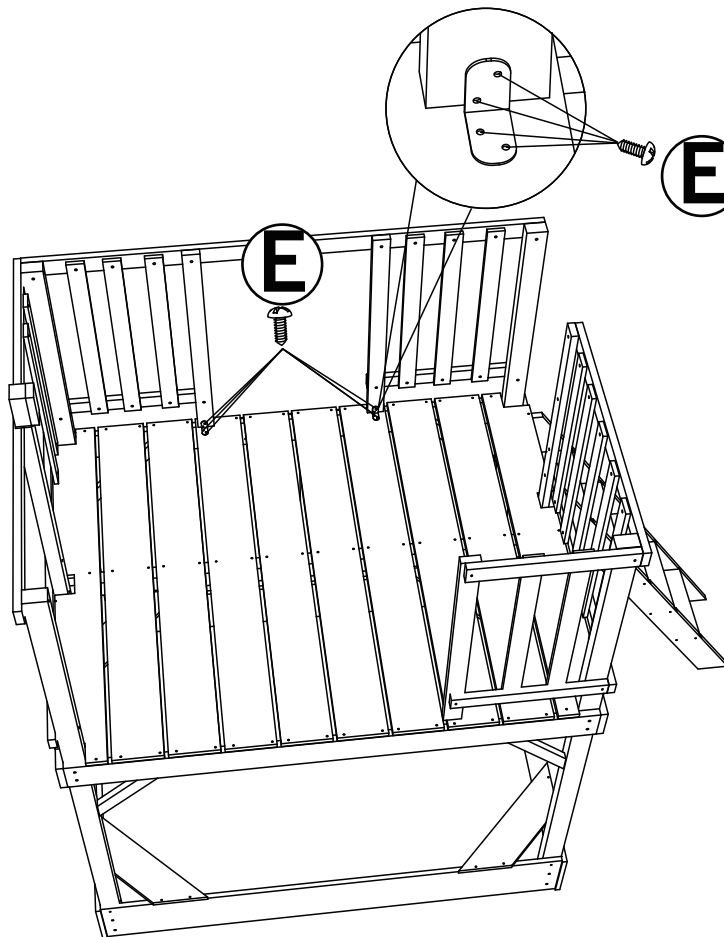

E x8
M3x10



P x2

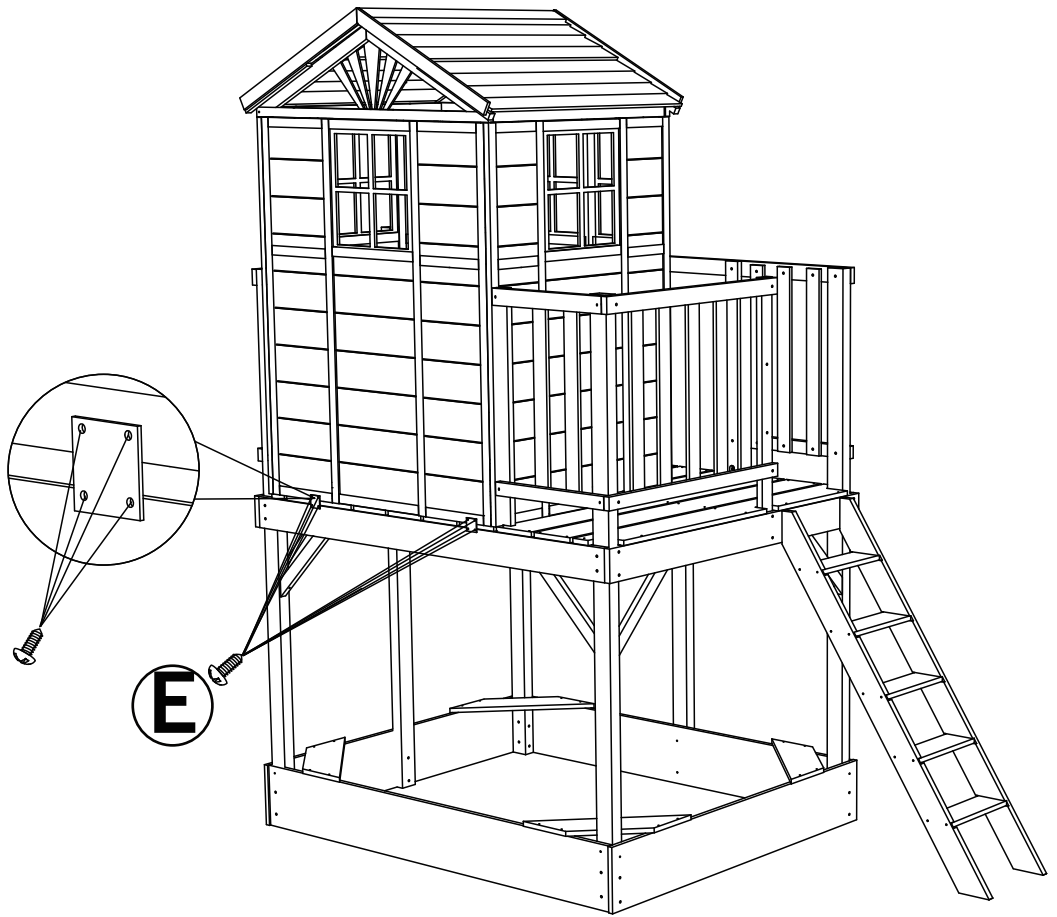
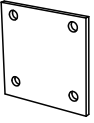

E x8
M3x10



O x2

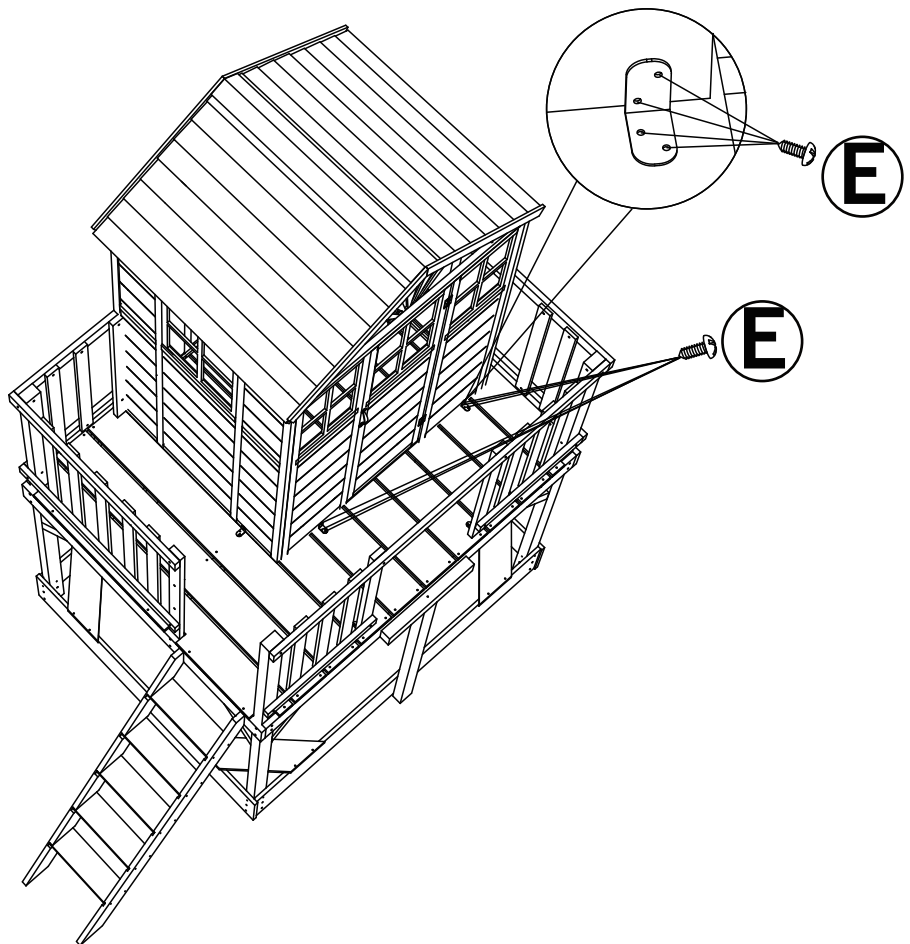

F x 2
M6X60

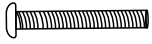

G x 4



Q x 2
M6X20



Z x 2

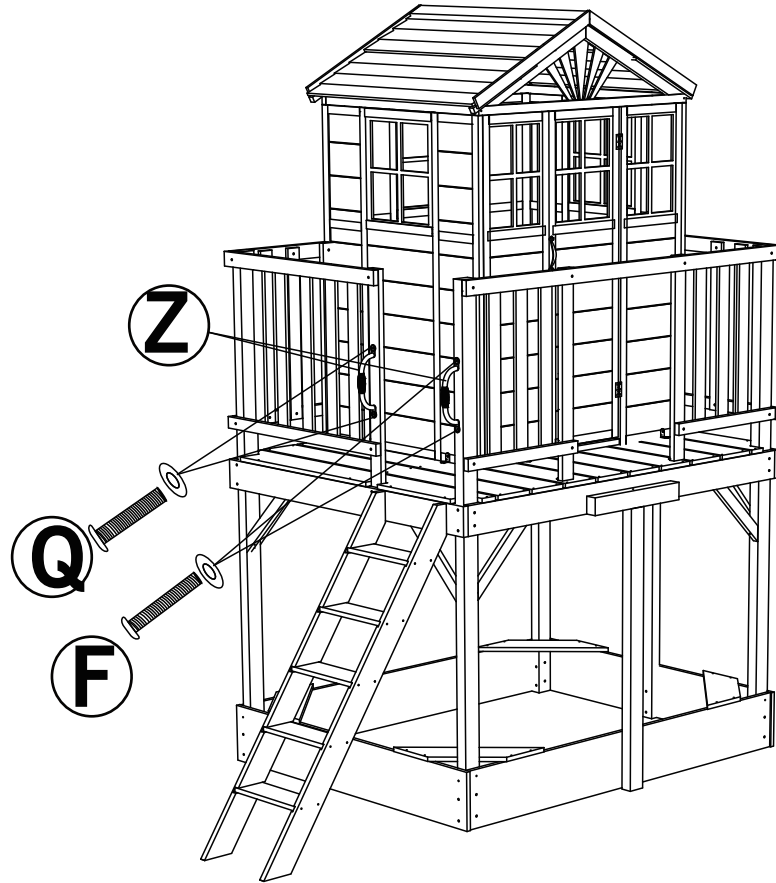

F x 2
M6x60

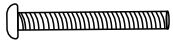

G x 2

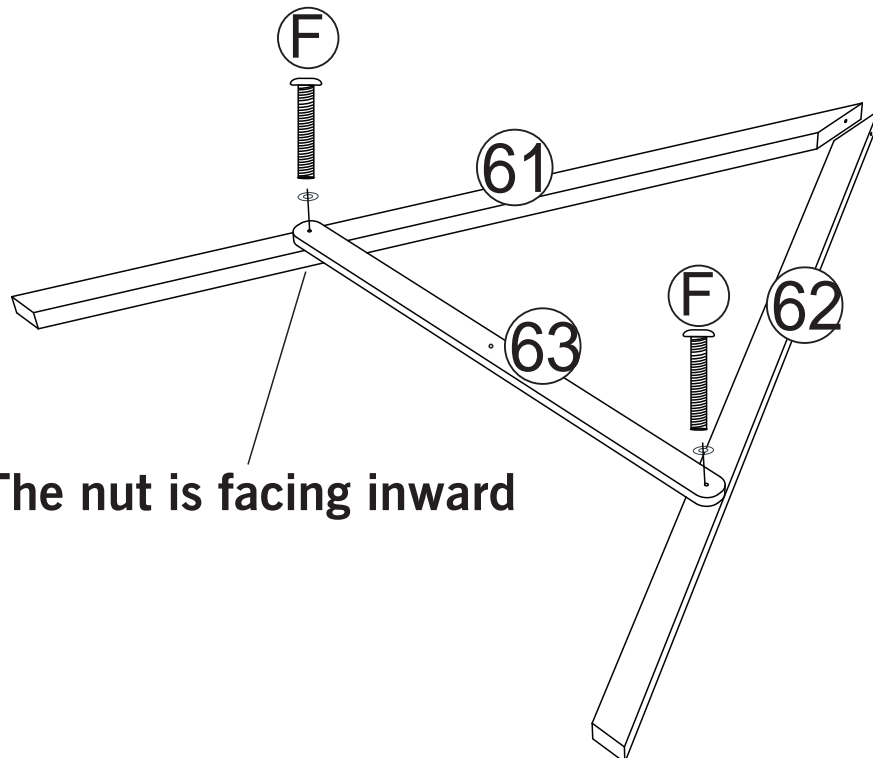

The nut is facing inward

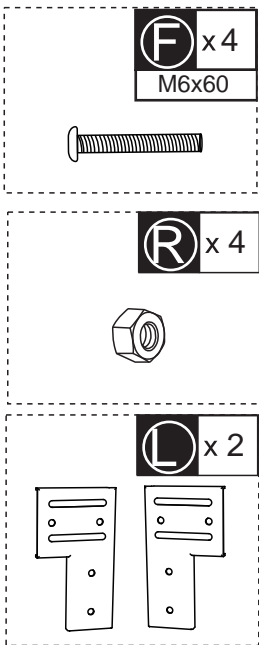
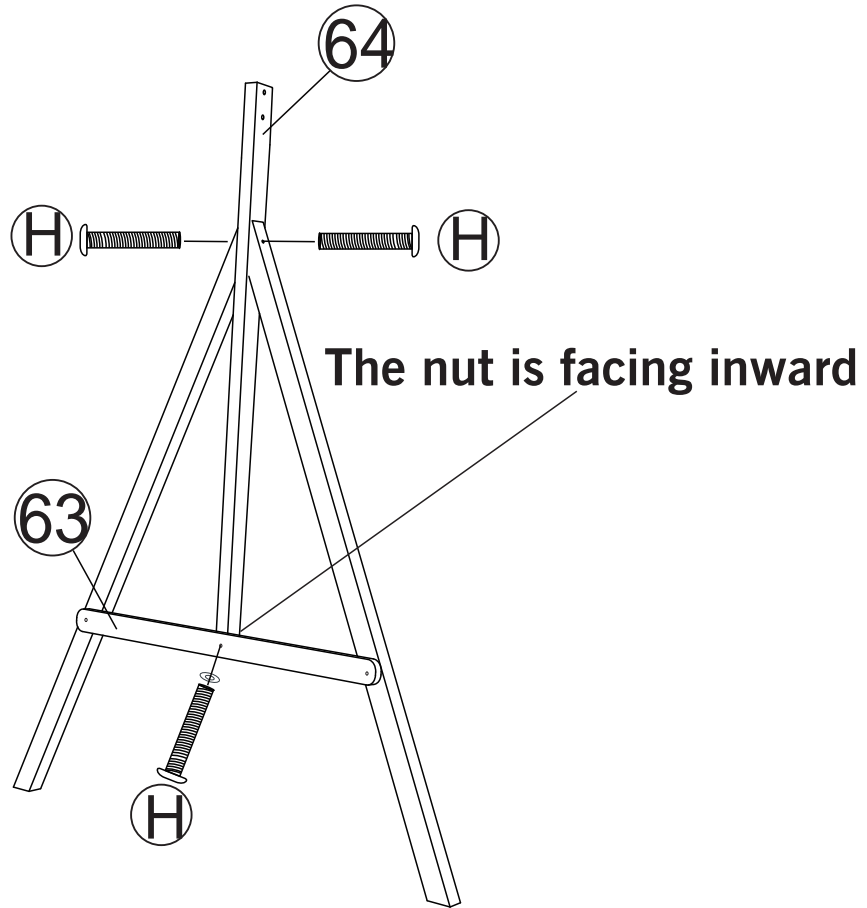
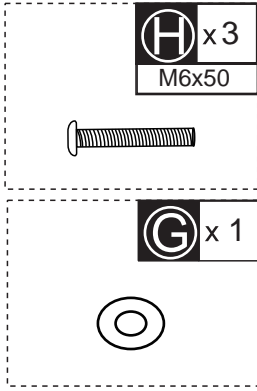

First tighten the screws to 80%,
 and then tighten them after
 completing the 71 step assembly

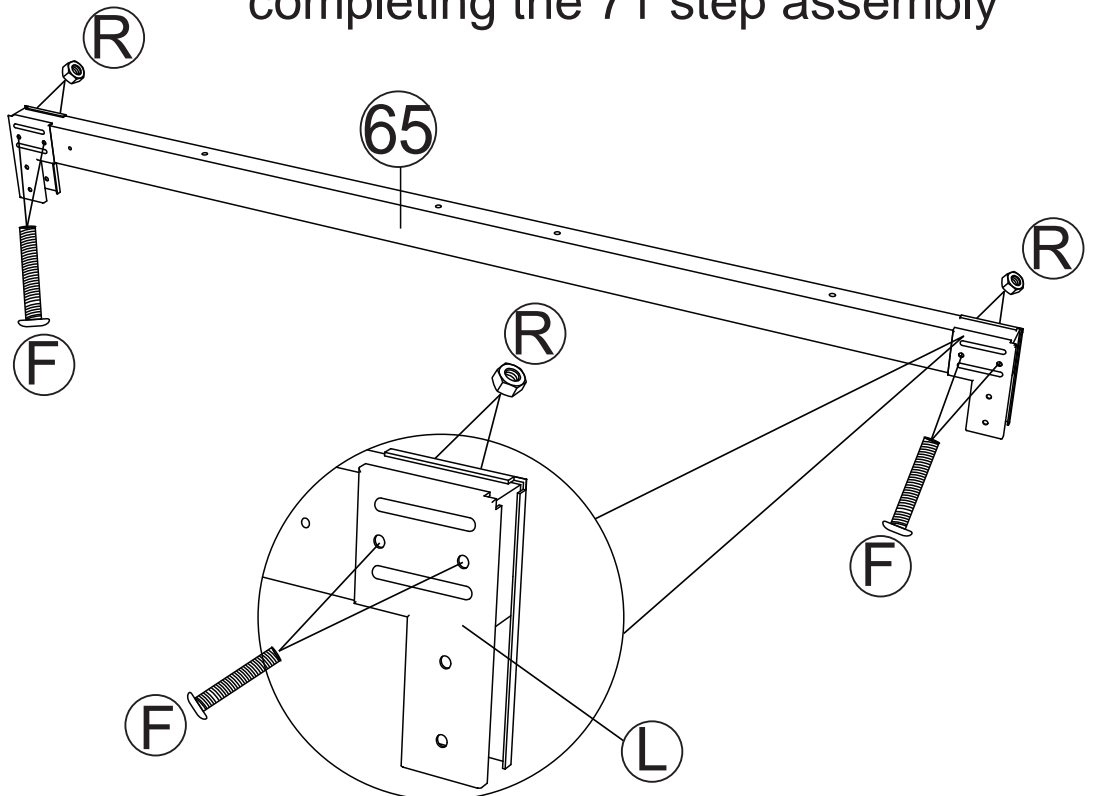

T x4

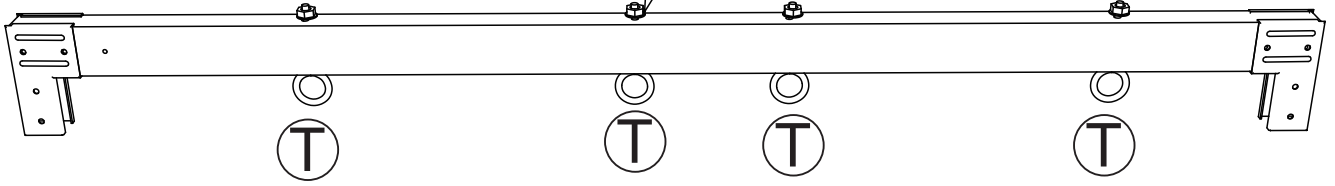
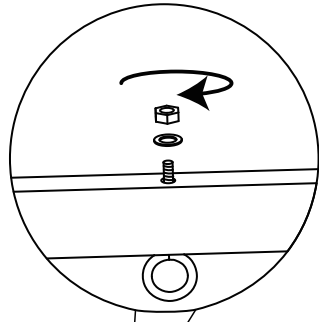
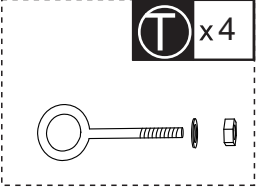

F x2
M6x60



R x2

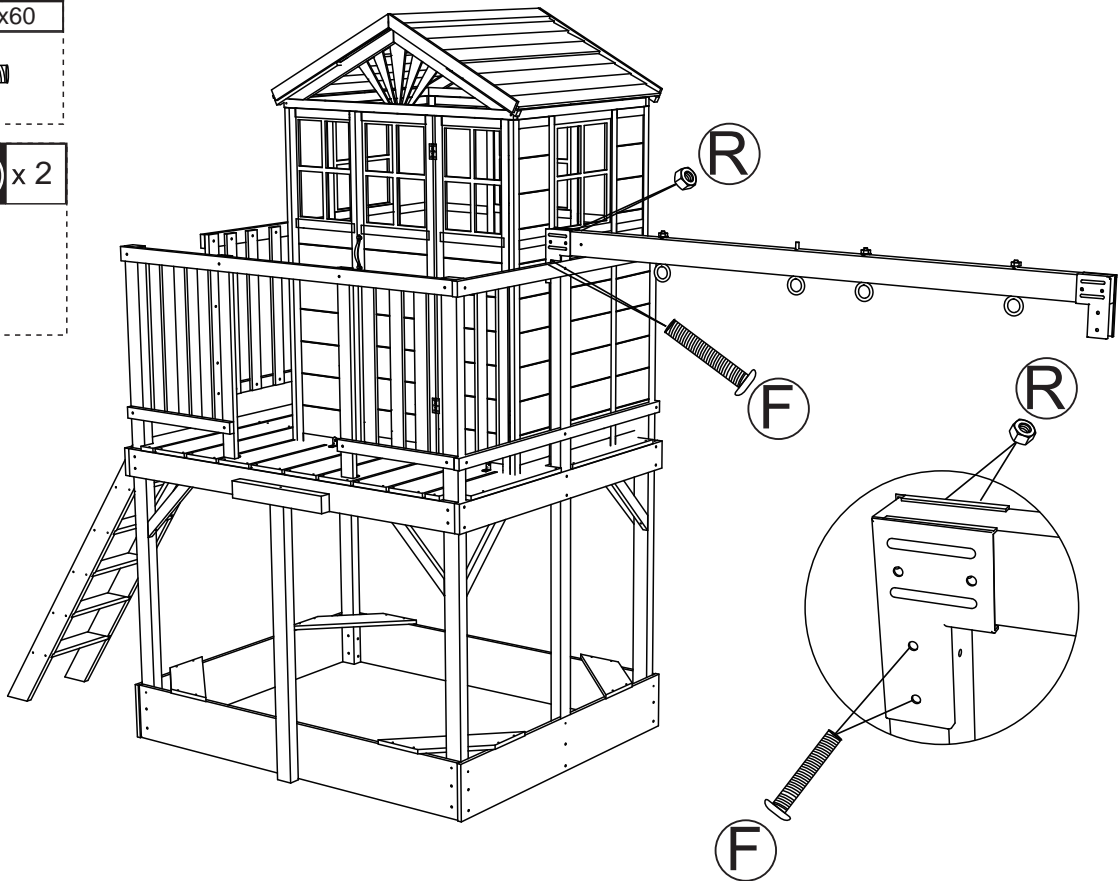

F x 2
M6x60



R x 2

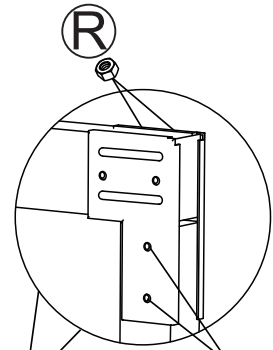
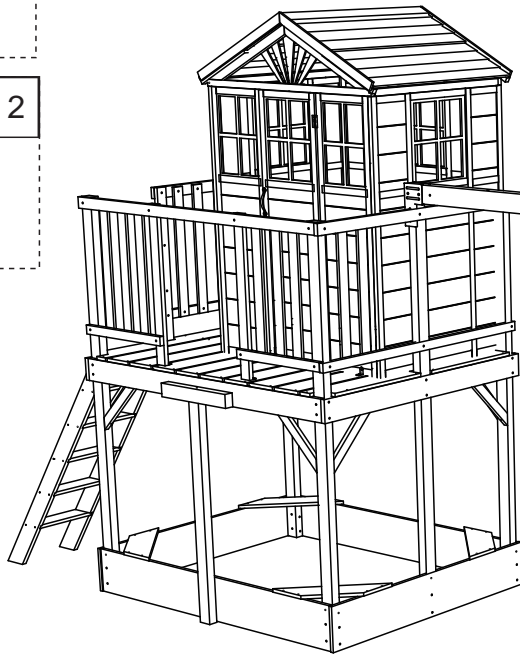

F

F

U x 4

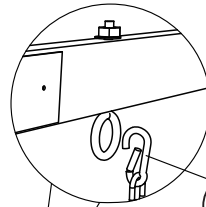
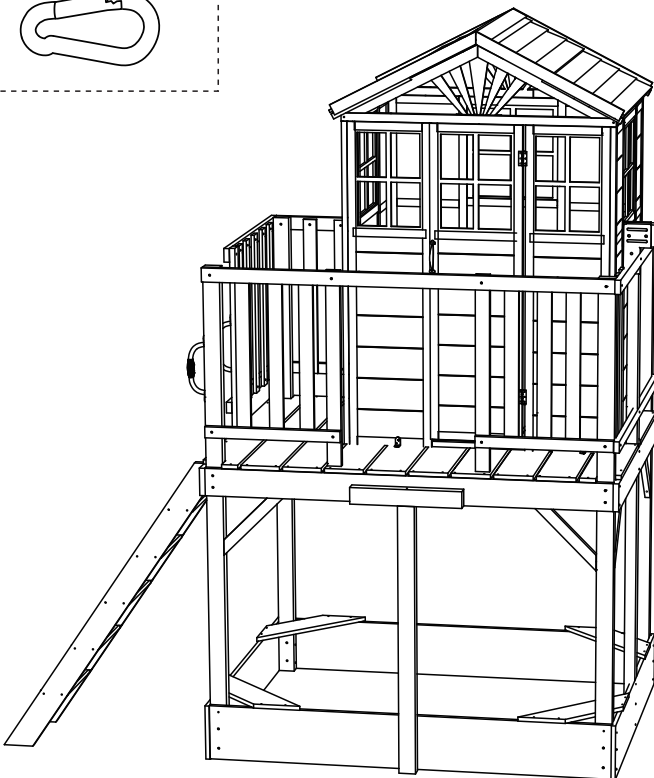
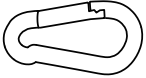

U

66

66

B x 2
M4x20

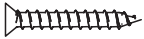

B

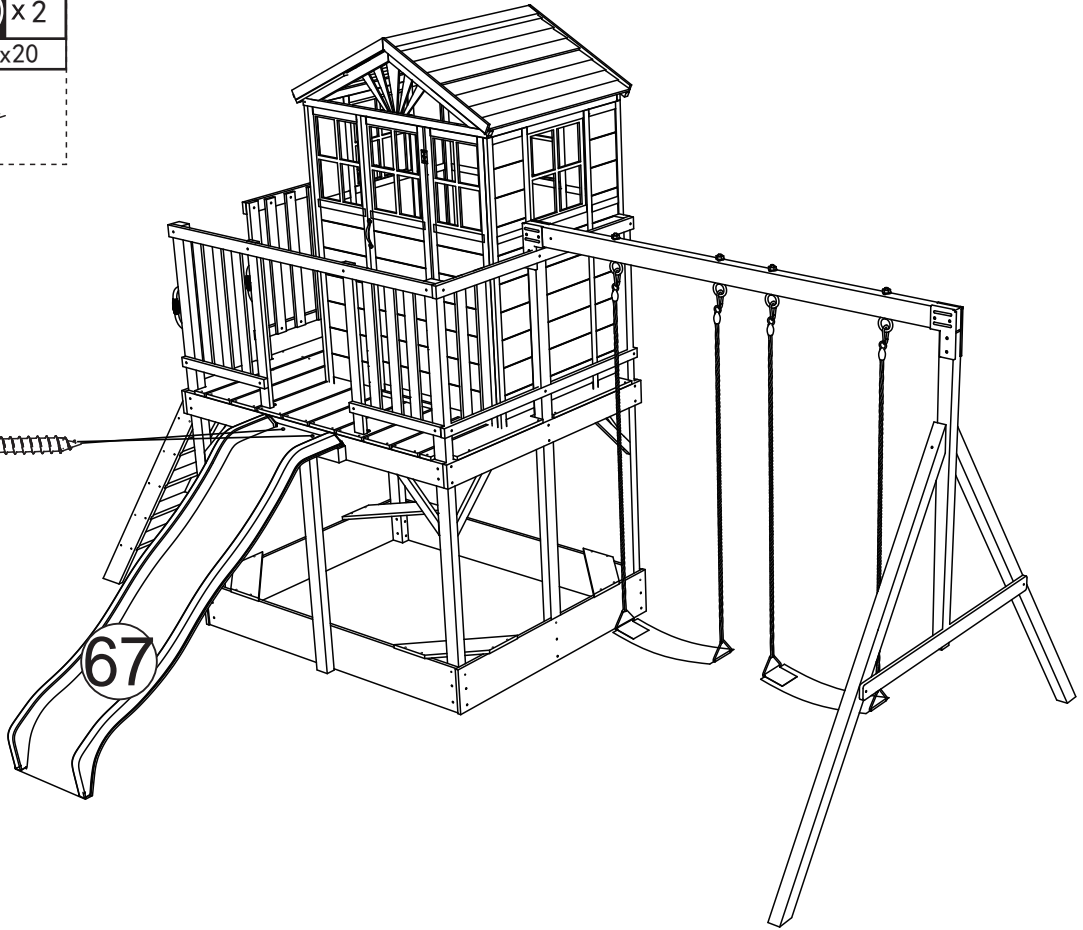

W x 1



X x 1

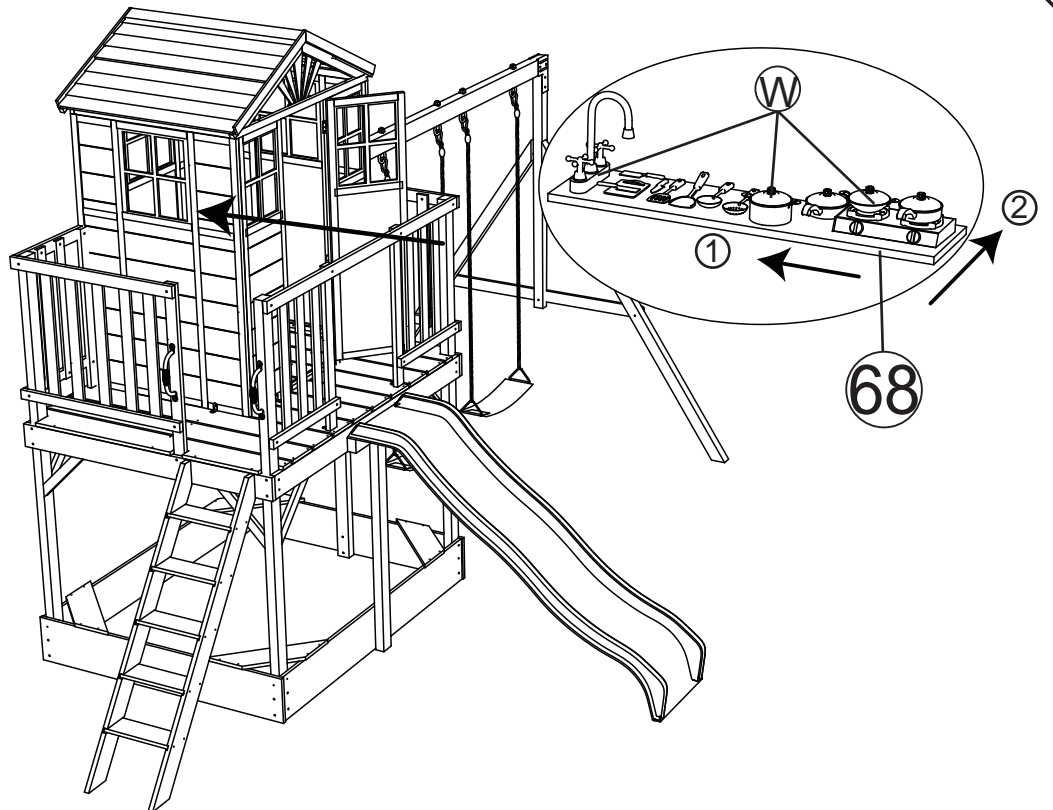
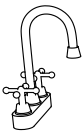

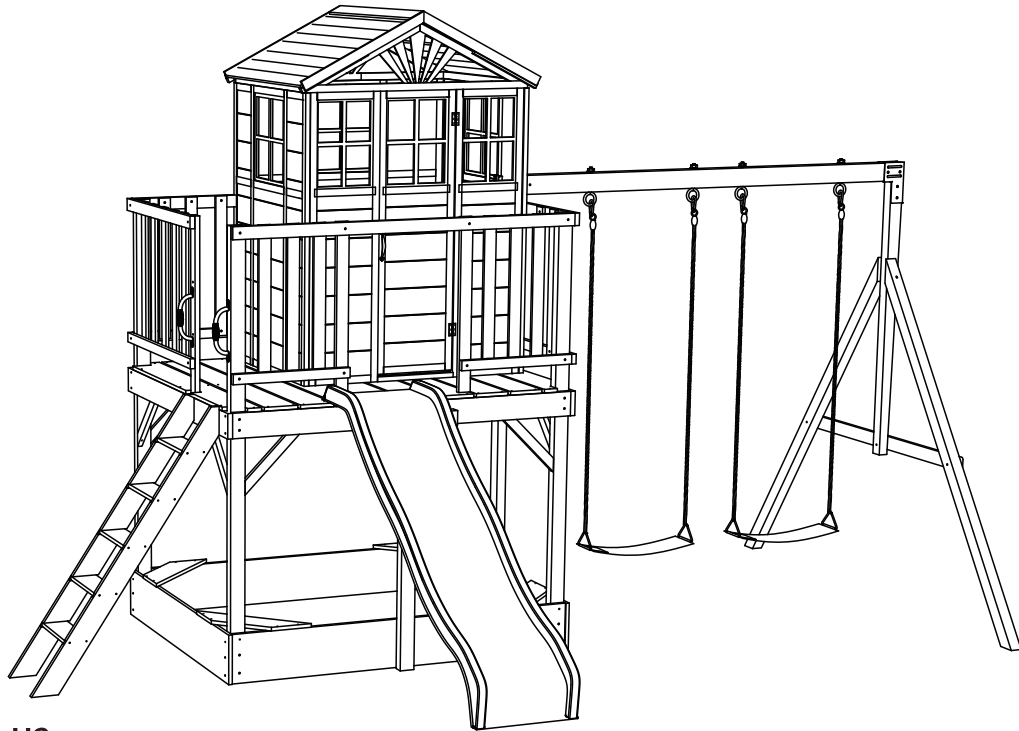
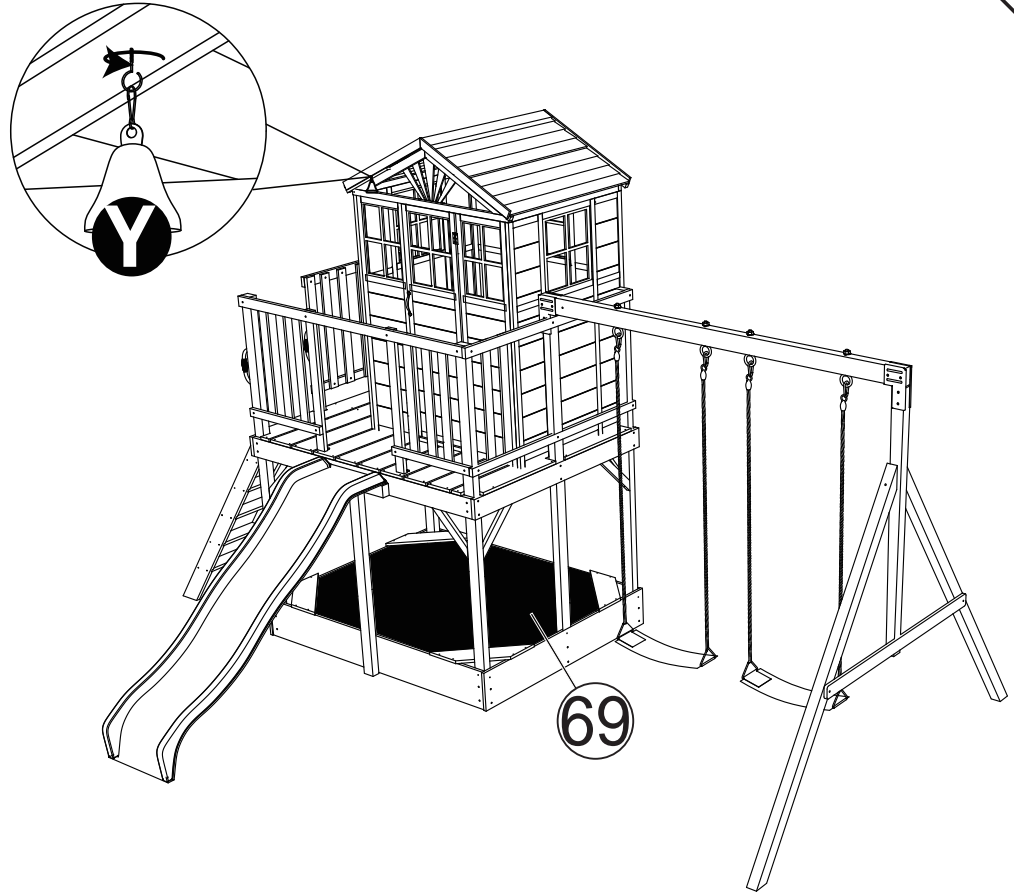
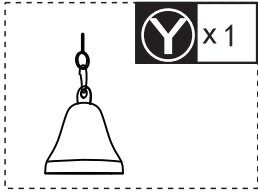

How To Contact US

So glad you have completed the assembly and can enjoy it.

Any problems with the product or shipping issues, please feel free to contact us, and we will try our best to serve and help.

Contact Methods:

If you choose Amazon, going to your Amazon order detail page: Order> Sold By>Contact Seller

(We will guarantee to reply to you within 24 hours. Please don't worry.)