

# Assembly Instruction

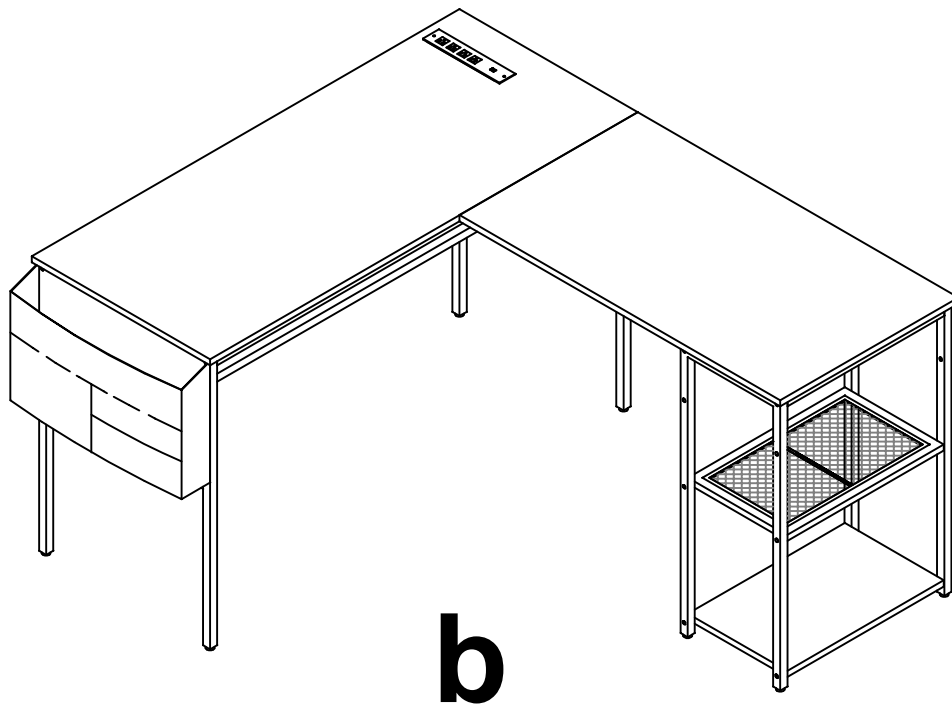

# COMPONENTS ID Nr.

Part Nr.	Qty	Part Nr.	Qty	Part Nr.	Qty
A	1pcs	H	1pcs	Q	1pcs
B	1pcs	J	2pcs		
C	1pcs	K	1pcs		
D	1pcs	L	1pcs		
E	1pcs	M	1pcs		
F	1pcs	N	2pcs		
G	1pcs	P	1pcs		

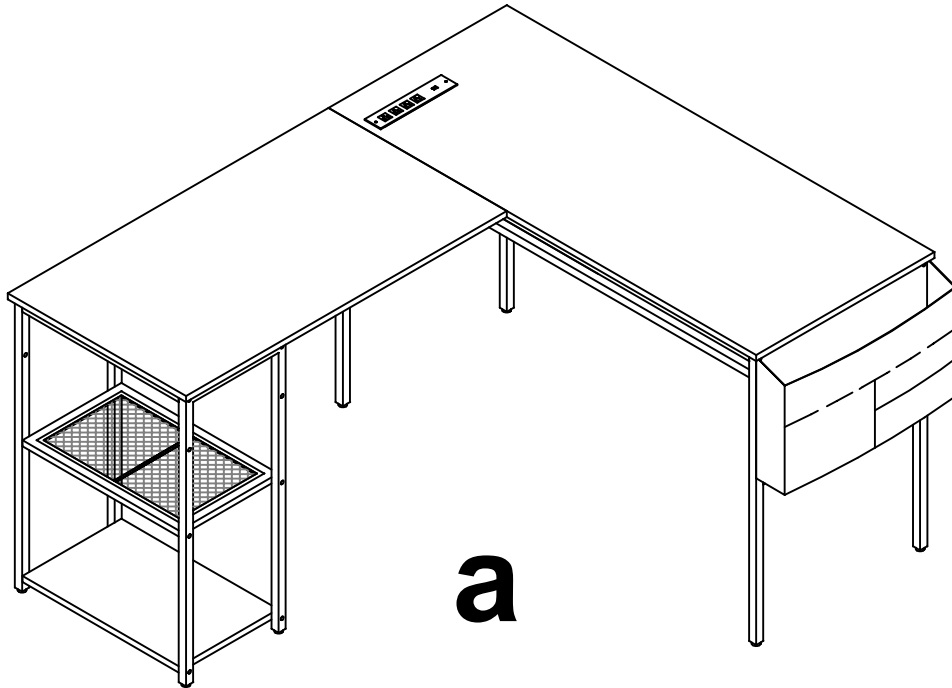
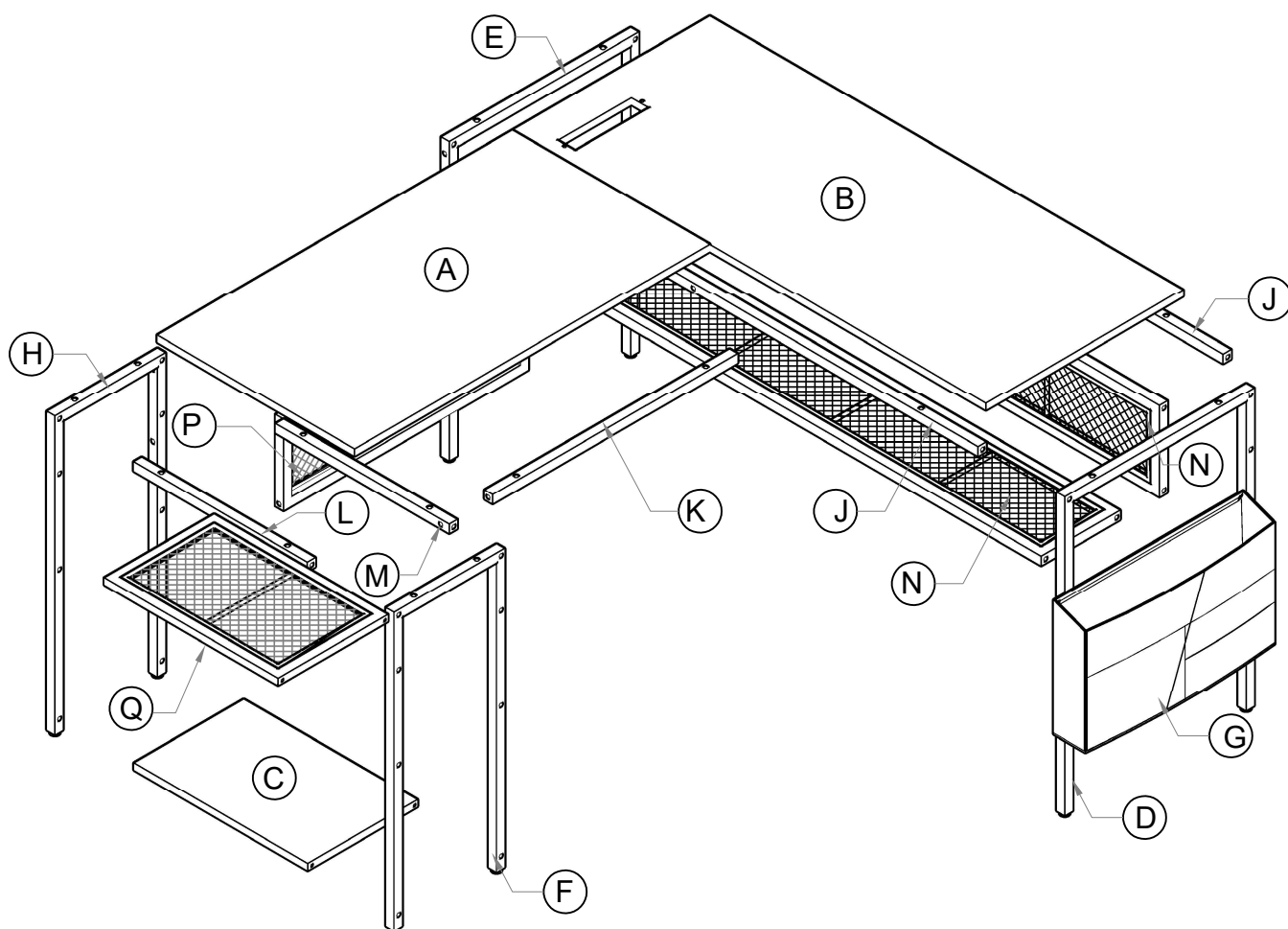

# HARDWARE LIST

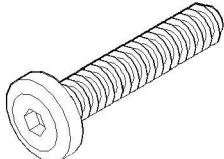
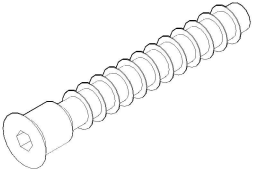
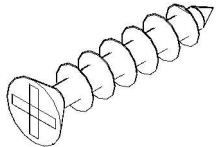
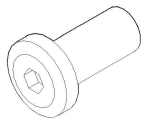
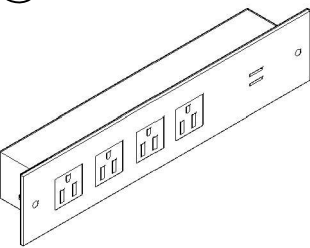
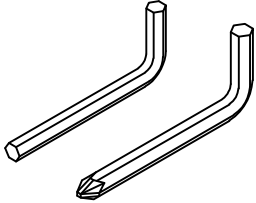
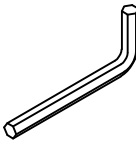
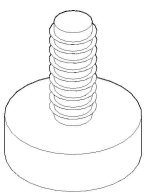
<p>① x 46</p>  <p>M6x30mm</p>	<p>② x 4</p>  <p>D5x50mm</p>	<p>③ x 2</p>  <p>D3.5x15mm</p>	<p>④ x 2</p>  <p>6x15</p>
<p>⑤ x 1</p> 	<p>⑥ x 1</p>  <p>#4</p>	<p>⑦ x 1</p>  <p>#3</p>	<p>⑧ x 8</p> 

1

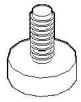

8 x 8

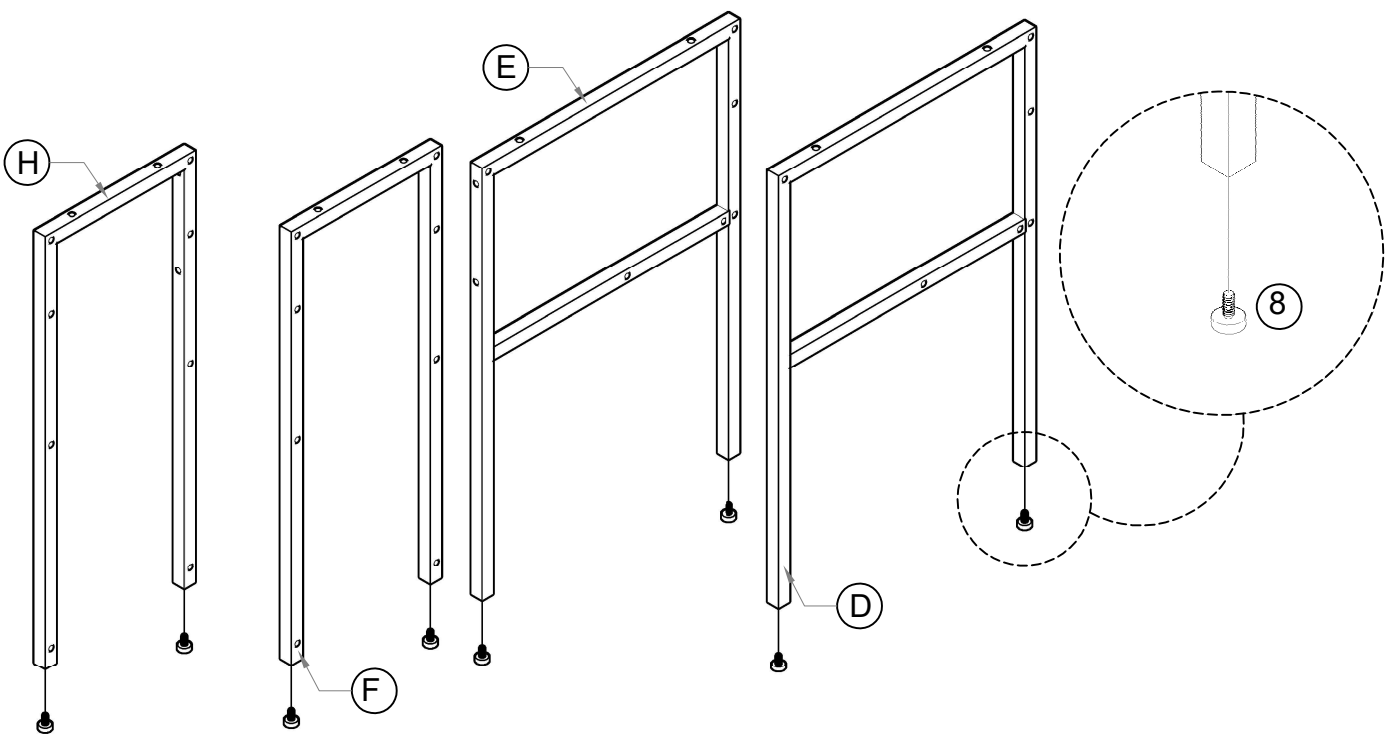

2

M6x30mm

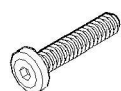

1 x 8

D5x50mm



2 x 4

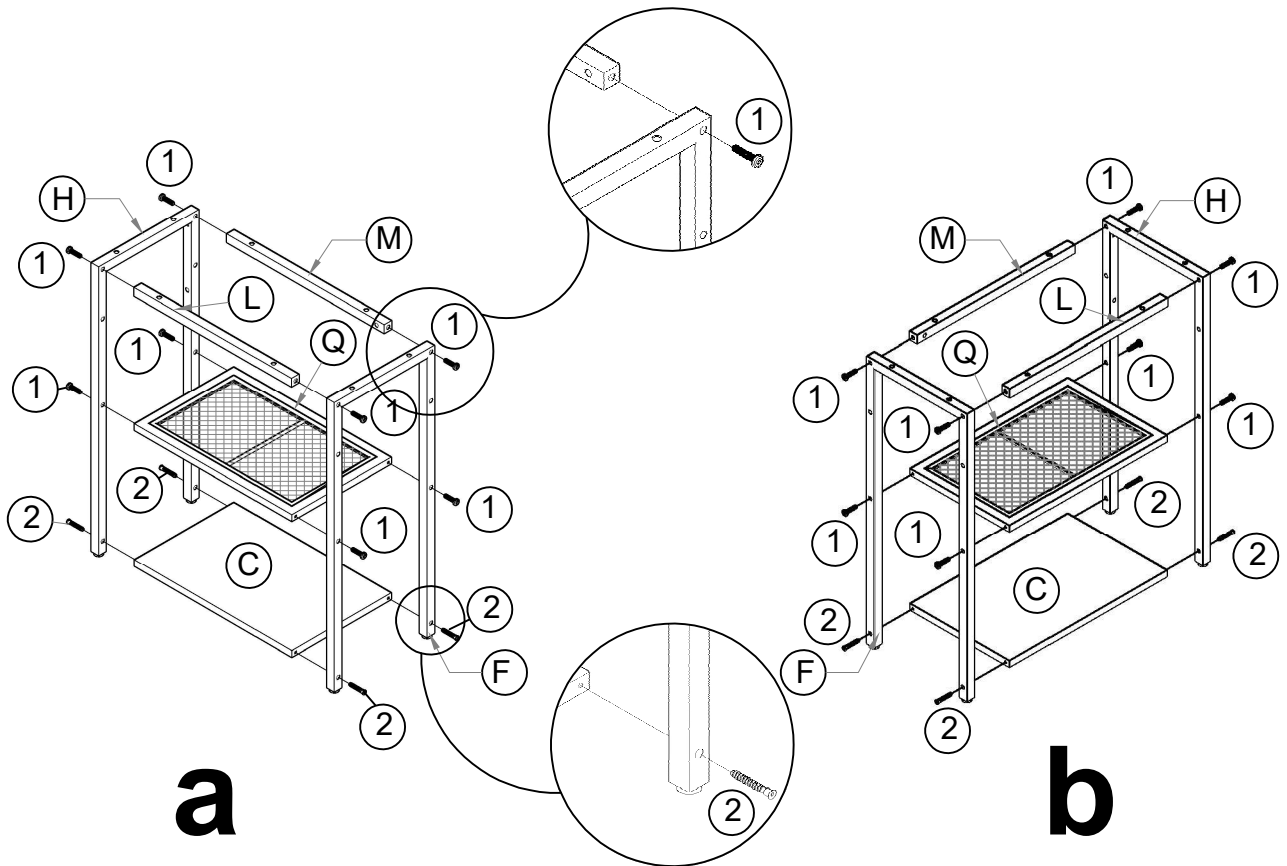

3

M6x30mm

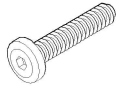

①x 12

Noted there is a arrow label here, the arrow head need forward to part #D.

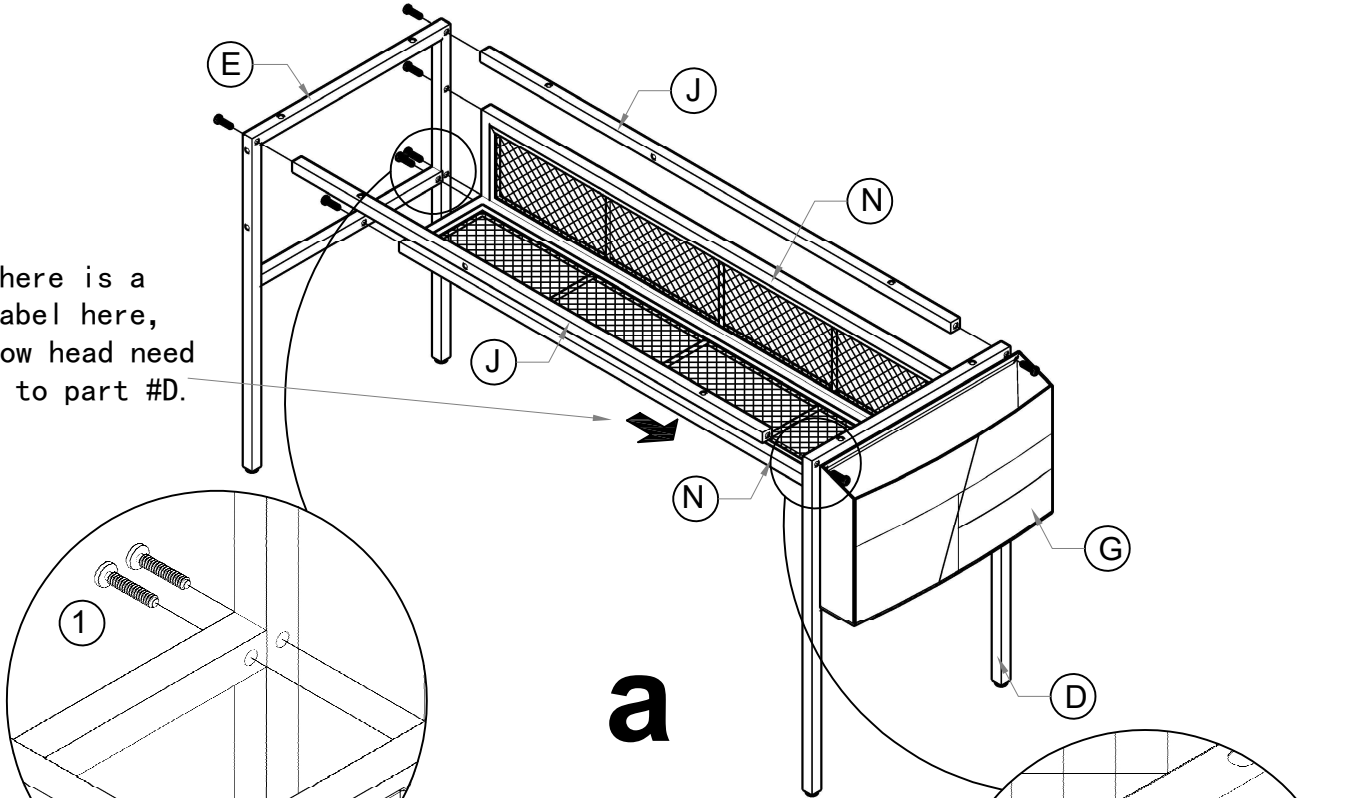

**a**

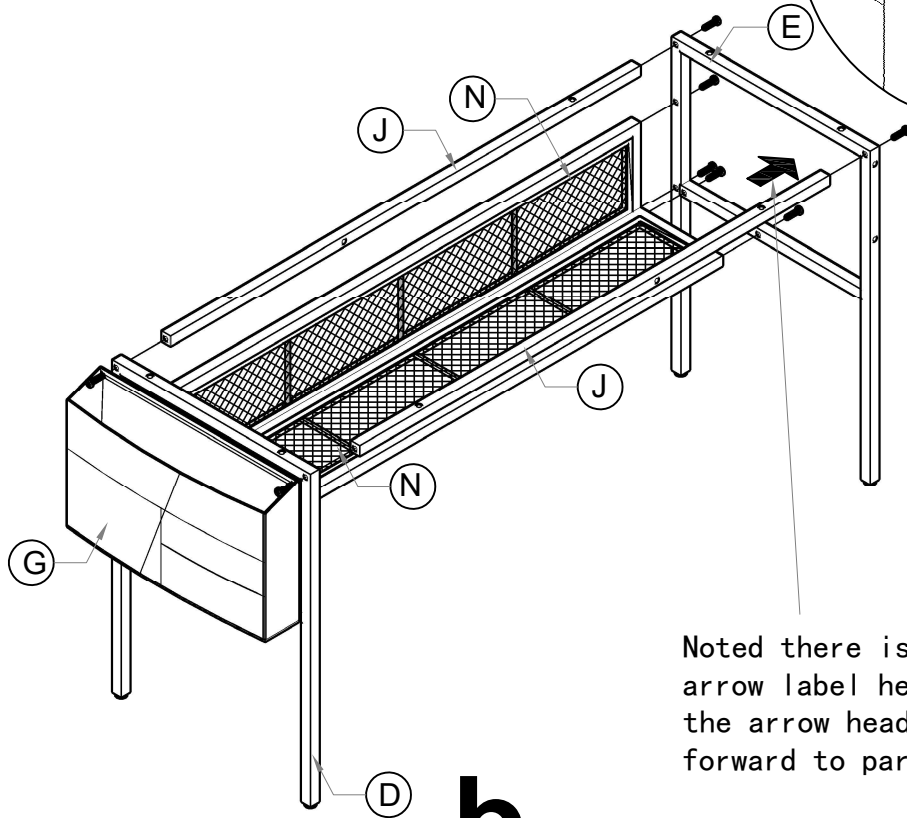

**b**

Noted there is a arrow label here, the arrow head need forward to part #E.

# PRODUCT ASSEMBLY

# 4

M6x30mm

6x15

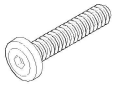

① x 6



④ x 2

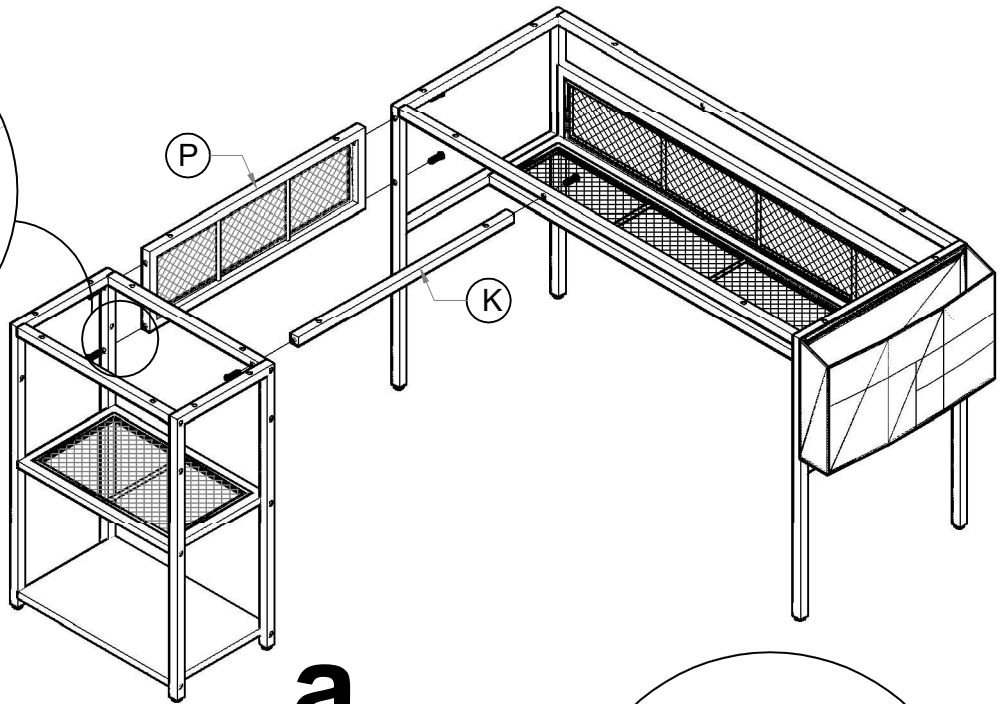
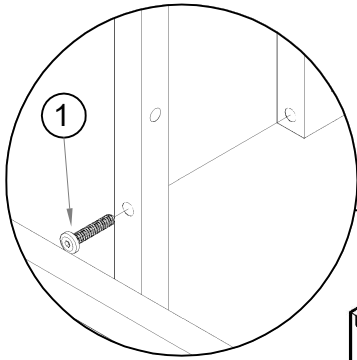

# a

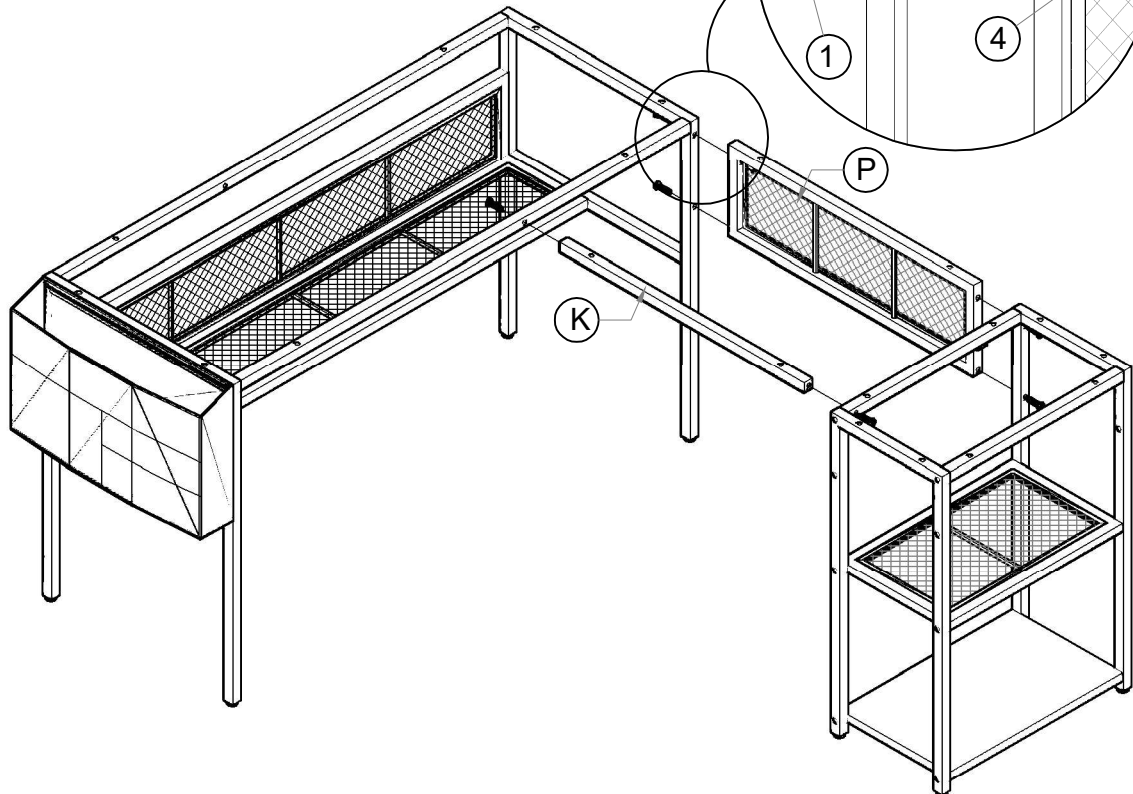
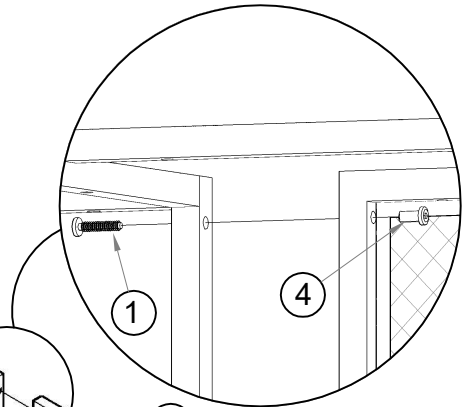

# b

**5**

M6x30mm

D3.5x15mm

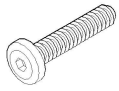

① x 20

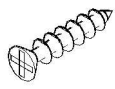

③ x 2

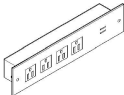

⑤ x 1

Recommendation: Use  
Power Tools to  
install Screw ③

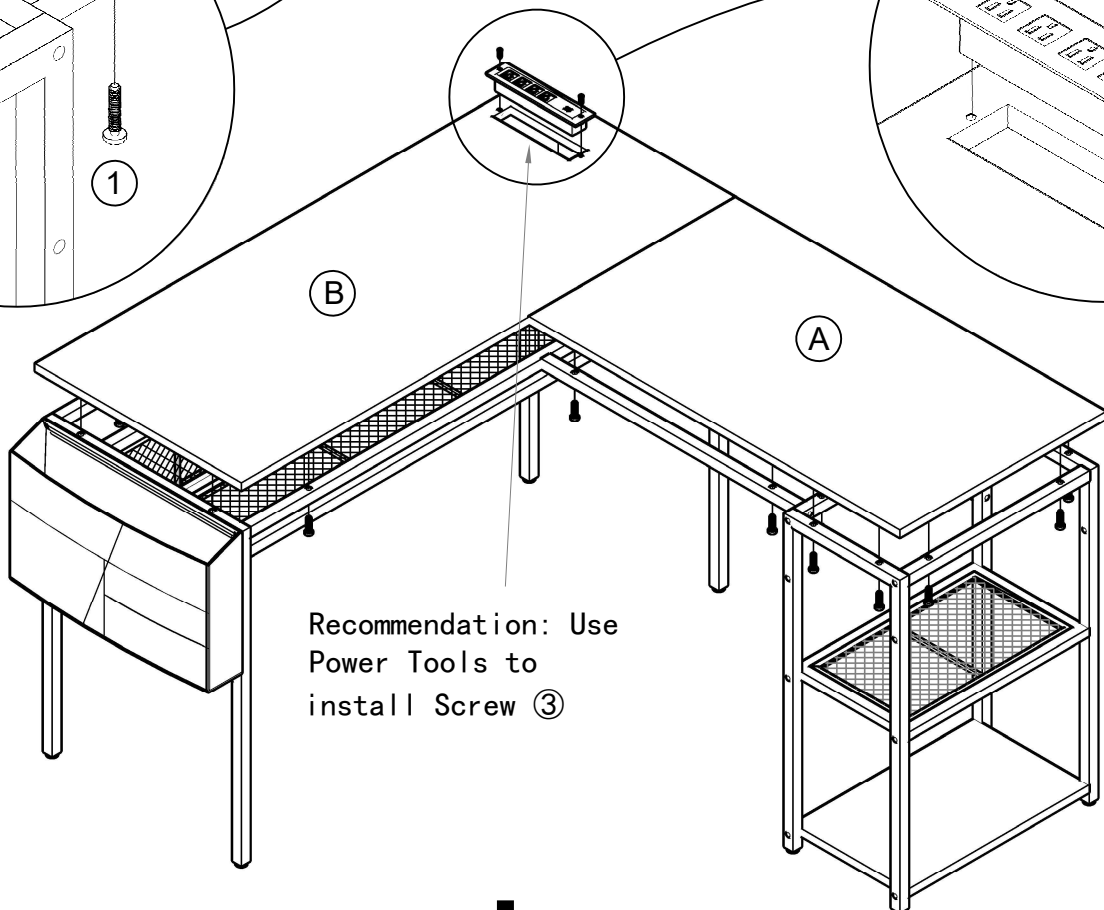
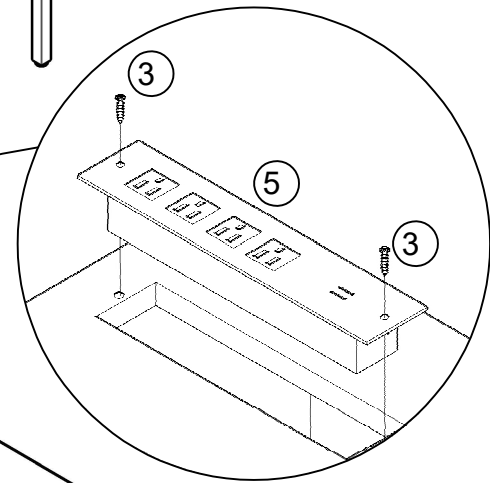
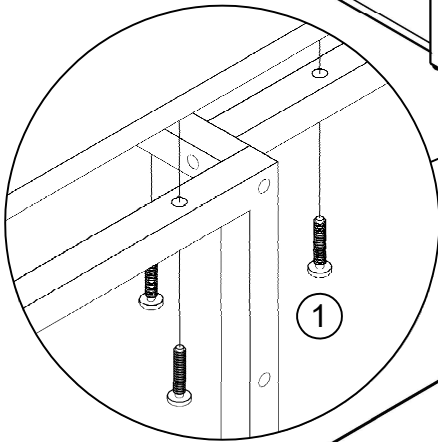
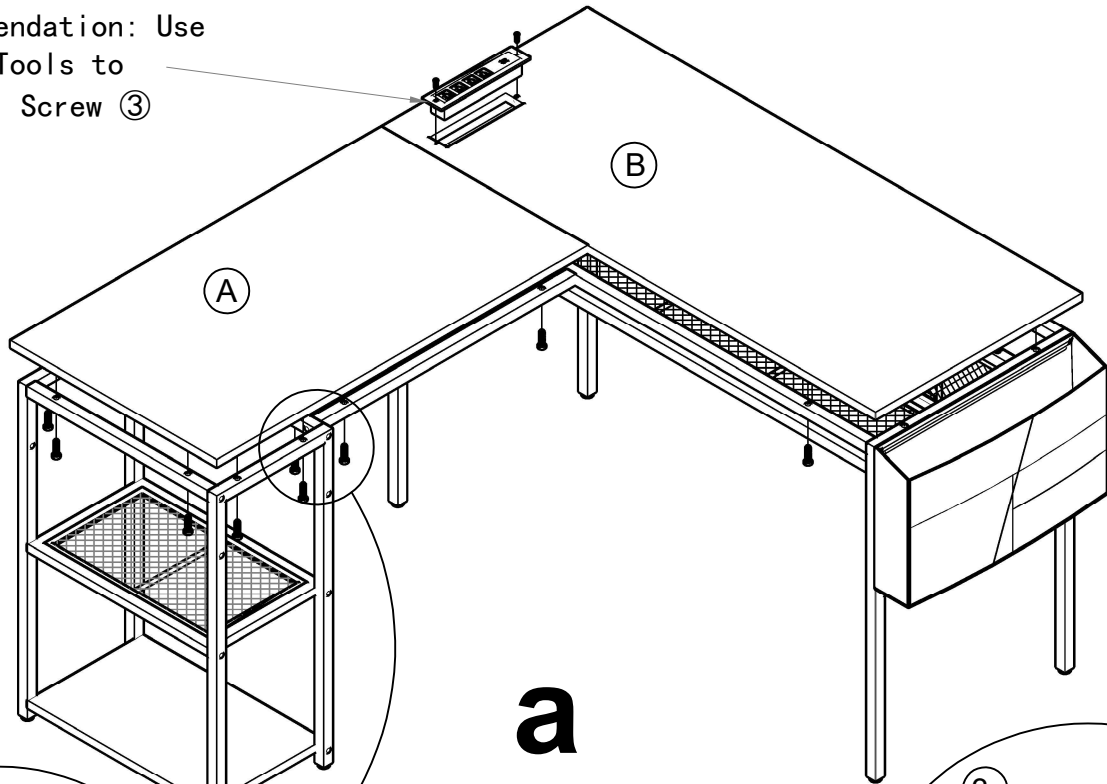

Recommendation: Use  
Power Tools to  
install Screw ③

**b**

# 6

