



CARE AND MAINTENANCE

Do not use acids or alkaline cleaning agents. Sharp objects will damage and scratch the surface. Wipe the surface with a soft, damp cloth.

NOTICE

- * Please make sure that you have all parts indicated before you begin assembly of this item
- * This item should be assembled on a soft surface to prevent scratching the finish during assembly
- * This item may require periodic tightening

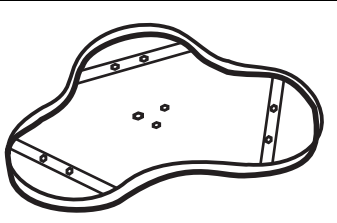
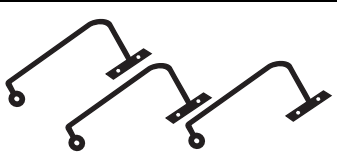
Part List and Hardware List

	DESCRIPTION	PICTURE	QUANTITY
I	TABLE TOP (T)		1X
II	METAL LEGS (A,B,C)		3X
III	CROSS SCREW		10X
IV	L KEY TO TIGHTENING SCREWS (D)		1X

PREPARATION

Before beginning assembly of product, make sure all parts are present. Compare parts with package contents list and hardware contents list. If any part is missing or damaged, do not attempt to assemble the product. Estimated Assembly Time: 10 minutes.

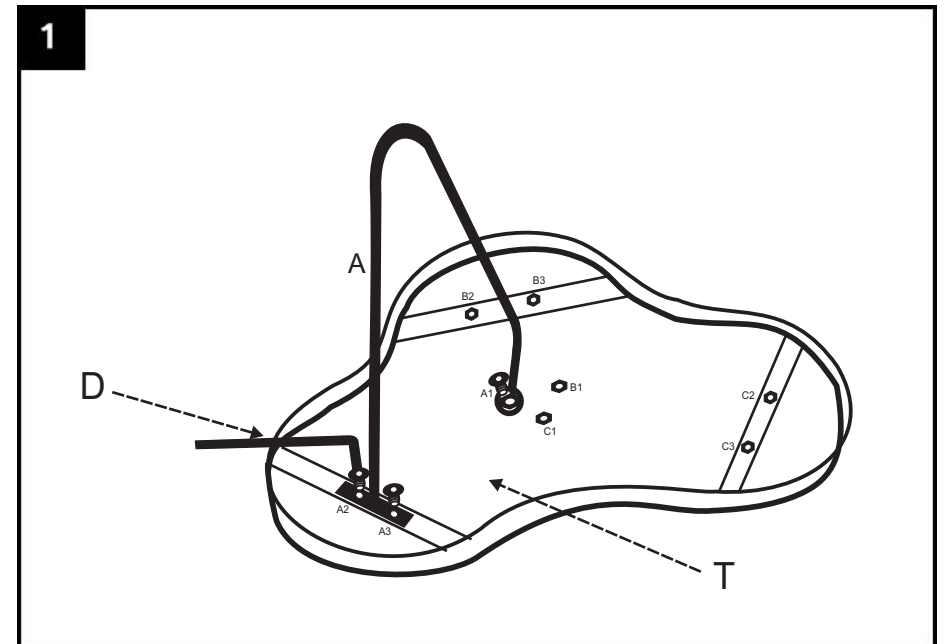

Step 1

Put a leg A and place the hole of table top Bottom (T) on positioning A1,A2,A3 then put 3 cross screw © on Tighten with L key (D) clockwise.

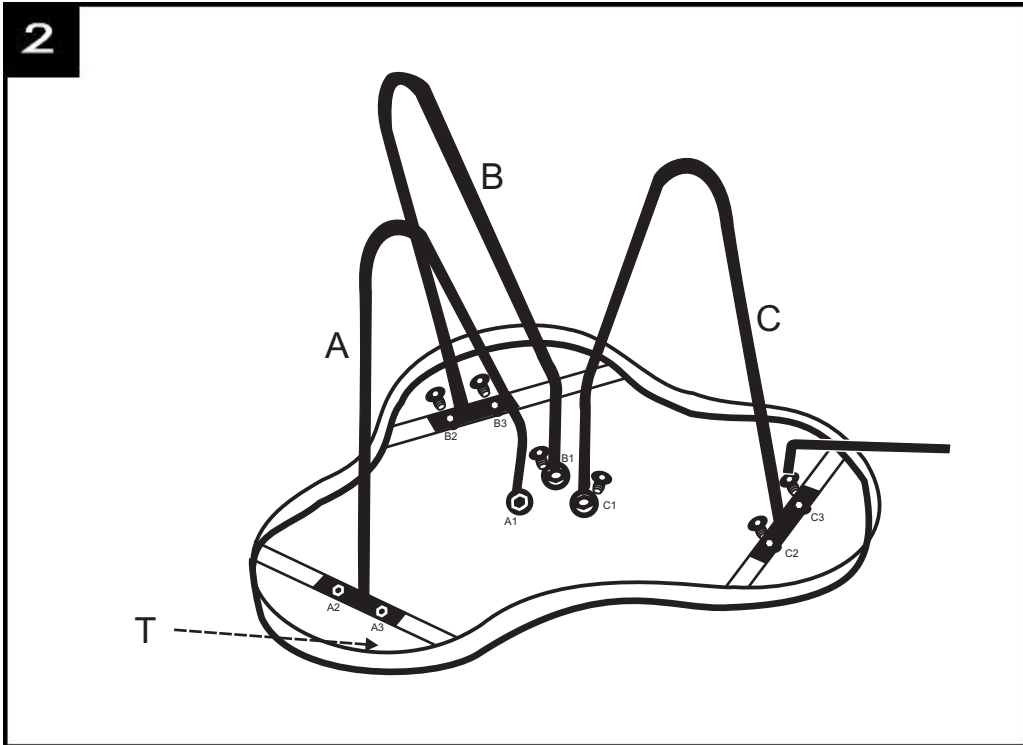

Step 2

Accodiindly first leg please Place both legs on positioning B1,B2,B3 & C1,C2,C3 and tighten with cross screws & L-Key(D) clockwise.

Product Dimensions : 31" X 31" X 17"

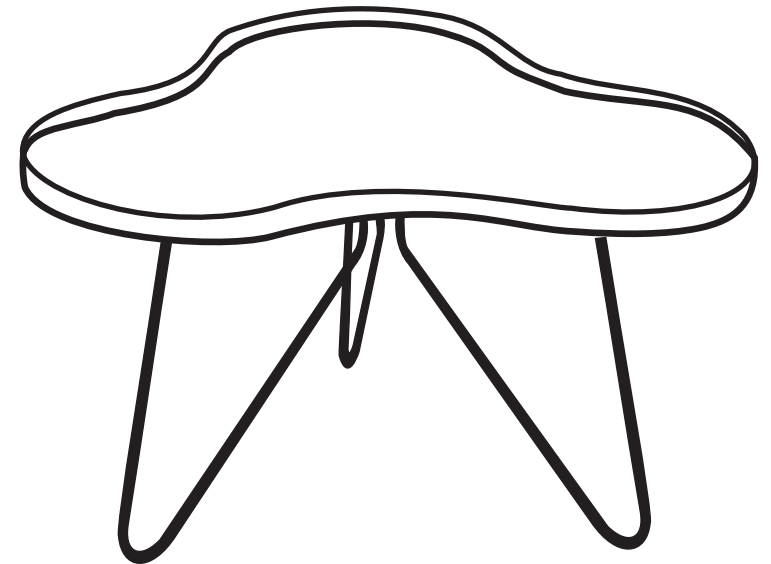



CARE AND MAINTENANCE

Do not use acids or alkaline cleaning agents. Sharp objects will damage and scratch the surface. Wipe the surface with a soft, damp cloth.

NOTICE

- * Please make sure that you have all parts indicated before you begin assembly of this item
- * This item should be assembled on a soft surface to prevent scratching the finish during assembly
- * This item may require periodic tightening

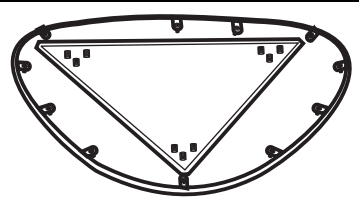
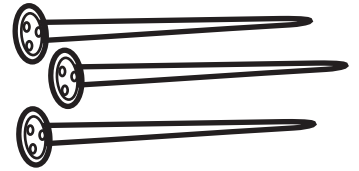
Part List and Hardware List

DESCRIPTION	PICTURE	QUANTITY
I TABLE TOP (T)		1X
II METAL LEGS (A,B,C)		3X
III NUTS		10X
IV TOOL ROLL KEY TO TIGHTENING NUT (D)		1X

PREPARATION

Before beginning assembly of product, make sure all parts are present. Compare parts with package contents list and hardware contents list. If any part is missing or damaged, do not attempt to assemble the product. Estimated Assembly Time: 10 minutes.

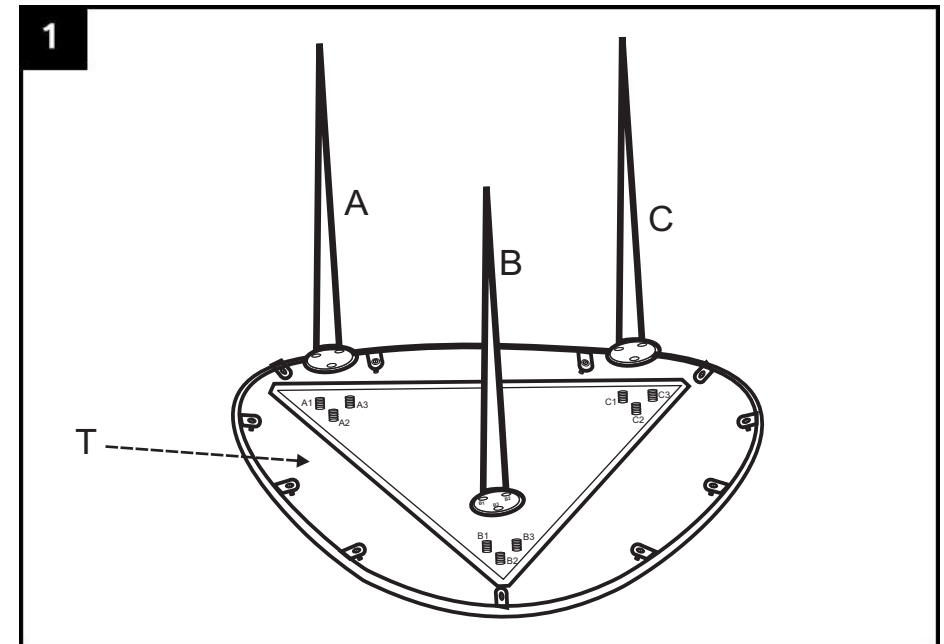

Step 1

Connect a leg (A) on the bottom of table top (T) Positioning A1, A2, A3 Respectively for B & C Legs.

Product Dimensions : 37" X 37.5" X 19"

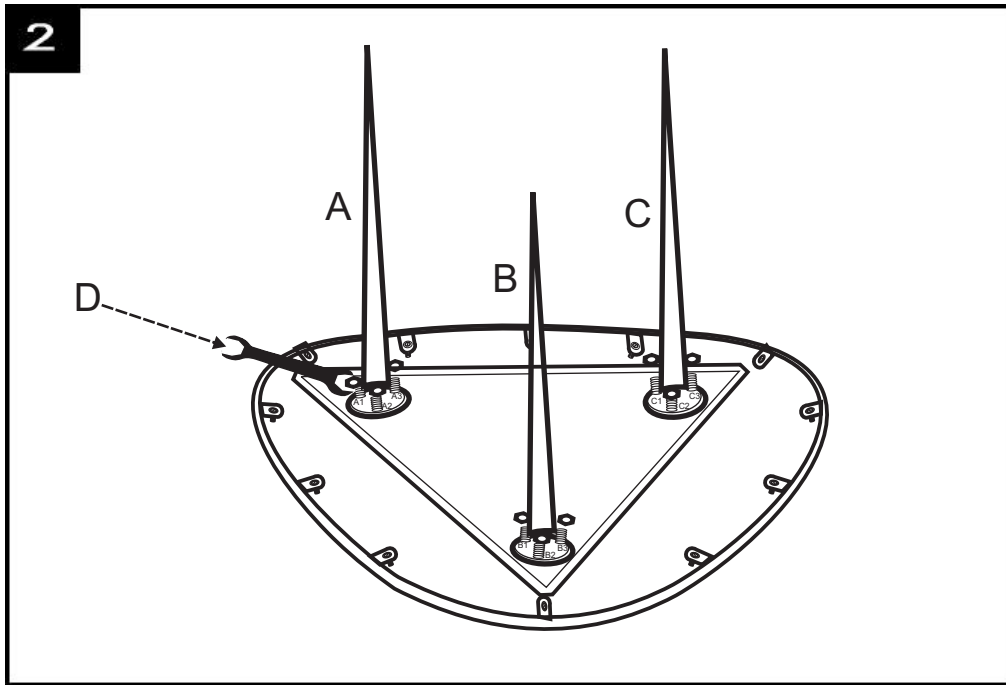

Step 2

Tighten the legs with Nuts on bolt (A1,A2,A3) with Roll Key clockwise.
Respectively for leg B&C.



CARE AND MAINTENANCE

Do not use acids or alkaline cleaning agents. Sharp objects will damage and scratch the surface. Wipe the surface with a soft, damp cloth.

NOTICE

- * Please make sure that you have all parts indicated before you begin assembly of this item
- * This item should be assembled on a soft surface to prevent scratching the finish during assembly
- * This item may require periodic tightening

Part List and Hardware List

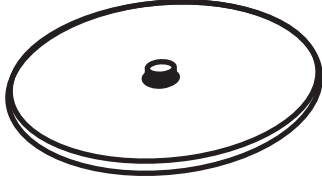
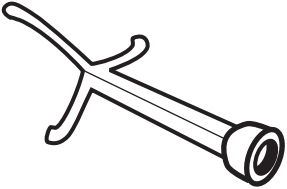
	DESCRIPTION	PICTURE	QUANTITY
A	TABLE TOP		1X
B	METAL LEG		1X

(Page 2 of 4)

PREPARATION

Before beginning assembly of product, make sure all parts are present. Compare parts with package contents list and hardware contents list. If any part is missing or damaged, do not attempt to assemble the product. Estimated Assembly Time: 10 minutes.

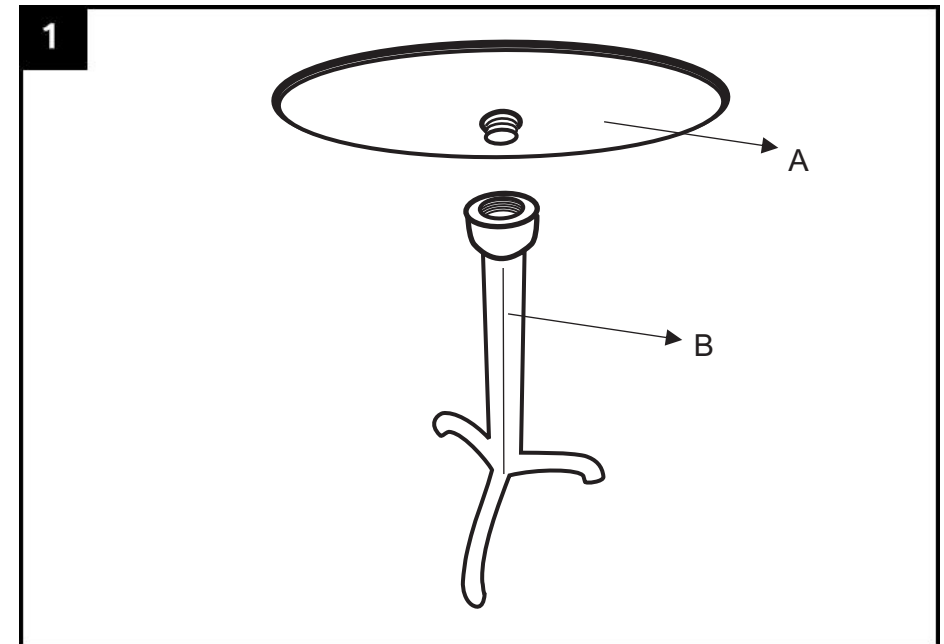

Step 1

The top (A) put on the hole of leg (B)

(Page 3 of 4)

Product Dimensions : 20.25" X 20.25" X 16"

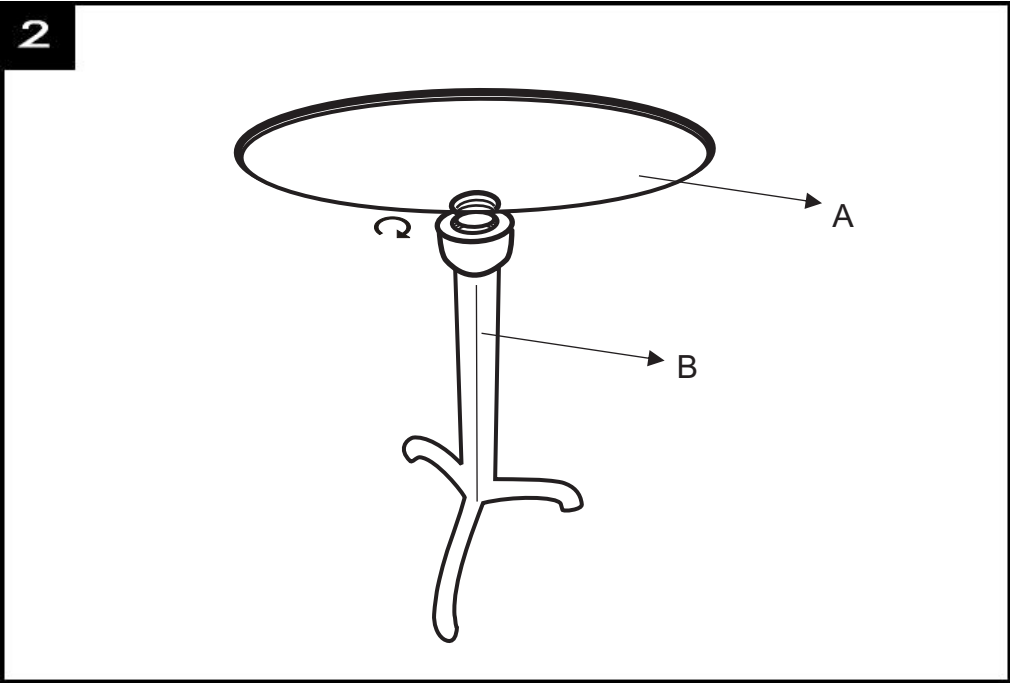

Step 2
Rotate clockwise.

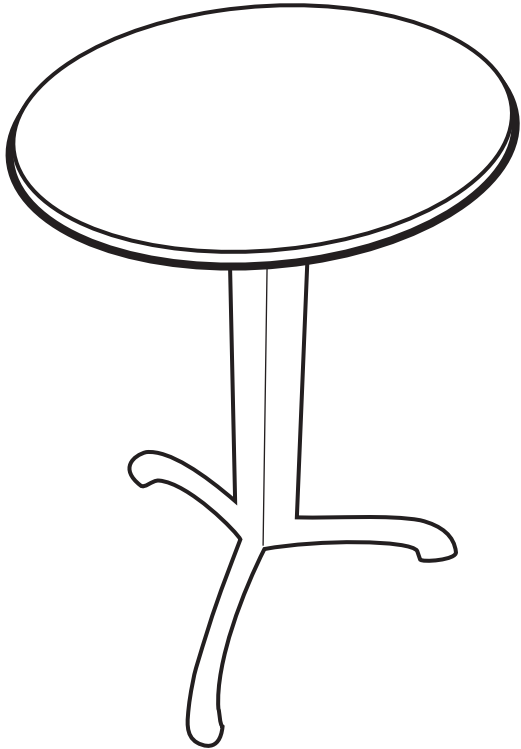

CARE AND MAINTENANCE

Do not use acids or alkaline cleaning agents. Sharp objects will damage and scratch the surface. Wipe the surface with a soft, damp cloth.



NOTICE

* Please make sure that you have all parts indicated before you begin assembly of this item

* This item should be assembled on a soft surface to prevent scratching the finish during assembly

* This item may require periodic tightening

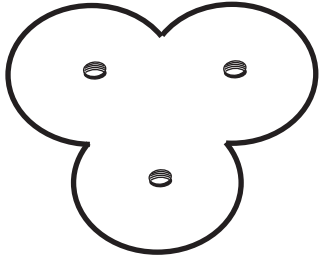
Part List and Hardware List

	DESCRIPTION	PICTURE	QUANTITY
I	TABLE TOP (A)		1X
II	METAL LEGS (B)		3X

(Page 2 of 4)

PREPARATION

Before beginning assembly of product, make sure all parts are present.

Compare parts with package contents list and hardware contents list.

If any part is missing or damaged, do not attempt to assemble the product.

Estimated Assembly Time: 10 minutes.

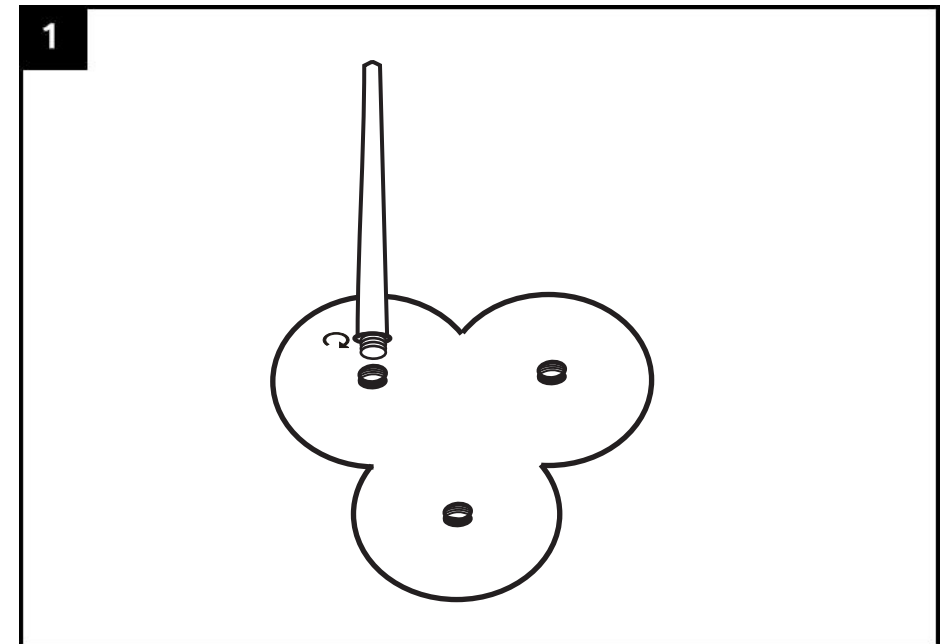

Step 1

Put a leg (B) on the hole of table top bottom (A) and rotate clockwise.

(Page 3 of 4)

Product Dimensions : 16" X 16" X 18.75"

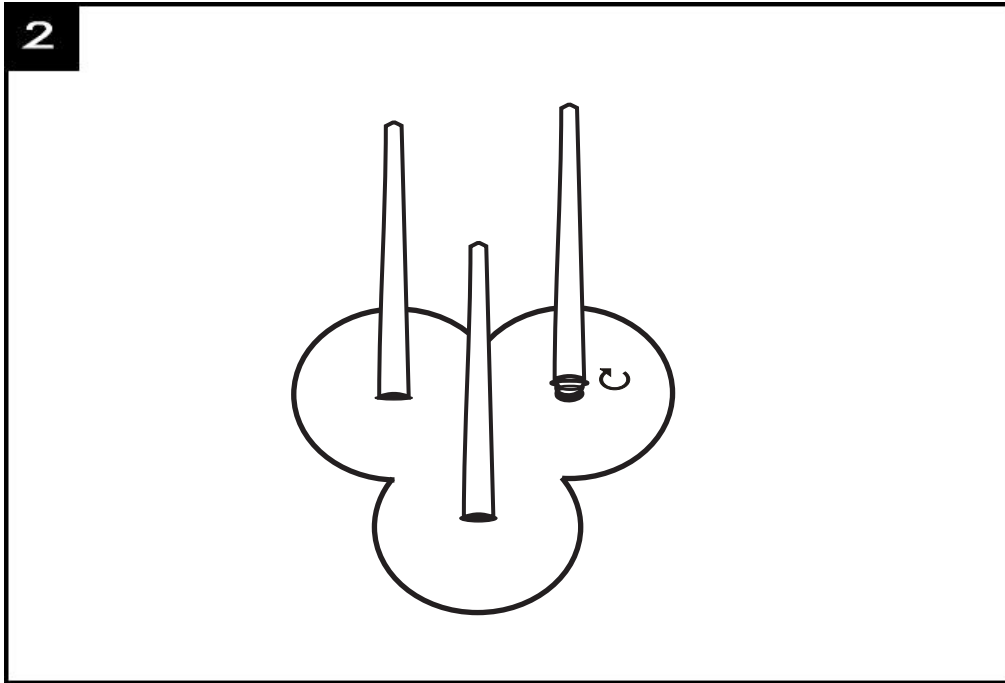

Step 2

Accordingly first leg please place both legs on the hole of table top Bottom & rotate clockwise.

