

Assembly Instructions

Sun Room 8' - Clear Glazing

 **Snow Load**
75 kg/m²
15.4 lbs/ft²

 **Wind Resistant**
90 km/hr
56 ml/hr

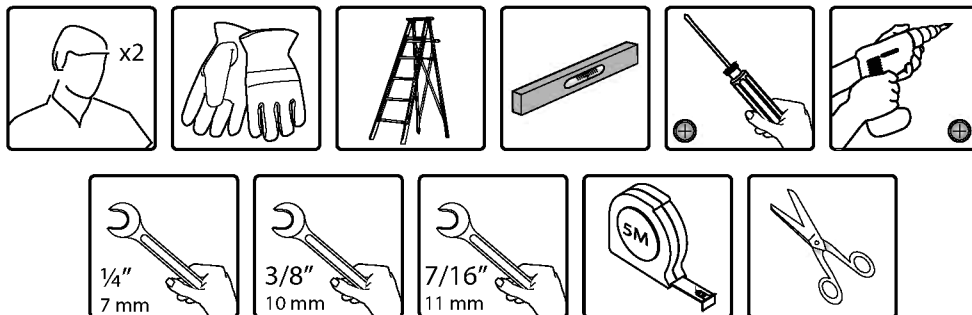
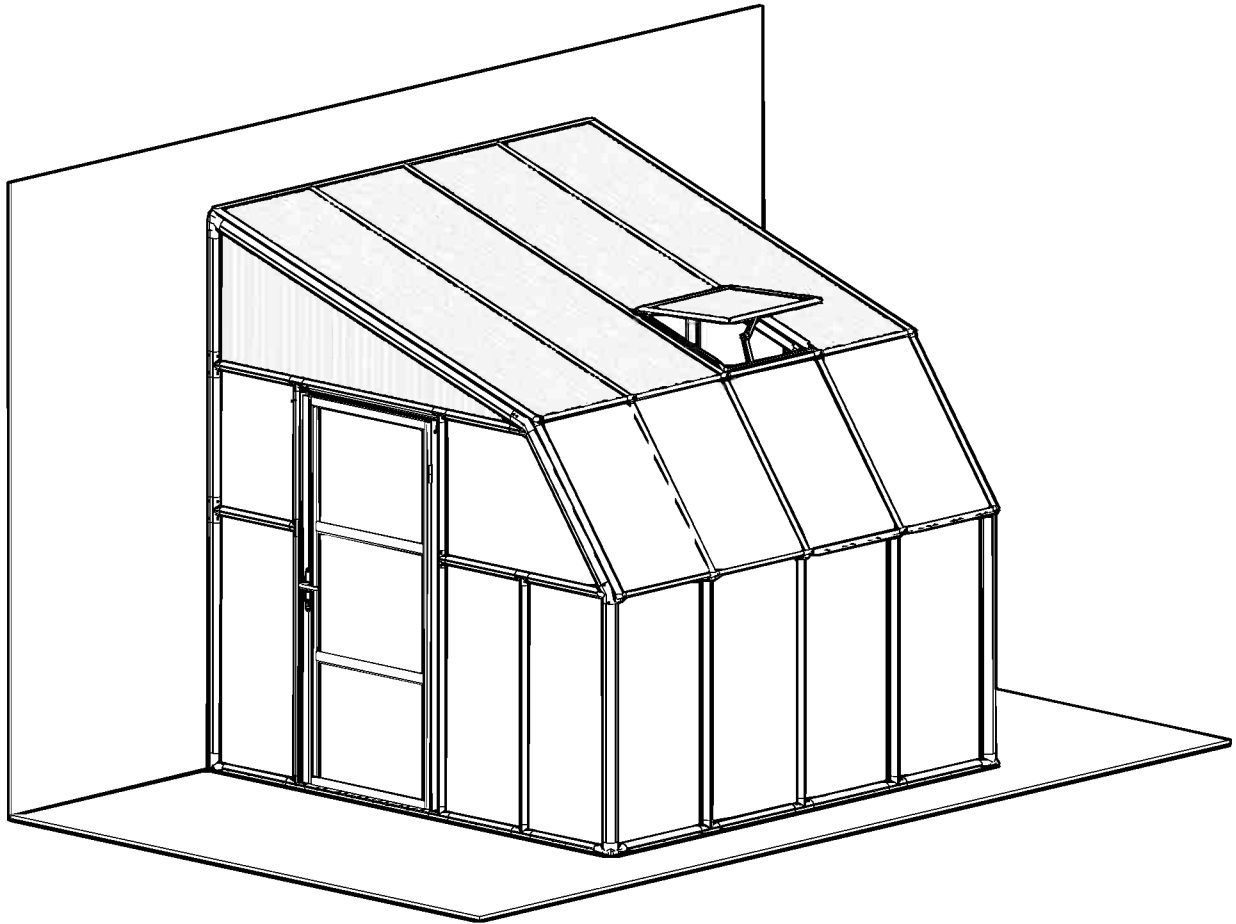

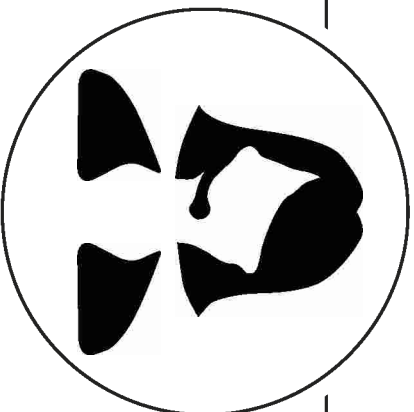

After Sale Service



customer.service@palram.com



USA ----- 877-627-8476

England ----- 01302-380775



customer.serviceUK@palram.com

France ----- 0169-791-094



customer.serviceFR@palram.com

Germany ----- 0180-522-8778



customer.serviceDE@palram.com

International -----+972 4-848-6816

IMPORTANT

Please read these instructions carefully before you start to assemble this SunRoom 8'.
Keep these instructions in a safe place for future reference.

GENERAL

- RION is not responsible for the misuse of tools or parts
- All opaque panels with the stamped words THIS SIDE OUT indicates the outside to create a full UV protection. Remove plastic sticker as panels are locked in place.
- All clear panels are protected by plastic film on both sides and don't have specific direction to install. Remove the plastic film before installation.
- The quantity of parts that are required for the extension, depends on the number packages purchased.
- Door can be assembled on the left or right hand side; in addition you can determine door direction opening.
- Specific screws and bolts must be purchased based on the surface (wall and ground) that the SunRoom 8' will be connected to.

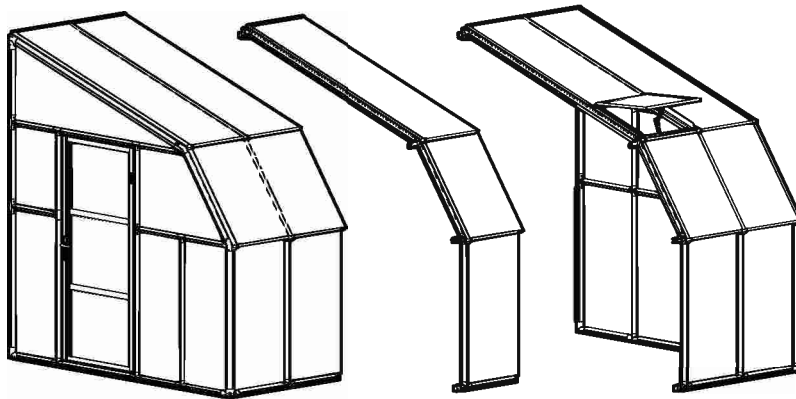

Front 4'

Middle 2'

Back 4'

Greenhouse Sizes	Pack Qty (Front 4')	Pack Qty (Middle 2')	Pack Qty (Back 4')
8' x 8'	1	x	1
8' x 10'	1	1	1
8' x 12'	1	2	1
8' x 14'	1	3	1
8' x 16'	1	4	1
8' x 18'	1	5	1
8' x 20'	1	6	1

SAFETY ADVICE

- RION is not responsible for the misuse of tools or parts.
- It is of utmost importance to assemble all of the parts according to the directions. Please follow them closely and do not skip any of the steps.
- We strongly recommend using working gloves during assembly.
- If using a step ladder or power tools ensure that you follow the manufacturer's safety advice.
- If local building codes require permits or licenses make sure that they are acquired before beginning.
- Your SunRoom 8' should be secured to the prepared foundation using the recommended hardware.
- Do not attempt to assemble the SunRoom 8' in windy or wet conditions.
- Dispose of all plastic bags. Please keep them out of reach of small children.
- Keep children away from the assembly area.
- Do not lean against or push the SunRoom 8' during construction.
- Do not attempt to assemble this SunRoom 8' if you are tired, have taken drugs or alcohol or if you are prone to dizzy spells.
- When your SunRoom 8' is fully assembled examine it for sharp edges and trim with a razor knife if necessary.
- If you live in a hot climate area, where outside temperatures exceed 46° C (115° F) under the sun or 36° C (99° F) in the shade, this may cause the temperature inside the SunRoom 8' to exceed 55° C (131° F). Such conditions may harm your plants and will damage the SunRoom 8' by warping the structural profiles. In order to prevent damage:
 - Ensure good ventilation during hot days.
 - Make sure that the temperature inside the SunRoom 8' never exceeds 55° C (131° F) by providing a shading screen, such as the Shade Net (available as an accessories option).

Note: RION is not responsible for any damage due to high temperatures.

* Always close roof vent in high winds.

REQUIRED TOOLS

- GT1 - Special tool to connect pins through lined up holes. Pin Tool fix and lock profiles in place.
- To assemble this product you will need the following tools (these items are not supplied).

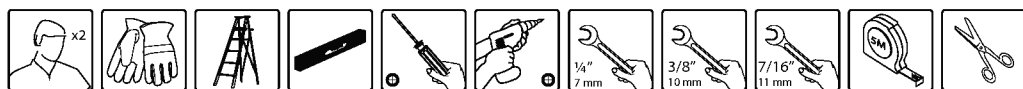

BEFORE ASSEMBLY

- RION is not responsible for the misuse of tools or parts.
- Selecting a site - the SunRoom 8' must be, positioned and fixed on a flat level surface.
- Sort the parts and check according to the contents parts list. Do not begin assembly if any other parts are missing.
- If you prepare a concrete foundation do not excavate and pour concrete in frozen ground.
- We recommend that you place your SunRoom 8' in a spot where it will receive direct sunlight and will be protected from the wind as much as possible. The door should not face prevailing winds.

DURING ASSEMBLY

Step 1: Determine which side to place the door. The decision will affect the upcoming steps.

Steps 1, 3: Arrange all 2D connectors with the stamped word "OUT" facing out of the SunRoom 8'.

Step 4:

- Make sure that the frame is perfectly straightened by measuring and verifying that they leveled.
- Make sure that the frame is leveled and anchor it to the ground with screw / screw + dibble / spike (not supplied) in accordance with the selected surface.
- The wall to which you are securing your SunRoom 8' must be 90° to the foundation.

Step 17:

- Make sure that the frame is perfectly straightened by measuring and verifying that they leveled.
- Make sure that the frame is leveled and anchor it to the wall with screw / screw + dibble / spike (not supplied excluding part # BC1) in accordance with the selected surface.
- The wall to which you are securing your SunRoom onto must be 90° to the foundation.

Reinforcement Arch Profiles

Steps 18-23:

- Ensure that all the metal profiles are inserted inside the plastic profiles.
- Repeat each step based on your SunRoom 8' size and the number of arch profiles needed to be assembled as illustrated. (These assembly instructions refer only to SunRoom 8'x8' and 8'x10').

Step 27: Make sure that the profiles are perfectly straightened by measuring and verifying that they are leveled.

Anchor the **Part 7937** to the ground with screw / screw + dibble / spike (not supplied) according to the selected surface.

Step 28: Repeat **Steps 24-27** according to the amount of modules purchased.

Step 30: Repeat and refer to **Step 4**.

Steps 39-40: Repeat and refer to **Step 17**.

Step 41: Seal the SunRoom 8' edges with Silicon Sealant.

Step 57: Insert the rubber strip (**Part GF**) from the outside of the SunRoom 8'. Cut the remaining edges.

Step 64: Insert the rubber strip (**Part 7869**) from the outside of the SunRoom 8'. During this step, turn the door in order to insert the rubber strip correctly.

Step 66: Determines door direction. The door can be installed and open either as a left or right hand door.

Step 69: Adjust the hinges height in accordance with the upper post and lower ramp of the door aperture, as specified in level C.

Step 73: The door can be installed either as a right or left hand door. choose one of the two options depicted.

ATTENTION:

 When encountering the information icon, please refer to therelevant assembly step for additional comments and assistance.

 This icon indicates that the installer should be inside the product.

IMPORTANT

Veillez lire les instructions suivantes attentivement avant de commencer à assembler cette véranda 8'. Gardez ces instructions dans un endroit sécurisé pour référence future.

GÉNÉRAL

- RION n'est pas responsable de la mauvaise utilisation d'outils ou de composants
- Tous les panneaux opaques avec la mention CE CÔTÉ VERS L'EXTÉRIEUR indiquent l'extérieur pour créer une protection UV intégrale. Retirez les stickers en plastique alors que les panneaux sont verrouillés en place.
- Tous les panneaux transparents sont protégés par un film plastique sur les deux côtés et n'ont pas de direction spécifique d'installation.
- La quantité de composants requis pour l'extension dépend du nombre de packs achetés.
- La porte peut être assemblée du côté droit ou gauche ; vous pouvez également déterminer le sens d'ouverture de la porte.
- Des vis et des boulons spécifiques doivent être achetés en fonction de la surface (mur et sol) à laquelle la véranda 8' sera connectée.

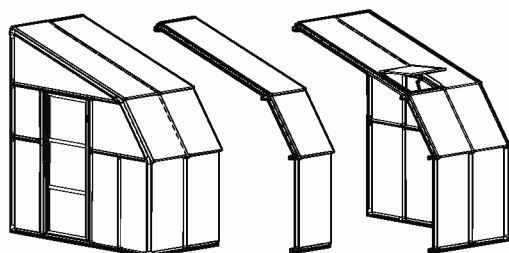

Avant 4' Milieu 2' Arrière 4'

Dimensions des serres de jardin	Qté packs (avant 4')	Qté packs (milieu 2')	Qté packs (Arrière 4')
8' x 8'	1	x	1
8' x 10'	1	1	1
8' x 12'	1	2	1
8' x 14'	1	3	1
8' x 16'	1	4	1
8' x 18'	1	5	1
8' x 20'	1	6	1

CONSEILS DE SÉCURITÉ

- RION est pas responsable de la mauvaise utilisation d'outils ou de pièces.
- Il est de la plus haute importance d'assembler toutes les pièces en suivant les instructions. Veillez suivre les instructions de près et ne pas sauter de l'une des étapes.
- Nous vous recommandons fortement d'utiliser des gants de travail lors de l'assemblage.
- Si vous utilisez un escabeau ou des outils électriques, suivez les conseils de sécurité du fabricant.
- Si les codes de construction locaux exigent des permis ou des licences, obtenez-les avant de commencer.
- Votre véranda 8' devrait être fixée à la fondation préparée en utilisant le matériel recommandé.
- Ne tentez pas d'assembler la véranda 8' dans des conditions venteuses ou humides.
- Débarrassez-vous de tous les sacs en plastique. Veillez les garder hors de portée des jeunes enfants.
- Gardez les enfants loin de la zone d'assemblage.
- Ne vous appuyez pas contre la véranda 8' et ne la poussez pas en cours de construction.
- Ne tentez pas d'assembler la véranda 8' si vous êtes fatigué, si vous avez consommé de la drogue ou de l'alcool ou si vous êtes sujet à des étourdissements..
- Lorsque votre véranda 8' est complètement montée, examinez-la pour détecter les bords tranchants et taillez-les avec une lame de rasoir si nécessaire.
- Si vous habitez dans une zone de climat chaud, où les températures extérieures dépassent 46° C (115° F) sous le soleil ou 36° C (99° F) à l'ombre, ceci peut conduire à l'augmentation de la température à l'intérieur de la véranda 8' pour dépasser 55° C (131° F). Ces conditions peuvent nuire à vos plantes et endommager la véranda 8' en déformant les profils structurels. Afin de prévenir les dommages:
 - Veillez à assurer une bonne ventilation pendant les journées chaudes.
 - Assurez-vous que la température à l'intérieur de la véranda 8' ne dépasse jamais 55° C (131° F) en installant des stores, comme le filet d'ombrage (disponible en option dans les accessoires).

Remarque: RION est pas responsable de tout dommage dû à des températures élevées.

* Toujours fermer l'ouverture du toit en cas de vents violents.

OUTILS NÉCESSAIRES

- GT1 - Outil spécial pour raccorder les broches aux trous alignés. Fixe et verrouille les profils en place.
- Pour assembler ce produit, vous aurez besoin des outils suivants (ces éléments ne sont pas fournis).



ATTENTION:

 Lorsque vous rencontrez l'icône d'information, veuillez vous référer à l'étape d'assemblage correspondante pour plus de commentaires et d'assistance.

 Cette icône indique que l'installateur doit être à l'intérieur du produit.

AVANT D'ASSEMBLER

- RION est pas responsable de la mauvaise utilisation d'outils ou de pièces.
- Sélectionnez un emplacement - La véranda 8' doit être positionnée et fixée sur une surface plane.
- Triez les pièces et vérifiez leur nombre selon le contenu de la liste des pièces. Ne pas commencer l'assemblage si d'autres pièces sont manquantes.
- Si vous préparez une fondation en béton, ne creusez pas et ne coulez pas le béton dans le sol gelé.
- Nous vous recommandons de placer votre véranda 8' dans un endroit où elle pourra recevoir la lumière solaire directe et sera protégée du vent autant que possible. La porte ne doit pas faire face au vent

LORS DE L'ASSEMBLAGE

Étape 1: Déterminez de quel côté vous allez placer la porte. La décision aura des conséquences sur les étapes à venir.

Étapes 1, 3: Disposez tous les connecteurs 2D avec la mention "**EXTÉRIEUR**" vers l'extérieur de la véranda 8'.

Étape 4:

- Assurez-vous que le cadre est parfaitement redressé en mesurant et en vérifiant qu'il est nivelé.
- Assurez-vous que le cadre est nivelé et ancrez-le au sol avec une vis / vis + plantoir / pointe (non fournis) conformément à la surface sélectionnée.
- Le mur sur lequel vous sécurisez votre véranda 8' doit être à 90° de la fondation.

Étape 17:

- Assurez-vous que le cadre est parfaitement redressé en mesurant et en vérifiant qu'il est nivelé.
- Assurez-vous que le cadre est nivelé et ancrez-le au mur avec une vis / vis + plantoir / pointe (non fournis à l'exception de la pièce # BC1) conformément à la surface sélectionnée.
- Le mur sur lequel vous sécurisez votre véranda doit être à 90° de la fondation.

Renforcement profils d'arc

Étapes 18-23:

- Veillez à ce que tous les profils métalliques soient insérés à l'intérieur des profils en plastique.
- Répétez chaque étape en fonction de la dimension de votre véranda 8' et du nombre de profils en arc devant être assemblés comme illustré. (Ces instructions de montage se réfèrent uniquement aux véranda 8'x8' et 8'x10').

Étape 27: Assurez-vous que les profils sont parfaitement redressés en mesurant et en vérifiant qu'ils sont nivelés.

Ancrez la pièce **7937** au sol avec une vis / vis + plantoir / pointe (non fourni) en fonction de la surface sélectionnée.

Étape 28: Répétez les étapes **24 à 27** en fonction de la quantité de modules achetés.

Étape 30: Répétez et reportez-vous à l'étape **4**.

Étapes 39-40: Répétez et reportez-vous à l'étape **17**.

Étape 41: Scellez les bords de la véranda 8' avec du silicone.

Étape 57: Insérez la bande de caoutchouc (**Pièce GF**) de l'extérieur de la véranda 8'. Coupez les bords restants.

Étape 64: Insérez la bande de caoutchouc (**Pièce 7869**) de l'extérieur de la véranda 8'. Au cours de cette étape, faites tourner la porte afin d'insérer correctement la bande de caoutchouc.

Étape 66: Déterminez la direction de la porte. La porte peut être installée et ouverte à gauche ou à droite.

Étape 69: Réglez la hauteur des charnières en conformité avec le poste supérieur et la rampe inférieure de l'ouverture de la porte, comme spécifié dans le niveau C.

Étape 73: La porte peut être installée de manière à s'ouvrir sur la droite ou sur la gauche. Ces instructions montrent un montage correct de la porte. Choisissez l'une des deux options représentées.

DE

WICHTIG

Bitte lesen Sie diese Anleitung sorgfältig durch, bevor Sie mit dem Zusammenbau des SunRoom 8' beginnen. Bewahren Sie diese Anleitung zum späteren Nachschlagen sorgfältig auf.

ALLGEMEIN

- RION haftet nicht für eine fehlerhafte Handhabung von Bauteilen oder Werkzeugen.
- Die Aufschrift THIS SIDE OUT auf lichtundurchlässigen Bauteilen markiert die Außenseite für einen vollständigen UV-Schutz.
- Entfernen Sie die Aufkleber, sobald die Bauteile montiert sind.
- Alle durchsichtigen Bauteile sind beidseitig mit einer Schutzfolie aus Kunststoff versehen und erfordern keine bestimmte Einbaurichtung. Entfernen Sie die Folie vor der Montage.
- Die Anzahl der für die Erweiterung nötigen Bauteile hängt von der Anzahl der erworbenen Einheiten ab.
- Die Tür kann sowohl rechts- als auch linksöffnend angebracht werden. Darüber hinaus können Sie auch die Öffnungsrichtung bestimmen.
- Geeignete Schrauben und Bolzen müssen abhängig vom verwendeten Untergrund (Wand und Boden), auf dem der SunRoom 8' montiert wird, separat erworben werden.

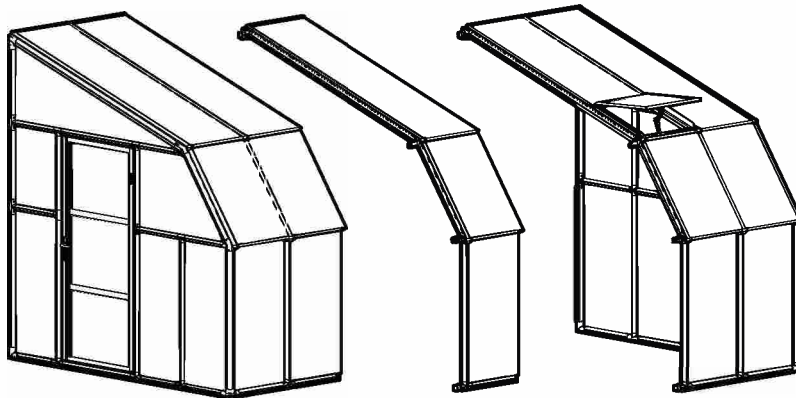

Vorderseite 4 ft.
(122 cm)

Mittelteil 2 ft.
(61 cm)

Rückseite 4 ft.
(122 cm)

Gewächshaus Abmessungen	Liefermenge (Vorderseite 4 ft.)	Liefermenge (Mittelteil 2 ft.)	Liefermenge (Rückseite 4 ft.)
8' x 8'	1	x	1
8' x 10'	1	1	1
8' x 12'	1	2	1
8' x 14'	1	3	1
8' x 16'	1	4	1
8' x 18'	1	5	1
8' x 20'	1	6	1

SICHERHEITSHINWEISE

- RION haftet nicht für eine fehlerhafte Handhabung von Bauteilen oder Werkzeugen.
- Es ist von größter Wichtigkeit, dass alle Teile gemäß der Anleitung zusammengesetzt werden. Folgen Sie den Anweisungen genau, und lassen Sie keine Schritte aus.
- Wir empfehlen dringend, für die Montage Arbeitshandschuhe zu verwenden.
- Sollten Sie eine Stehleiter oder elektrisch betriebene Werkzeuge verwenden, stellen Sie sicher, dass Sie die Sicherheitshinweise der jeweiligen befolgen.
- Sollten örtliche Bauvorschriften Genehmigungen oder Bewilligungen vorschreiben, stellen Sie sicher, dass diese vor Beginn der Montage vorliegen.
- Ihr SunRoom 8' sollte unter Verwendung der empfohlenen Materialien sicher mit dem Untergrund verbunden werden.
- Versuchen Sie nicht, den SunRoom 8' bei windigen oder feuchten Witterungsbedingungen aufzubauen.
- Entsorgen Sie sämtliche Kunststofftüten. Halten Sie sie außerhalb der Reichweite von Kindern.
- Halten Sie Kinder vom Montagebereich fern.
- Sie sollten den SunRoom 8' während der Montage weder drücken noch sich dagegen lehnen.
- Versuchen Sie nicht den SunRoom 8' aufzubauen, wenn Sie sich müde fühlen, unter Medikamenten- oder Alkoholeinfluss stehen oder wenn Sie zu Schwindelanfällen neigen.

- Sobald Ihr SunRoom 8' vollständig aufgebaut ist, untersuchen Sie ihn auf scharfe Kanten, und entfernen Sie diese, falls nötig, mit einer Rasierklinge.
- Falls Sie in sehr heißen klimatischen Bedingungen leben, in denen die Außentemperatur 46 °C (115 °F) in der Sonne und 36 °C (99 °F) im Schatten übersteigt, kann das zu Temperaturen im Innern des SunRoom 8' von über 55 °C (131 °F) führen. Solche Temperaturen können Ihren Pflanzen schaden und den SunRoom durch Verformung der Bauteile beschädigen. Um Schaden vorzubeugen:
 - Sorgen Sie an heißen Tagen für ausreichende Lüftung.
 - Stellen Sie sicher, dass die Temperatur im SunRoom 8' 55 °C (131 °F) nie übersteigt, indem Sie einen Sonnenschutz wie beispielsweise das Shade Net (als Zubehör verfügbar) einsetzen.

Hinweis: RION haftet nicht für durch hohe Temperaturen versuchte Schäden.

*Halten Sie die Dachlüftungsklappen bei starkem Wind stets geschlossen.

ERFORDERLICHES WERKZEUG

- GT1 - Spezialwerkzeug zu Befestigung von Stiften in Lochreihen. Stiftwerkzeug zum Anbringen und zur Montage von Profilen.
- Zur Montage dieses Produktes benötigen Sie folgende Werkzeuge (nicht im Lieferumfang enthalten).

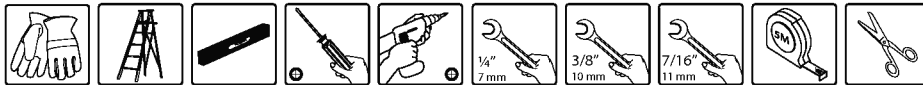

ACHTUNG:

 Wenn Sie auf das Informationssymbol stoßen, gehen Sie bitte zum angegebenen Montageschritt, um alle nötigen Hinweise und Informationen zu erhalten.

 Dieses Symbol signalisiert, dass die montierende Person sich innerhalb des Produktes befinden sollte.

VOR DER MONTAGE

- RION haftet nicht für eine fehlerhafte Handhabung von Bauteilen oder Werkzeugen.
- Auswahl des Untergrunds – der SunRoom 8' muss auf einer ebenen und geraden Fläche aufgestellt und befestigt werden.
- Sortieren und überprüfen Sie die Teile anhand der Packliste. Beginnen Sie nicht mit der Montage, falls Teile fehlen.
- Falls Sie ein Betonfundament vorbereiten wollen, tun Sie dies nicht bei gefrorenem Boden.
- Wie empfehlen Ihnen, den SunRoom 8' an einem Ort aufzustellen, an dem er viel direktes Sonnenlicht erhält und möglichst vor Wind geschützt ist. Die Tür sollte nicht in Richtung der vorherrschenden Windrichtung aufgebaut werden.

WÄHRENDE DER MONTAGE

Schritt 1: Bestimmen Sie, auf welcher Seite Sie die Tür anbringen wollen. Diese Entscheidung beeinflusst die folgenden Schritte.

Schritte 1, 3: Bringen Sie alle 2D-Verbindungen mit der Aufschrift „OUT“ so an, dass sie aus dem SunRoom 8' hinaus zeigen.

Schritt 4:

- Stellen Sie sicher, dass der Rahmen komplett gerade ist, indem Sie die Ausrichtung mit einer Wasserwaage überprüfen.
- Wenn Sie sichergestellt haben, dass der Rahmen gerade steht, verankern Sie ihn mit einer Schraube / Schraube und Pflanzstock / Nagel (bis auf Teil BC1 nicht im Lieferumfang enthalten) passend zum gewählten Untergrund.
- Die Wand, an der Sie Ihren SunRoom 8' befestigen wollen, muss in einem Winkel von 90° zum Fundament stehen.

Verstärkungsbogenprofile

Schritte 18-23:

- Stellen Sie sicher, dass alle Metallprofile in die Plastikprofile eingezogen werden.
- Wiederholen Sie jeden Schritt gemäß der Abbildung und entsprechend der Größe Ihres SunRoom 8' und der Anzahl der zur Montage benötigten Bogenprofile.
(Die vorliegende Montageanleitung bezieht sich nur auf den SunRoom 8ft. * 8ft. (244 cm * 122 cm) und 8ft. * 10ft. (244 cm * 305 cm).

Schritt 27: Stellen Sie sicher, dass alle Profile komplett gerade sind, indem Sie die Ausrichtung mit einer Wasserwaage überprüfen. Verankern Sie Bauteil **7937** mit einer Schraube / Schraube und Pflanzstock / Nagel (nicht im Lieferumfang enthalten) passend zum gewählten Untergrund.

Schritt 28: Wiederholen Sie die **Schritte 24-27** entsprechend der Anzahl der erworbenen Einheiten.

Schritt 30: Schritt wiederholen und **Schritt 4** konsultieren.

Schritt 39-40: Schritt wiederholen und **Schritt 17** konsultieren.

Schritt 41: Dichten Sie die Kanten des SunRoom 8' mit Silikondichtmasse ab.

Schritt 57: Ziehen Sie den Gummistreifen (**Teil GF**) von außen in den SunRoom 8' ein. Schneiden Sie überstehenden Gummi ab.

Schritt 64: Ziehen Sie den Gummistreifen (**Teil 7869**) von außen in den SunRoom 8' ein. In diesem Schritt müssen Sie die Tür bewegen, um den Gummistreifen korrekt einführen zu können.

Schritt 66: Bestimmt die Öffnungsrichtung der Tür. Die Tür kann sowohl rechts- als auch linksöffnend installiert werden.

Schritt 69: Passen Sie die Befestigungshöhe der Scharniere – wie in Teil C beschrieben – entsprechend dem oberen Pfostenteil und der Rampe der Türöffnung an.

Schritt 73: Die Tür kann mit rechtem oder linken Türanschlag eingebaut werden. In dieser Anleitung wird ein Türeingebau mit rechtem Türanschlag dargestellt. Wählen Sie eine der zwei dargestellten Optionen.

IMPORTANTE

Por favor, lea estas instrucciones atentamente antes de empezar a montar este SunRoom 8'.
 Guarde estas instrucciones en un lugar seguro para que pueda referirse a ellas en el futuro.

GENERAL

- RION no es responsable por el mal uso de las herramientas o las piezas.
- Todos los paneles opacos estampados con las palabras LADO EXTERIOR (THIS SIDE OUT) indican la parte exterior para que se cree una protección UV completa. Quite las pegatinas de plástico cuando haya enganchado los paneles en su sitio.
- Todos los paneles transparentes están protegidos por una película de plástico en ambos lados y no tienen una dirección específica a la hora de montarse. Quite el plástico antes de instalarlo.
- La cantidad de piezas requeridas para la ampliación dependerá del número de paquetes que haya comprado.
- Las puertas se pueden montar por el lado derecho o el izquierdo; además puede determinar la dirección en la que quiere que se abran.
- Hay que comprar tornillos y tuercas específicos según la superficie (pared y terreno) al que se sujetará la SunRoom 8'.

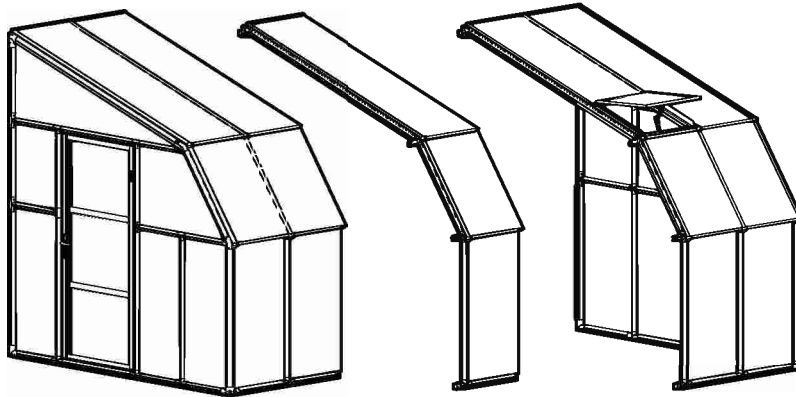

Frontal 4'

Medio 2'

Trasero 4'

Invernadero Tamaños	Cantidad por paquete (Frontal 4')	Cantidad por paquete (Medio 2')	Cantidad por paquete (Trasero 4')
8' x 8'	1	x	1
8' x 10'	1	1	1
8' x 12'	1	2	1
8' x 14'	1	3	1
8' x 16'	1	4	1
8' x 18'	1	5	1
8' x 20'	1	6	1

CONSEJOS DE SEGURIDAD

- RION no es responsable por el mal uso de las herramientas o las piezas.
- Es de la mayor importancia que monte todas las piezas según las directrices. Por favor, sígalas atentamente y no se salte ninguno de los pasos.
- Le recordamos encarecidamente que use guantes para el trabajo durante el montaje.
- Si utiliza una escalera de peldaños o herramientas eléctricas, asegúrese de seguir las instrucciones de seguridad del fabricante.
- Si las normativas para construir localmente requieren permisos o licencias, asegúrese de obtenerlos antes de empezar.
- Su SunRoom 8' debe sujetarse bien al fundamento que ya ha preparado mediante las herramientas recomendadas.
- No intente montar el SunRoom 8' cuando el tiempo sea ventoso o llueva.
- Deshágase de todas las bolsas de plástico. Por favor, manténgalas lejos del alcance de los niños pequeños.
- Mantenga a los niños lejos de la zona de montaje.
- No se apoye o empuje el SunRoom 8' durante la construcción.
- No intente montar este SunRoom 8' si está cansado, ha tomado drogas o alcohol o tiene tendencia a sufrir mareos.
- Cuando su SunRoom 8' esté totalmente montada, examine si hay algún borde afilado y recórtelo con una cuchilla si fuese necesario
- Si vive en una zona de clima cálido, en la que la temperatura externa supere los 46° C (115° F) bajo el sol o los 36° C (99° F) en la sombra, esto puede hacer que la temperatura dentro del SunRoom 8' supere los 55° C (131° F). Sus plantas se pueden dañar bajo esas condiciones y dañará el SunRoom 8' al deformar los contornos de la estructura. Para evitar el daño:
 - Durante los días cálidos, asegúrese de que haya una buena ventilación.
 - Asegúrese de que la temperatura dentro del SunRoom 8' no sobrepase nunca los 55° C (131° F) mediante una pantalla que dé sombra, como la Shade Net (disponible como un accesorio complementario).

Nota: RION no es responsable de ningún daño causado por las elevadas temperaturas.

* Siempre que haya vientos fuertes cierre la ventilación del techo.

HERRAMIENTAS NECESARIAS

- GT1: una herramienta especial para conectar las clavijas en los agujeros conectados. La herramienta para clavijas sujeta y engancha los contornos en su sitio
- Para montar este producto necesitará las herramientas siguientes (las herramientas no se suministran).



ANTES DEL MONTAJE

- RION no es responsable por el mal uso de las herramientas o las piezas.
- Elección del sitio. El SunRoom 8' debe colocarse y engancharse en una superficie que esté plana.
- Clasifique las piezas y compruébelas con la lista de las piezas del contenido. No empiece el montaje si le falta alguna de las piezas.
- Si va a preparar un fundamento de hormigón, no excave ni vierta el hormigón en un terreno congelado.
- Le recomendamos que coloque el SunRoom 8' en un lugar donde reciba la luz solar directa y que esté lo más protegida del viento posible. La puerta no debe mirar hacia los vientos predominantes.

DURANTE EL MONTAJE

Paso 1: Determine en qué lado quiere poner la puerta. La decisión afectará al resto de los pasos.

Pasos 1, 3: Coloque todos los conectores 2D que tienen la palabra EXTERIOR ("OUT") mirando hacia afuera en el SunRoom 8'.

Paso 4:

- Asegúrese de que el marco quede perfectamente derecho midiendo y verificando que estén nivelados.
- Asegúrese de que el marco esté nivelado y sujételo al suelo con el tornillo/ el tornillo + plantador/ el pico (no se suministra), depende de la superficie seleccionada.
- La pared a la que va a asegurar la SunRoom 8' debe tener un ángulo de 90° con los cimientos.

Paso 17:

- Asegúrese de que el marco esté perfectamente derecho, mídalo y verifique que están nivelados.
- Asegúrese de que el marco esté nivelado y anclado en la pared con el tornillo/ el tornillo + plantador/ el pico (no se suministra la pieza excluyente n.º BC1) de acuerdo a la superficie seleccionada.
- La pared con la que está anclando el SunRoom debe tener un ángulo de 90° con los cimientos.

Contornos de refuerzo en arco

Pasos 18-23:

- Asegúrese de que todos los contornos metálicos estén dentro de los contornos plásticos.
- Repita cada paso dependiendo del tamaño de su SunRoom 8' y el número de contornos en arco necesarios para montar como se ilustra. (Estas instrucciones de montaje se refieren solo a la SunRoom 2,43 m x 2,43 m y 2,43 m x 3 m - 8'x8' y 8'x10').

Paso 27: Asegúrese de que los contornos estén perfectamente derechos midiendo y verificando que estén nivelados.

Ancle la pieza **7937** en tierra con el tornillo/ el tornillo + plantador/ el pico (no se suministra), de acuerdo a la superficie seleccionada.

Paso 28: Repita los **pasos 24-27** de acuerdo a la cantidad de módulos que haya comprado.

Paso 30: Repita y refiérase al **paso 4**.

Pasos 39-40: Repita y refiérase al **paso 17**.

Paso 41: Selle los bordes del SunRoom 8' con un sellador de silicona.

Paso 57: Inserte la tira de goma (**Pieza GF**) desde fuera del SunRoom 8'. Corte los bordes que sobren.

Paso 64: Inserte la tira de goma (**Pieza 7869**) desde fuera del SunRoom 8'. Durante este paso, gire la puerta para insertar correctamente la tira de goma.

Paso 66: Determina la dirección de la puerta. La puerta puede estar instalada y abierta, ya sea hacia la mano izquierda o la derecha.

Paso 69: Ajuste la altura de los goznes de acuerdo al poste superior y a la rampa inferior de la apertura de la puerta, como se especifica en el nivel C.

Paso 73: La puerta puede instalarse para abrirse tanto a la derecha como a la izquierda. Estas instrucciones muestran una instalación de puerta que abre a la derecha. elige una de las dos opciones mostradas.

ATENCIÓN:

Cuando se encuentre con el icono de información, por favor, remítase al paso de montaje pertinente para ver los comentarios adicionales y para buscar ayuda.

Este icono indica que el instalador debe estar dentro del producto.

DA

VIGTIGT

Læs venligst vejledningen omhyggeligt inden du påbegynder monteringen af denne 8 fods havestue.
Opbevar vejledningen et sikkert sted for fremtidig reference.

GENERELT

- RION er ikke ansvarlig for misbrug af værktøj eller dele
- Alle uigennemsigtige paneler med de påstemplede ord DENNE SIDE UD, viser ydersiden for at opnå fuld UV-beskyttelse. Fjern plastikmærkaterne når paneler er på plads.
- Alle klare paneler er beskyttet af plastikfilm på begge sider, og skal ikke monteres i nogen specifik retning. Fjern plastikfilmen inden montering.
- Antallet af dele som er nødvendige til udvidelsen, afhænger af hvor mange pakker der er købt.
- Døre kan samles til venstre eller højre side; derudover kan du også bestemme hvilken vej døren åbnes.
- Specifikke skruer og bolte skal indkøbes afhængigt af den overflade (væg og underlag), hvortil den 8 fods Havestue forbindes.

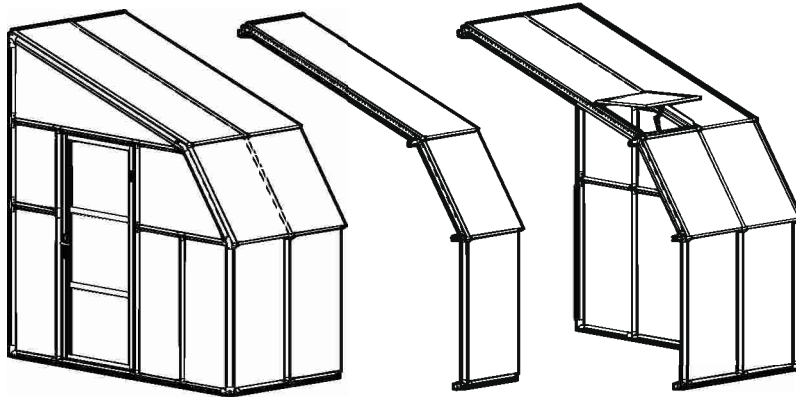

Forside 4' (120 cm)

Midt 2' (60 cm)

Bagside (120 cm)

Drivhus Størrelser	Pakke antal Forside 4' (120 cm)	Pakke antal Midt 2' (60 cm)	Pakke antal Bagside (120 cm)
8' x 8'	1	-	1
8' x 10'	1	1	1
8' x 12'	1	2	1
8' x 14'	1	3	1
8' x 16'	1	4	1
8' x 18'	1	5	1
8' x 20'	1	6	1

SIKKERHEDSANVISNINGER

- RION er ikke ansvarlig for misbrug af værktøj eller dele.
- Det er yderst vigtigt at samle alle dele ifølge vejledningen. Følg venligst disse omhyggeligt, og spring ikke trin over.
- Vi anbefaler kraftigt, at der anvendes arbejdshandsker under montering.
- Hvis der anvendes en trappestige, eller elektriske værktøjer, så vær venligst sikker på at du følger producentens sikkerhedsanvisninger.
- Hvis lokal bygge Lovgivning kræver tilladelse eller licens, så vær sikker på at disse er indhentet inden der begyndes.
- Din 8 fods Havestue bør sikres til det forberedte fundament, ved hjælp af de anbefalede dele.
- Forsøg ikke at samle Havestuen i blæst, eller under våde forhold.
- Smid alle plastikposer væk. Hold dem venligst uden for små børns rækkevidde.
- Hold børn væk fra monteringsområdet.
- Under montering, skub ikke til, eller læn dig ikke op ad Havestuen.
- Forsøg ikke at samle denne 8 fods Havestue hvis du er træt, har indtaget stoffer eller alkohol, eller hvis du har tilbøjelighed til at blive svimmel.
- Når din 8 fods Havestue er fuldt samlet, så kontroller den for skarpe kanter, og trim disse med en barberkniv om nødvendigt.
- Hvis du bor i et område med varmt klima, hvor de udendørs temperaturer overstiger 46° C (115° F) under solen eller 36° C (99° F) i skyggen, kan dette forårsage at temperaturen inden i Havestuen overstiger 55° C (131° F).
Sådanne forhold kan skade dine planter, og vil skade Havestuen ved at vride de strukturbærende profiler. For at undgå skade:
 - Vær sikker på at der er god ventilation på varme dage.
 - Vær sikker på at temperaturen inden i den 8 fods Havestue aldrig overstiger 55° C (131° F) ved at sørge for en skyggeskærm, som Shade Net (som kan fås som ekstraudstyr).

Bemærk: RION er ikke ansvarlig for nogen skade, som sker på grund af høje temperaturer.

* Luk altid tagventilen ved kraftig vind.

PÅKRÆVET VÆRKTØJ

- GT1 - Specialværktøj til at forbinde stifter gennem huller der er på linje. Stiftværktøj som fikserer og holder profiler på plads.
- For at samle dette produkt, vil du have brug for følgende værktøjer (disse er ikke inkluderet i leveringen).



INDEN MONTERING

- RION er ikke ansvarlig for misbrug af værktøj eller dele.
- Valg af sted - Den 8 fods Havestue skal anbringes og fikseres et sted med jævn overflade.
- Sorter delene og kontroller disse i forhold til indholdslisten. Påbegynd ikke monteringen hvis dele mangles.
- Hvis du forbereder et betonfundament, så opgrav og hæld ikke beton i frossen jord.
- Vi anbefaler at du anbringer din 8 fods Havestue et sted hvor der er direkte sollys, og hvor den er beskyttet mest muligt for vind. Døren bør ikke vende mod fremherskende vindretninger.

UNDER MONTERING

Trin 1: Beslut hvilken side døren skal være. Beslutningen vil påvirke de følgende trin.

Trin 1, 3: Arranger alle 2D forbindelsesdele med det påstemplede ord "UD"; så disse vender udad fra Havestuen.

Trin 4:

- Vær sikker på at rammen er fuldstændig lige, ved at måle og verificere at de er i niveau.
- Vær sikker på at rammen er i niveau og forankr den til underlaget med skruer / skruer + dibble / spyd (ikke inkluderet), i overensstemmelse med det valgte underlag.
- Den mur hvortil du vil fastforankre din 8 fods Havestue, skal have en vinkel på 90° i forhold til fundamentet.

Trin 17:

- Vær sikker på at rammen er fuldstændig lige ved at afmåle og verificere at den er i niveau.
- Vær sikker på at rammen er i niveau og fastforankr den til væggen med skruer / skruer + dibble / spyd (ikke inkluderet eksl. del nr. BC1), i overensstemmelse med den valgte overflade.
- Den mur hvortil du fastgør din Havestue skal have en vinkel på 90° i forhold til fundamentet.

Bueprofiler til forstærkning

Trin 18-23:

- Vær sikker på at alle metalprofiler er indsat i plastikprofilerne.
- Gentag hvert trin afhængigt af din Havestues størrelse og antallet af bueprofiler, der skal samles som illustreret. (Disse monteringsvejledninger henviser kun til Havestue 8'x8' og 8'x10').

Trin 27: Vær sikker på at profilerne er fuldstændigt rettet ud, ved at måle og verificere at de er i niveau.

Forankr del **7937** til jorden med skruer / skruer + dibble / spyd (ikke inkluderet), afhængigt af den valgte overflade.

Trin 28: Gentag **trin 24-27** alt efter antal købte moduler.

Trin 30: Gentag og se **trin 4**.

Trin 39-40: Gentag og se **trin 17**.

Trin 41: Forsegel kanterne på Havestuen med silikone fugemasse.

Trin 57: Indsæt gummilisten (**del GF**) fra ydersiden af Havestuen. Skær de tilbageværende kanter af.

Trin 64: Indsæt gummilisten (**del 7869**) fra ydersiden af Havestuen. Under dette trin, drej døren for at kunne indsætte gummilisten korrekt.

Trin 66: Beslut dørens retning. Døren kan monteres og åbne som enten en højre- eller venstrevendt dør.

Trin 69: Juster hængslernes højde i overensstemmelse med den øvre opstander og den nedre rampe, som specificeret i niveau C.

Trin 73: Døren kan installeres i enten højre eller venstre side. Denne vejledning viser samlingen af en højresidet dør. Vælg en af de to viste muligheder.

VÆR OPMÆRKSOM:

 Når du møder informationsikonet, se venligst det relevante monteringstrin for yderligere bemærkninger og assistance.

 Dette ikon indikerer at montøren bør være inden i produktet.

NN

VIKTIG

Les denne bruksanvisningen nøye for du monterer SunRoom 8'.

Oppbevar denne bruksanvisningen på et trygt sted for fremtidig referanse.

GENERELT

- RION er ikke ansvarlig for misbruk av verktøy eller deler
- Alle ugjennomsiktige paneler med de stemplede ordene DENNE SIDEN UT indikerer utsiden for å oppnå full UV beskyttelse. Fjern plastikk klistre når panelene låses på plass.
- Alle gjennomsiktige paneler beskyttes av en plastfilm på begge sider, og har ingen bestemt retning for installering. Fjern plastfilmen før installasjonen.
- Antall deler som kreves for forlenging er avhengig av antall pakker kjøpt.
- Døren kan monteres på venstre eller høyre side; i tillegg kan du bestemme åpningsretningen for døren.
- Spesifikke skruer og bolter må kjøpes basert på overflaten (vegg og grunnflate) som SunRoom 8' skal monteres på.

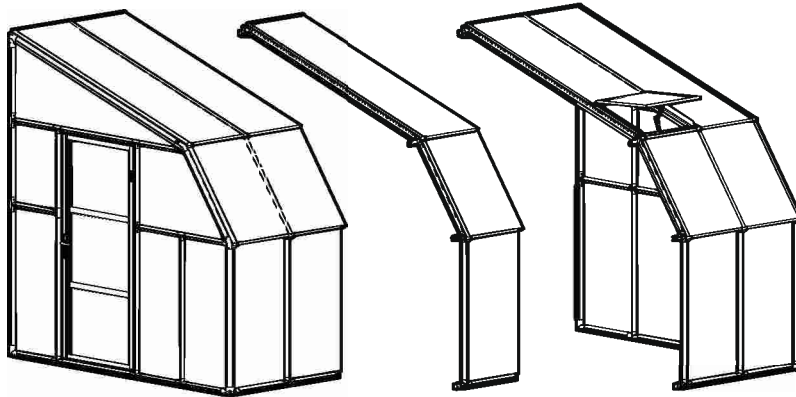

Front 4'

Midt 2'

Bakdel 4'

Drivhus Størrelser	Pakke kvantitet (Front 4')	Pakke kvantitet (Midt 2')	Pakke kvantitet (Bakdel 4')
8' x 8'	1	x	1
8' x 10'	1	1	1
8' x 12'	1	2	1
8' x 14'	1	3	1
8' x 16'	1	4	1
8' x 18'	1	5	1
8' x 20'	1	6	1

SIKKERHETSÅD

- RION er ikke ansvarlig for misbruk av verktøy eller deler.
- Det er veldig viktig å montere alle delene i henhold til retningene. Følg dem nøye og ikke hopp over noen av stegene.
- Vi anbefaler på det sterkeste å bruke arbeidshansker under montering.
- Hvis man bruker gardintrapp eller elektroverktøy for å sikre at du bruker produsentens sikkerhetsråd.
- Hvis lokale bygningsforskrifter krever tillatelser eller lisenser, pass på at disse innhentes før begynnelsen.
- Ditt SunRoom 8' bør sikres til den klargjorte grunnen før man bruker anbefalt maskinvare.
- Ikke prøv å montere SunRoom 8' i sterk vind eller våte forhold.
- Kast alle plastikkposer. Hold dem utilgjengelige for små barn.
- Hold barn unna monteringsområdet.
- Ikke len deg mot eller skyv SunRoom 8' under bygging.
- Ikke forsøk montering av SunRoom 8' hvis du er trøtt, under påvirkning av narkotika eller alkohol eller ved svimmelhet.
- Når SunRoom 8' er montert må man undersøke det for skarpe kanter og trimme med en barberhøvel om nødvendig.
- Hvis du bor i et varmt klima, hvor utendørstemperaturer overstiger 46° C (115° F) i solen eller 36° C (99° F) i skyggen, kan dette forårsake at temperaturen inne i SunRoom 8' til å overstige 55° C (131° F). Slike forhold kan skade plantene og vil skade SunRoom 8' ved fordreining av den strukturelle profilen. For å forebygge skade:
 - Forsikre god ventilasjon på varme dager.
 - Pass på at temperaturen inne i SunRoom 8' aldri overstiger 55° C (131° F) ved å bruke en skjerm for skyggelegging, som Shade Net (tilgjengelig tilbehør).

Merk: RION er ikke ansvarlig for skade som følge av høye temperaturer.

* Alltid lukk takventilen i sterk vind.

NØDVENDIGE VERKTØY

- GT1 - Spesialverktøy for å koble til nålene gjennom hullene. Fest nålene og lås profilene på plass.
- For å montere dette produktet må du ha følgende verktøy (disse medfølger ikke).



FØR MONTERING

- RION er ikke ansvarlig for misbruk av verktøy eller deler.
- Velg et grunnlag - SunRoom 8' må posisjoneres og festes på en flat overflate.
- Sorter delene og sjekk mot delelisten. Ikke begynn monteringen hvis det mangler deler.
- Hvis du preparerer et betongfundament, så må du ikke grave og støpe i frosen jord.
- Vi anbefaler at du plasserer SunRoom 8' på et sted hvor det vil få direkte sollys og beskyttes mot sterk vind så mye som mulig. Døren bør ikke møte rådende vinder.

UNDER MONTERING

Steg 1: Bestem hvilken side å henge døren. Denne beslutningen vil påvirke de kommende stegene.

Steg 1, 3: Ordne alle 2D-kontakter med det stemplede ordet "UT" på utsiden av SunRoom 8'.

Steg 4:

- Pass på at rammen er helt rett ved å måle og bekrefte at de er jevne.
- Pass på at rammen er helt rett og ankre den til grunnlaget med skruer / skruer + dibble / pigg (medfølger ikke) i henhold til valgt overflate.
- Veggen som du sikrer SunRoom 8' må være 90° i forhold til grunnlaget.

Steg 17:

- Pass på at rammen er helt rett ved å måle og bekrefte at de er jevne.
- Pass på at rammen er helt rett og ankre den til grunnlaget med skruer / skruer + dibble / pigg (medfølger ikke del # BC1). i henhold til valgt overflate.
- Veggen som du sikrer ditt SunRoom til må være 90° i forhold til grunnlaget.

Forsterking av buer

Steg 18-23:

- Forsikre at alle metallprofilene settes inn i plastprofilene.
- Gjenta hvert steg avhengig av størrelsen og antall buer som må installeres på ditt SunRoom 8' som anvist. (Disse monteringsanvisningene gjelder kun for et SunRoom størrelse 8'x8' og 8'x10').

Steg 27: Pass på at profilene er helt rette ved å måle og bekrefte at de er jevne.

Ankre del 7937 til grunnlaget med skruer / skruer + dibble / pigg (medfølger ikke) i henhold til valgt grunnlag.

Steg 28: Gjenta steg 24-27 i henhold til antall moduler kjøpt.

Steg 30: Gjenta og henvis til steg 4.

Steg 39-40: Gjenta og henvis til steg 17.

Steg 41: Forsegle SunRoom 8' kantene med silikon.

Steg 57: Sett inn gummilisten (Del GF) fra utsiden av SunRoom 8'. Klikk de gjenværende kantene.

Steg 64: Sett inn gummilisten (Del 7869) fra utsiden av SunRoom 8'. I dette steget må man snu døren for å sette inn gummilisten korrekt.

Steg 66: Bestemmer retningen på døren. Døren kan installeres enten til venstre eller høyre.

Steg 69: Juster hengsehøyden i henhold med den øverste og lavere rampen av portåpningen, som spesifisert i nivå C.

Steg 73: Døra kan installeres enten som venstre- eller høyrevendt dør. Disse instruksjonene viser en høyrevendt dørmontering. velg en av de to angitte alternativene.





ADVARSEL:

 Når informasjonsikonet vises, henvis til det relevante monteringsstedet for ytterligere kommentarer og assistanse.

 Dette ikonet indikerer at installatøren er inne i produktet.

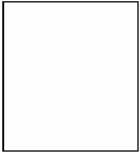

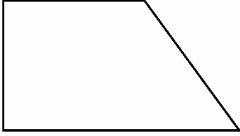
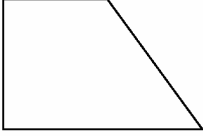

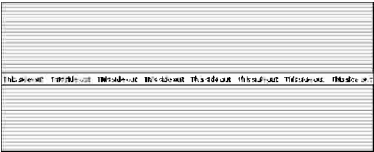
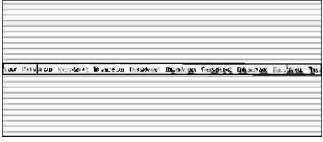



Contents

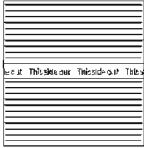
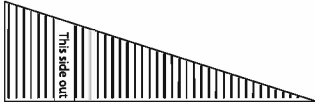

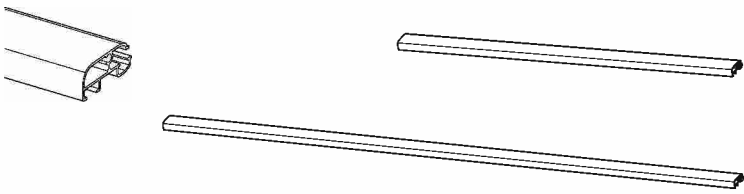
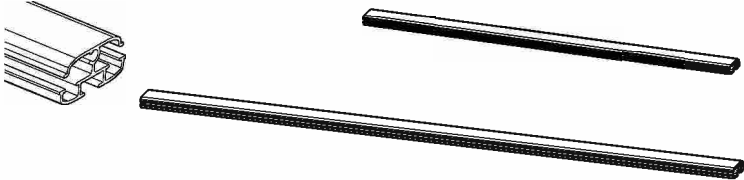
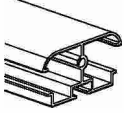
Item		Front	Back	Middle
PN55		2	2	1
PN53			2	
PN1		2	6	1
PN127		3		
PN51			1	
PN134		1		
7953		3		
7942		1		
7803		2	1	1
7802			1	

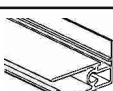

Contents



Item		Front	Back	Middle
586			1	
7801		1		
7809			1	
7612		1	1	
7805		1	1	
7614		1	2	1
7804		1	2	1
7951		2		
7552			4	2
7552 F		4		
992			2	
991			1	
989			1	
7950		1		

Contents

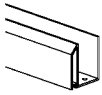
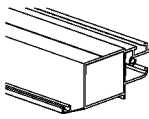
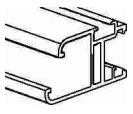

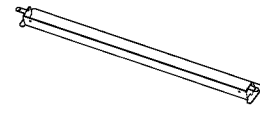
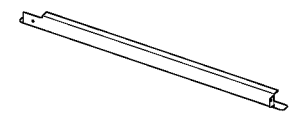
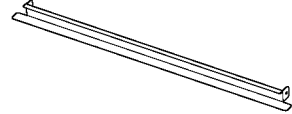
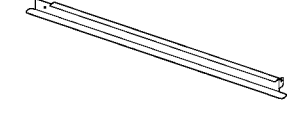
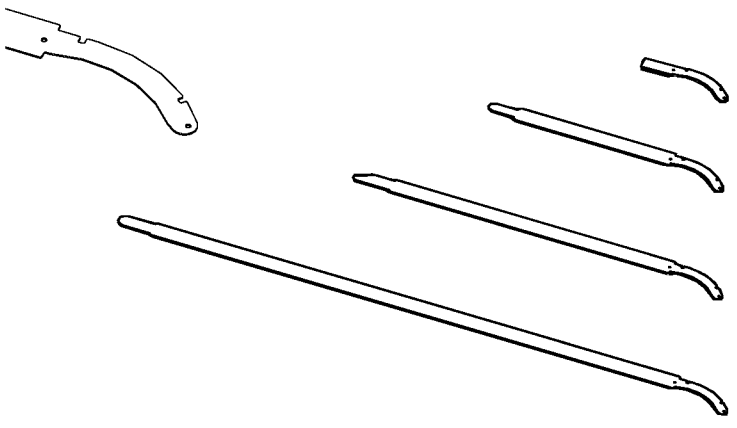
Item		Front	Back	Middle
7952		2		
7949		1		
7884		2		
7936		1	1	1
7937		1	1	
7536			1	
7534			1	
7535			1	
7533			1	
7934		1	2	1
7933		1	2	1
7935		1	2	1
7932		1	2	1









Contents

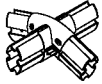
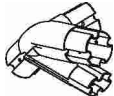

Item		Front	Back	Middle
7957			1	
DSN		1		
GF*		2	2	1
7869		1		
8017		1		
SF			1	
7608		2	3	1
7800		2	3	1
PIN1		160	160	30
72		2		
73			2	
74		2	4	2
01		1	1	
2D		6	7	1
53			1	
75		1		



Contents



Item		Front	Back	Middle
51		2	4	2
76			1	
71		1		
10			2	
11		1	1	
12		1		
13			1	
14		1	2	1
09		5	3	
SR2		1		













Contents

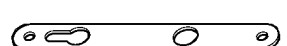

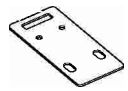
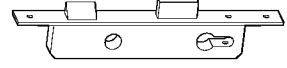
Item		Front	Back	Middle
B1		1	1	
B2		4	8	2
B3		1		
B4		3		
B5		1	1	
B12		1	1	
R1		1	1	
R4		1	1	
R10		1	1	
E1		4	5	1
E2		4	10	2
E13		2	3	
E15		1	2	1
E100		4		
E105		1		
E106		1		
E107		1	2	1

Contents



Item		Front	Back	Middle
7938		1		
7939		1		
7940		1		
7941		1		
7898		4		
7948		2		
BC1		10	2	2
7220			1	
7912		1		
7913		1		
8039		3		
7994		1		
7995		1		
7996		2		
466		26	10	4

Contents



Item		Front	Back	Middle
411		26	10	4
4008			4	
7441			1	
7442		4		
7445		4		
7224		6		
7958		1		
465			4	
422			4	
4043		8	9	3
22			1	
99			1	
GT1		1	1	
7993		1		

Contents



Item		Front	Back	Middle
7918		2		
7919		2		
7920		2		
7921		2		
7923		4		
7922		2		
7924		4		
8280		1		
8279		1		
7284		1		
7279		1		
450		2		



1 **i**

item		Qty.
B3		1
B4		1
11		1
2D		1
Pin1		6

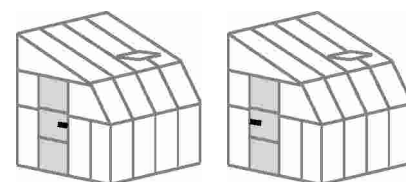
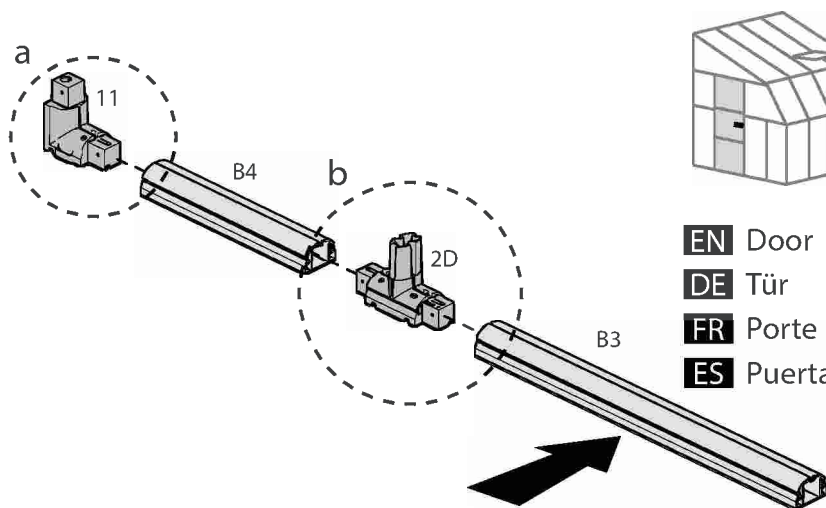
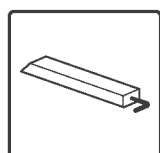
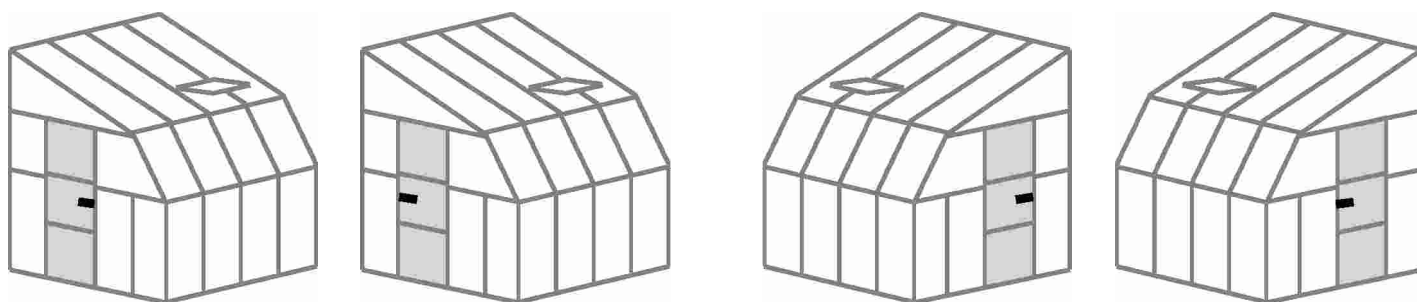

- EN** Door
- DE** Tür
- FR** Porte
- ES** Puerta

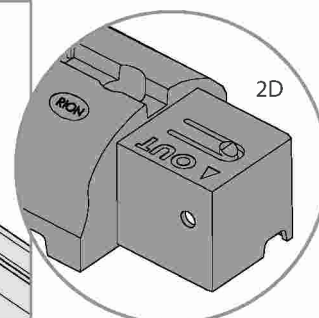
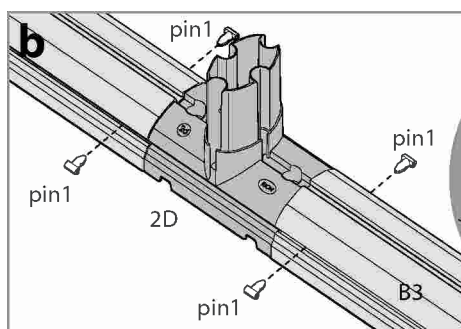
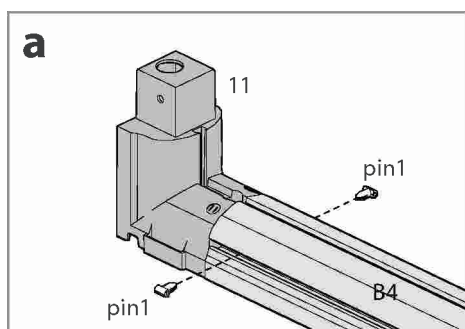

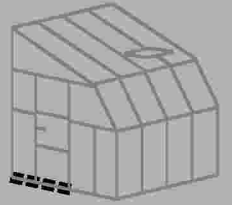

item		Qty.
SR2		1

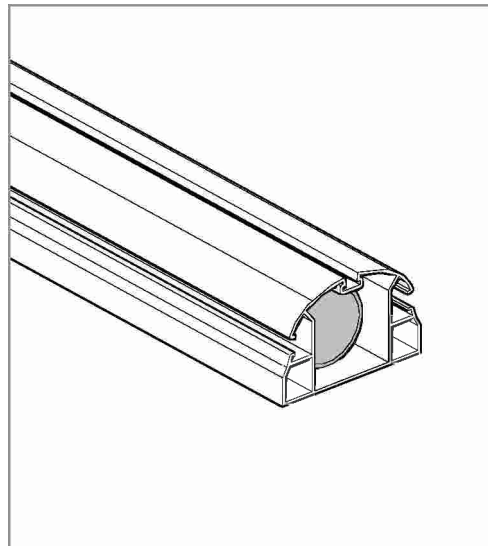
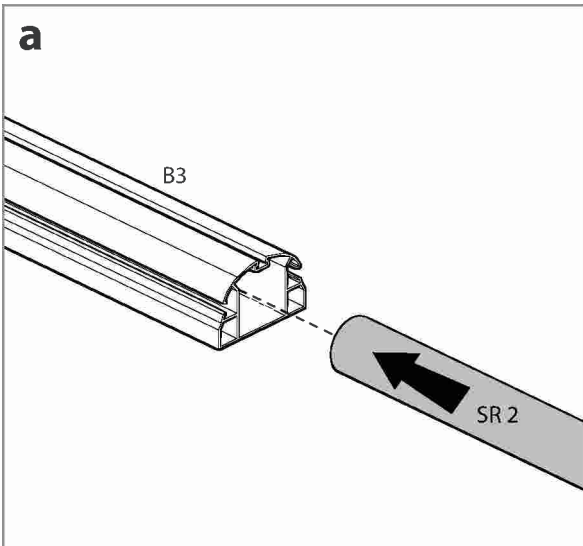
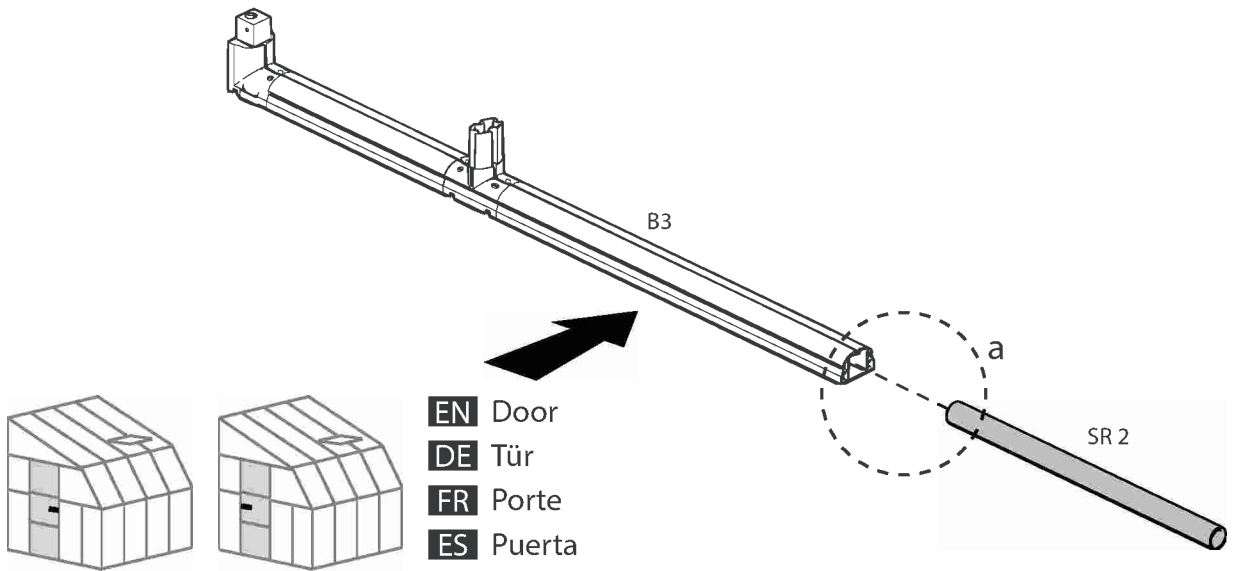

3

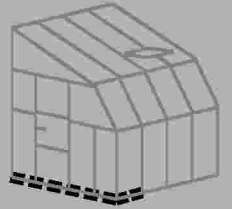

Item		Qty.
B2		1
B4		2
01		1
2D		2
pin1		12

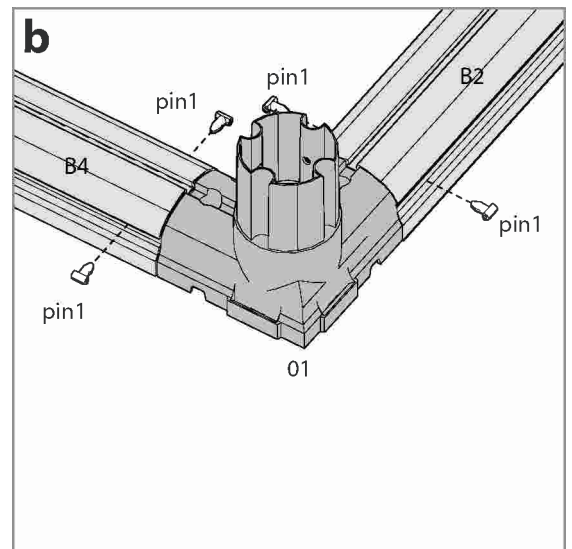
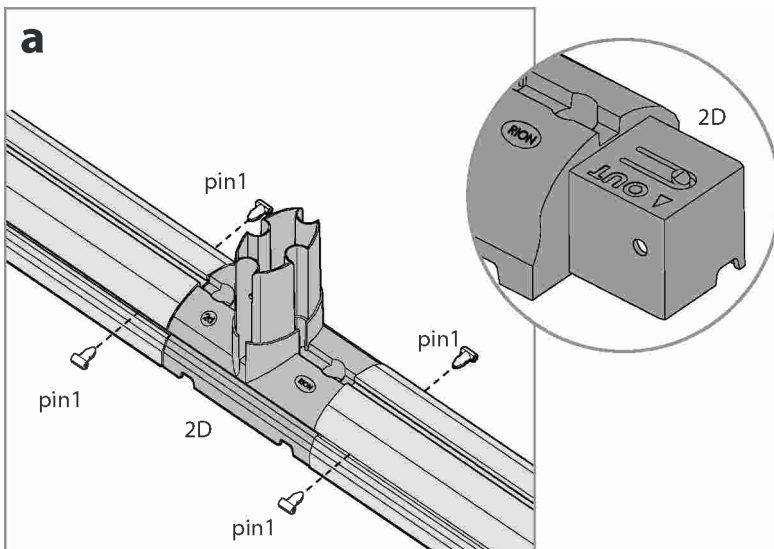
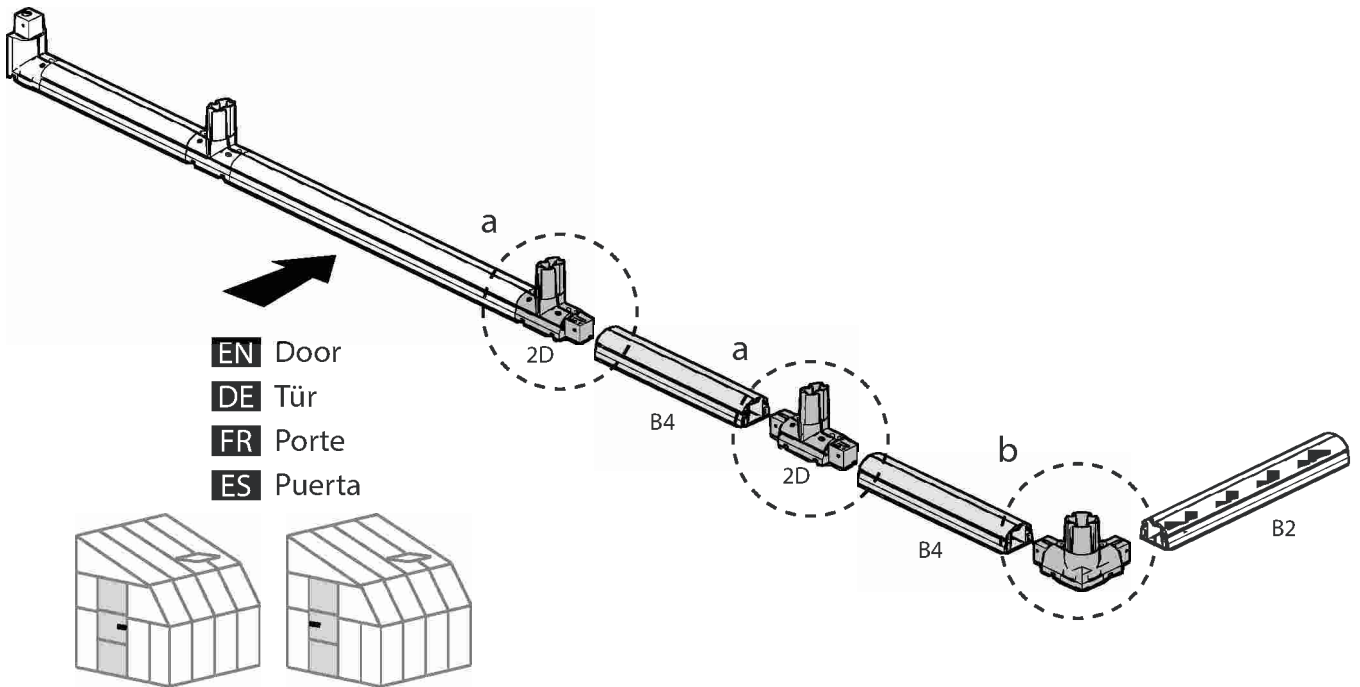
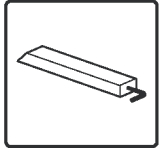

4

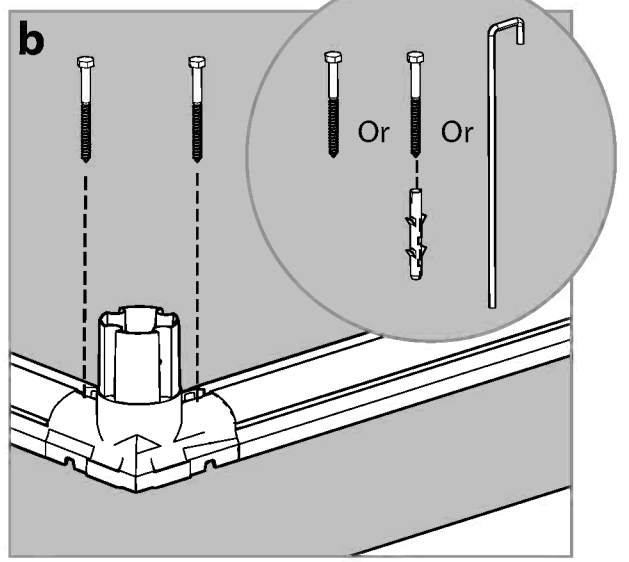
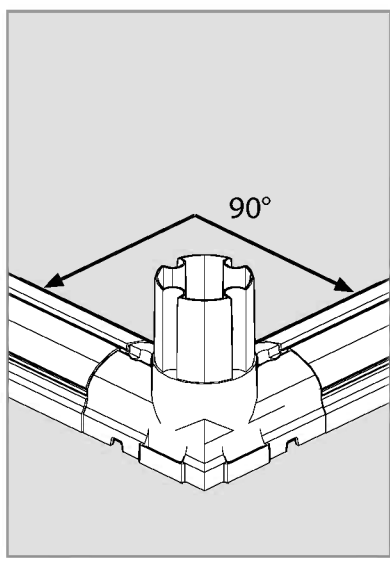
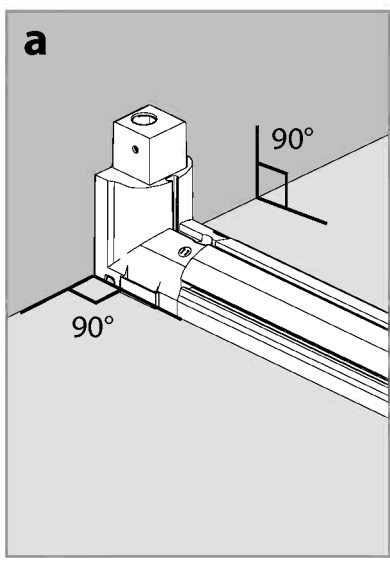
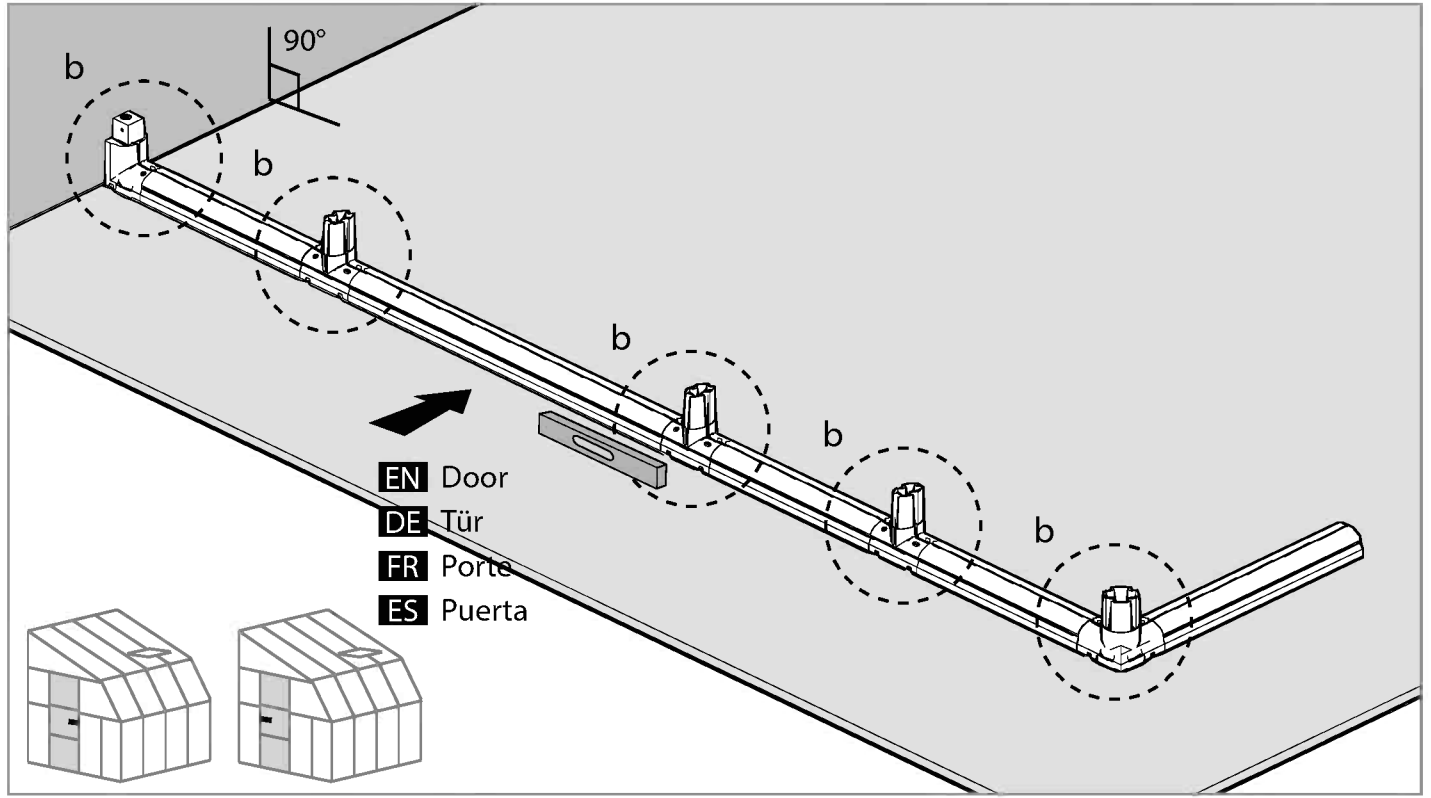
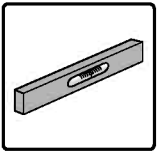
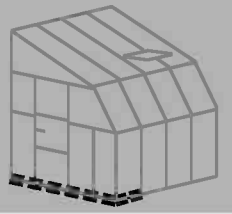

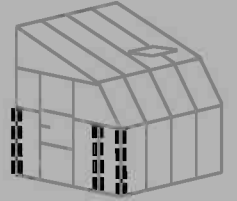

Item		Qty.
B1		1
E1		1

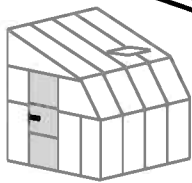
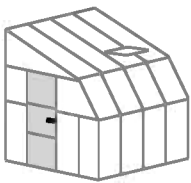
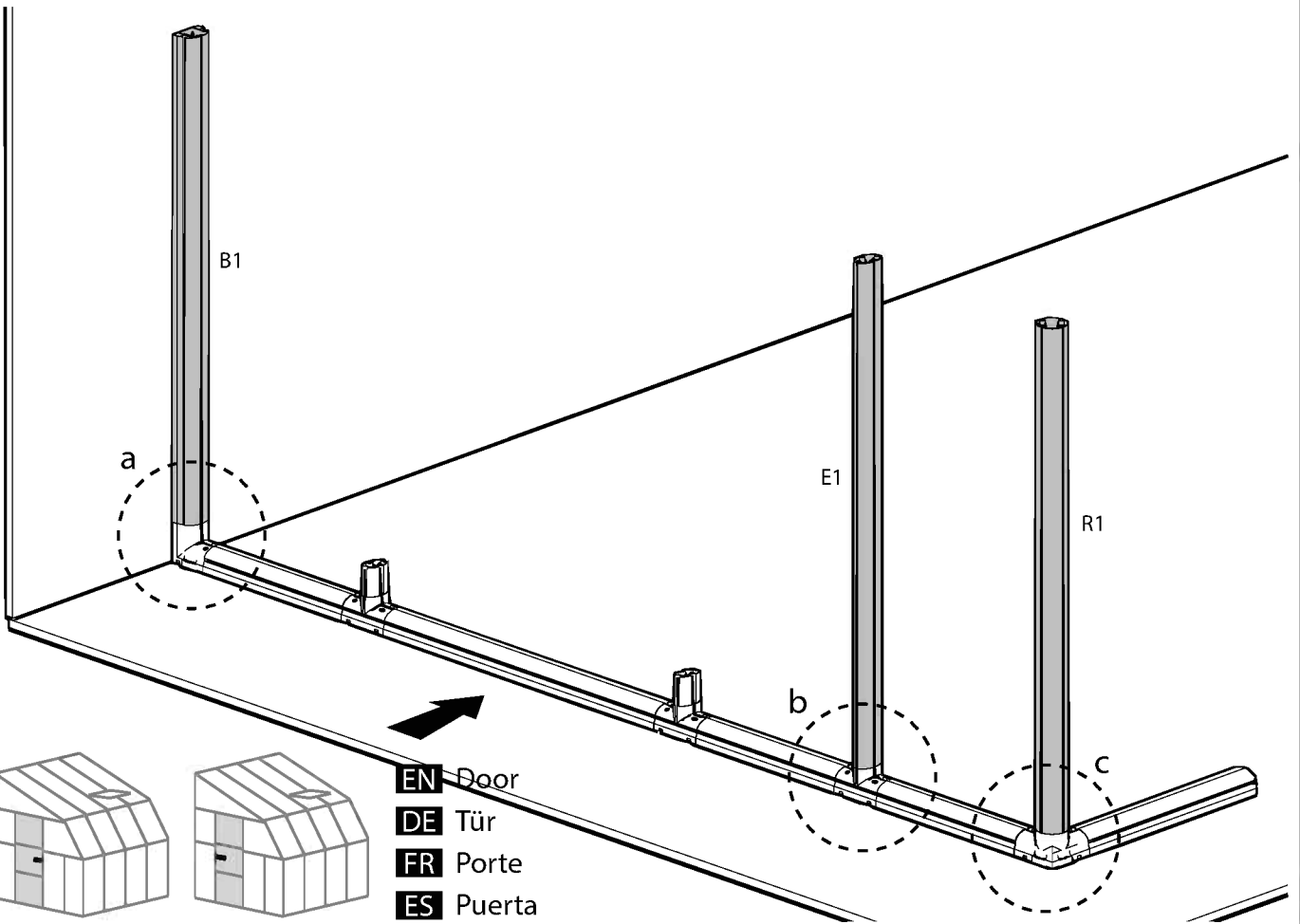
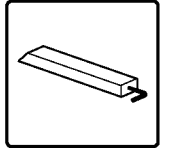

Item		Qty.
R1		1
pin1		6



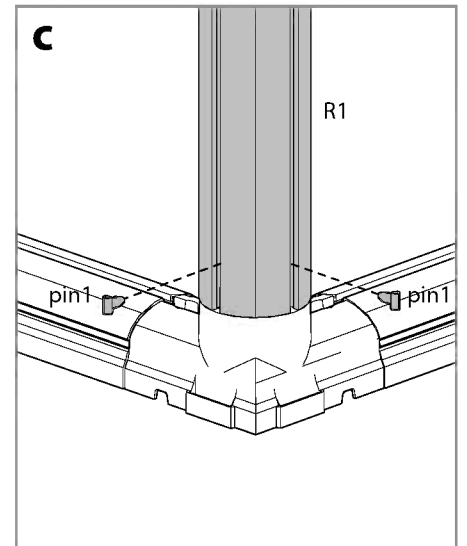
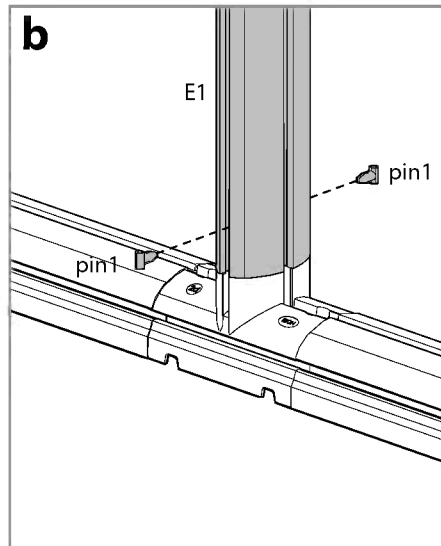
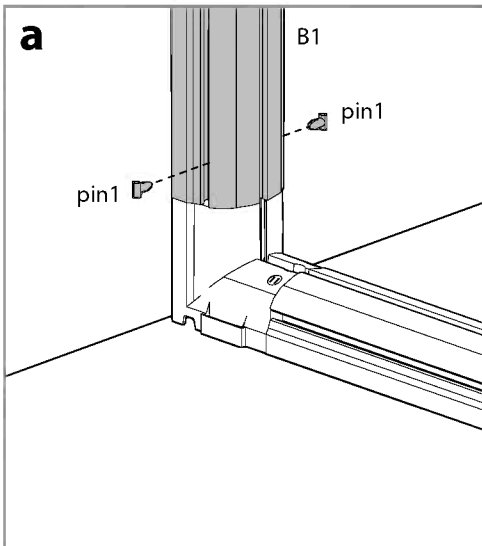

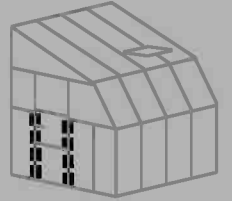
- EN** Door
- DE** Tür
- FR** Porte
- ES** Puerta





Item		Qty.
E1		2
7938		1
7939		1

Item		Qty.
7224		2
466		2

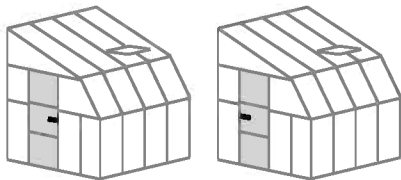
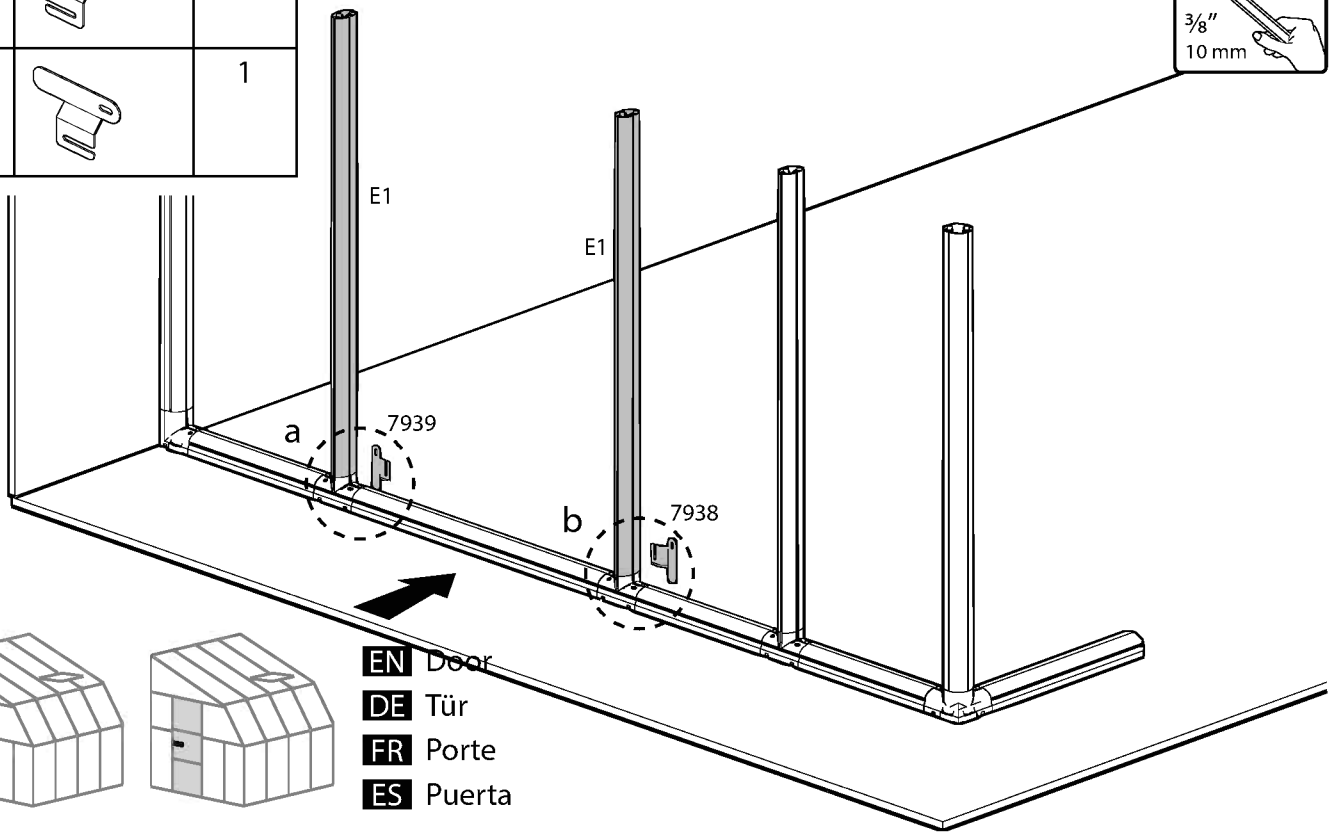
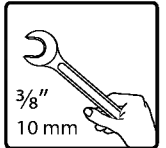
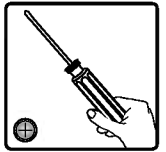

- EN** Door
- DE** Tür
- FR** Porte
- ES** Puerta

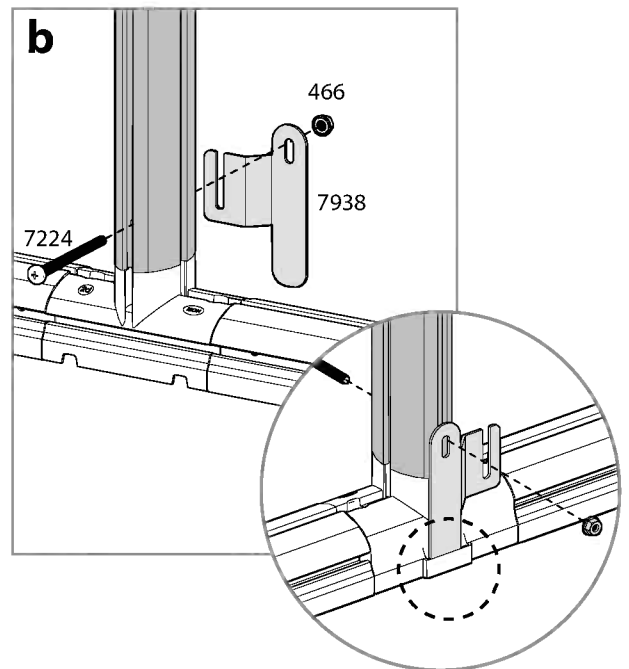
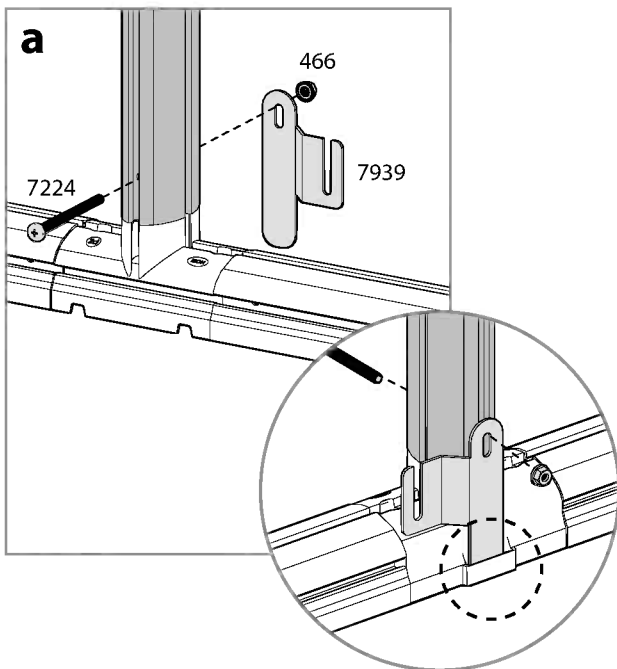

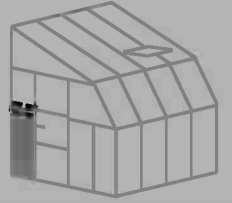

Item		Qty.
PN127		1
E100		1
2D		1

Item		Qty.
09		1
pin1		8

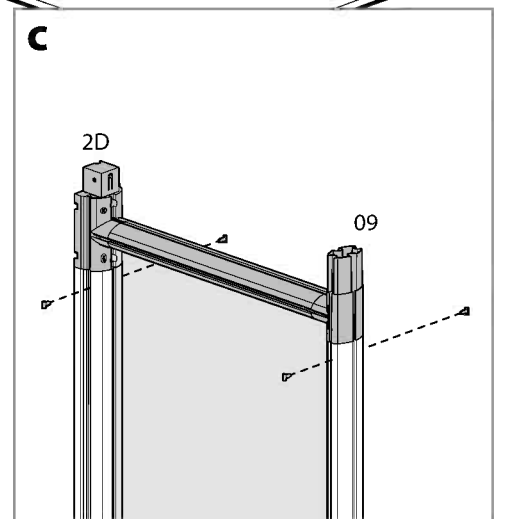
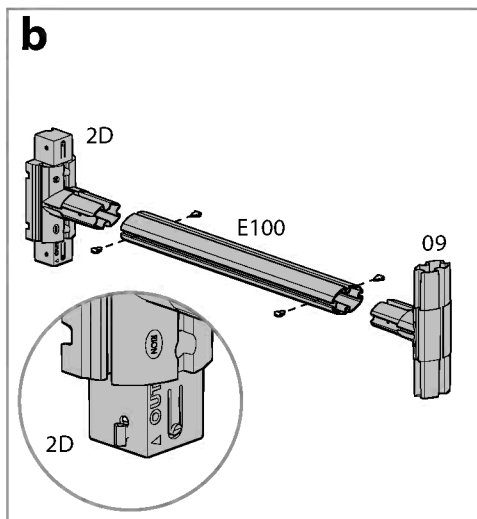
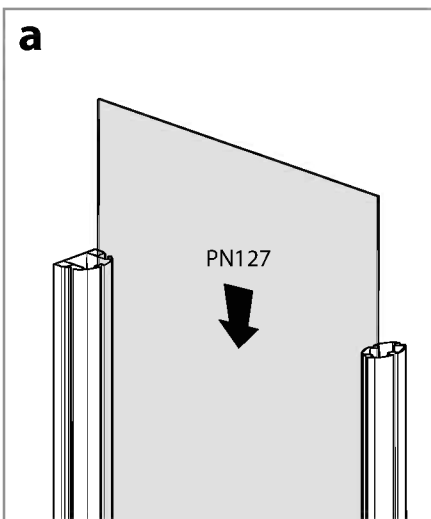
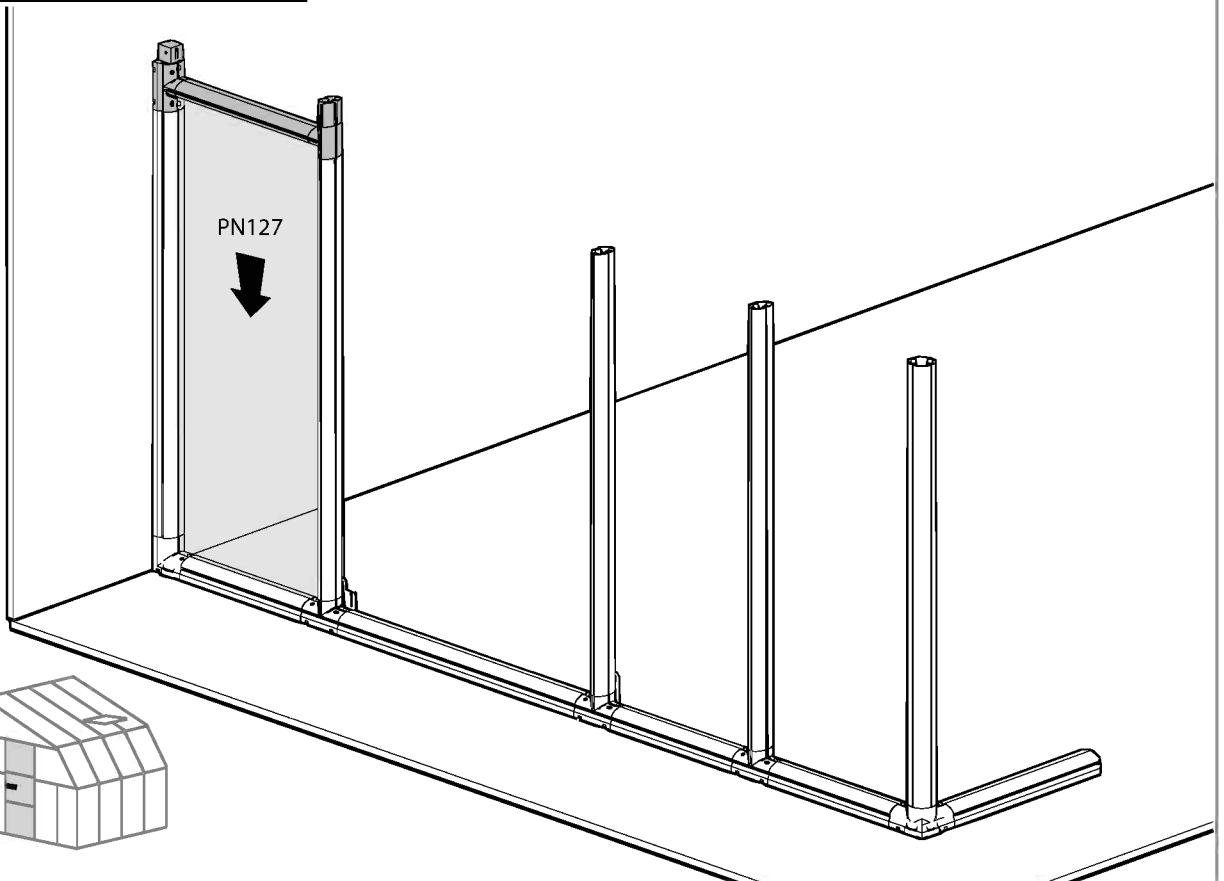
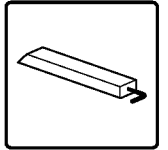

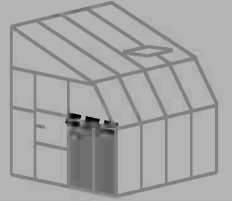



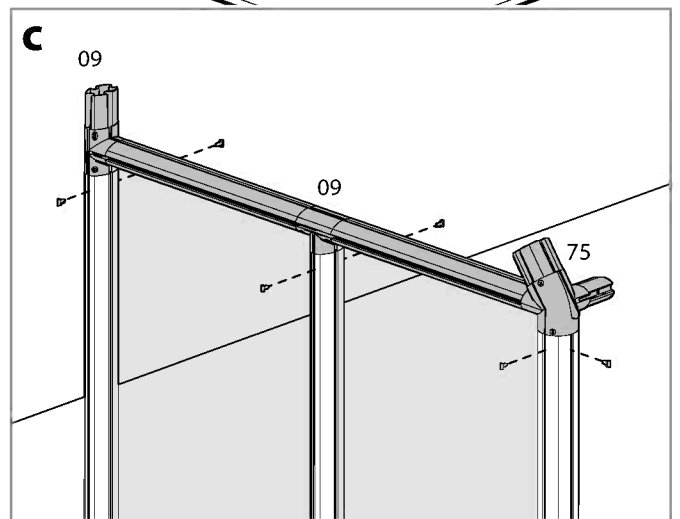
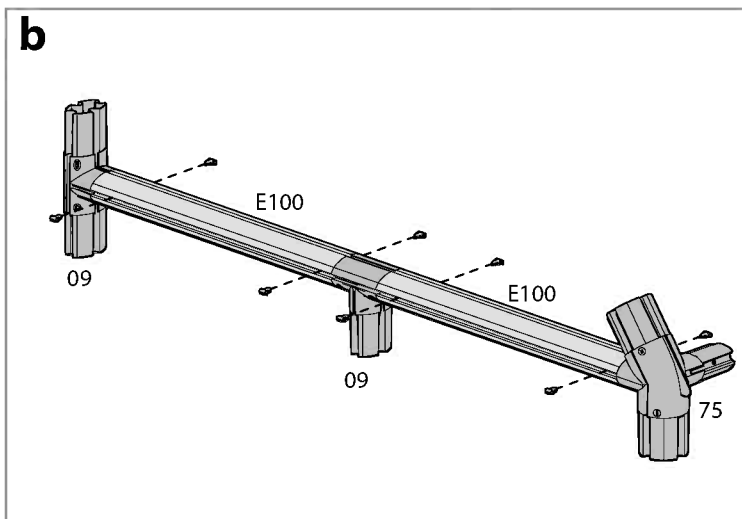
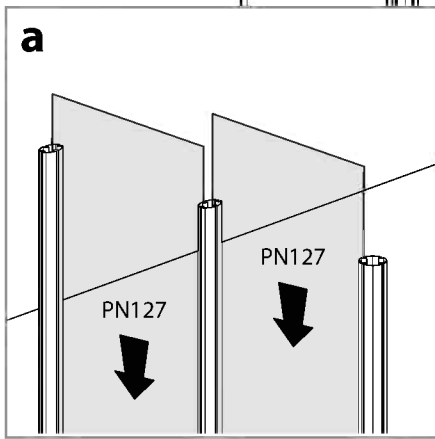
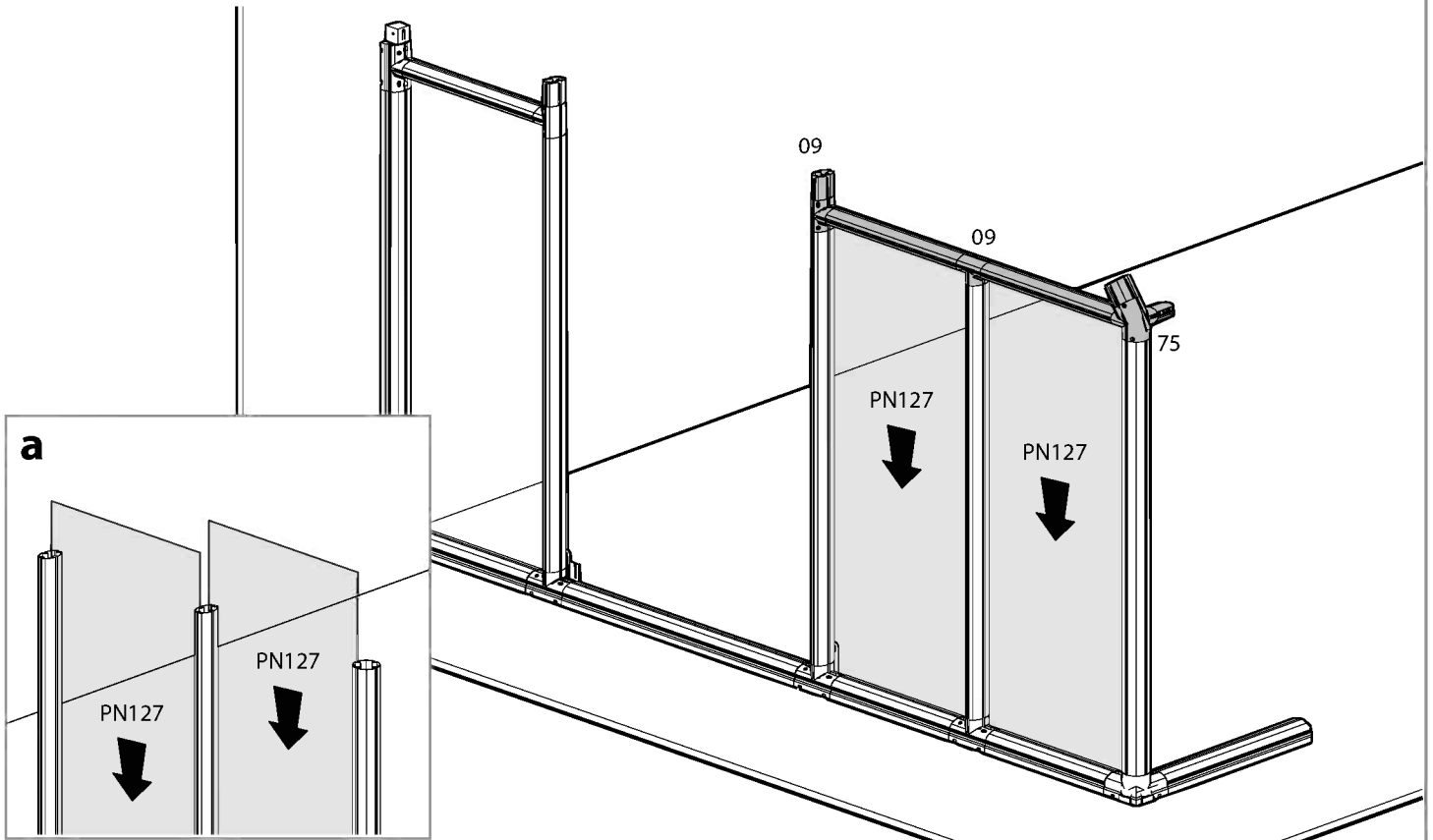
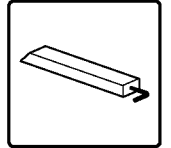

Item		Qty.
PN127		2
E100		2
75		1

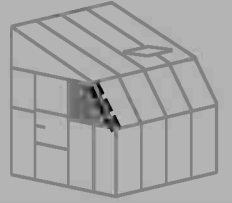
Item		Qty.
09		2
pin1		14

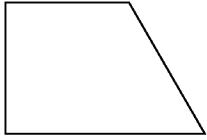

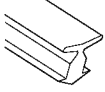



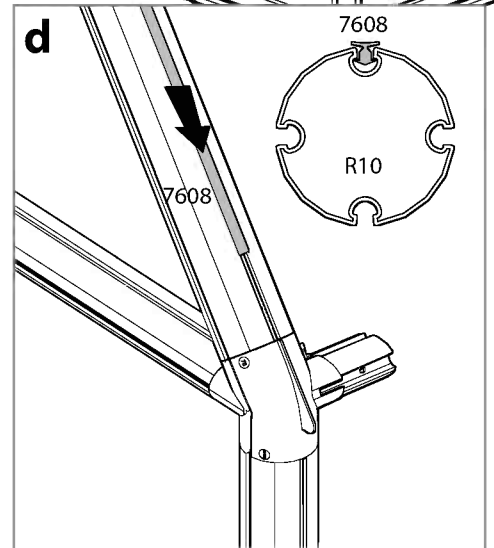
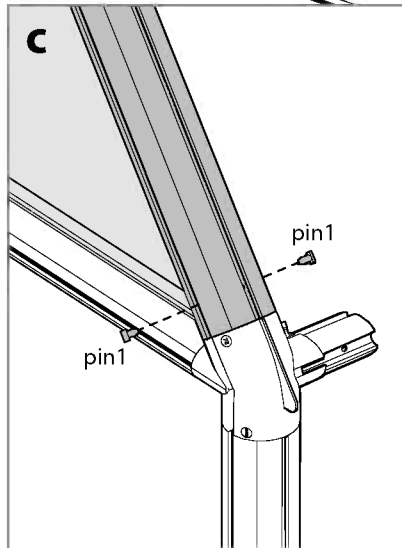
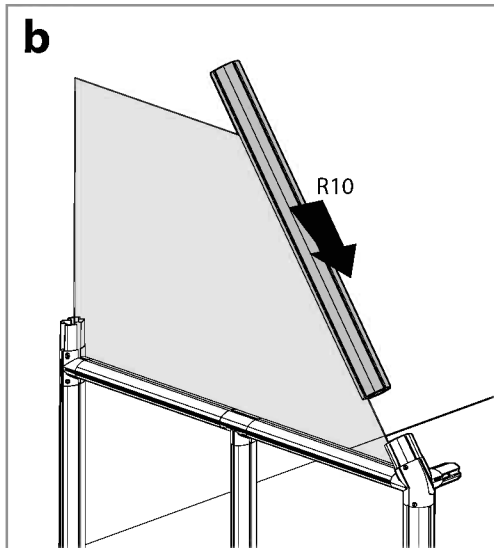
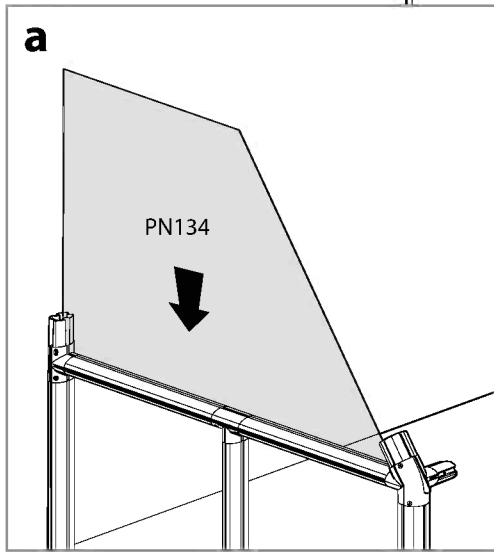
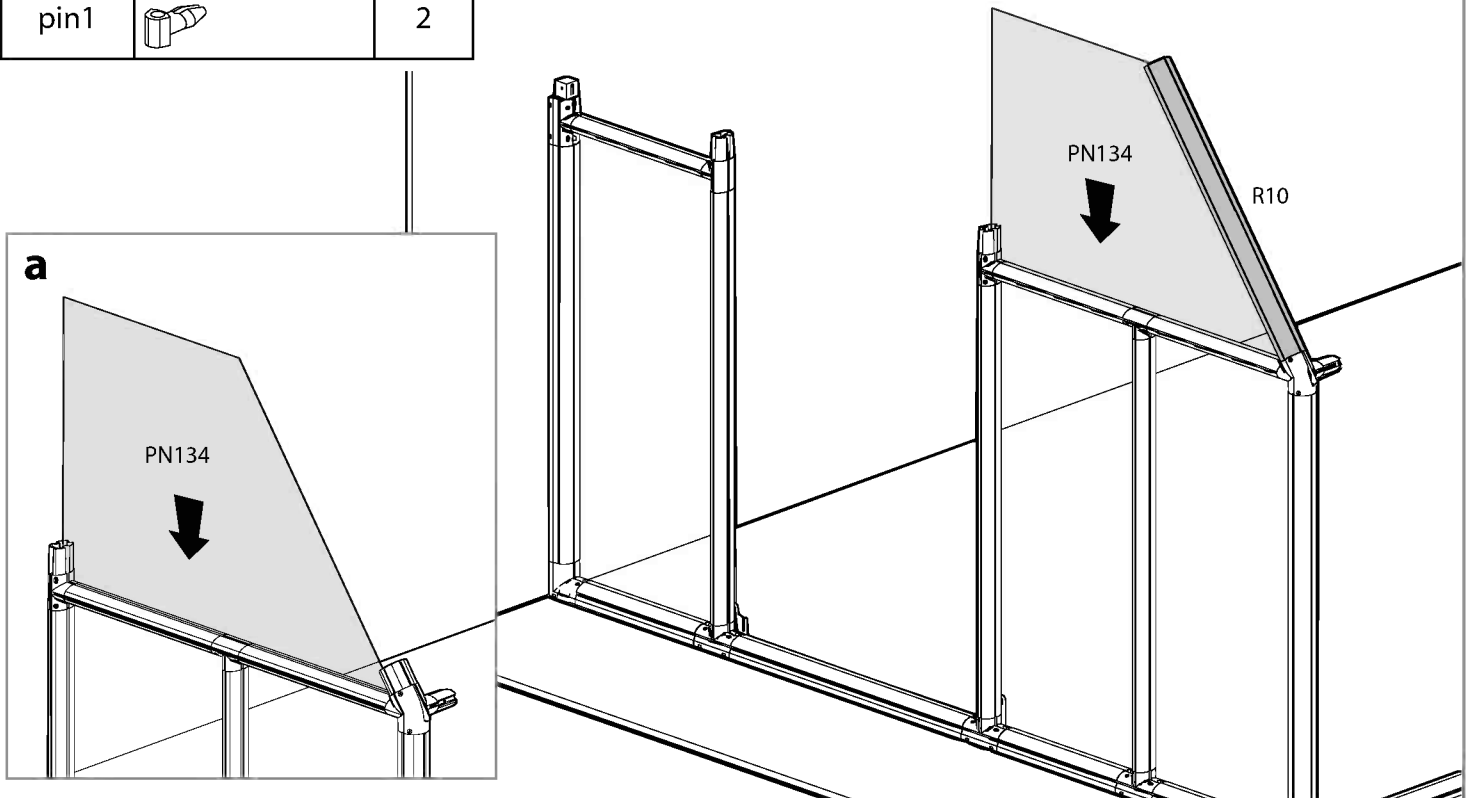
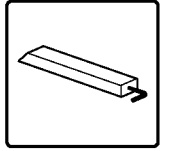

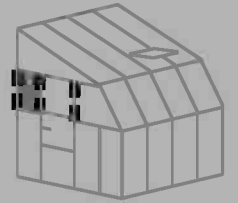
Item		Qty.
PN134		1
R10		1
7608		1
pin1		2



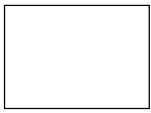

Item		Qty.
B12		1
E13		2

Item		Qty.
7942		1
pin1		6

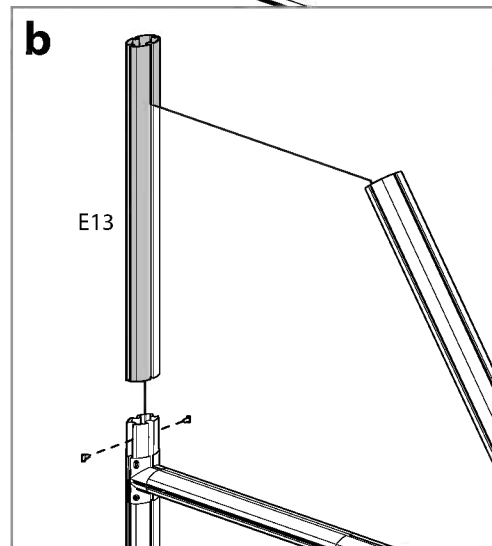
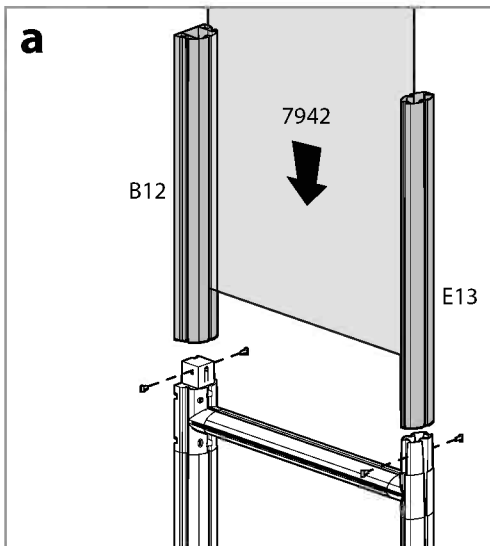
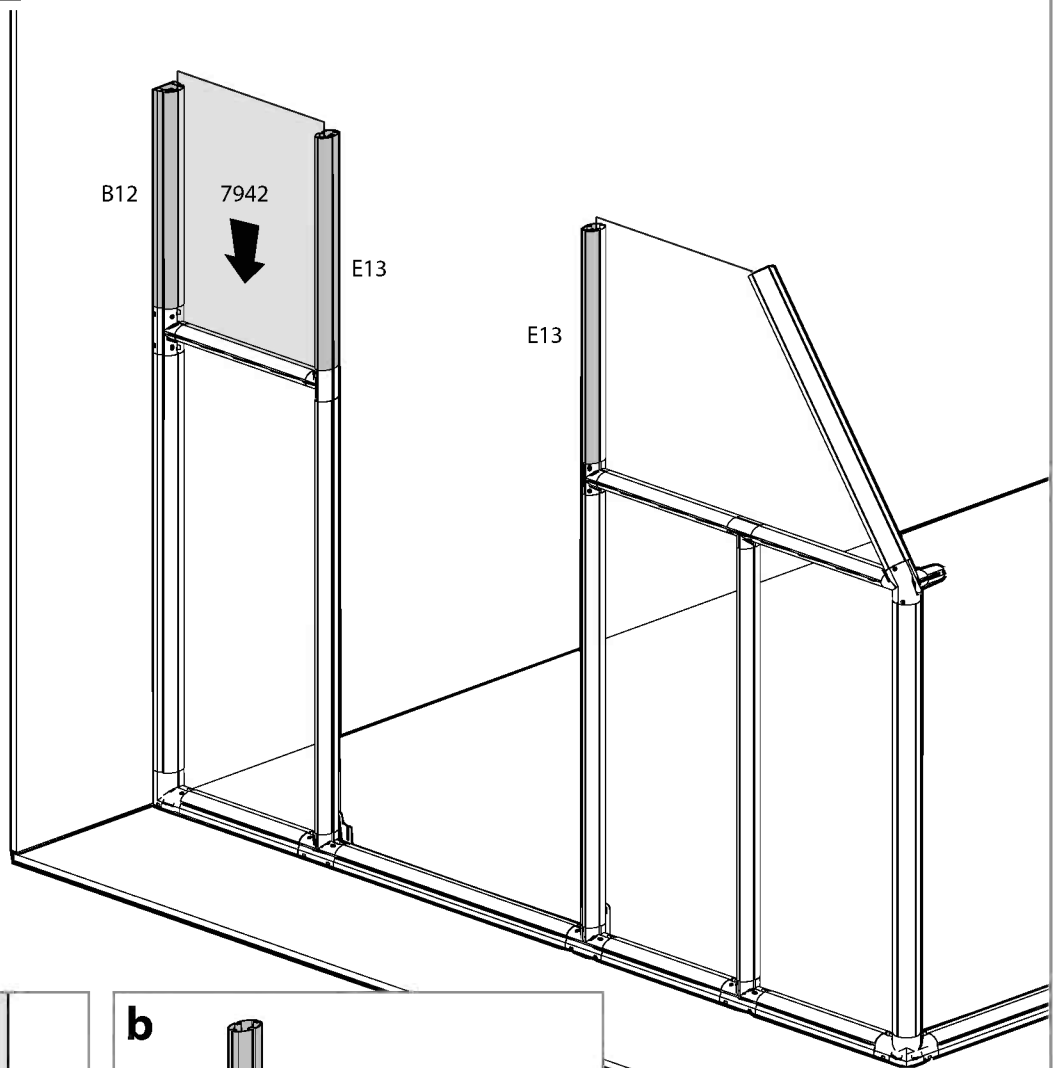
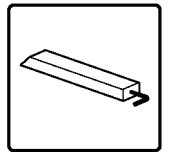

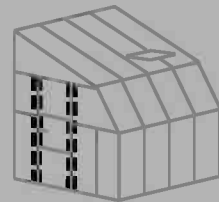

Item		Qty.
7884		2
411		8
466		8

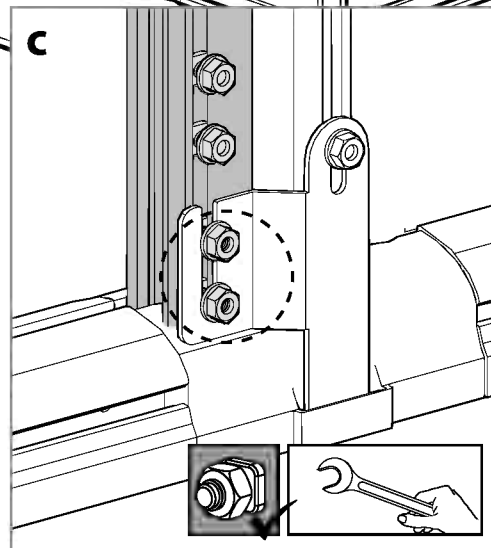
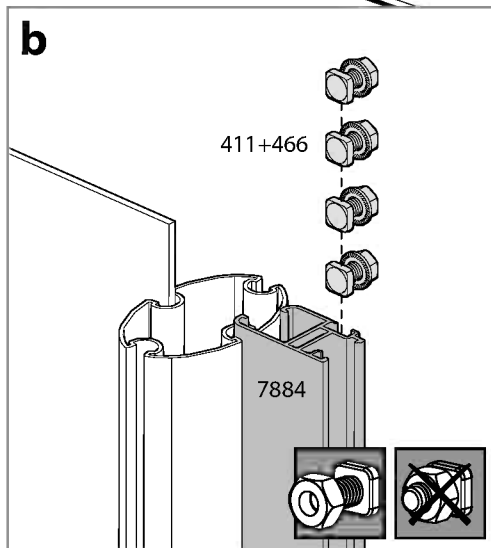
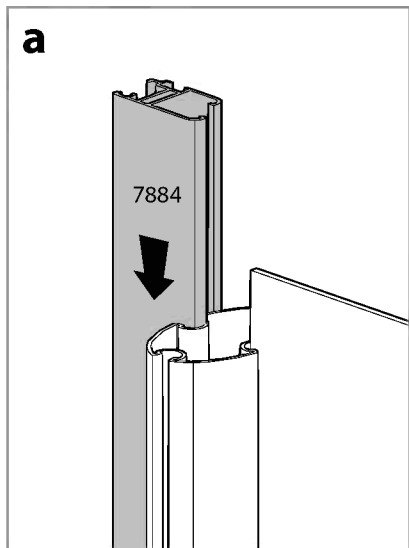
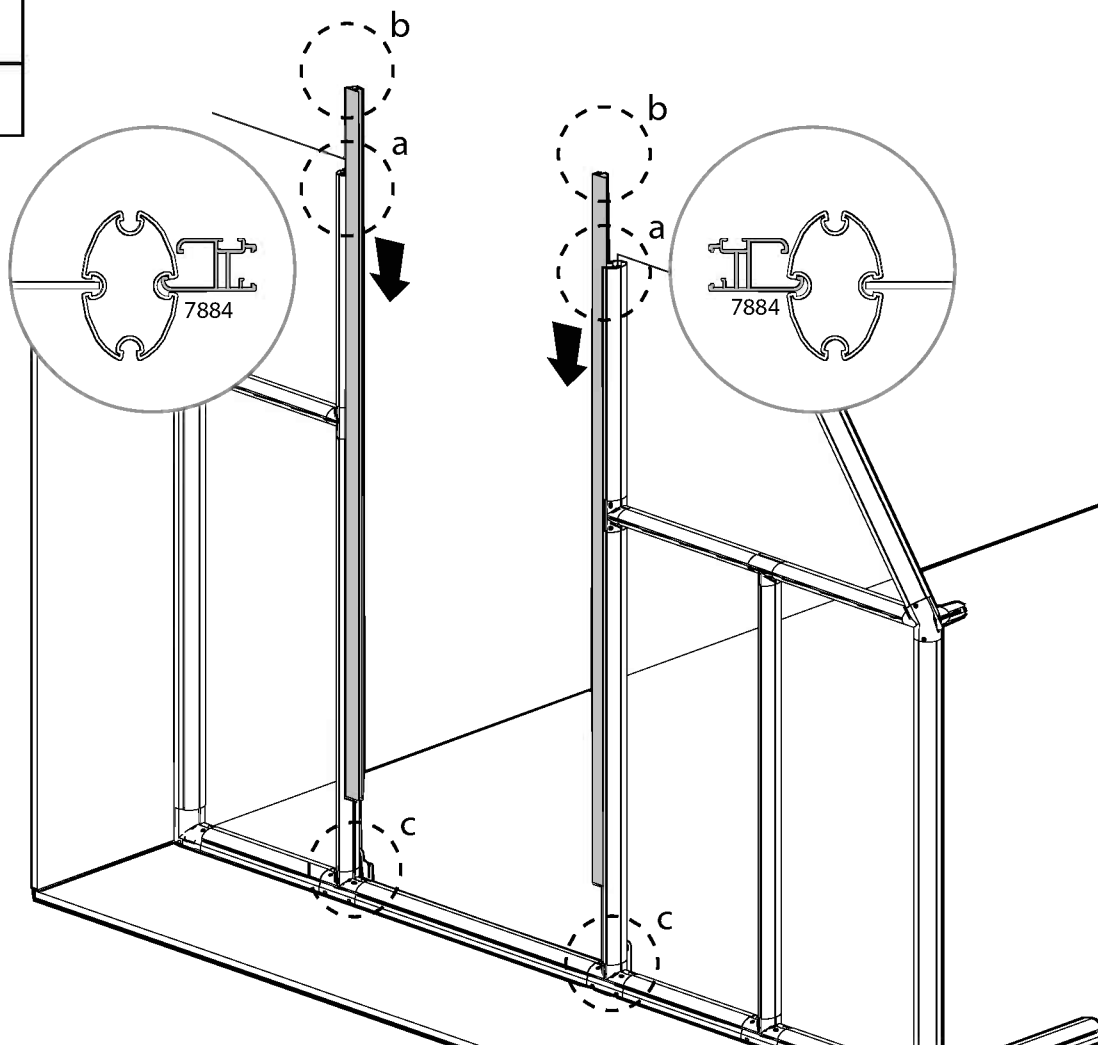
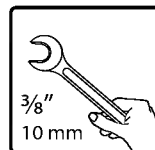

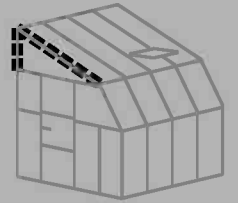

Item		Qty.
R4		1
B5		1
7800		1

Item		Qty.
12		1
pin1		4

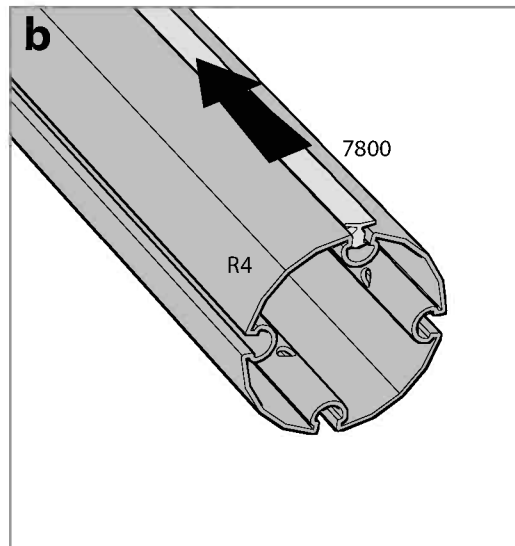
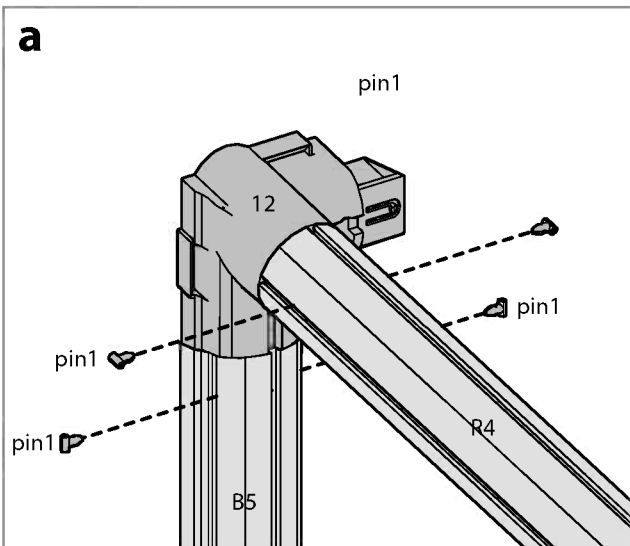
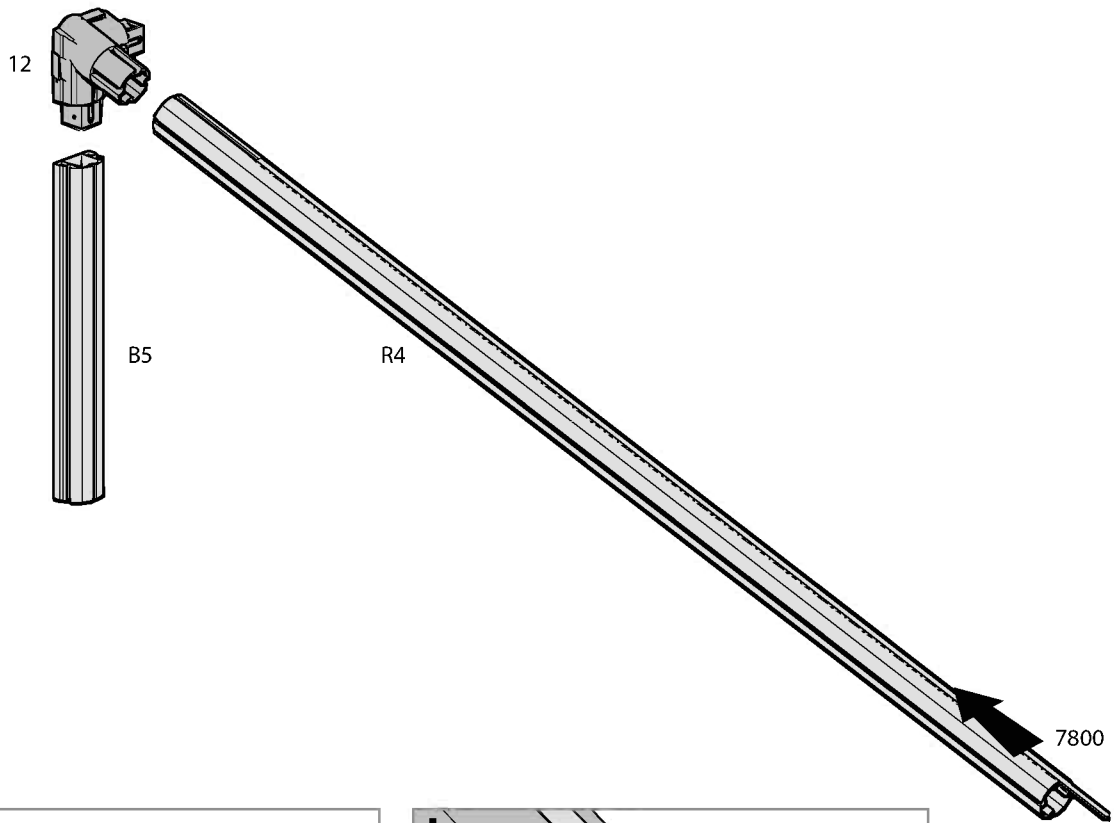
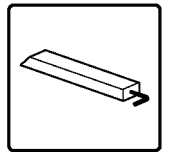

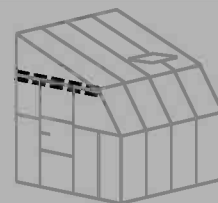



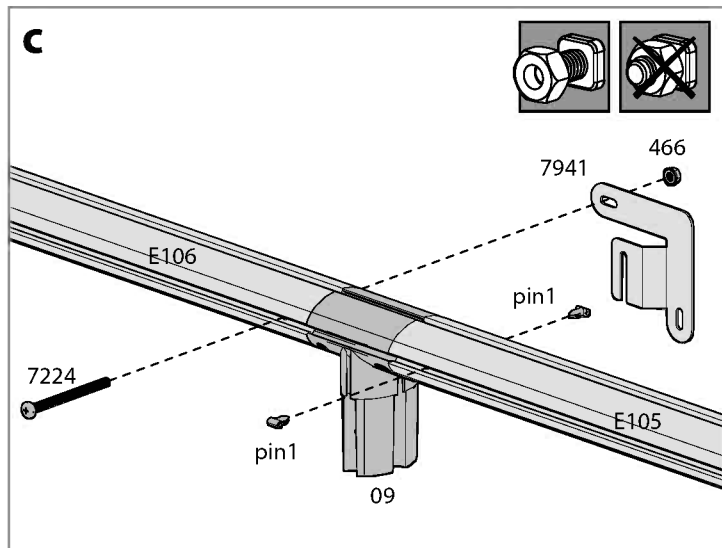
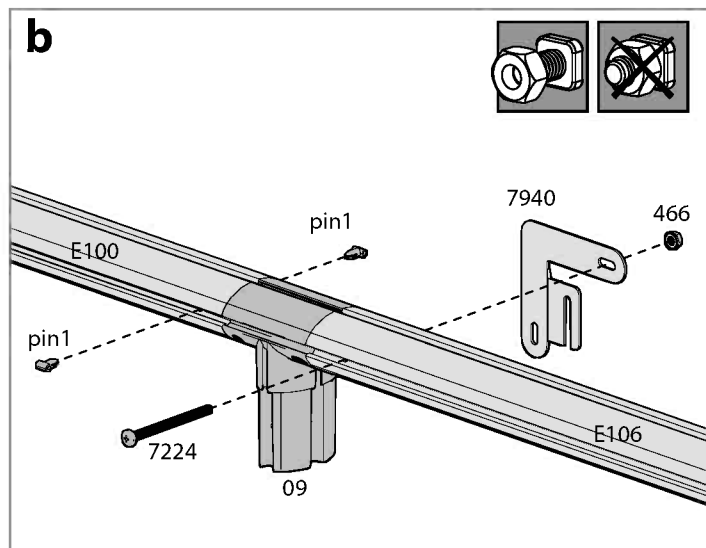
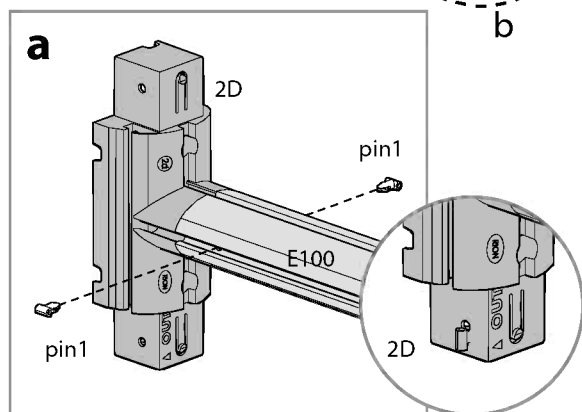
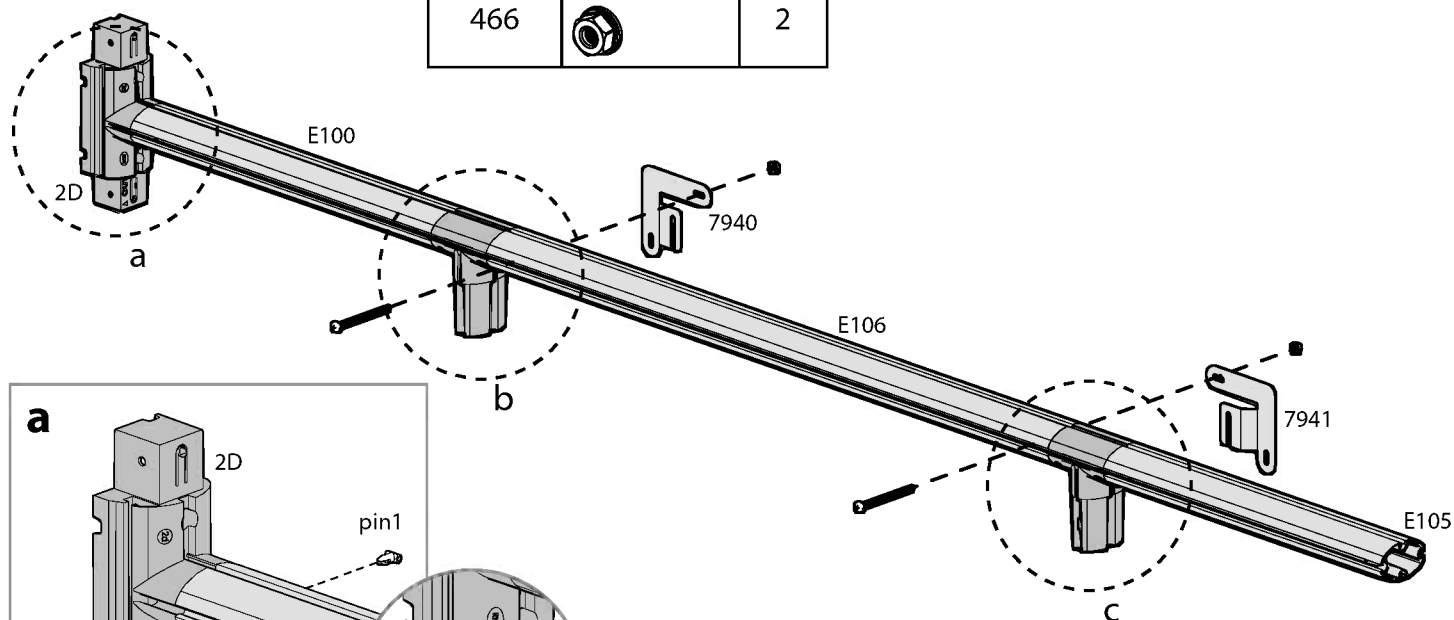
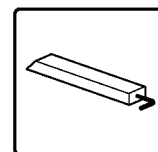
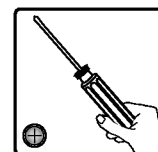

Item		Qty.
E106		1
E105		1
E100		1
2D		1
09		2

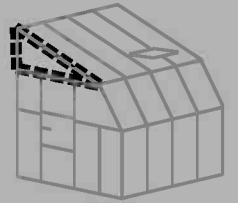
Item		Qty.
pin1		6
7941		1
7940		1
7224		2
466		2



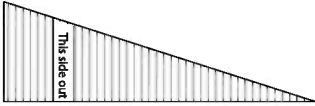

Item		Qty.
71		1
7801		1
pin1		6

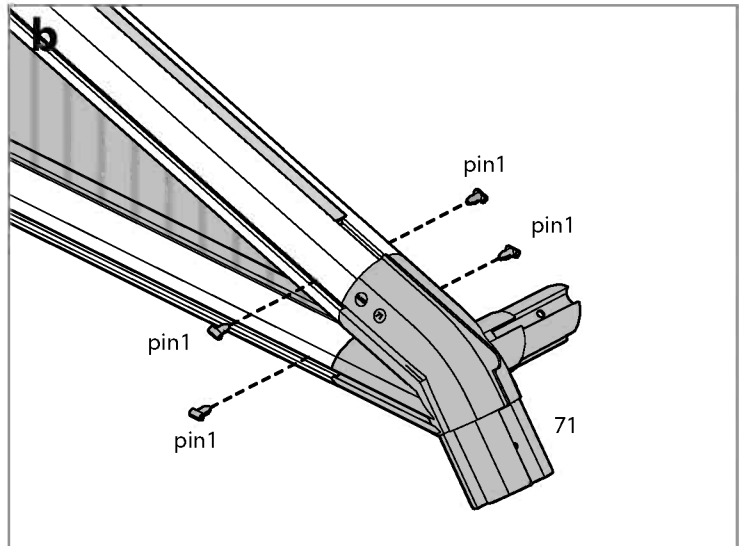
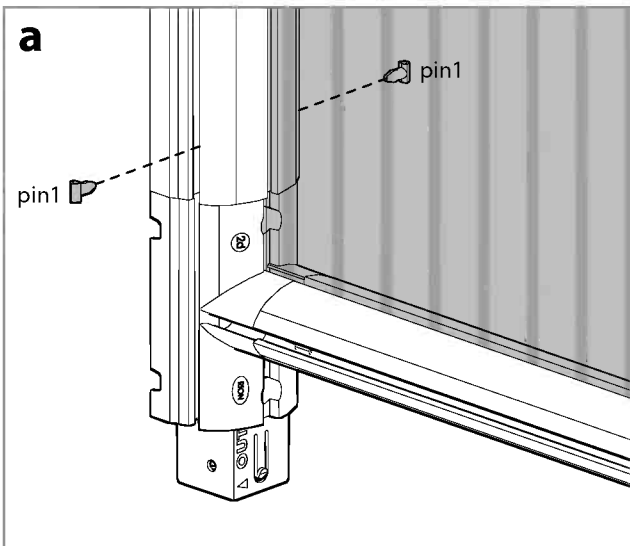
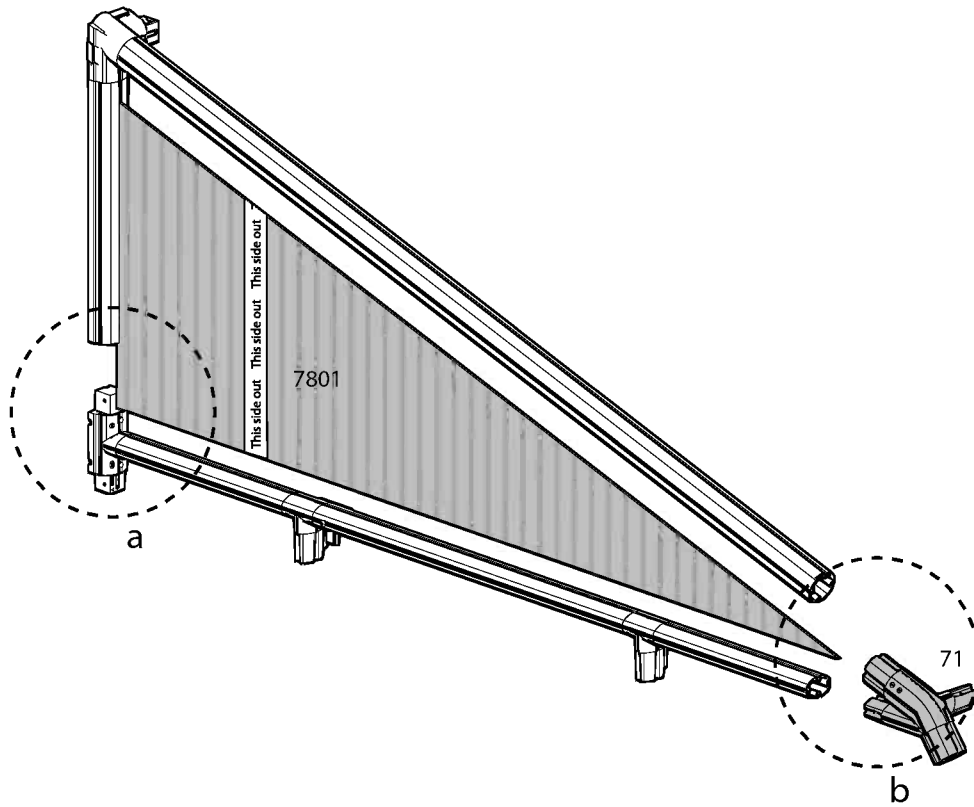
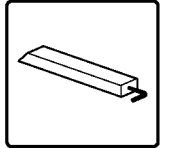

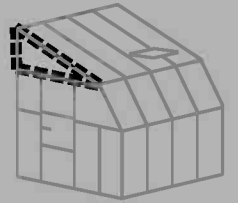

Item		Qty.
pin1		4
7224		2
466		2

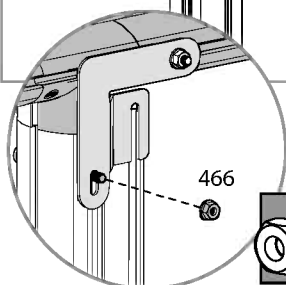
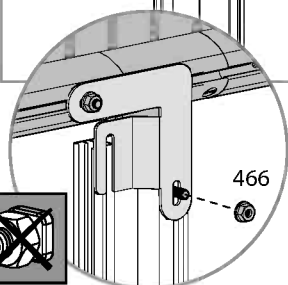
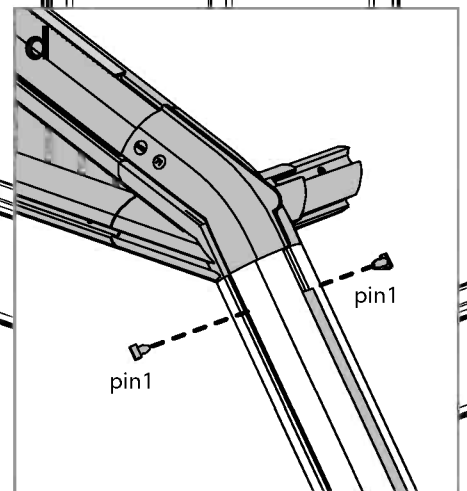
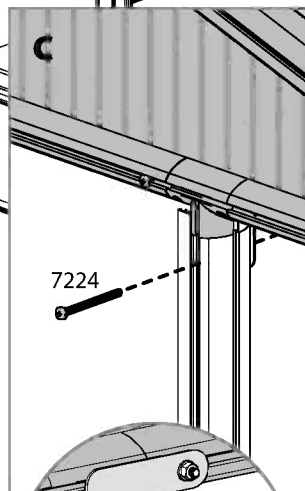
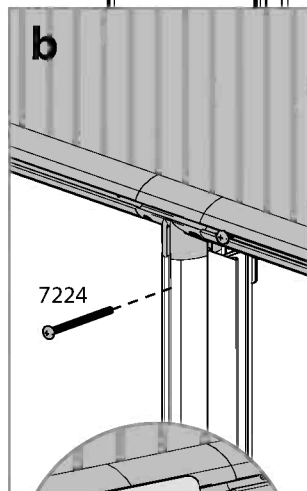
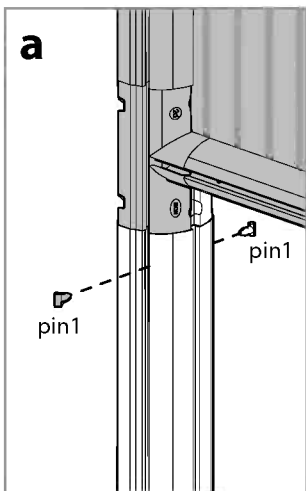
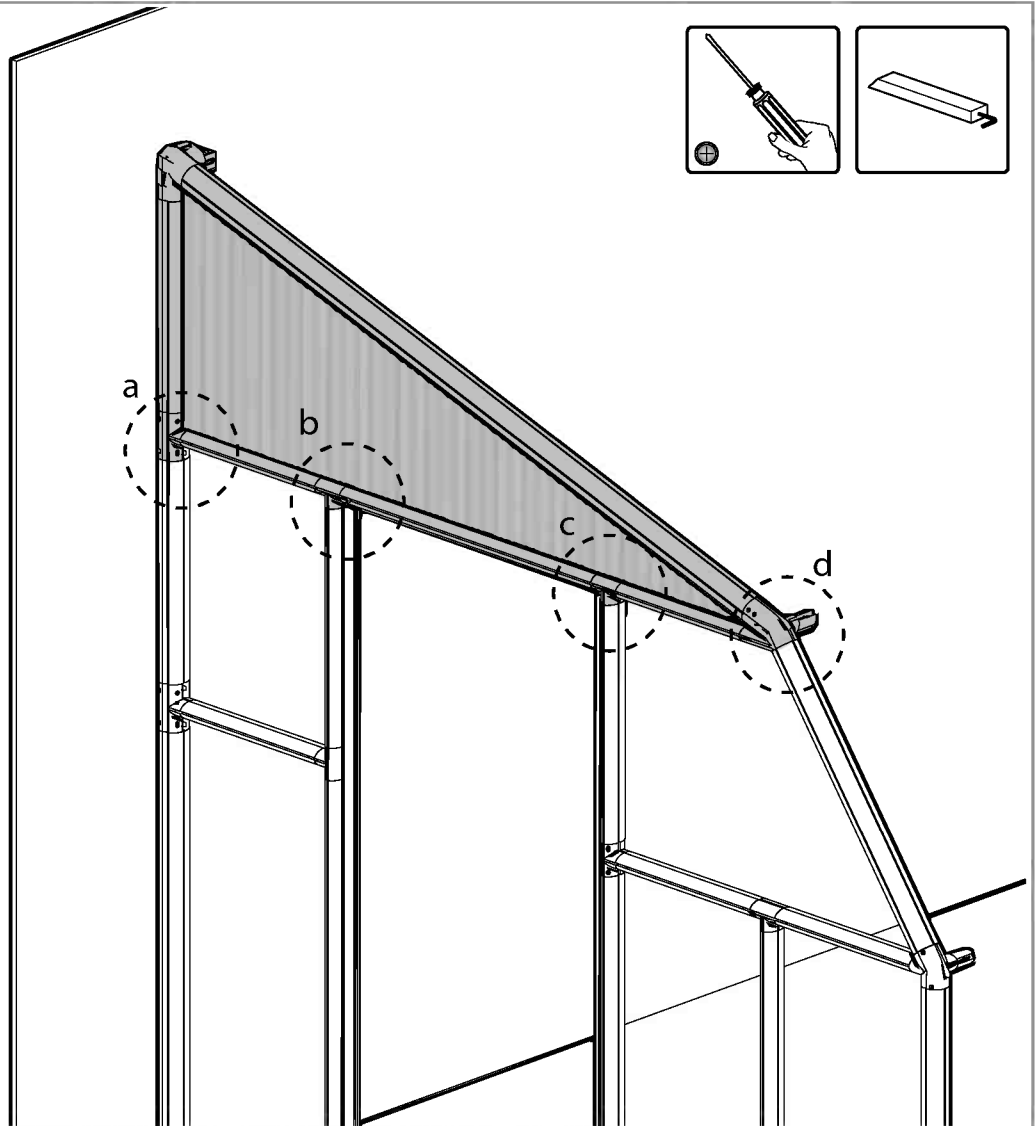
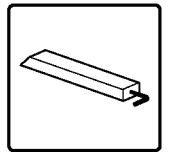
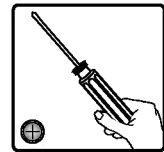

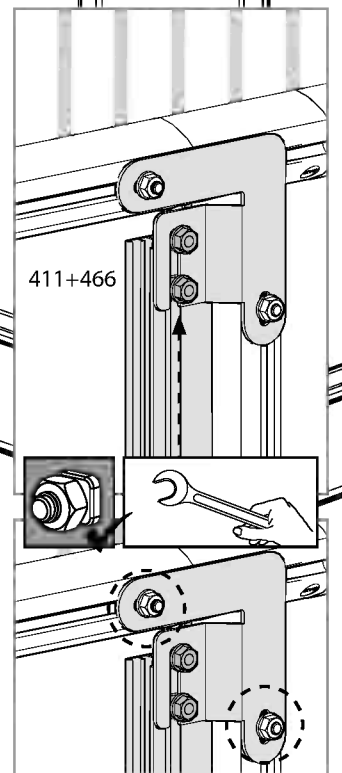
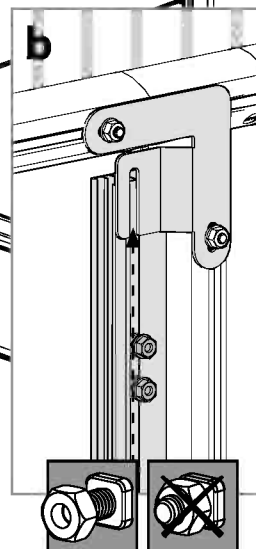
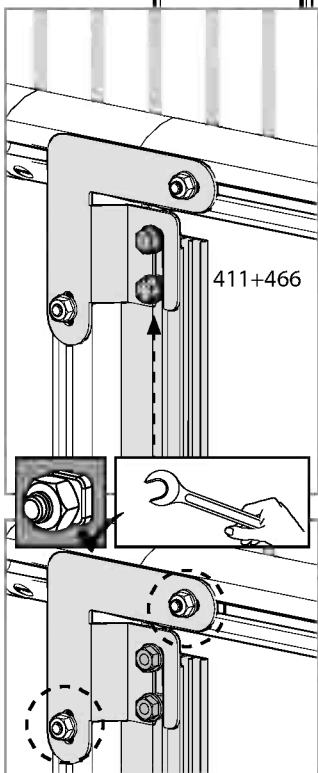
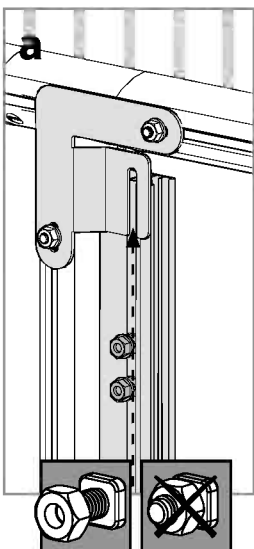
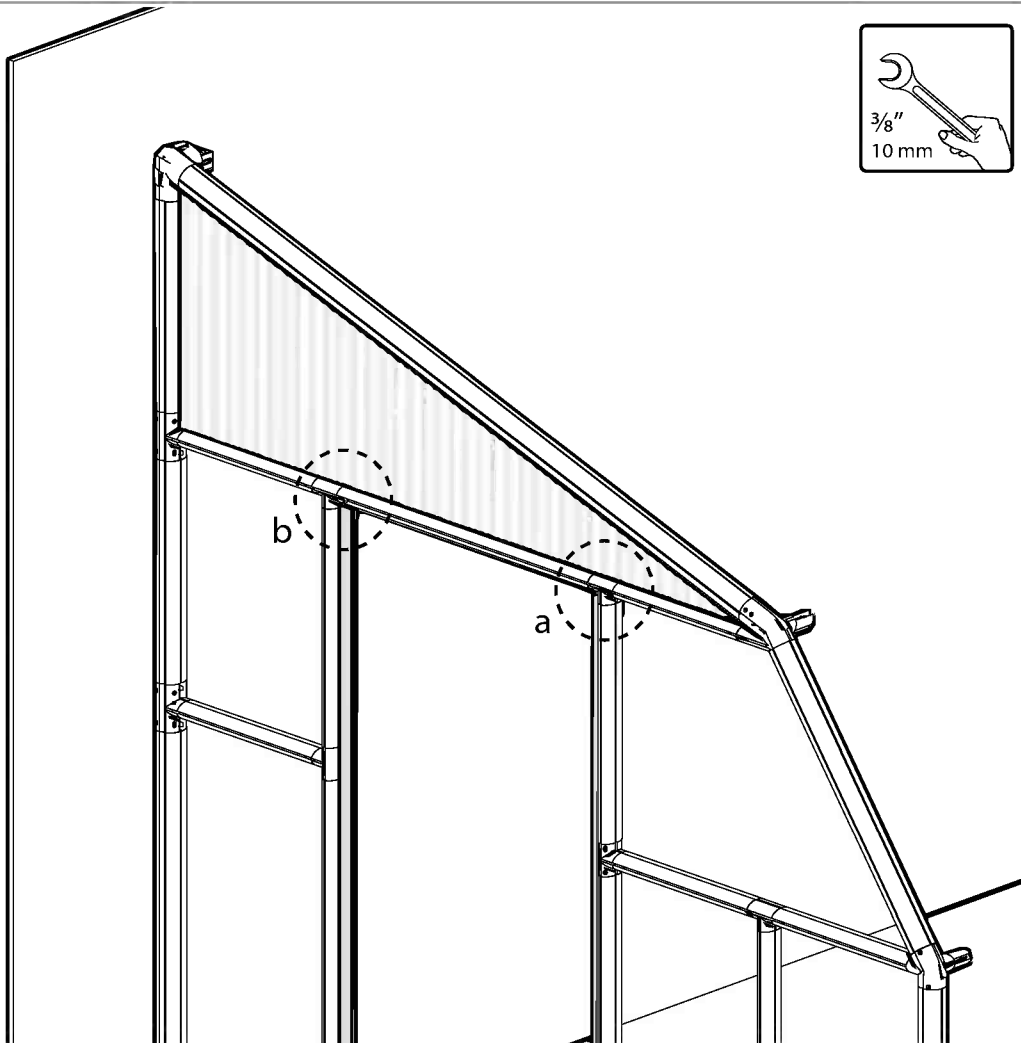
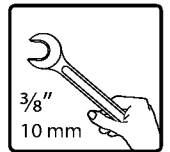
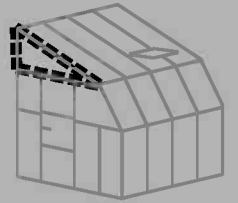

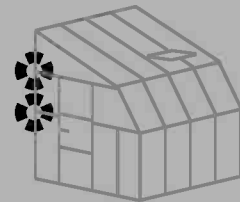



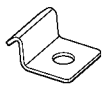

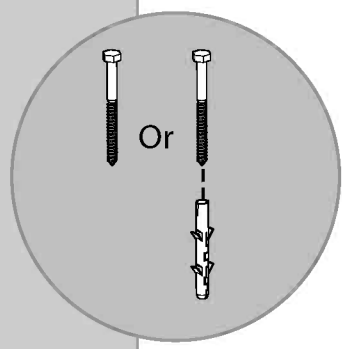
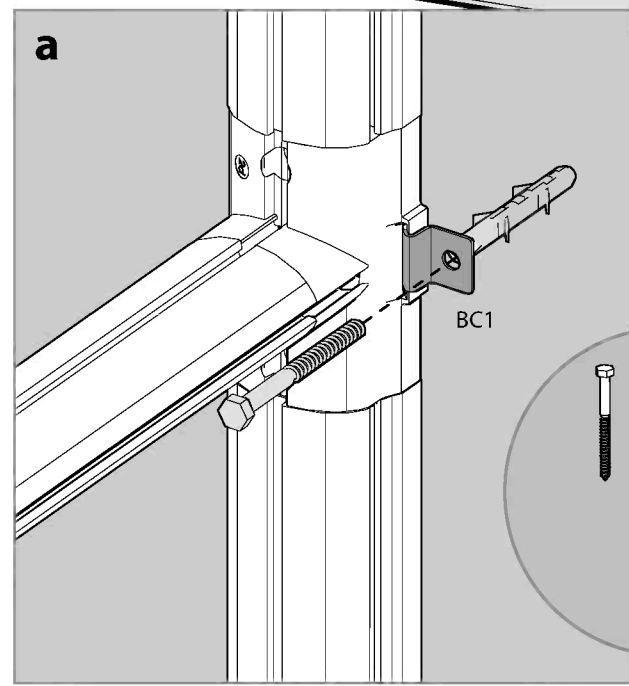
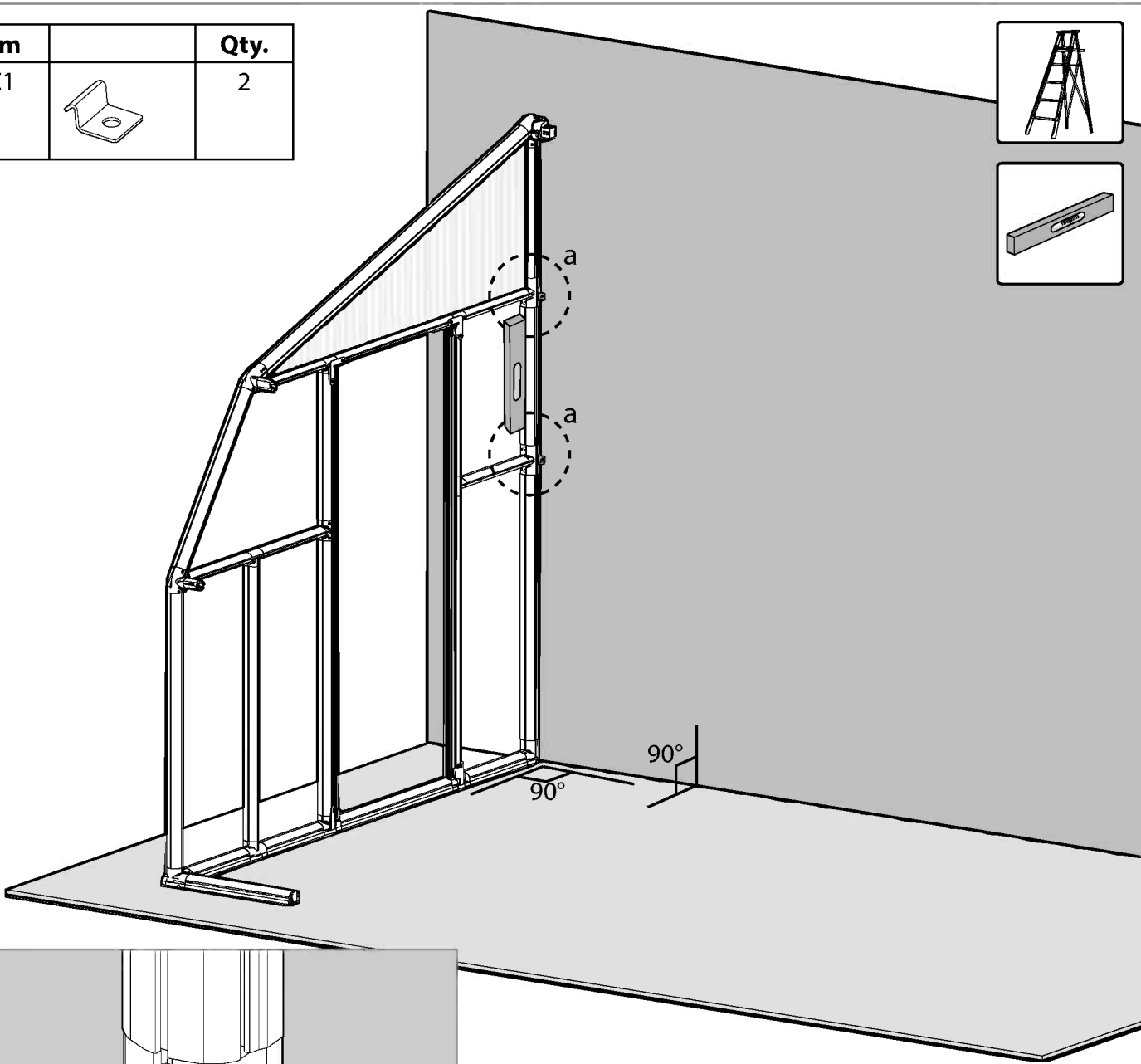
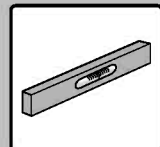
17 

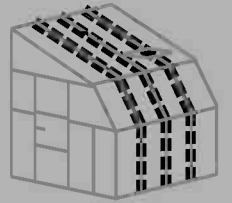
Item		Qty.
BC1		2

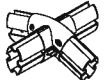
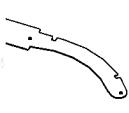





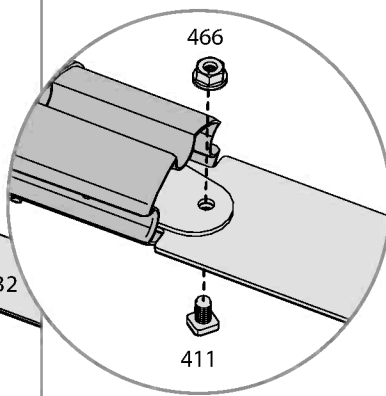
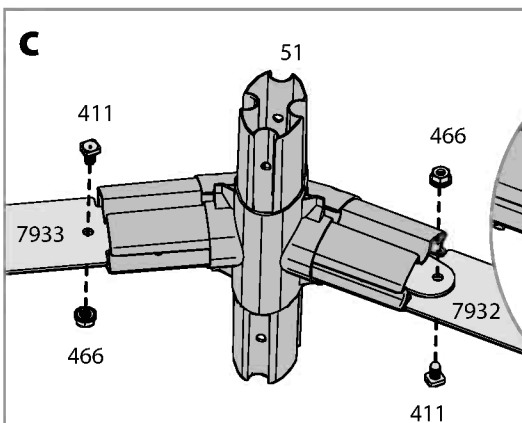
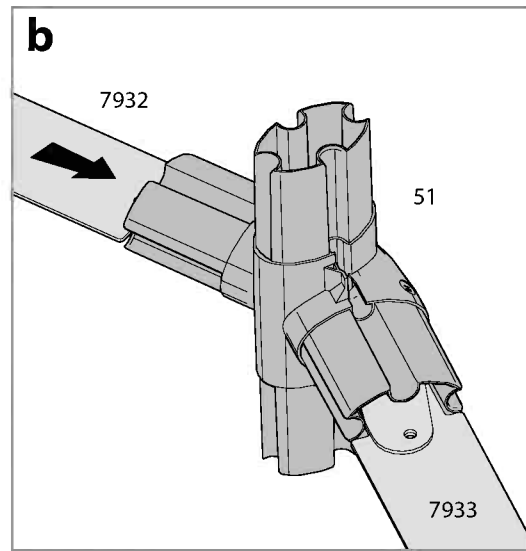
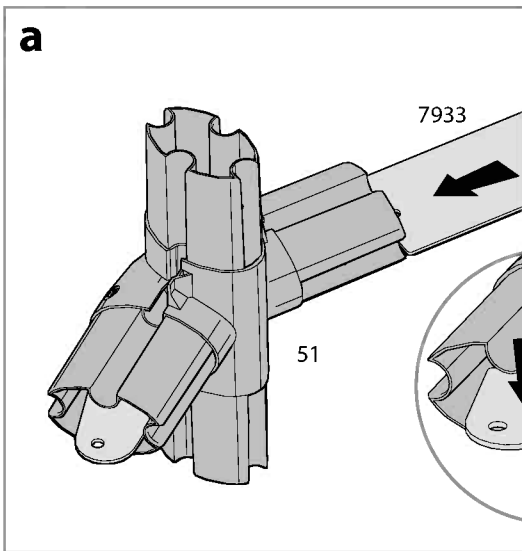
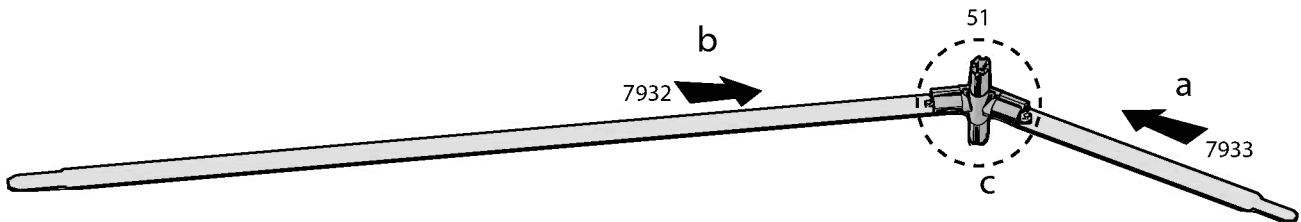
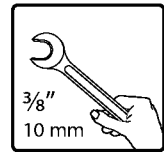
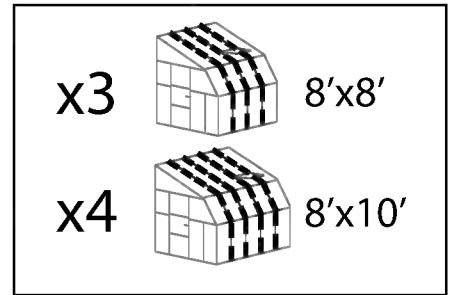

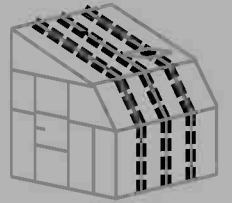
Item		Qty.
51		1
7932		1
7933		1
411		2
466		2





Item		Qty.
pin1		2
E15		1
7608		1

x3  8'x8'

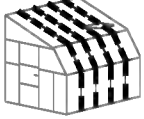
x4  8'x10'

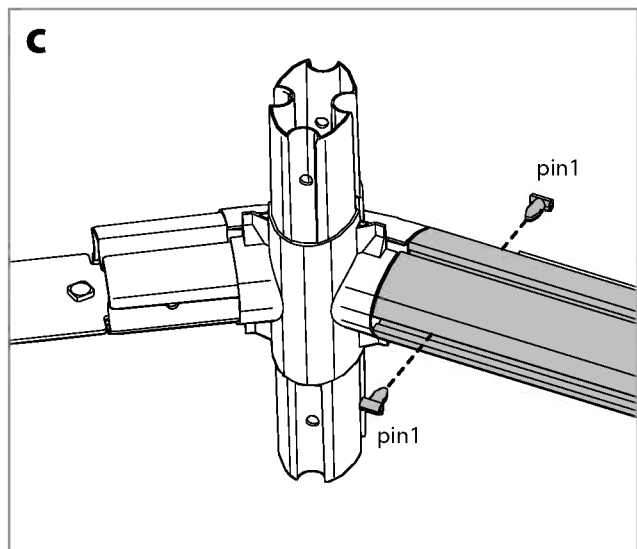
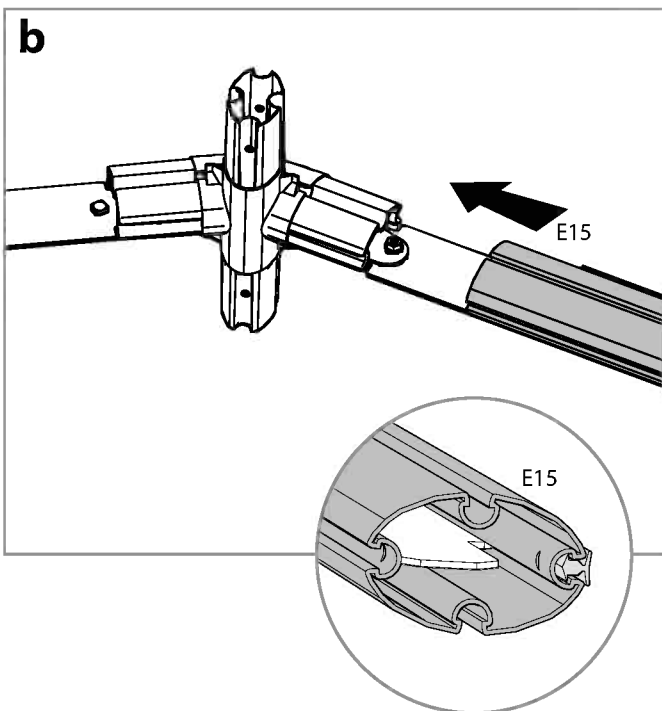
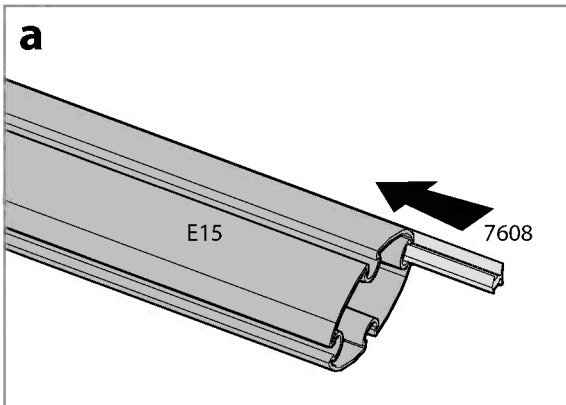
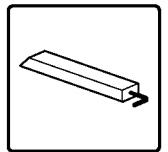

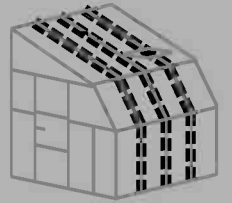



Item		Qty.
51		1
7935		1
7934		1
411		2
466		2

x3 8'x8'

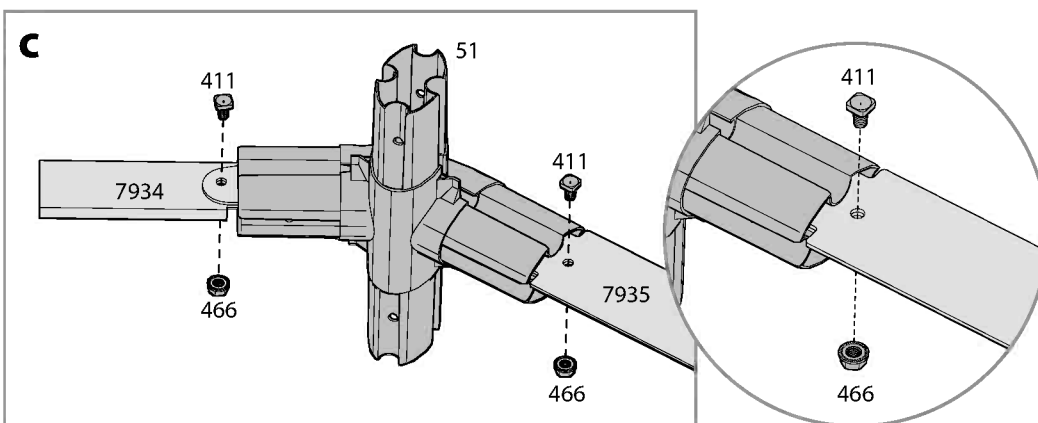
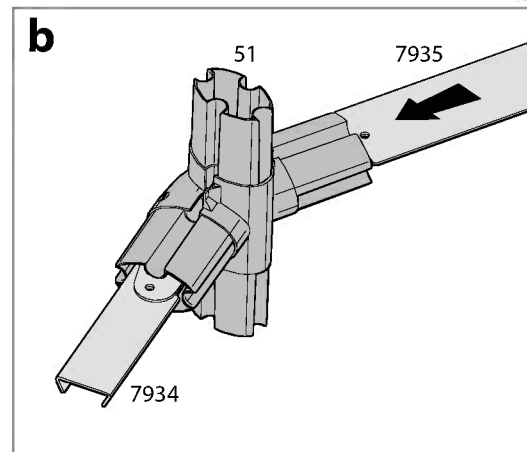
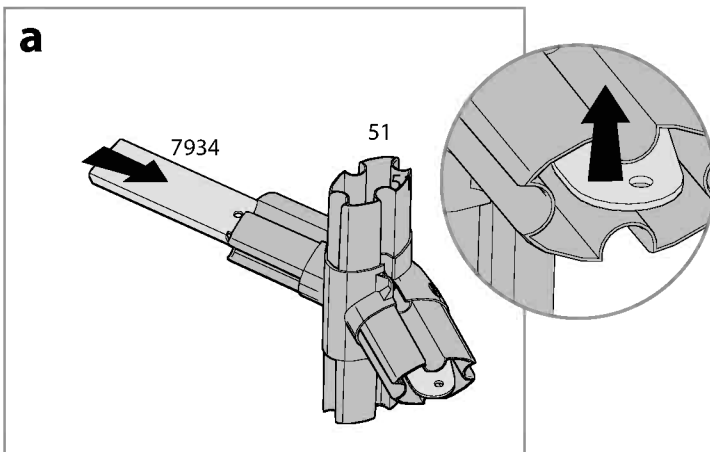
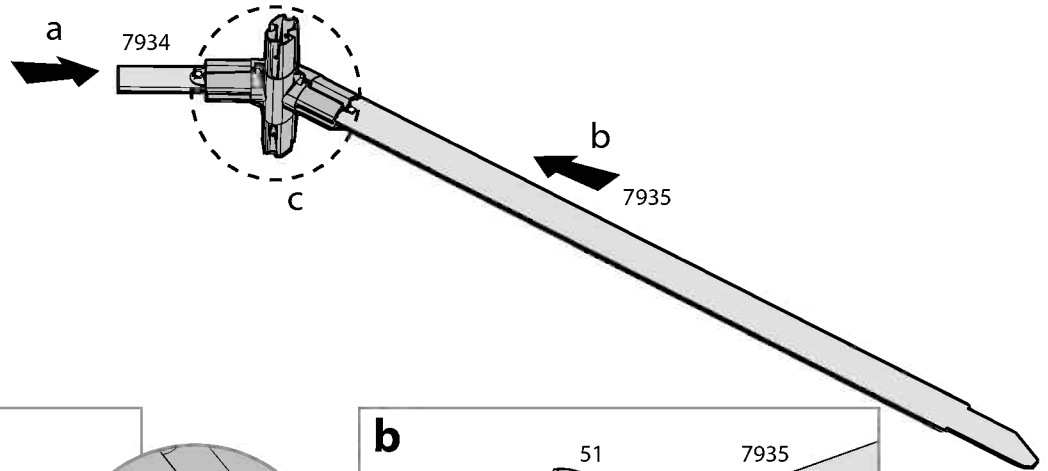
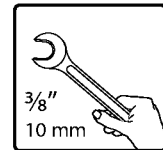
x4 8'x10'

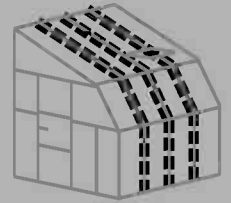



Item		Qty.
pin1		2

x3  8'x8'

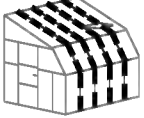
x4  8'x10'

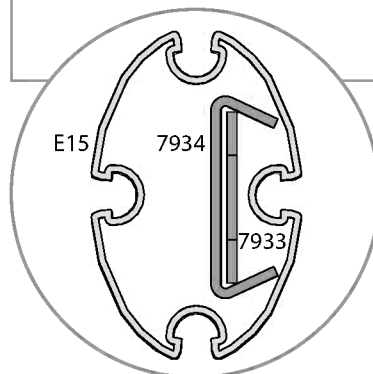
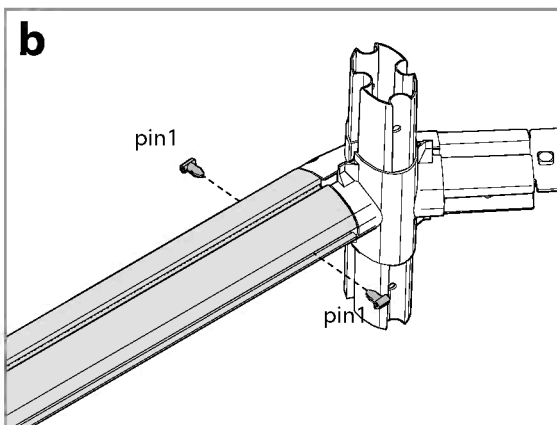
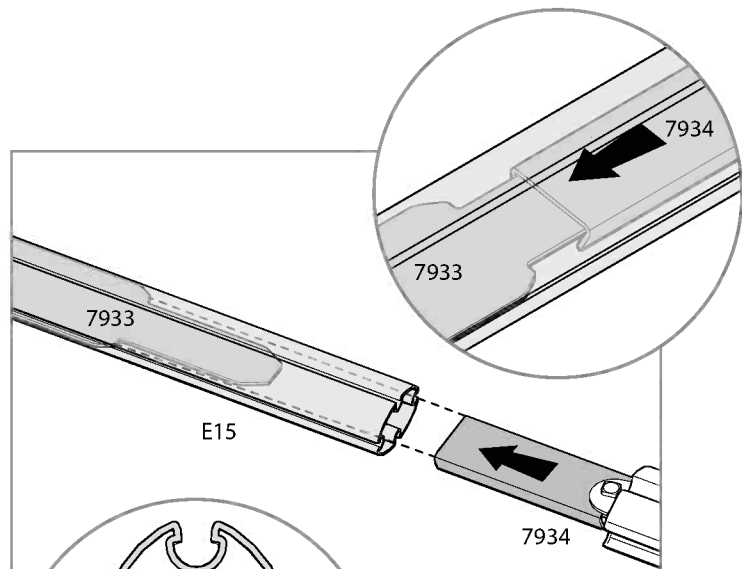
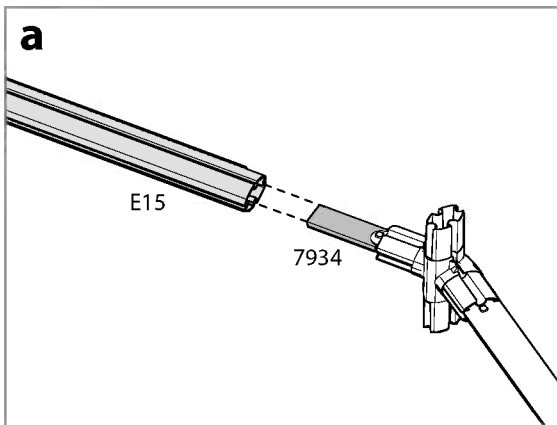
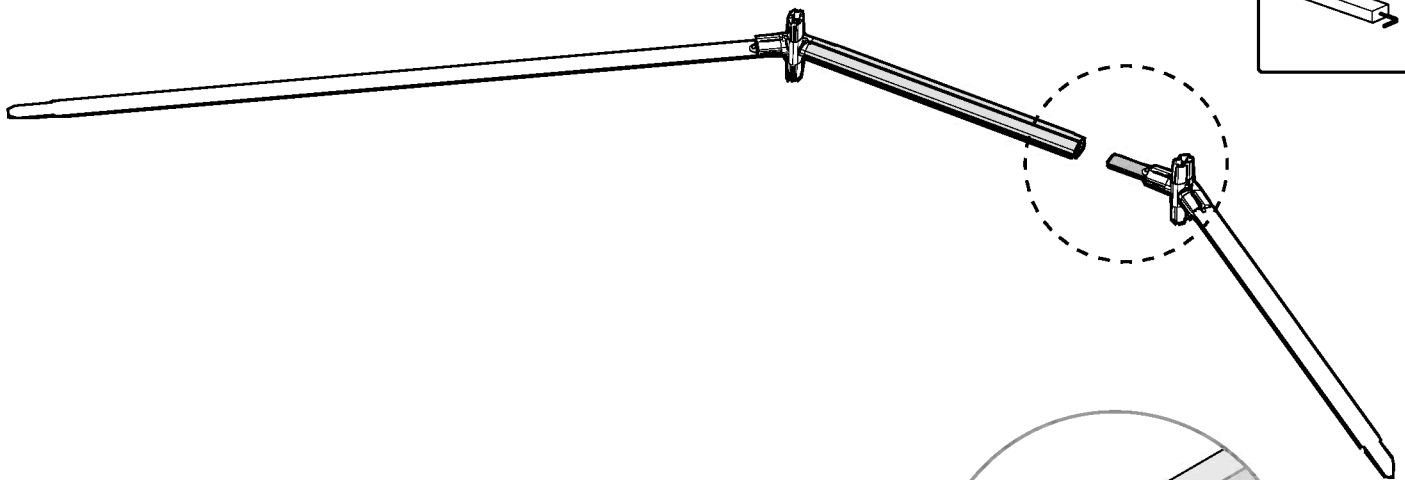
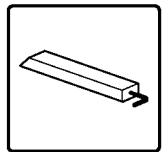

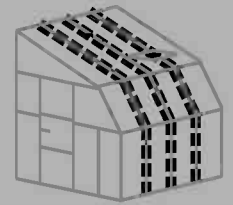



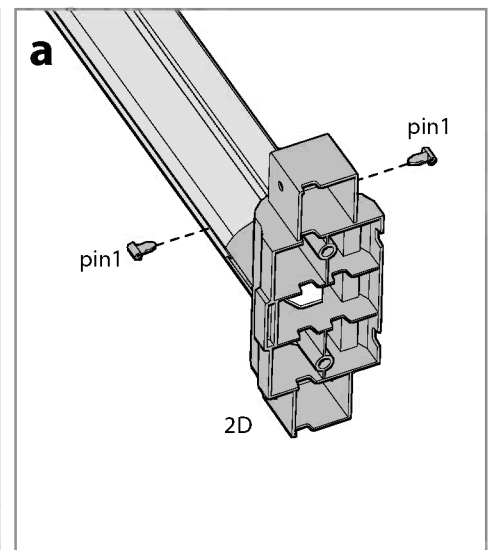
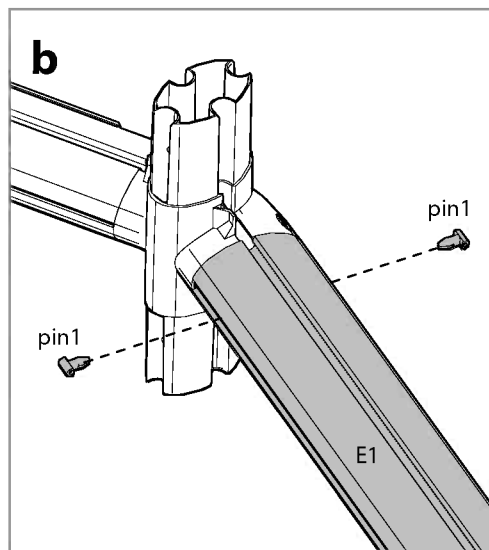
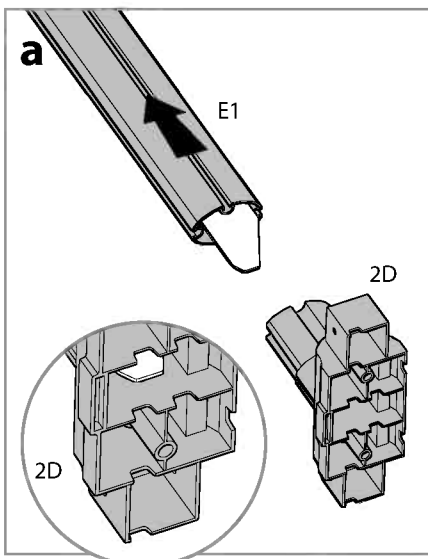
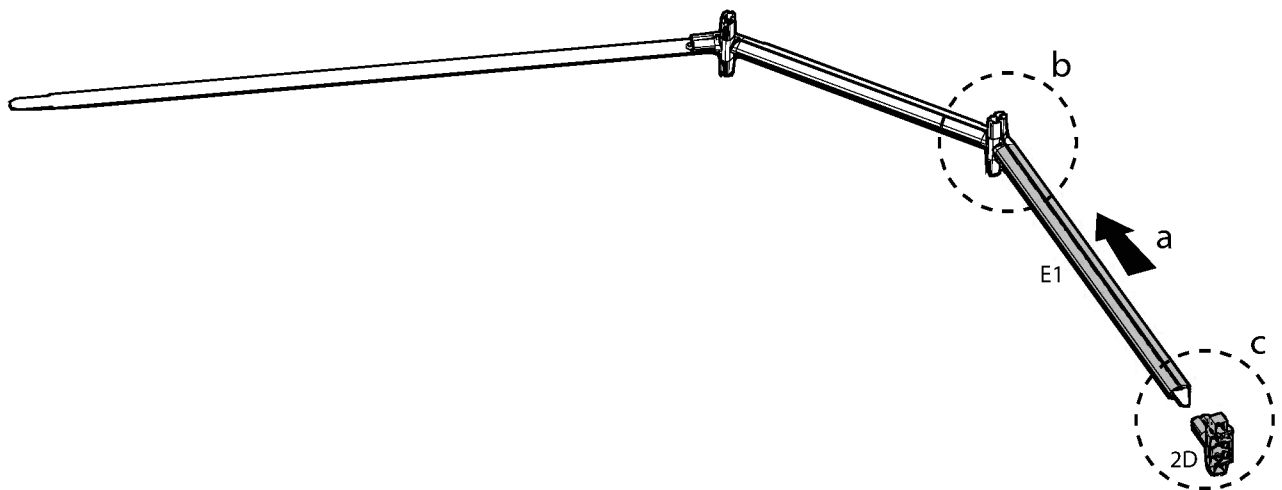
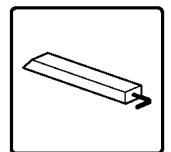

Item		Qty.
2D		1
E1		1
pin1		4

x3 8'x8'

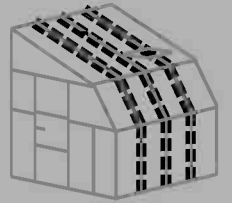
x4 8'x10'

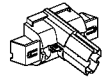





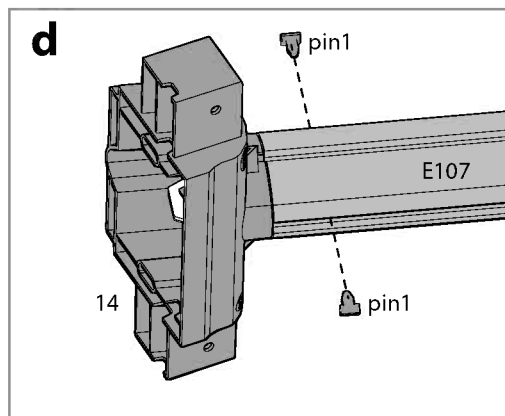
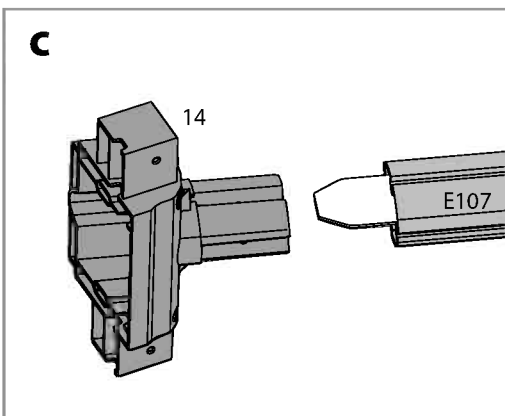
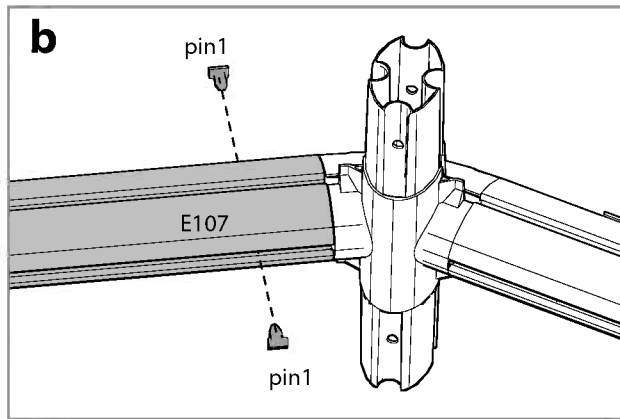
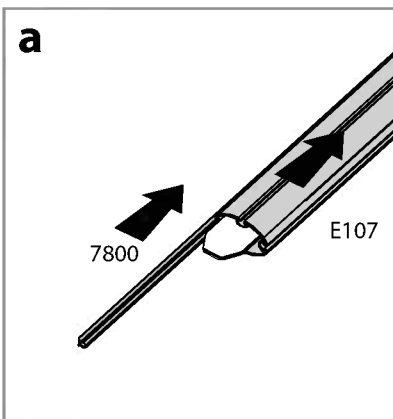
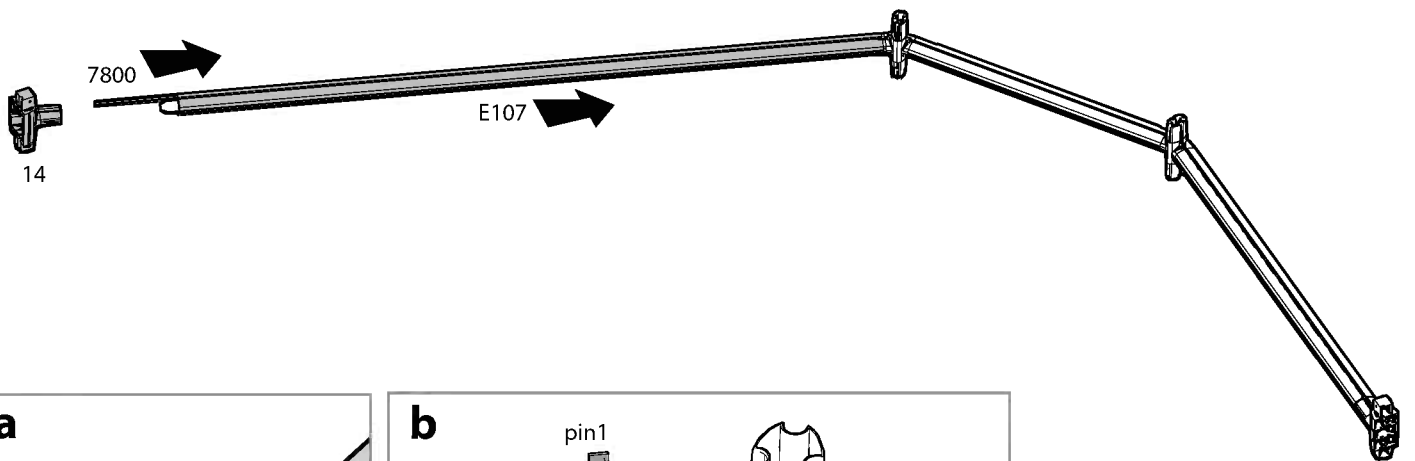
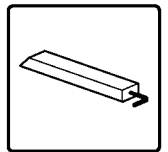

Item		Qty.
14		1
E107		1
7800		1
pin1		4

x3  8'x8'

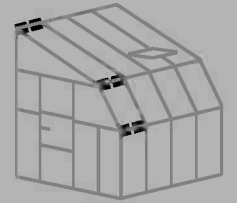
x4  8'x10'





Item		Qty.
pin1		6
E2		2
B2		1

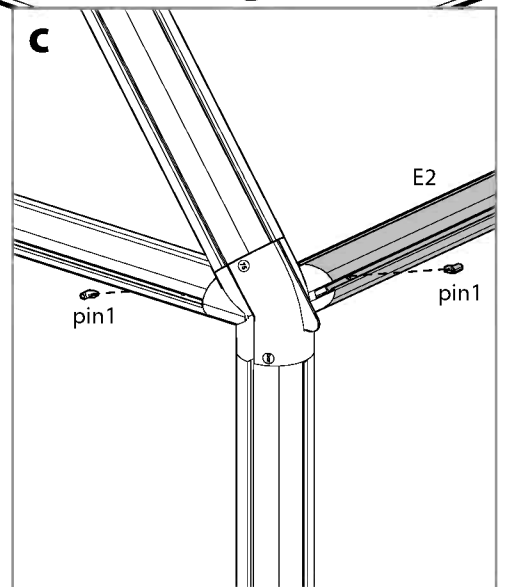
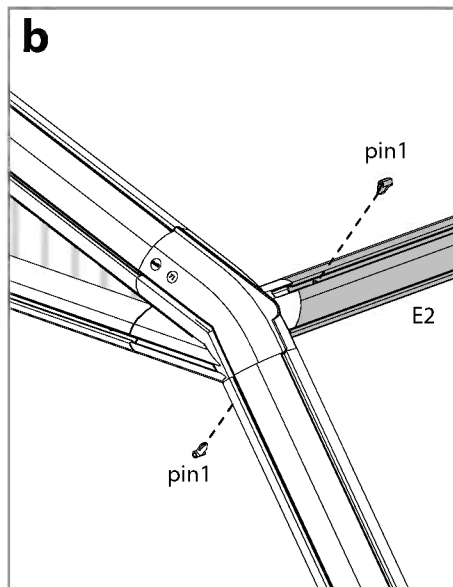
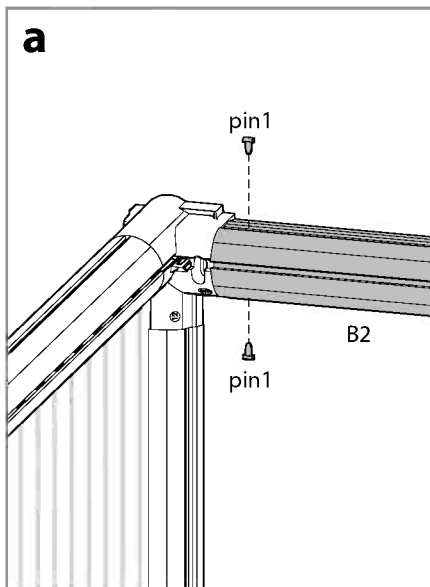
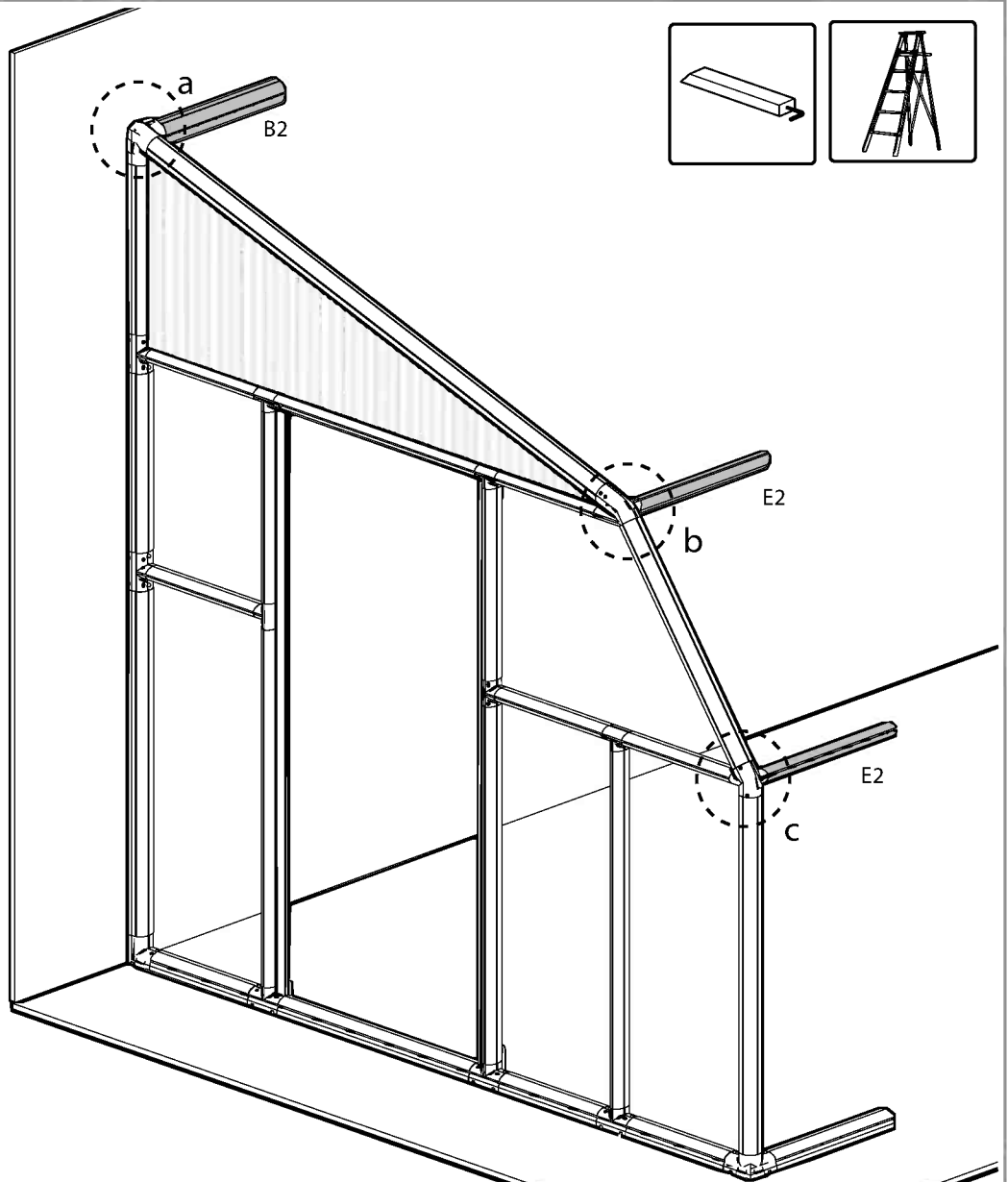

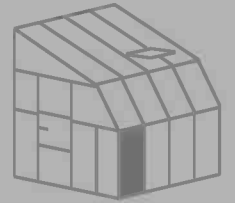

Item		Qty.
PN1		1

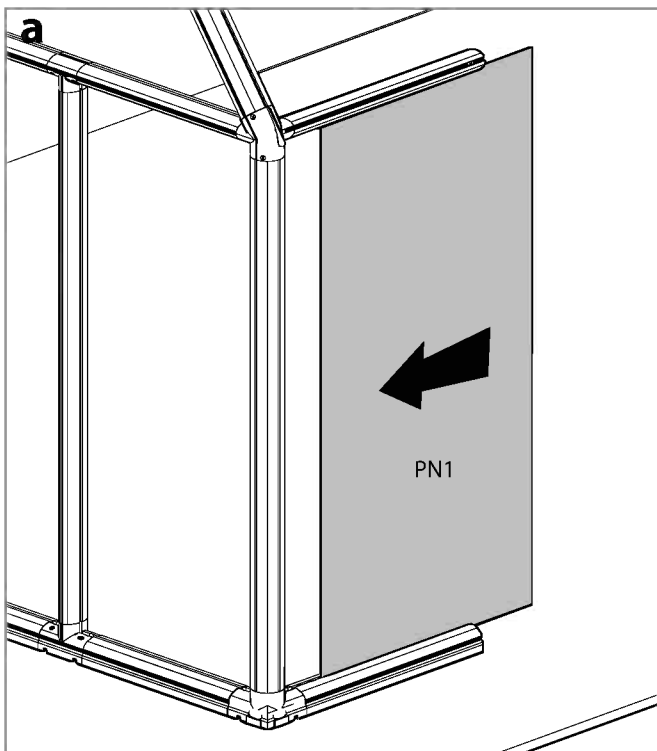
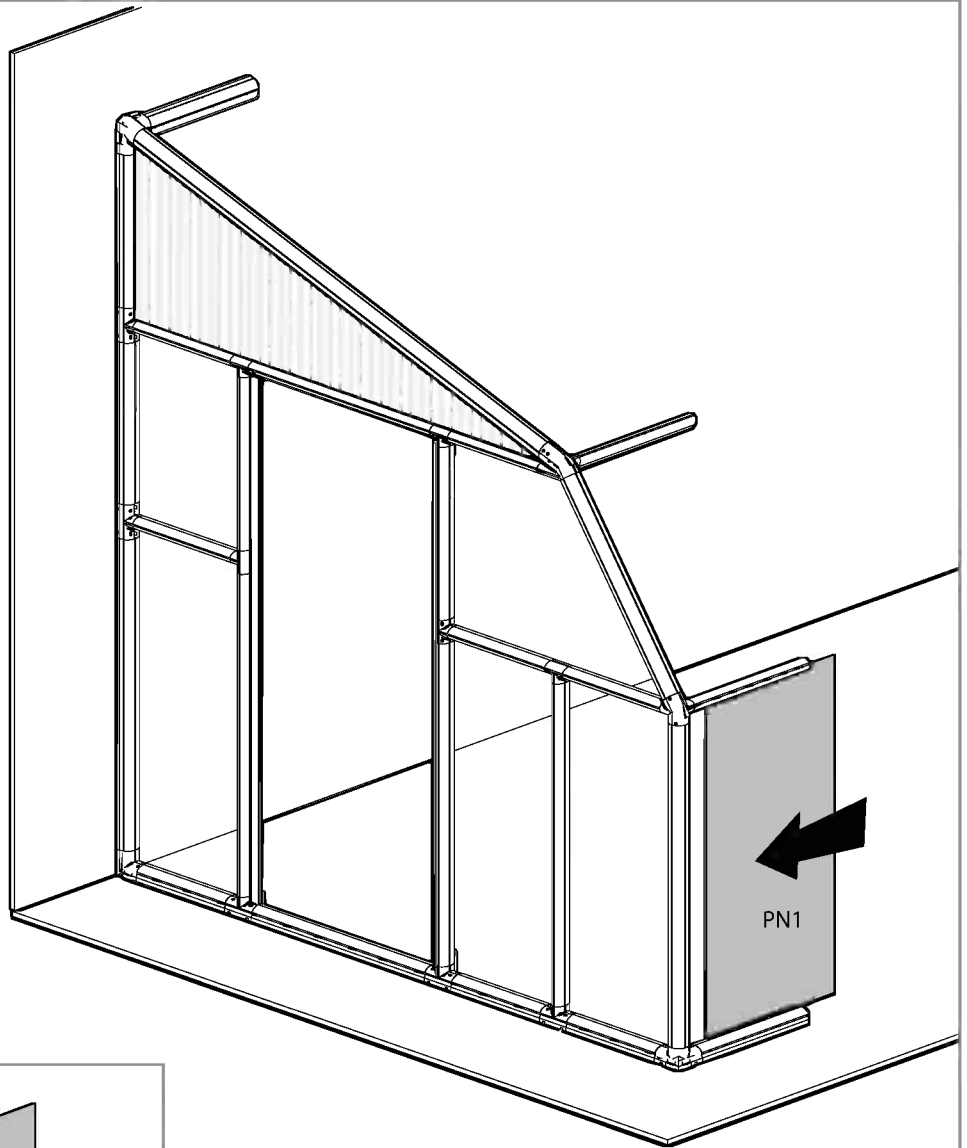

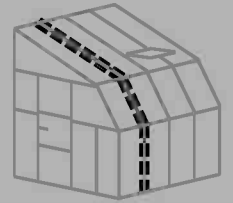

Item		Qty.
pin1		8

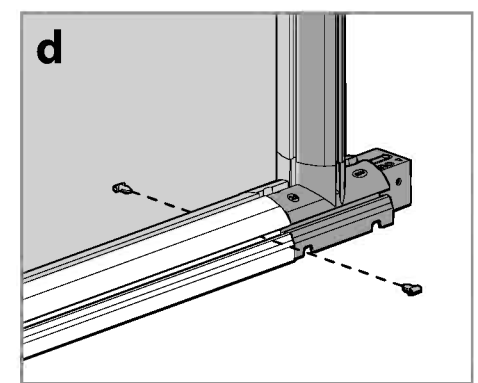
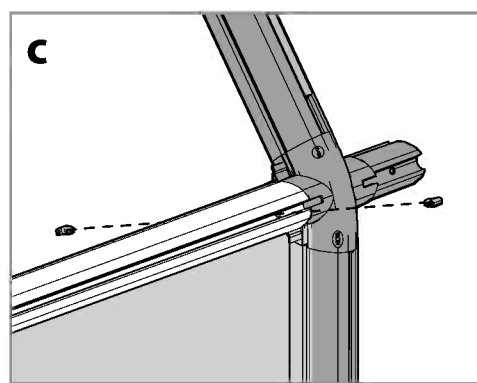
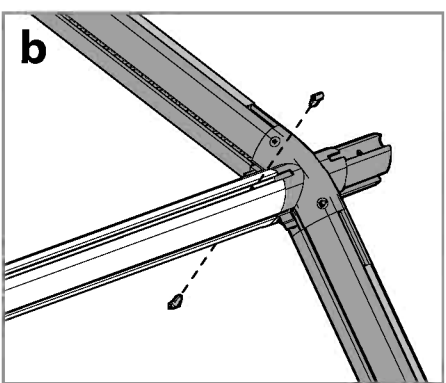
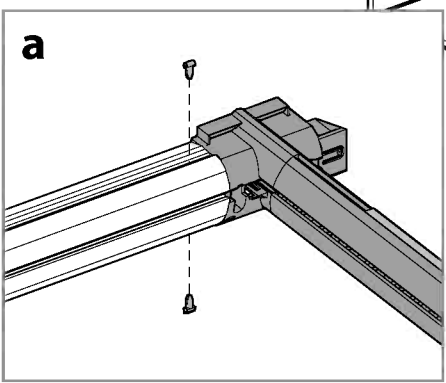
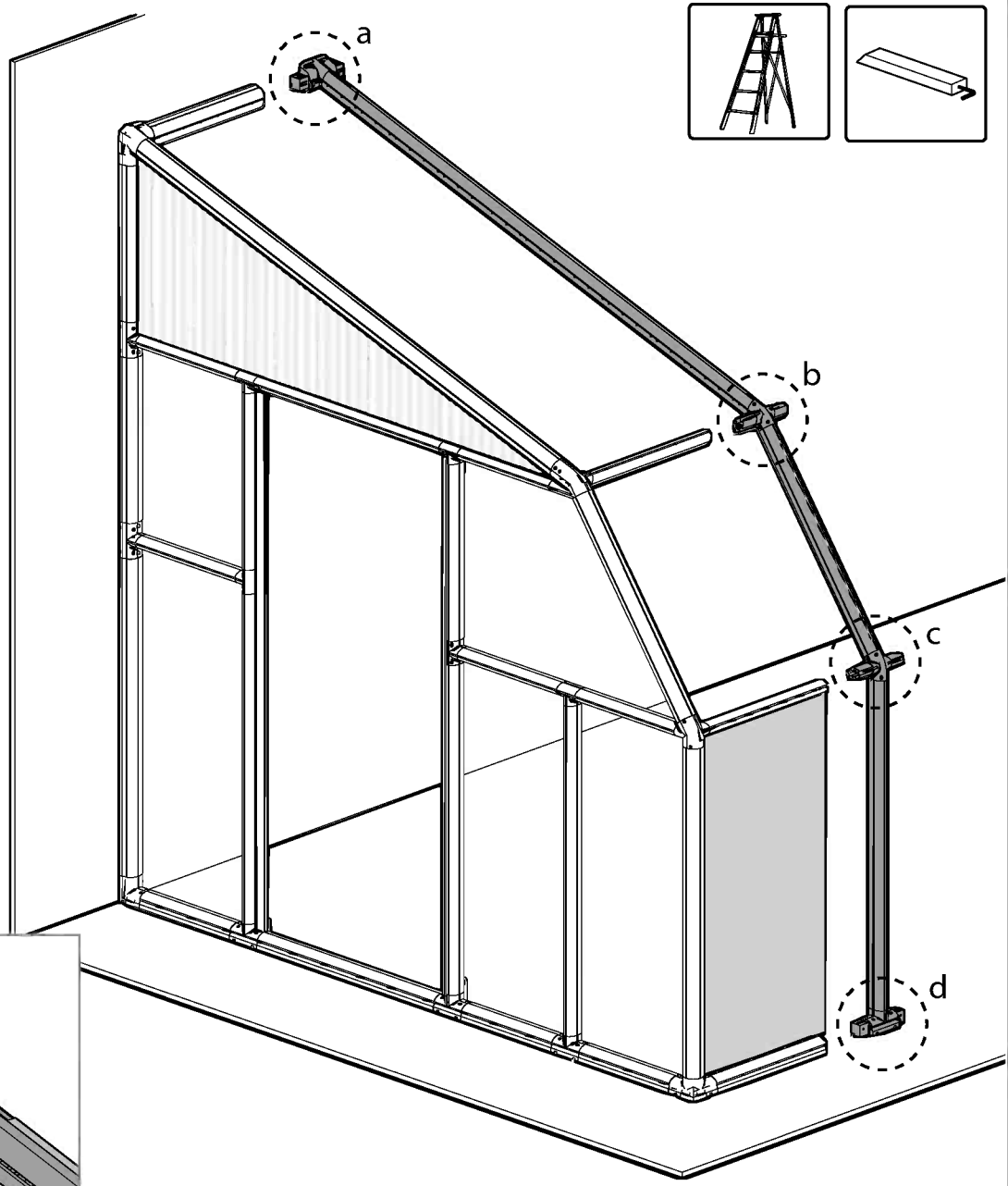
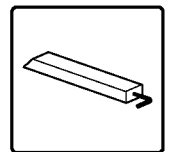

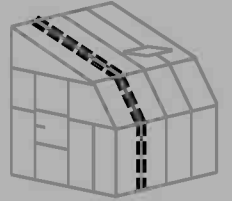

Item		Qty.
7937		1

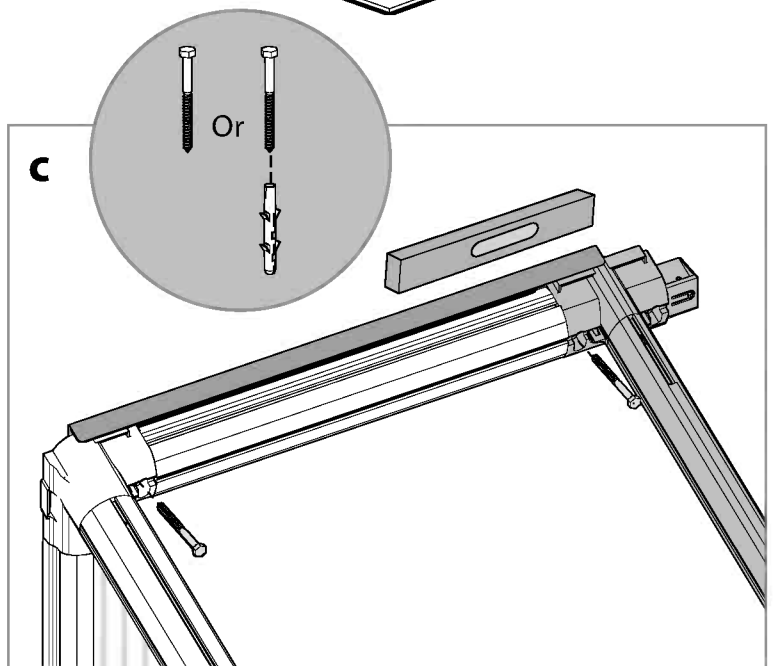
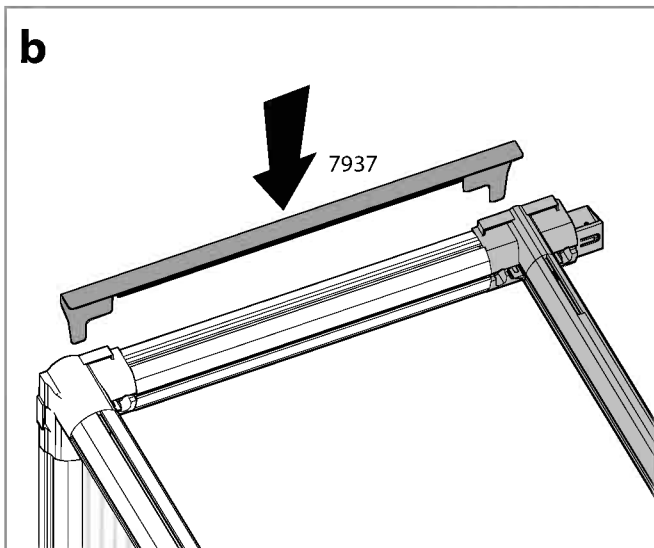
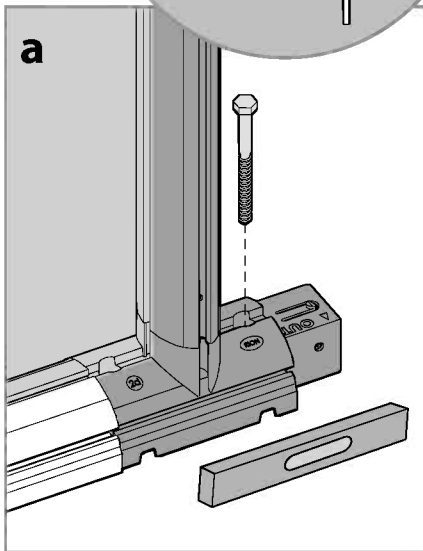
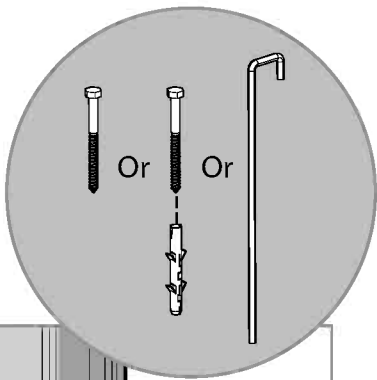
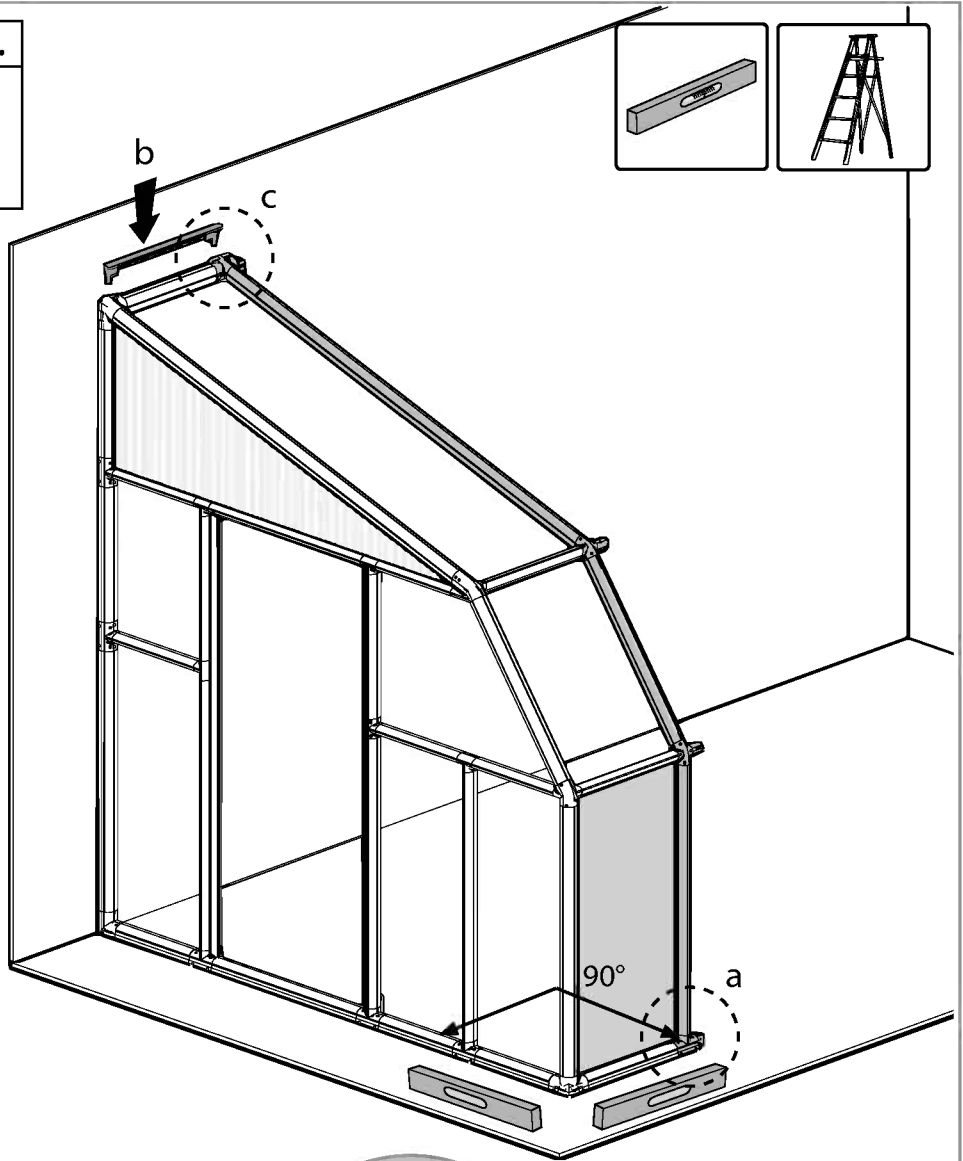
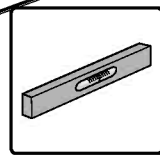

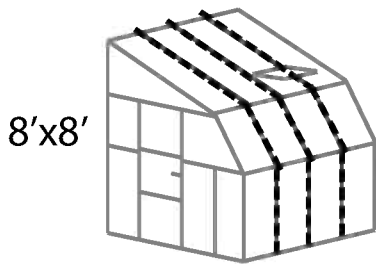
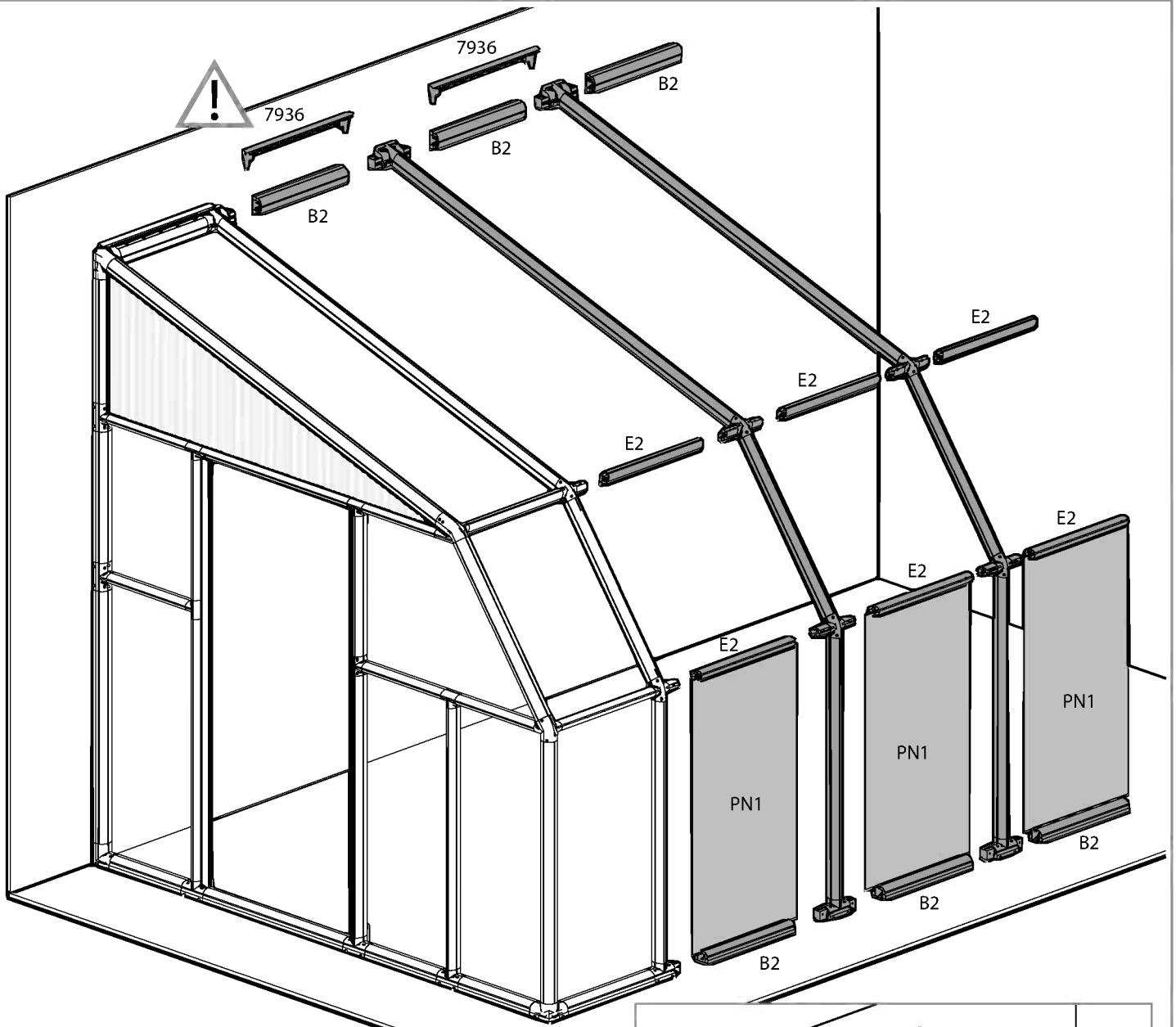
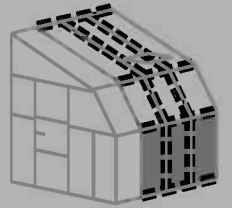

Item	Qty.
PN1	3
B2	6
E2	6
7936	2
pin1	40

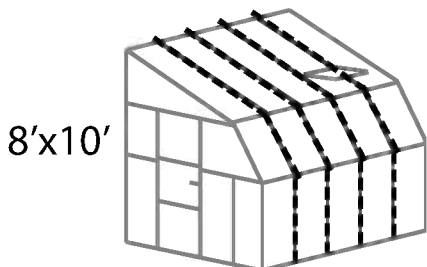

Item	Qty.
PN1	4
B2	8
E2	8
7936	3
pin1	56

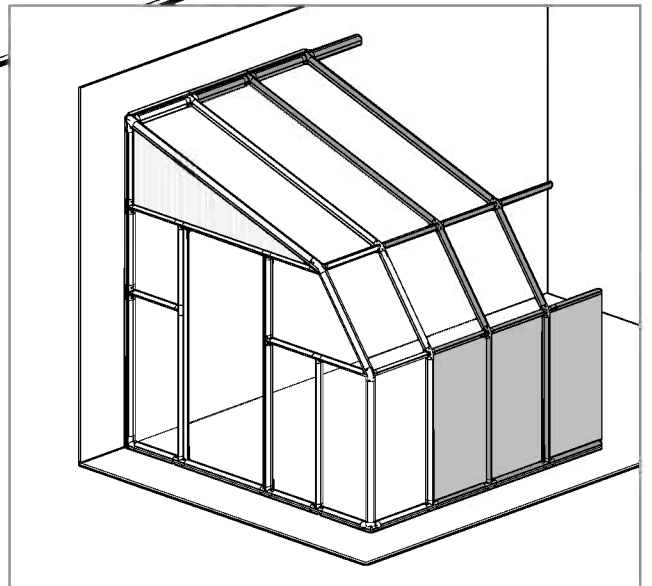

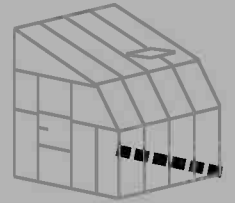

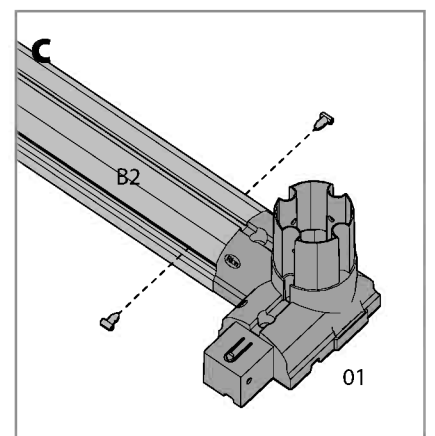
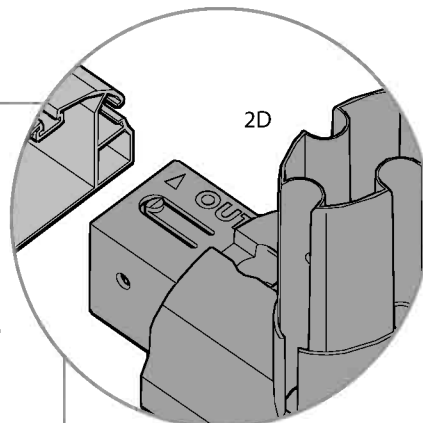
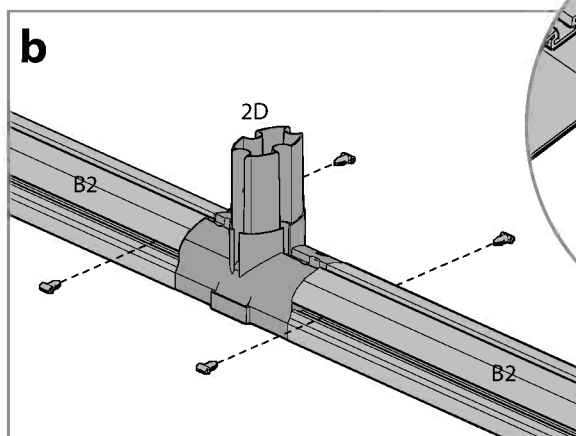
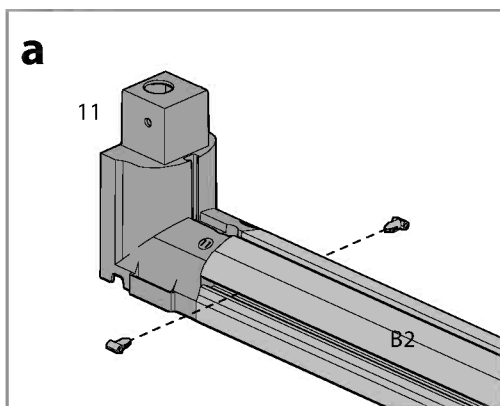
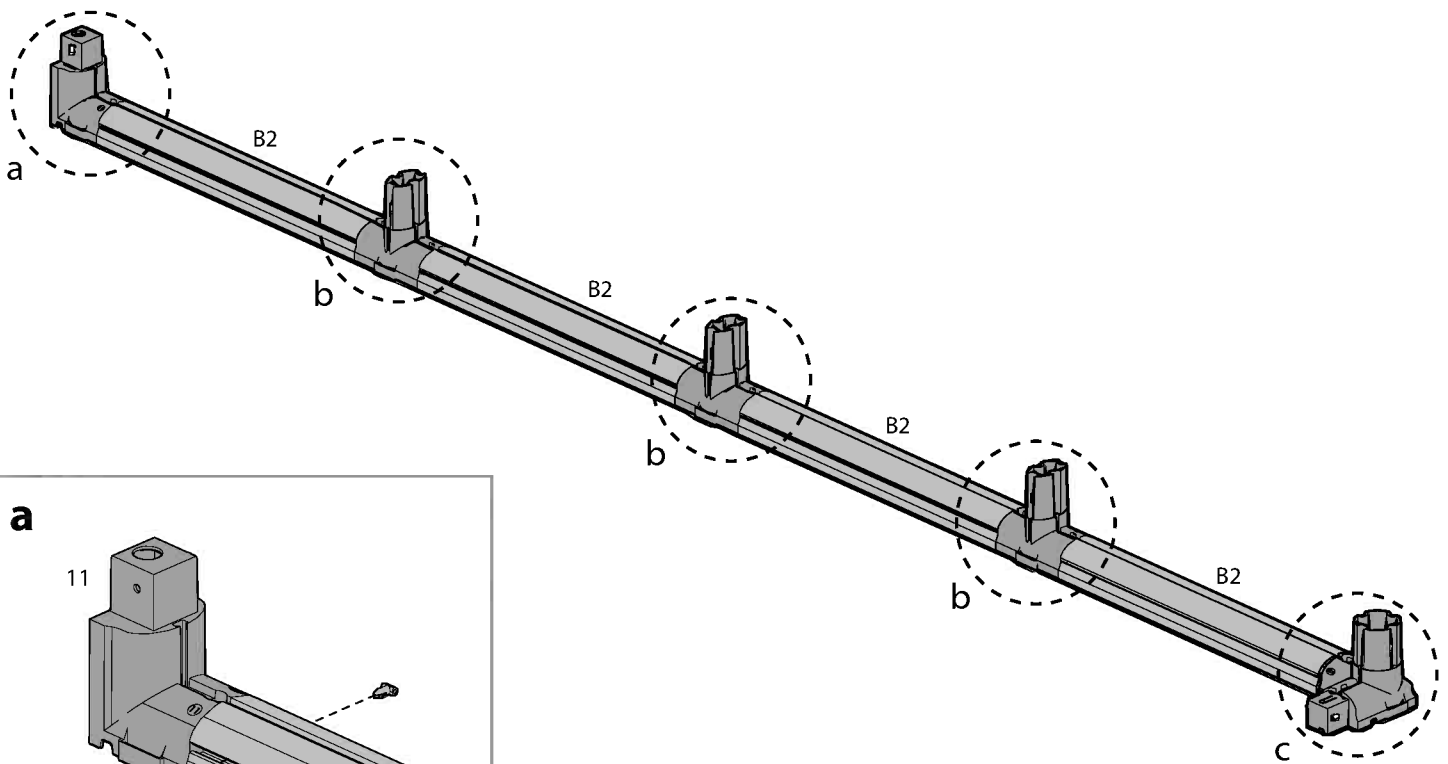
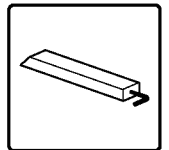

Item		Qty.
B2		4
11		1
01		1

Item		Qty.
2D		3
pin1		16

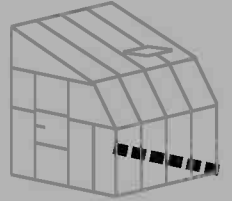

30 **i**



Item		Qty.
pin1		2

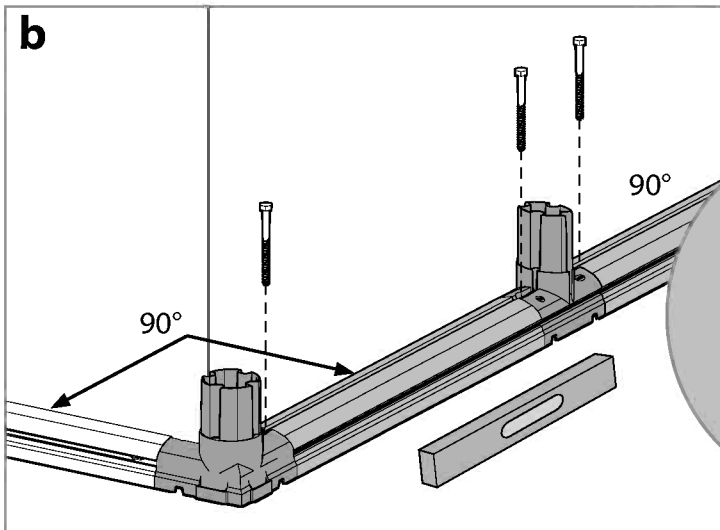
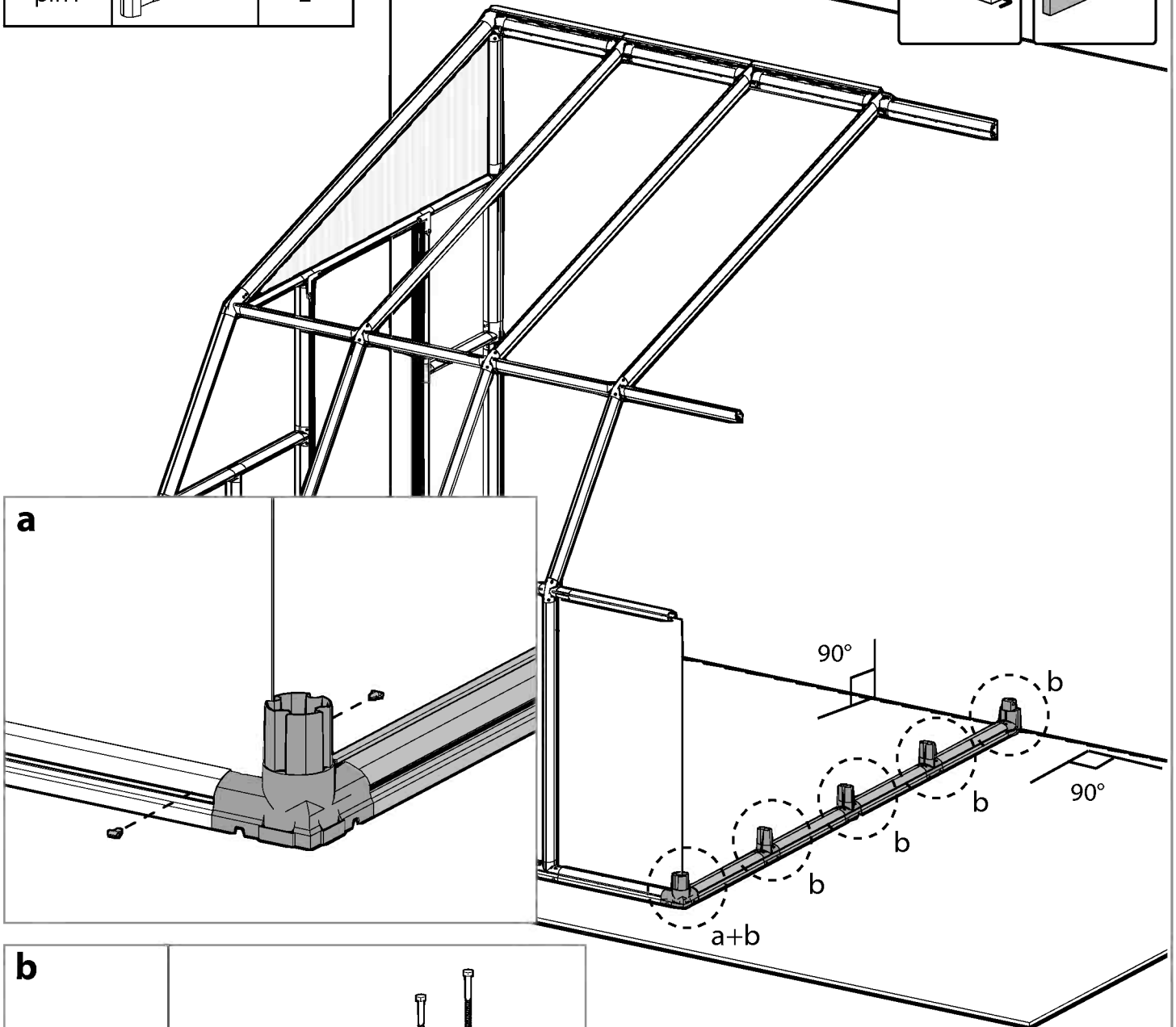
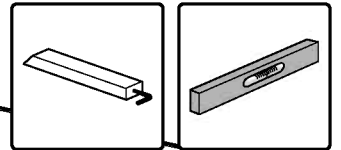

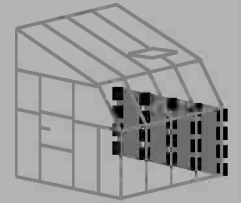

Item		Qty.
PN1		4
B1		1
E1		3
R1		1
pin1		10

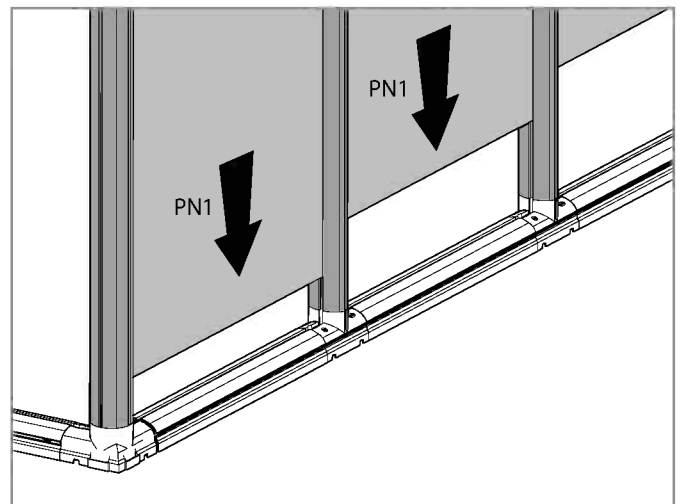
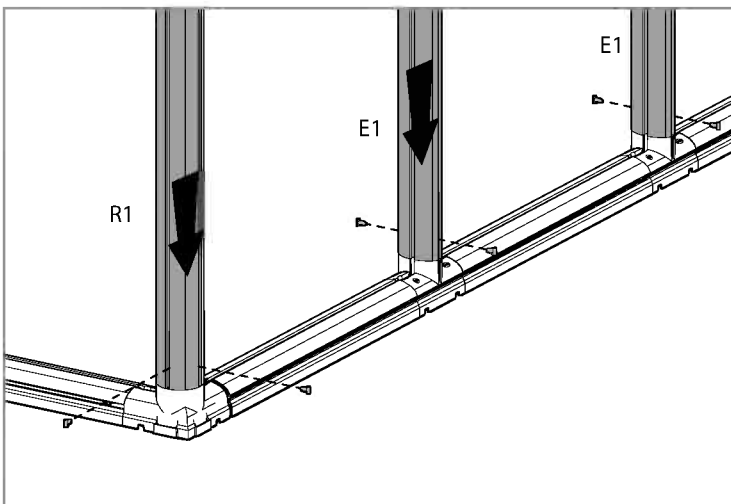
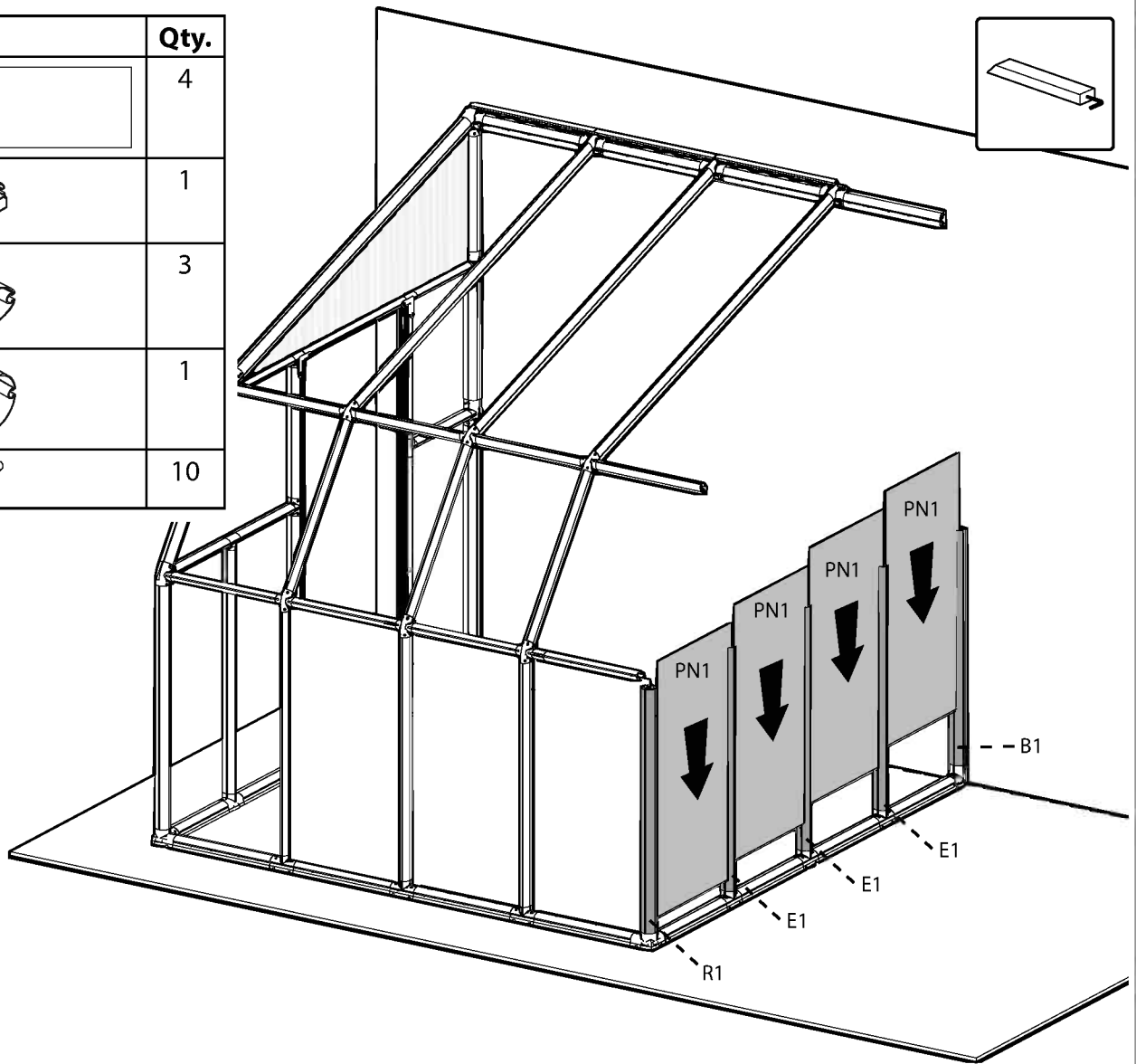

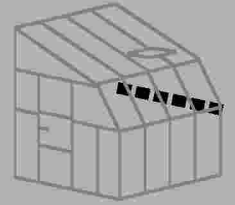

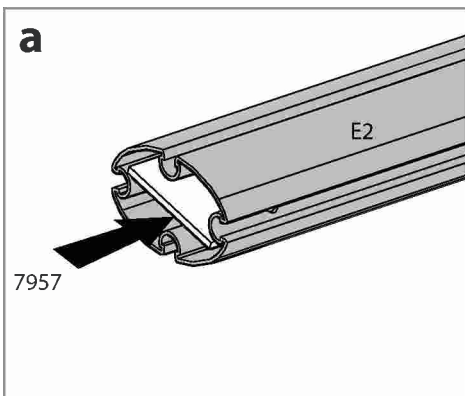
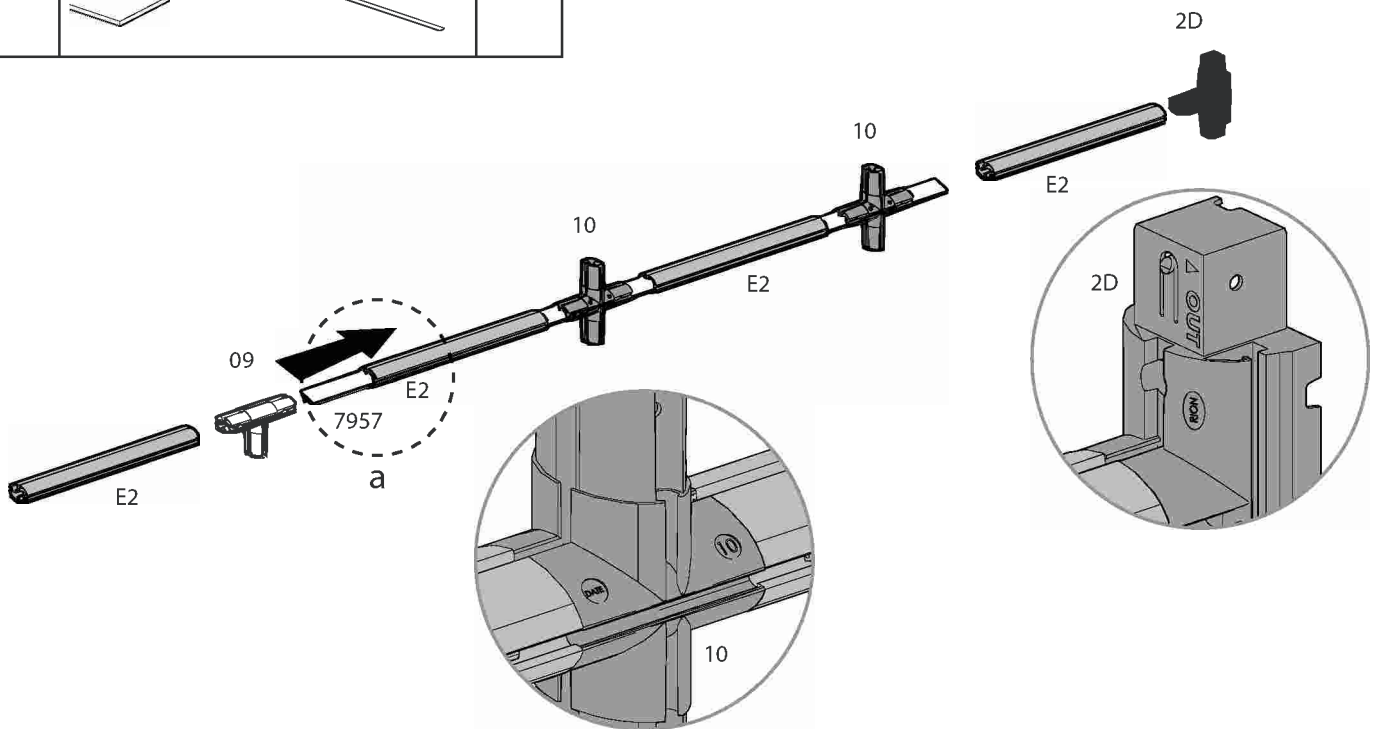
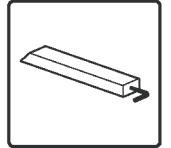

Item		Qty.
10		2
09		1
2D		1
E2		4
7957		1

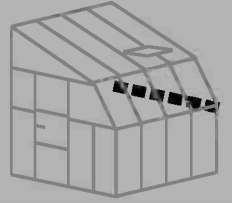

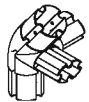

Item		Qty.
53		1
pin1		16

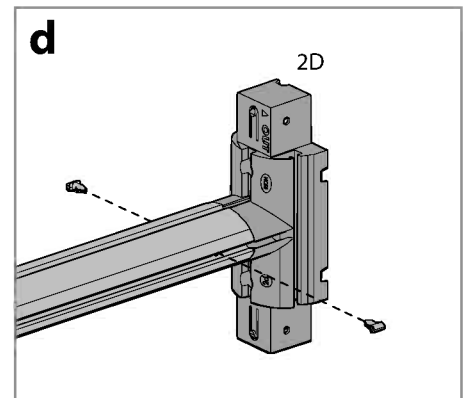
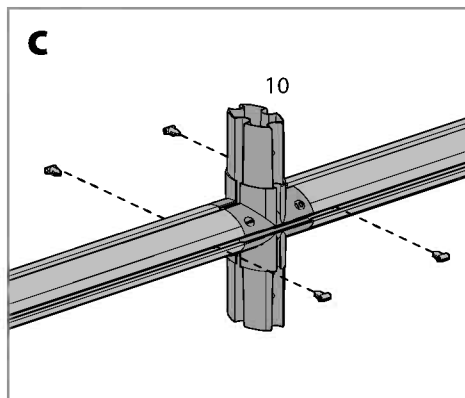
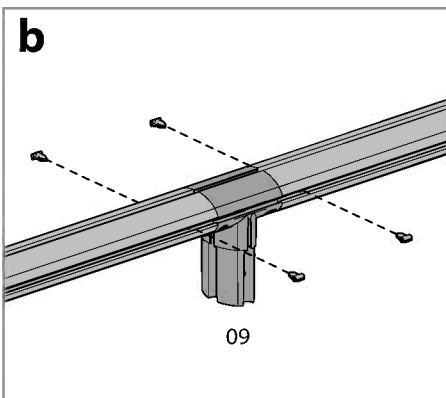
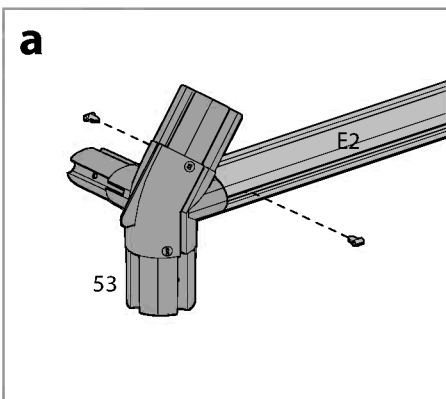
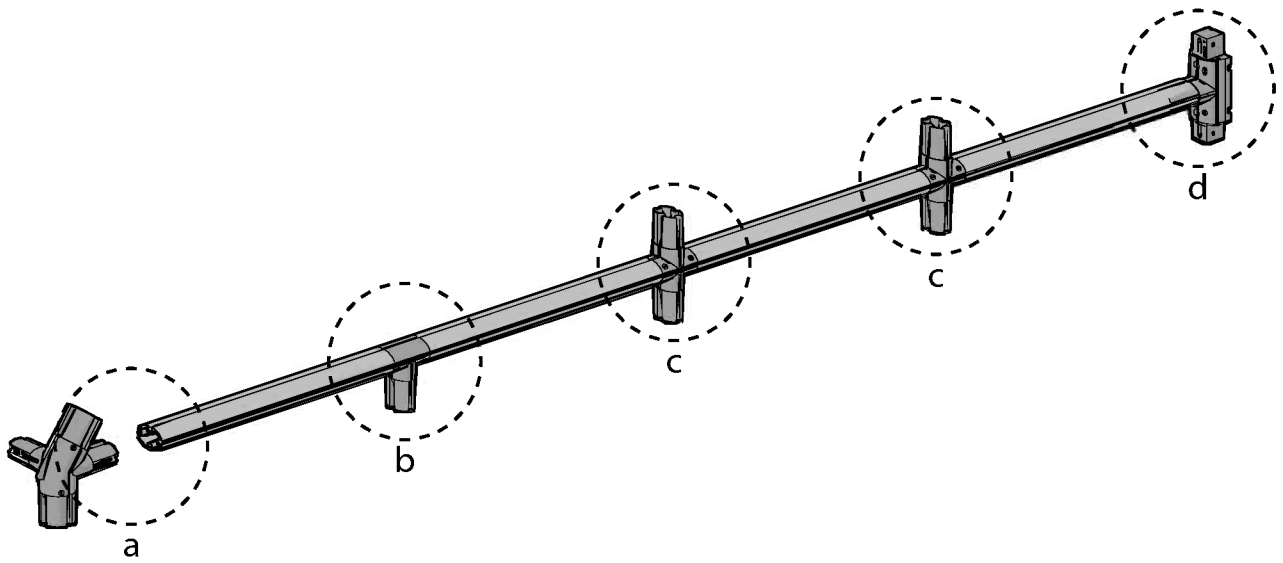
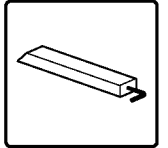

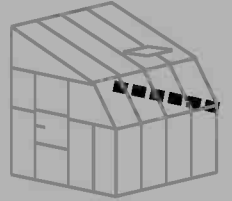

Item		Qty.
pin1		10

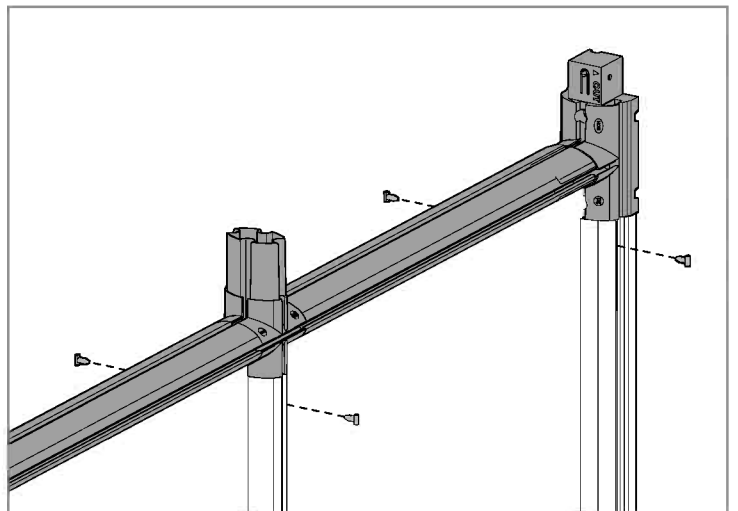
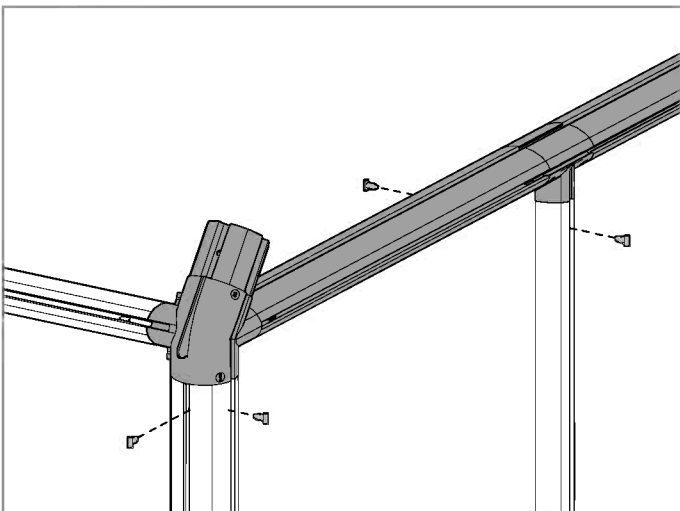
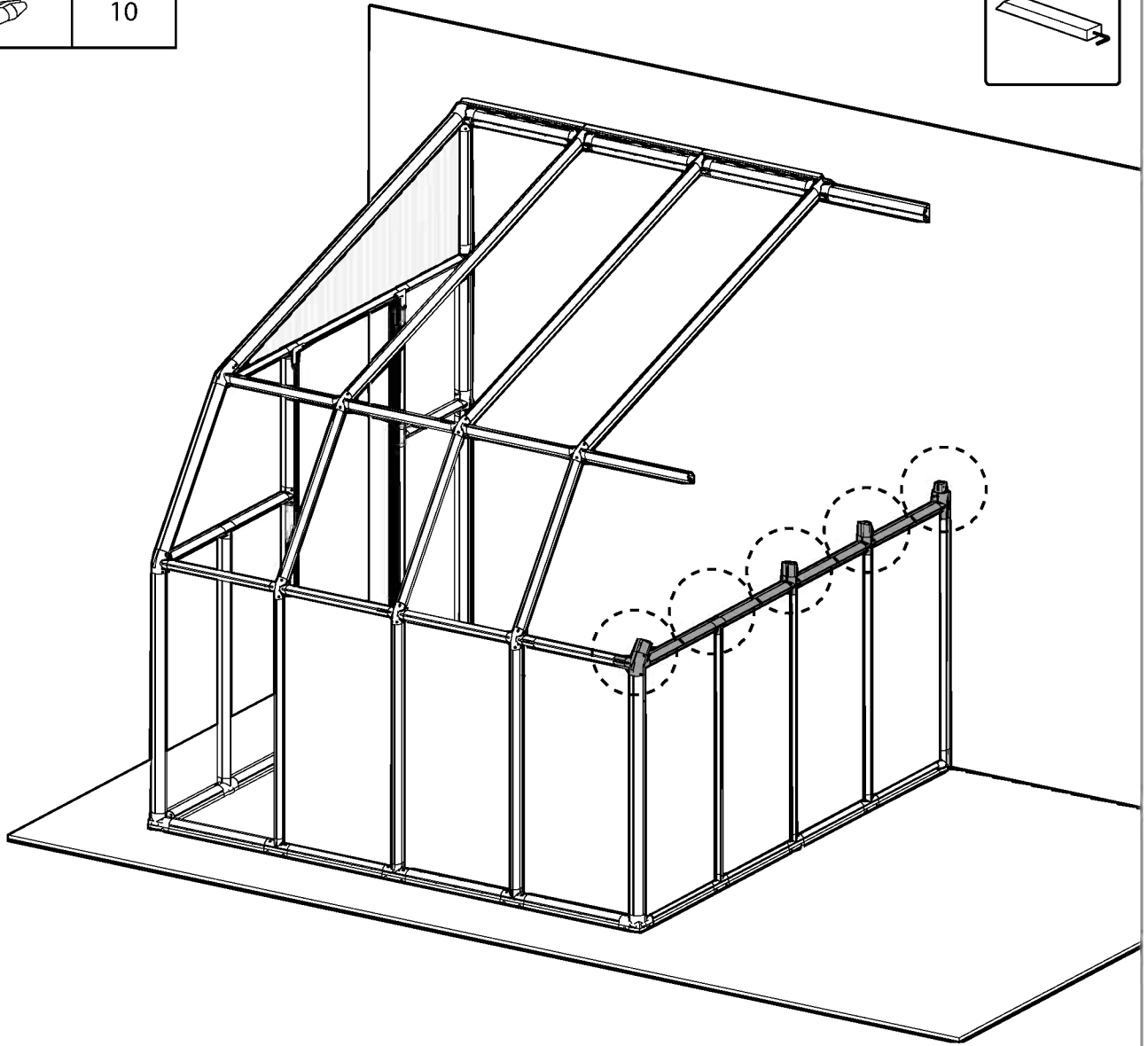
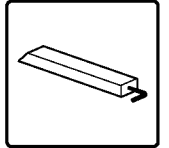

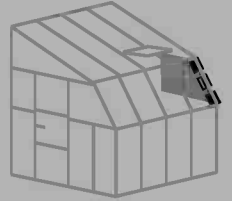

Item		Qty.
PN51		1
R10		1
7608		1
pin1		2

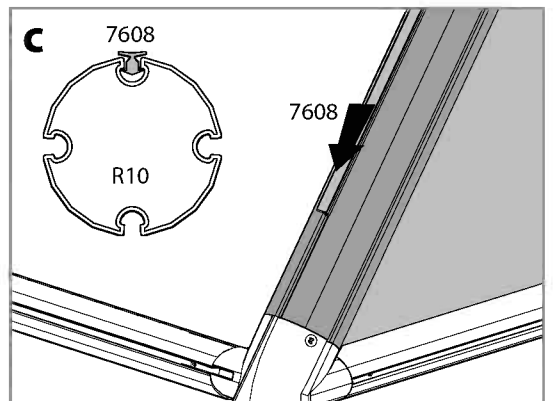
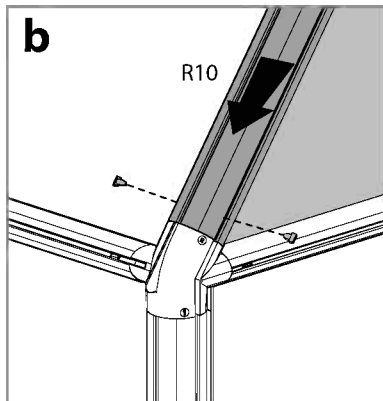
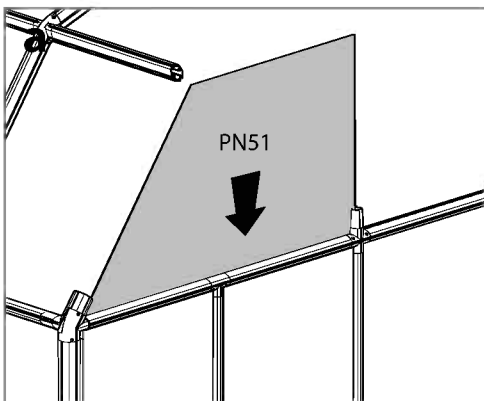
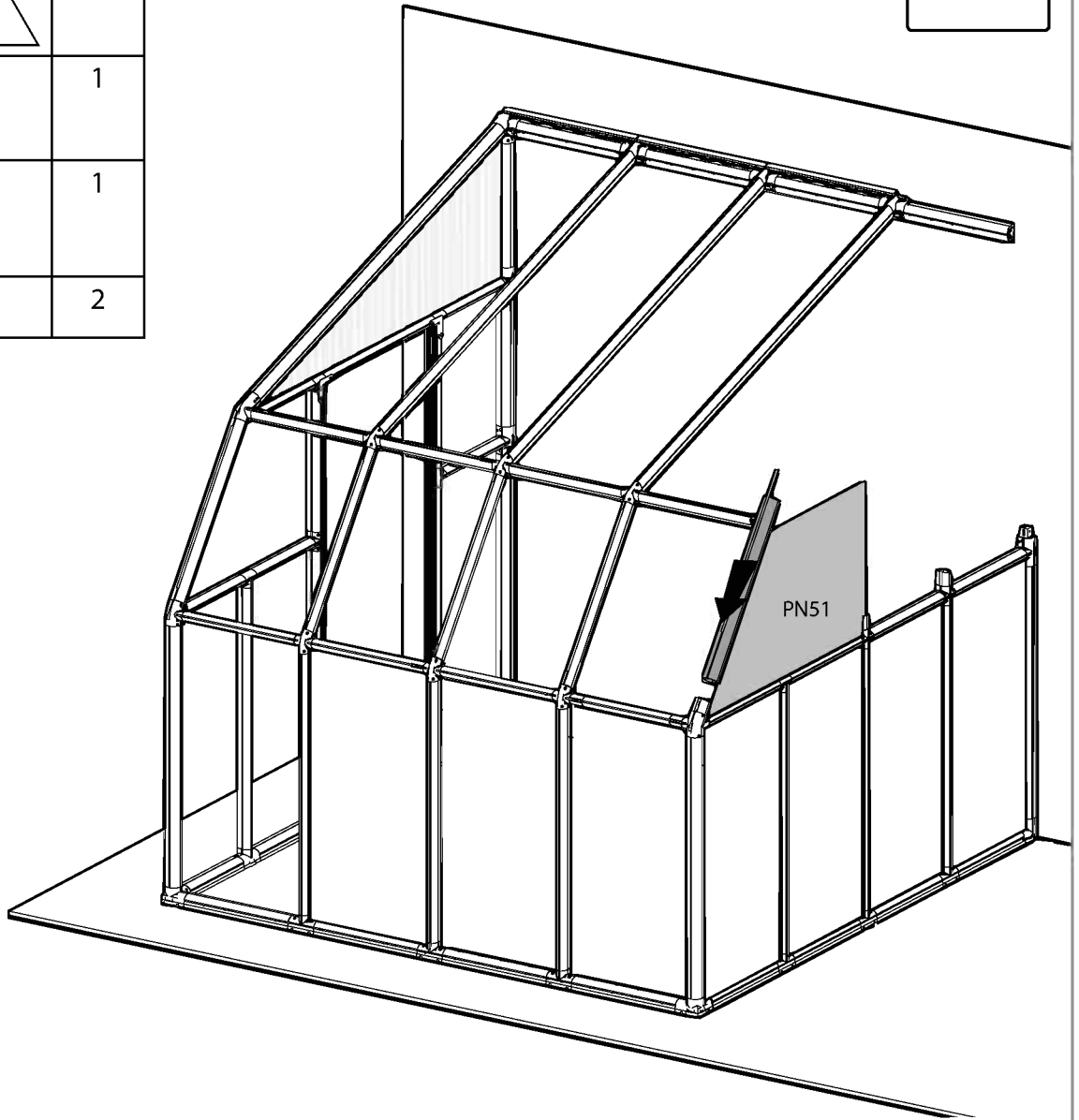
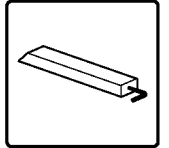

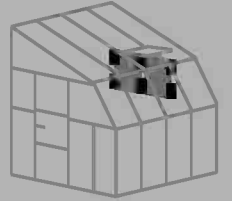

Item		Qty.
P53		2
E13		2
B12		1
pin1		6

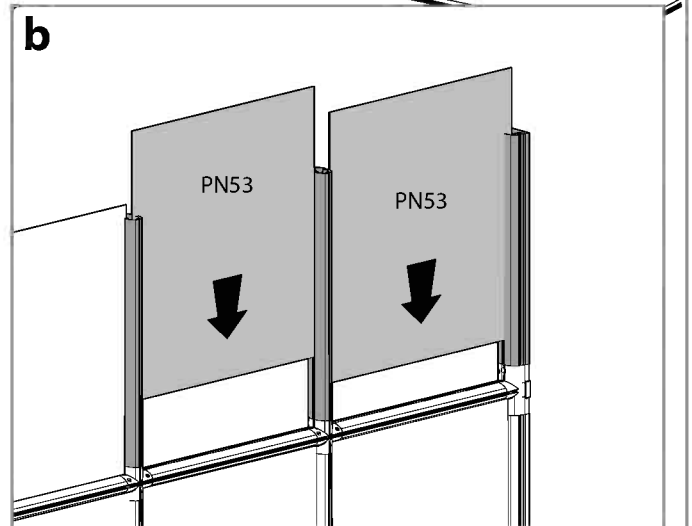
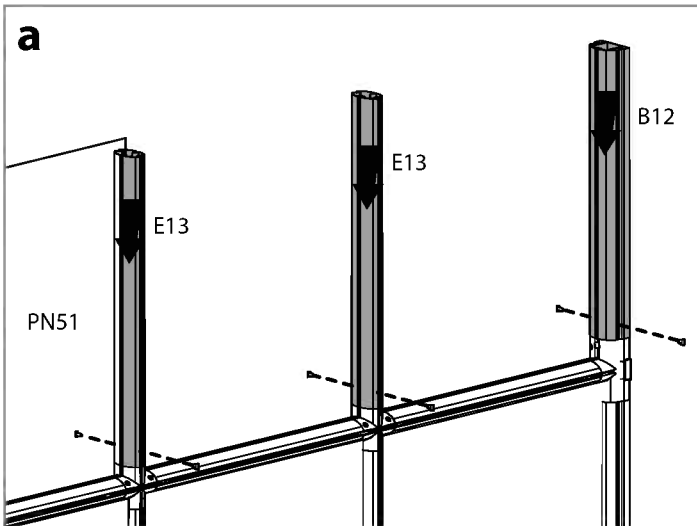
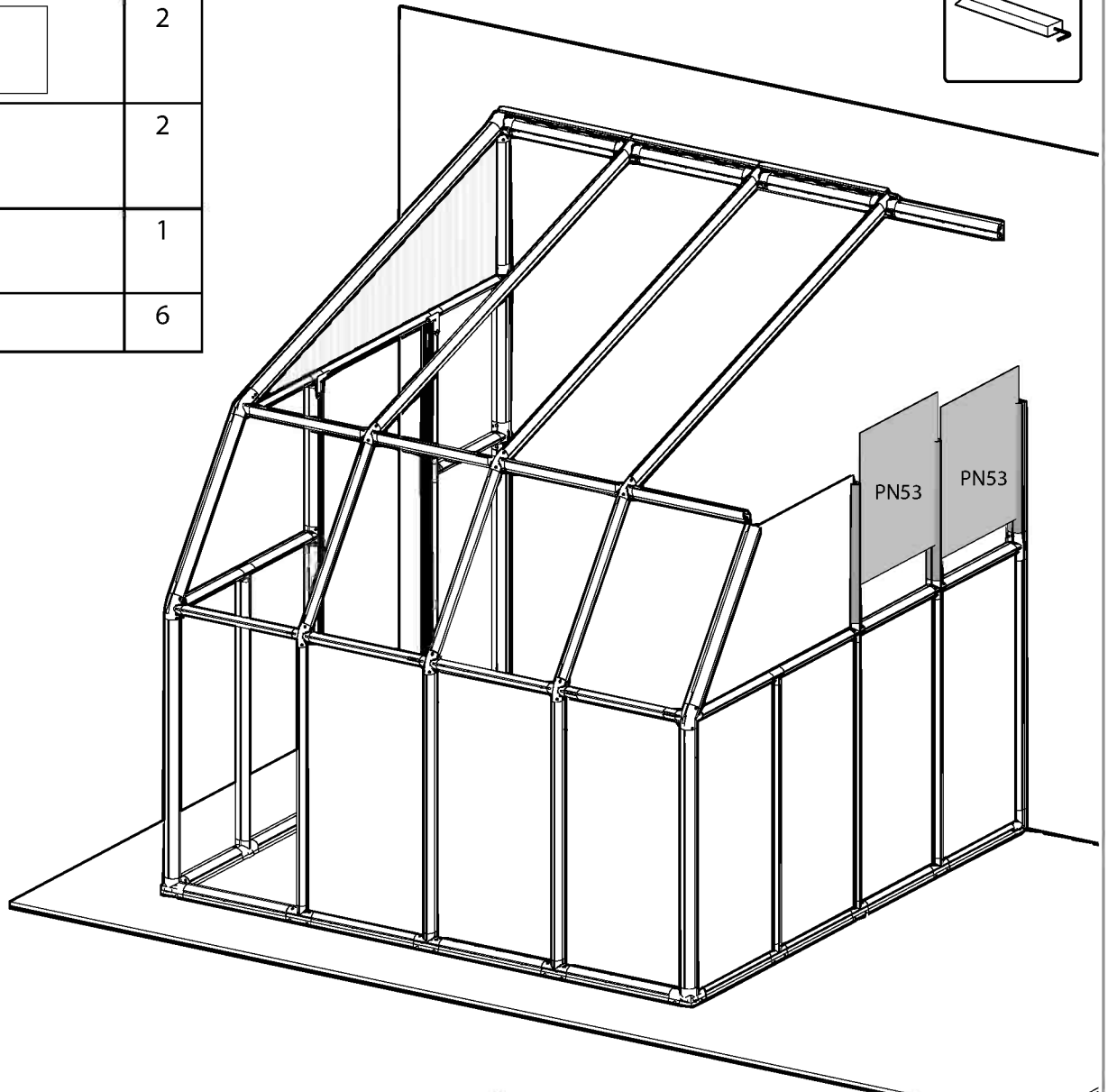
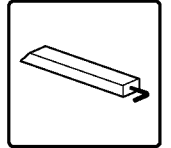

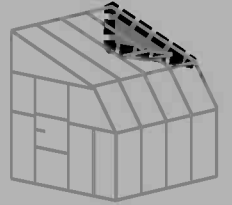

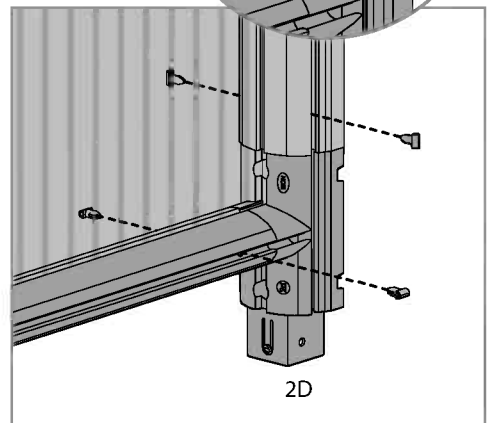
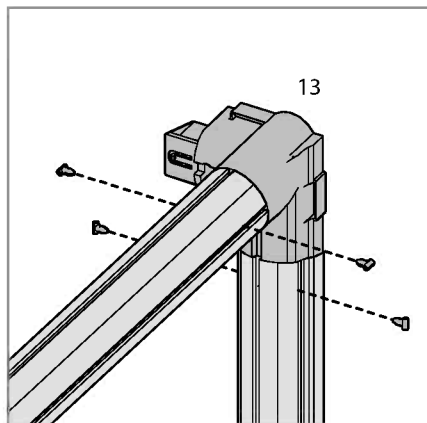
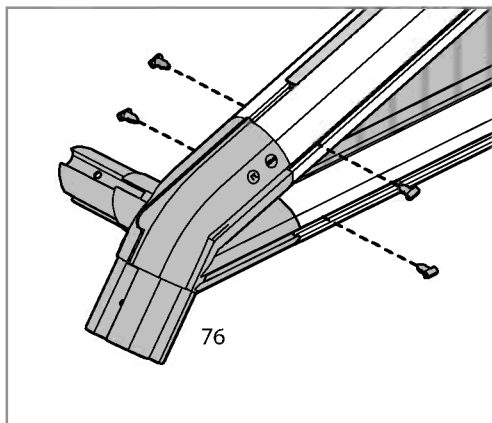
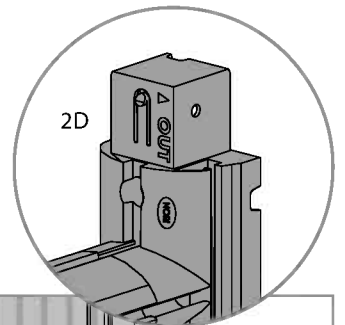
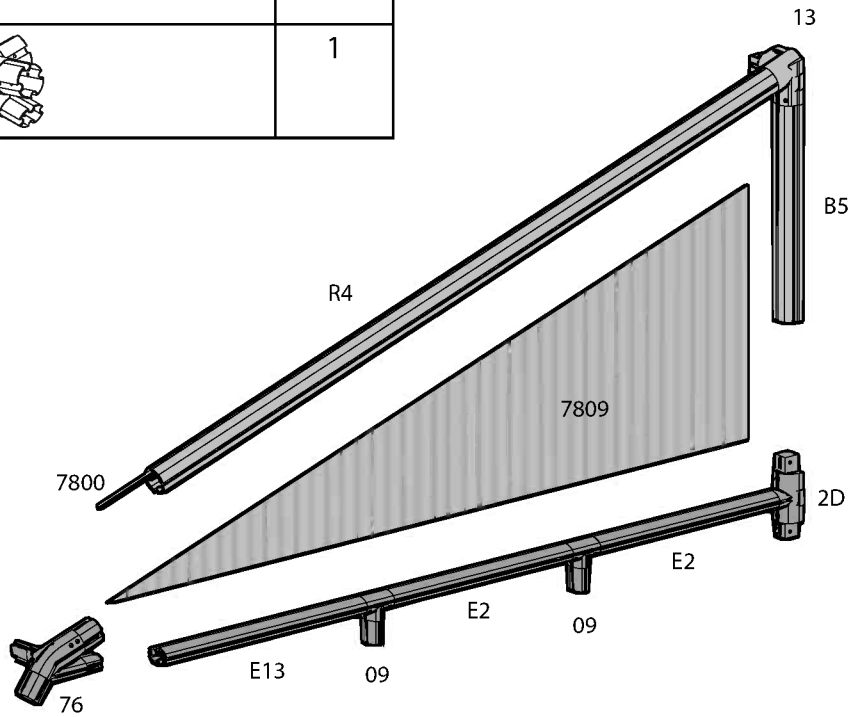
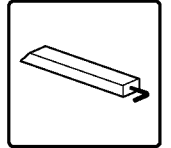

Item		Qty.
R4		1
E2		2
E13		1
7800		1
B5		1
13		1
76		1

Item		Qty.
09		2
2D		1
7809		1
pin1		20

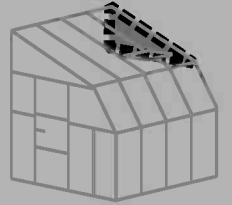



Item		Qty.
pin1		14

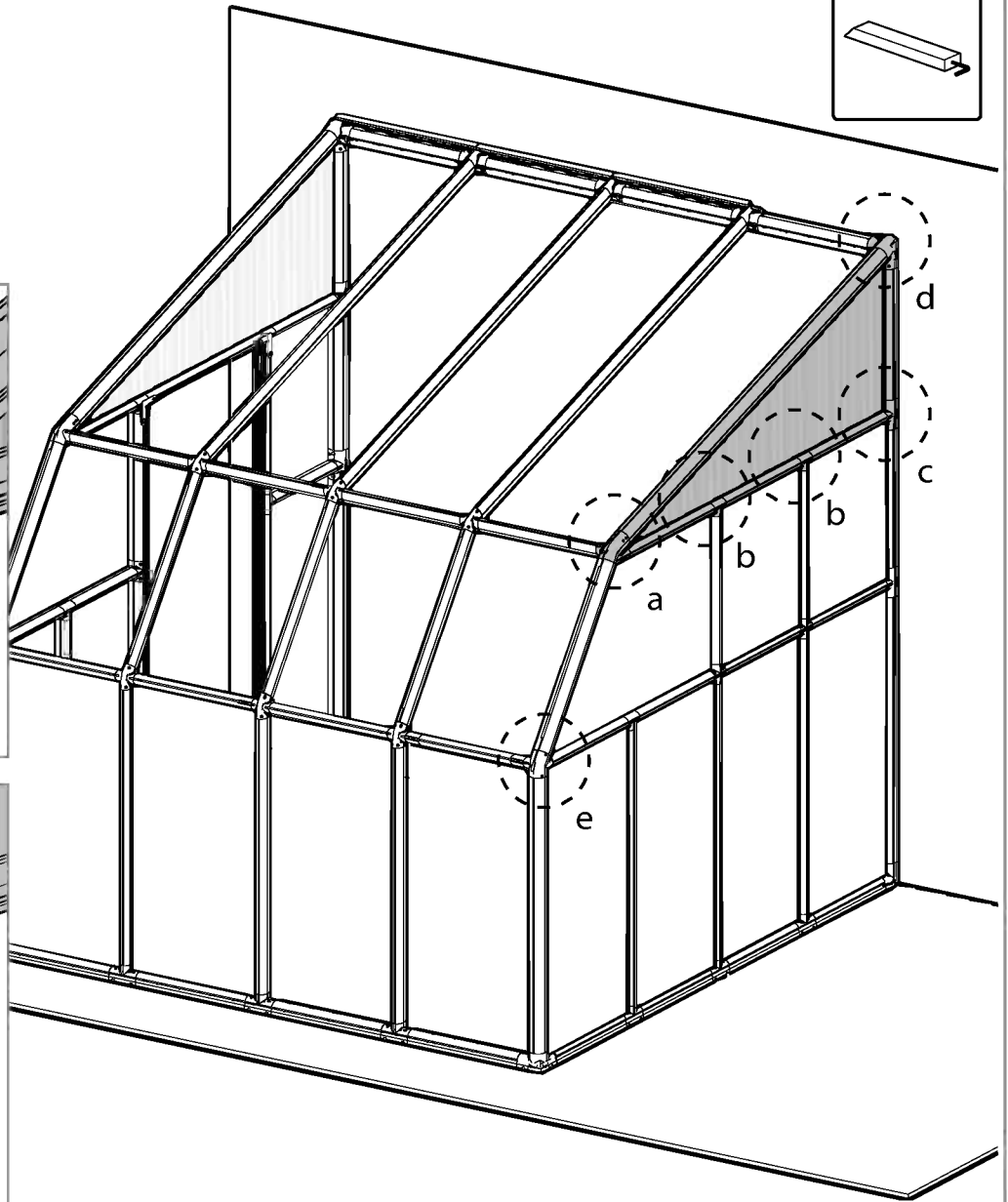
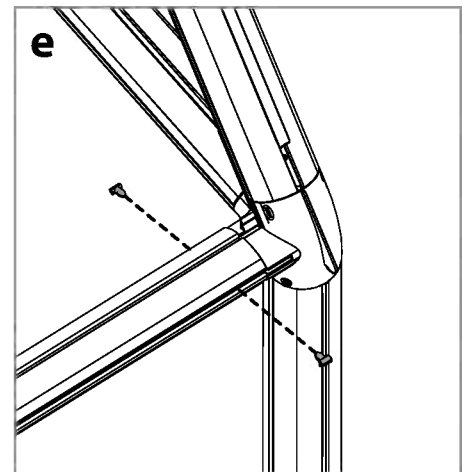
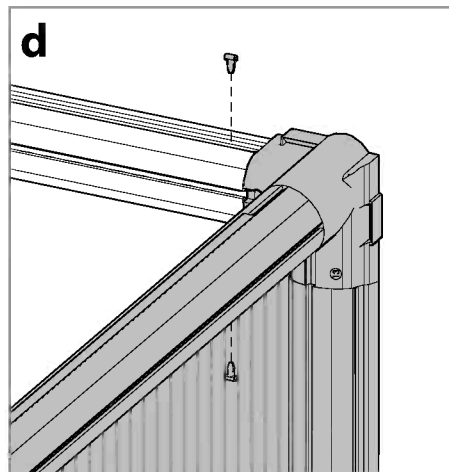
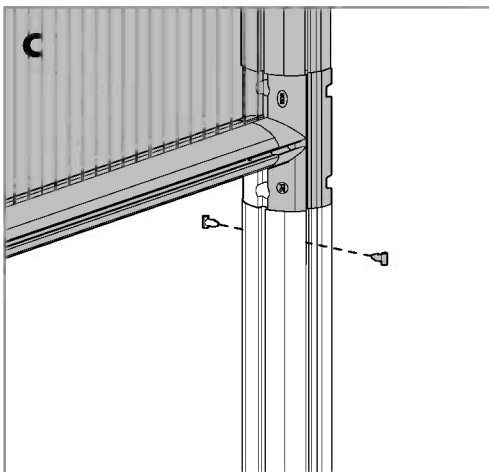
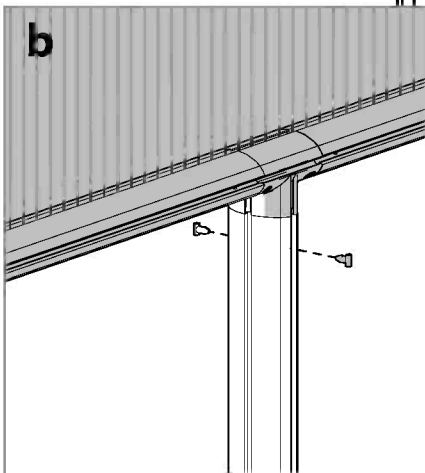
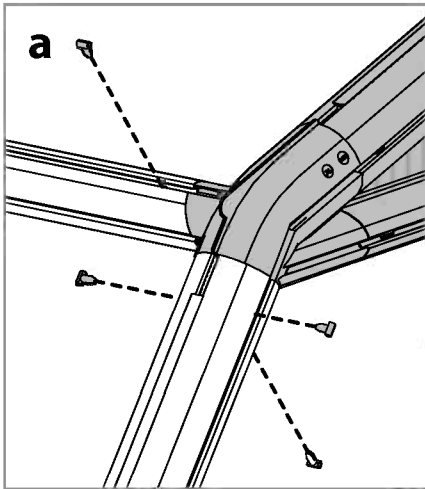
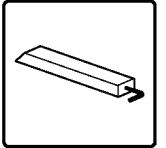

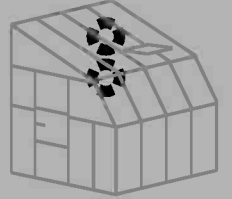

Item		Qty.
BC1		2

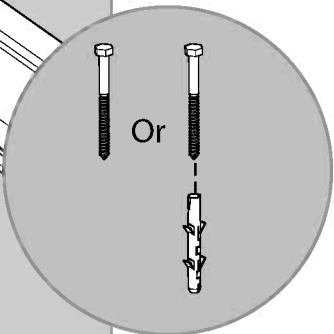
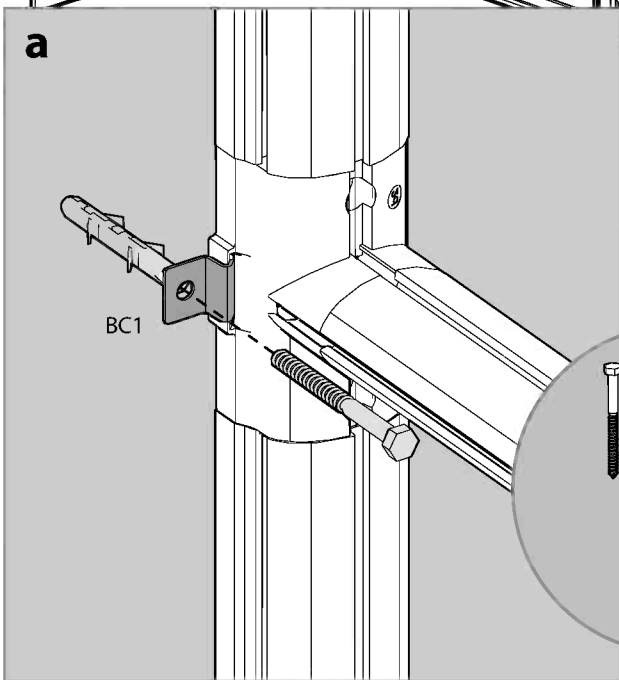
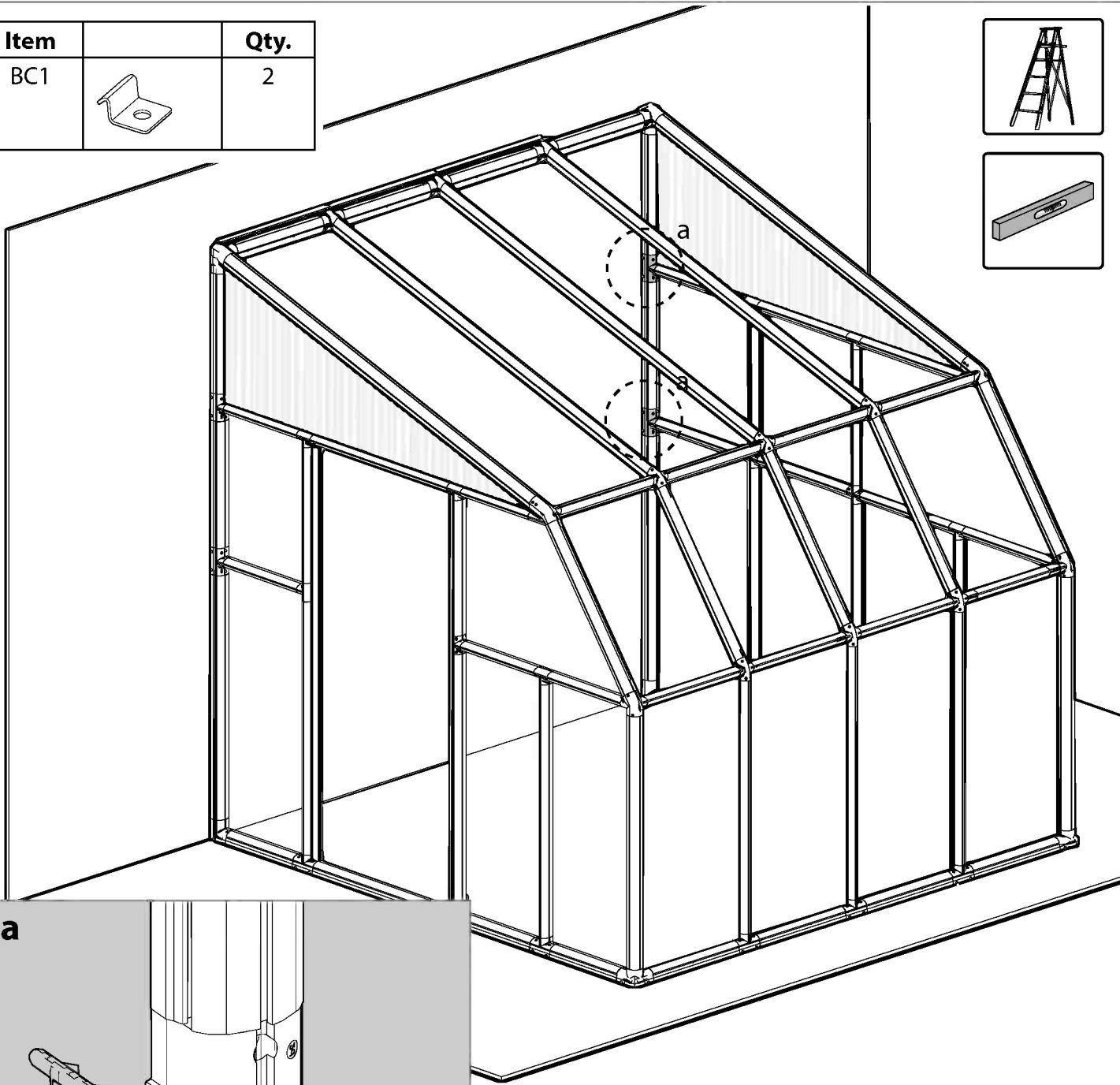
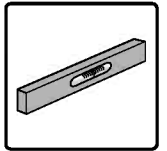

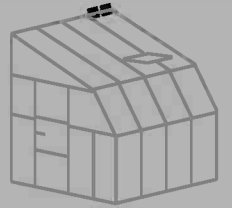

Item		Qty.
7937		1

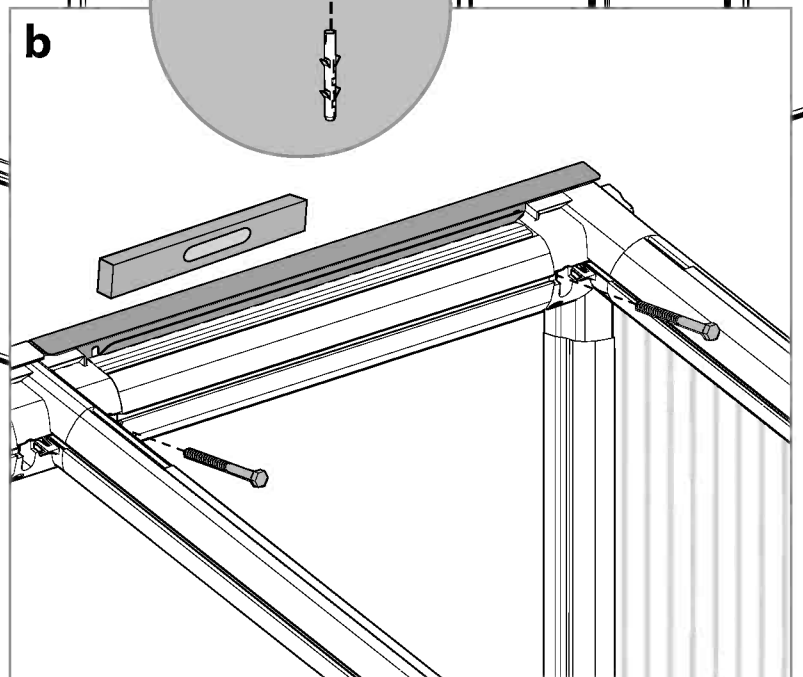
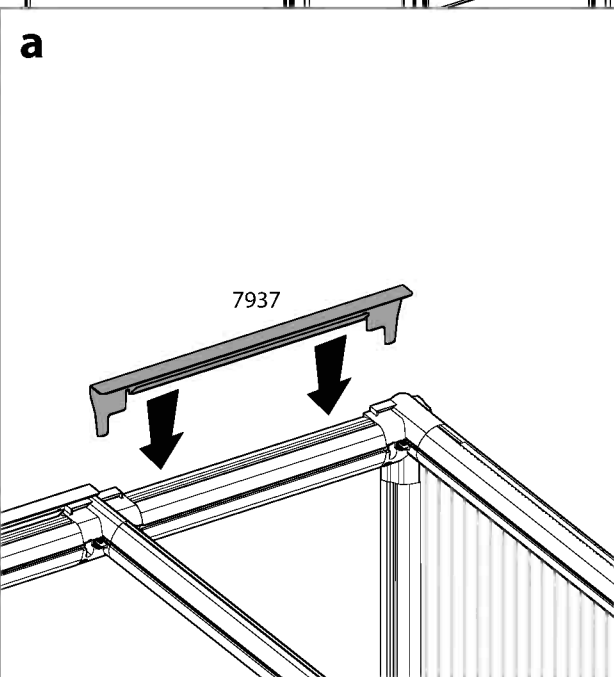
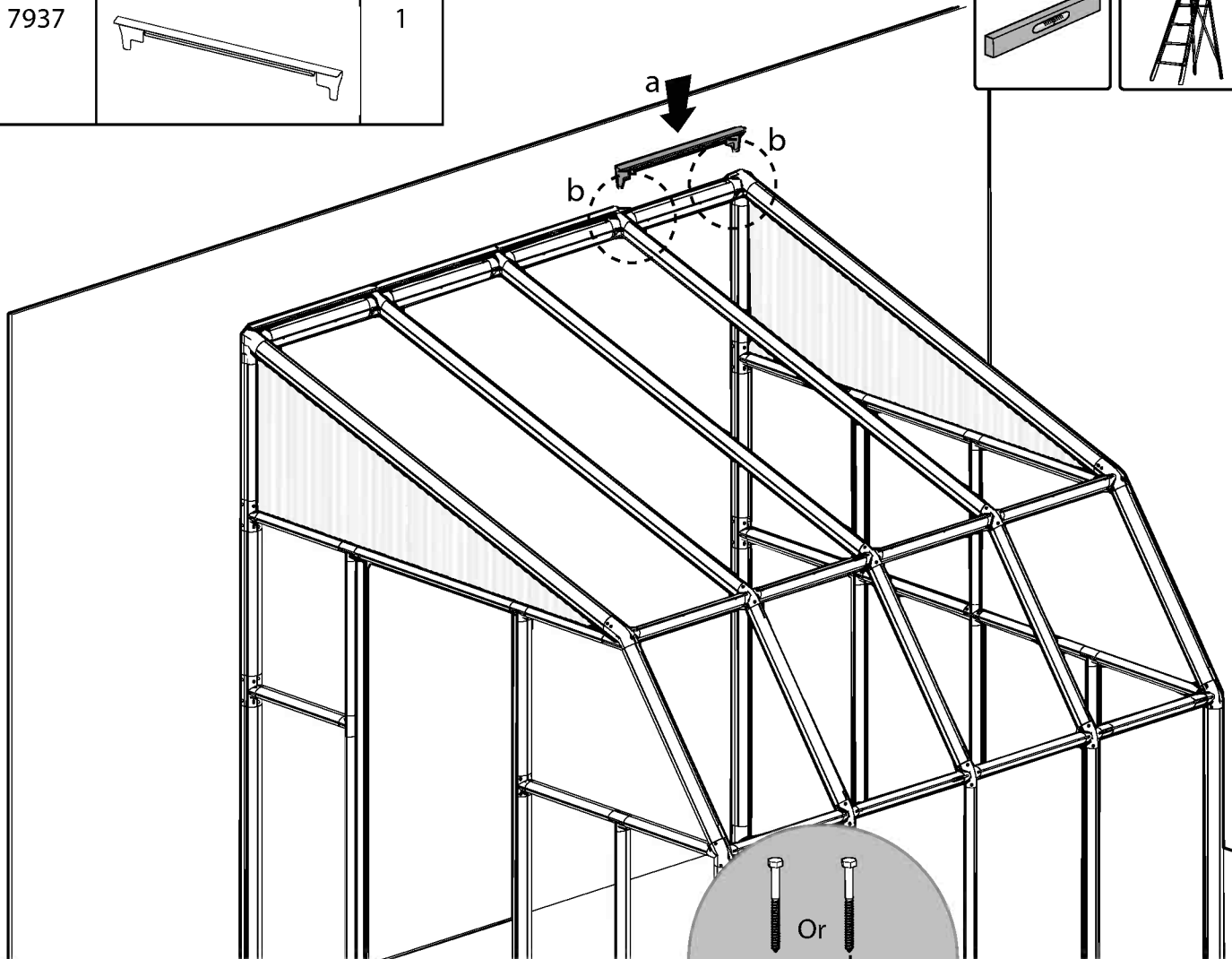
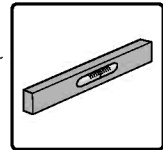

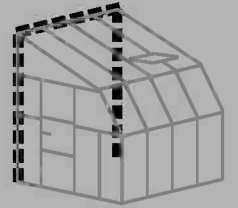

CAULK / SILICON

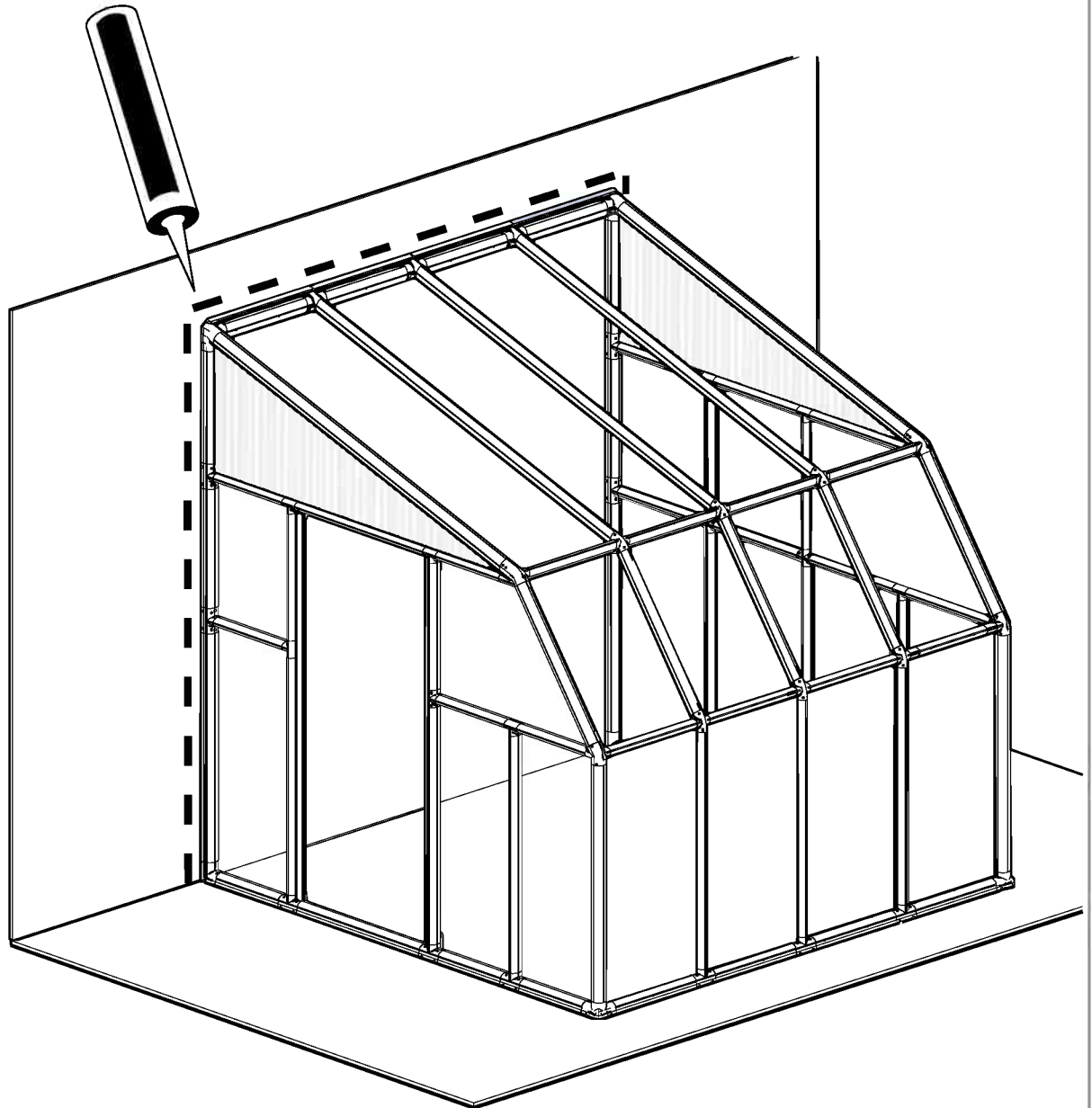

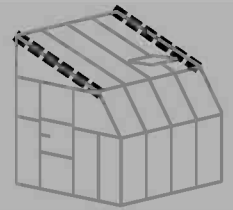

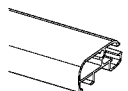
Item		Qty.
7805		2

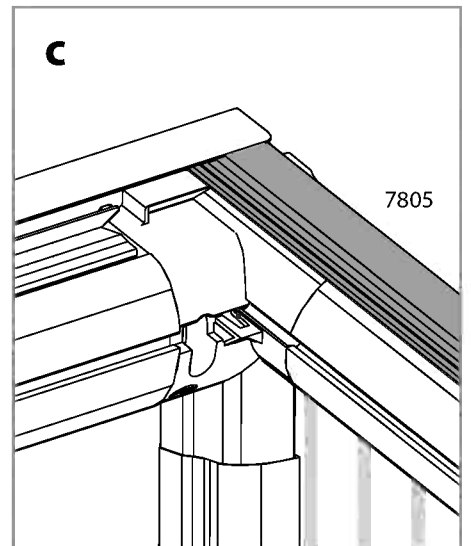
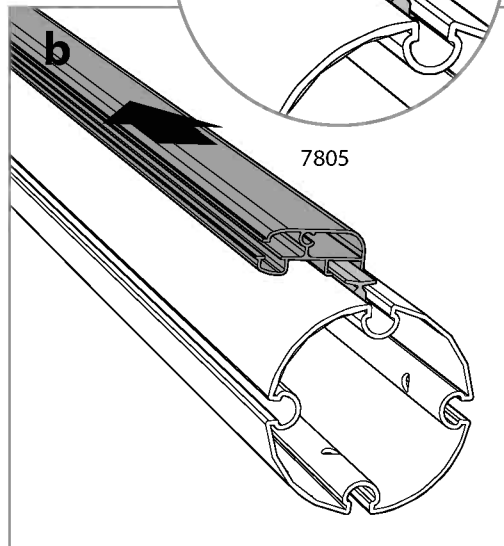
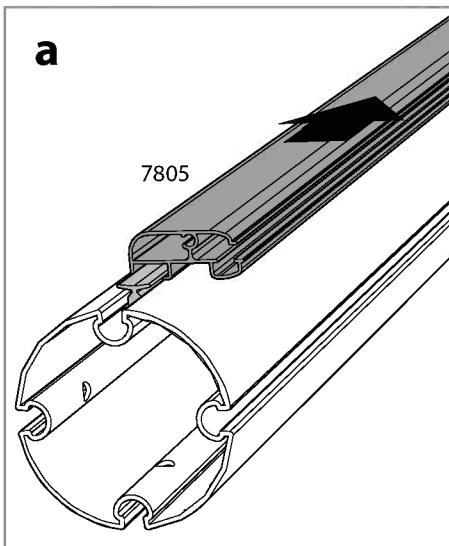
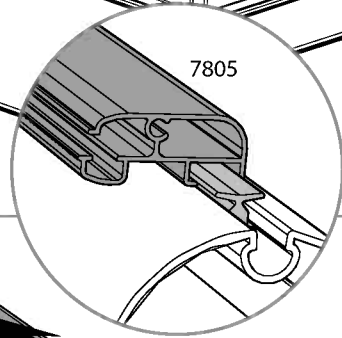
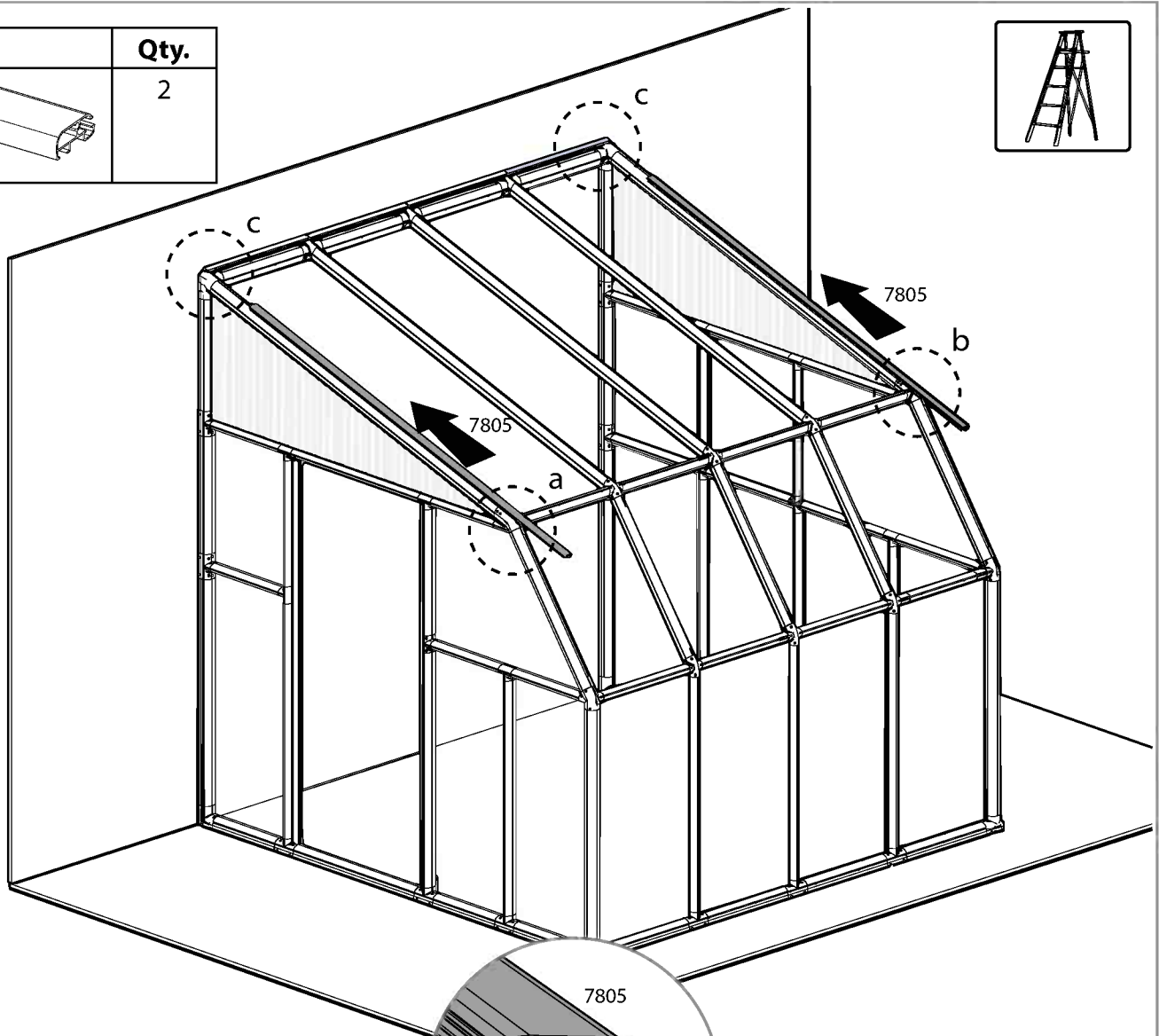

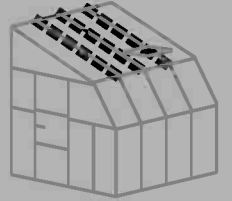

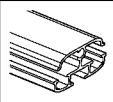
Item		Qty.
7804		3

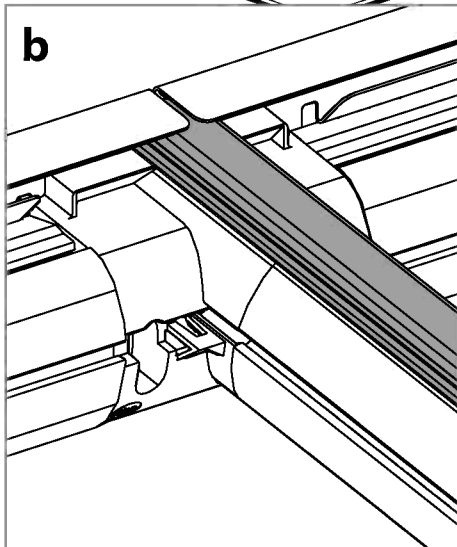
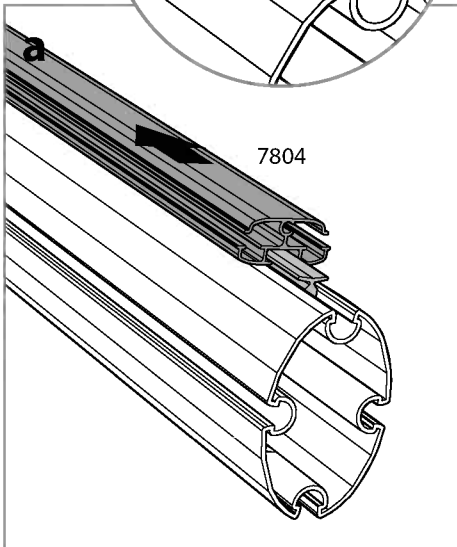
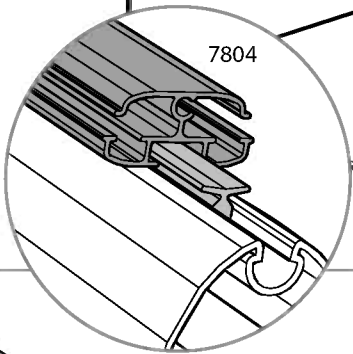
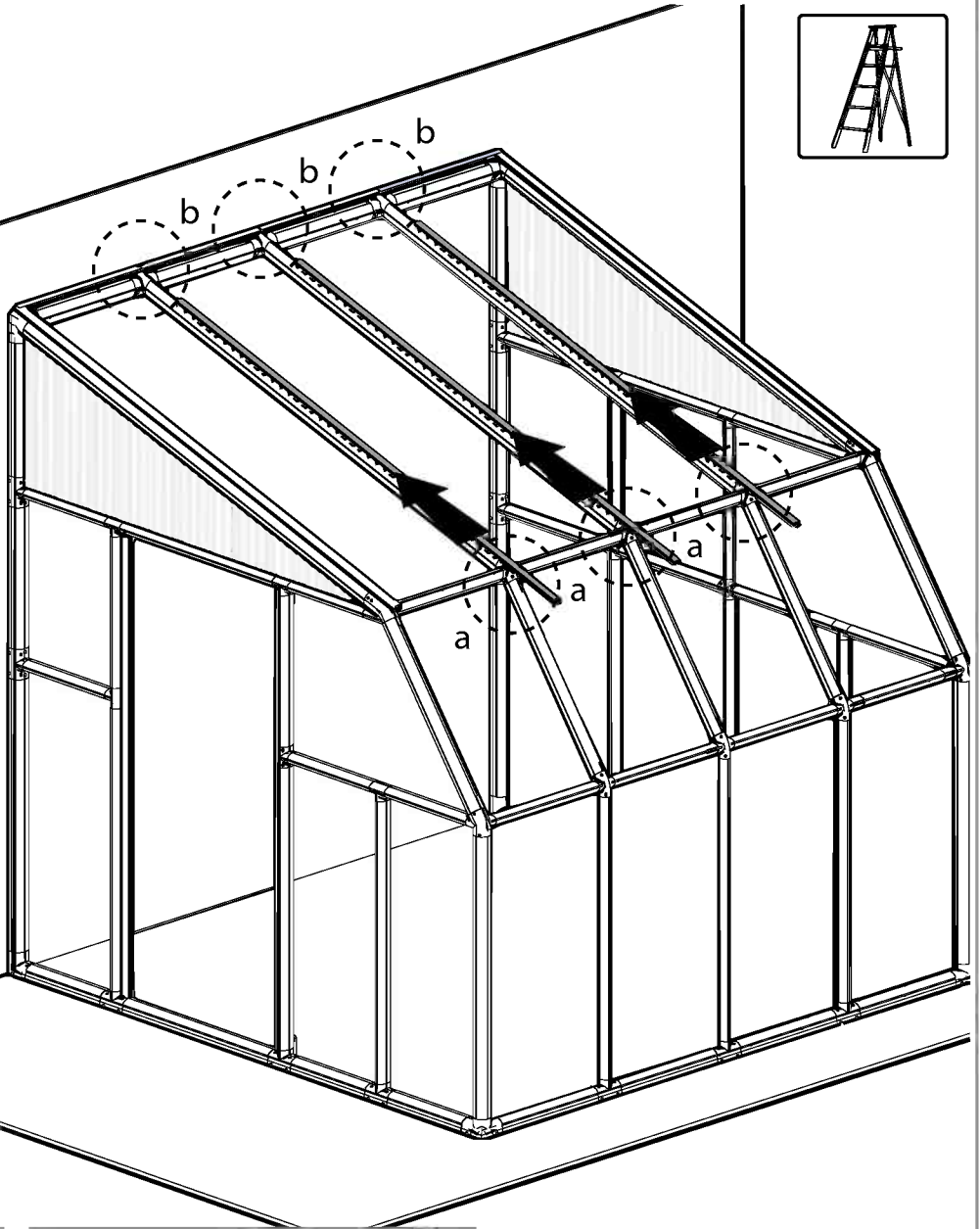
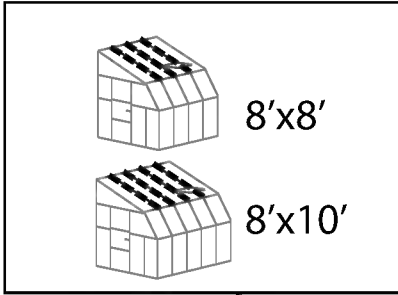

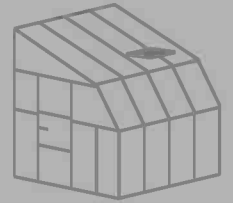

Item		Qty.
992		2
586		1

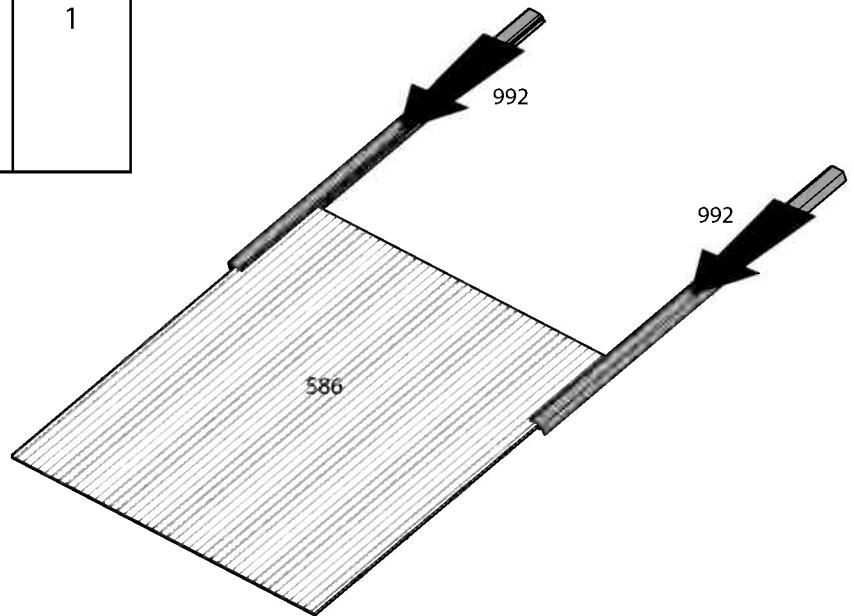
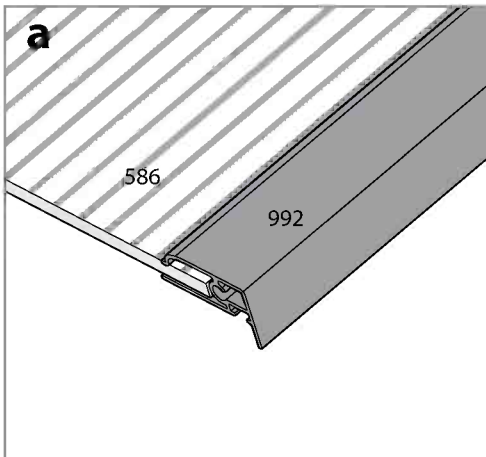

Item		Qty.
SF		1

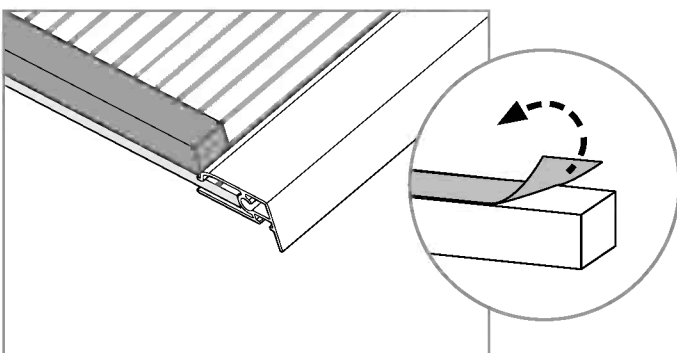
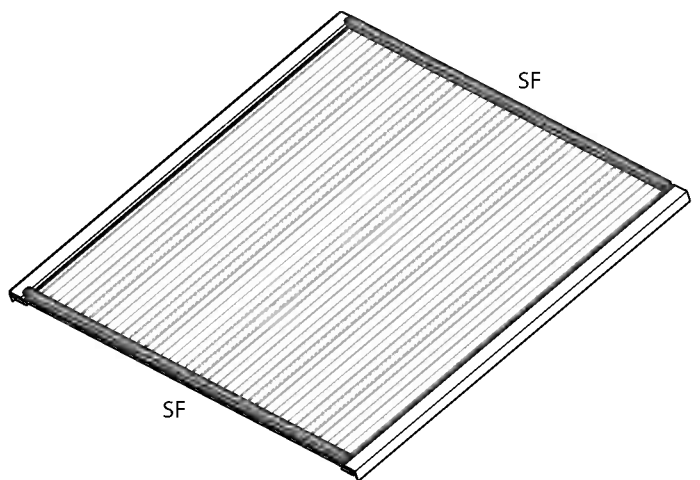
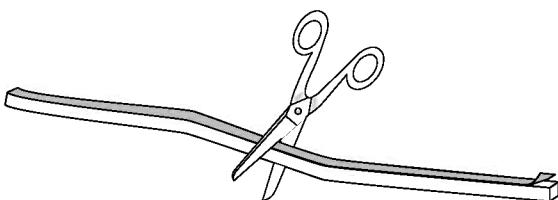



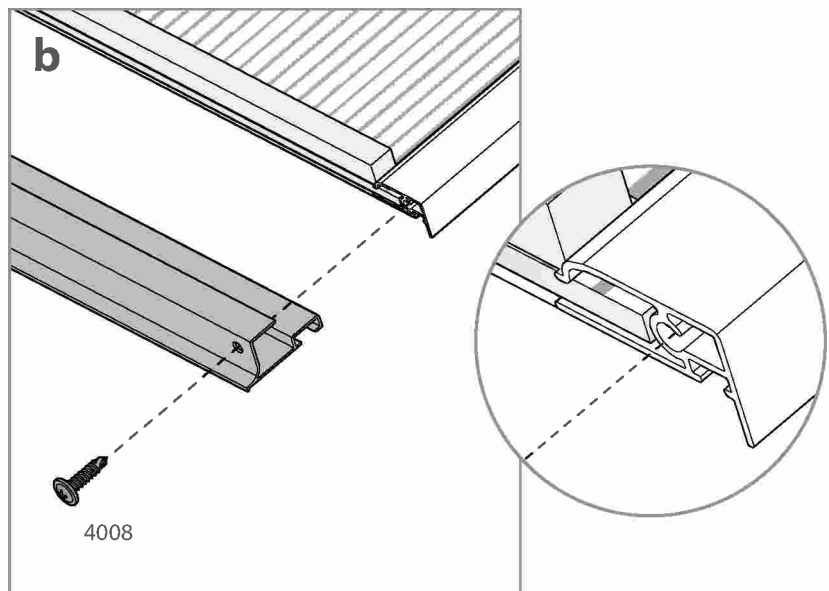
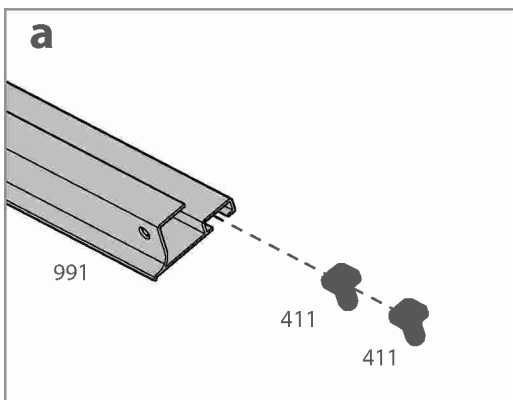
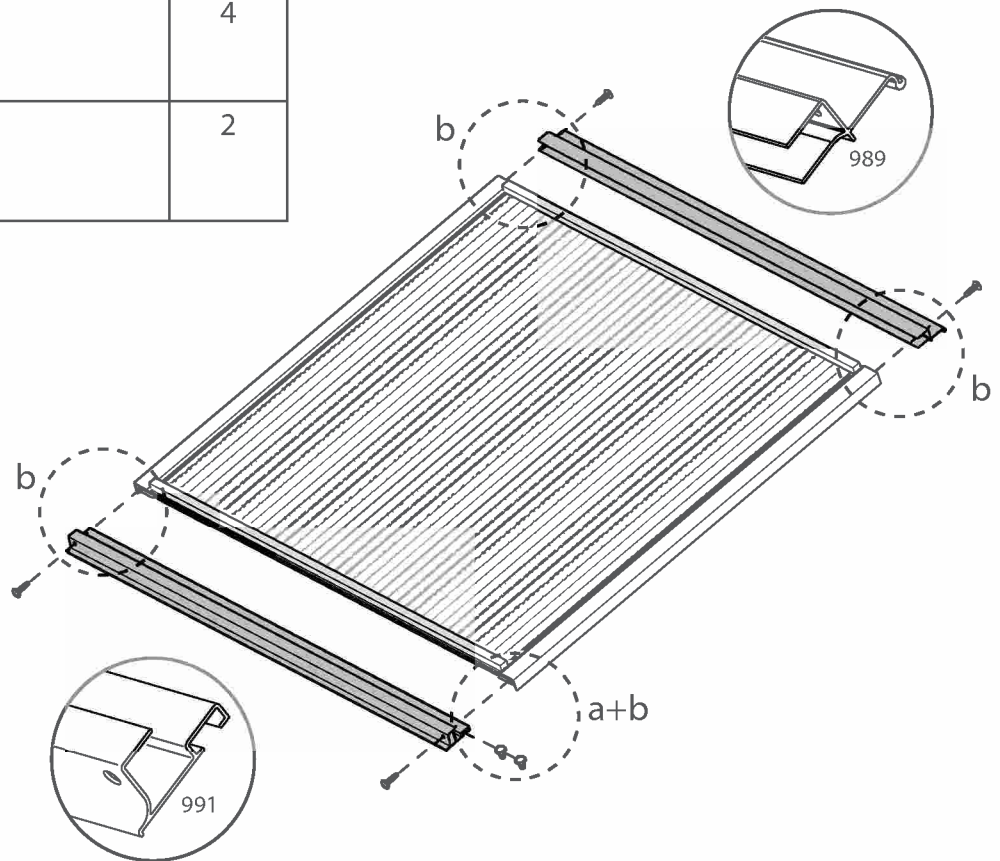

Item		Qty.
989		1
991		1
4008		4
411		2



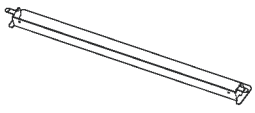
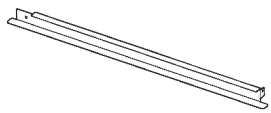
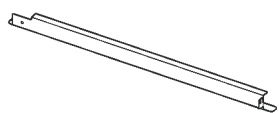

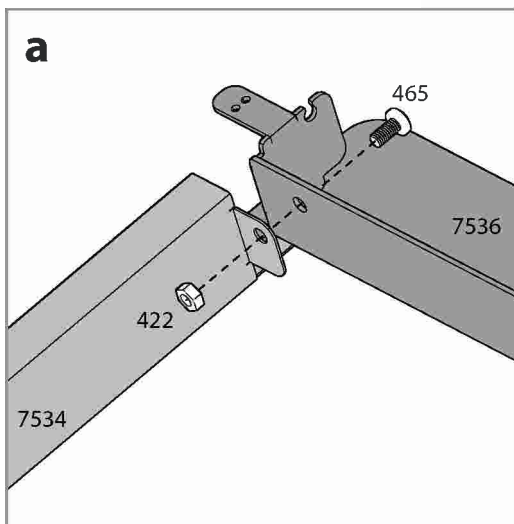
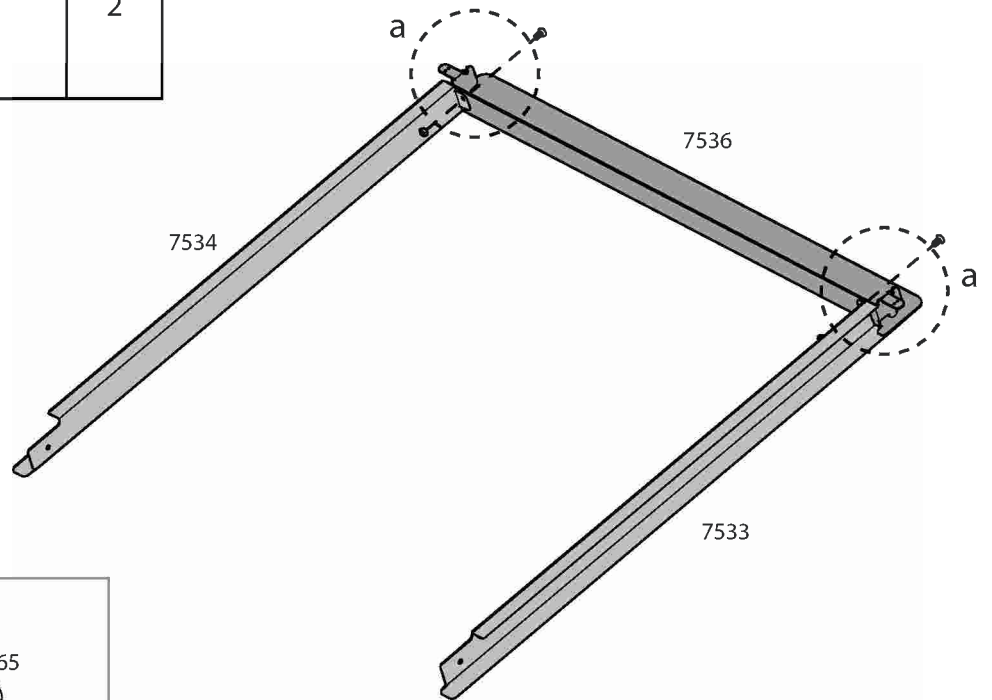
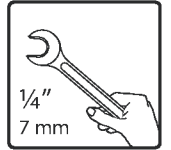
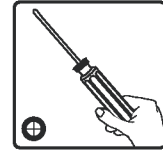

Item		Qty.
7536		1
7533		1
7534		1
465	 M4x8mm	2
422	 M4	2

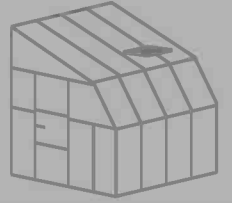

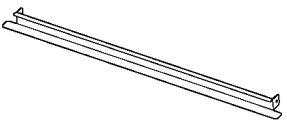

Item		Qty.
7535		1
465	 M4x8mm	2
422	 M4	2

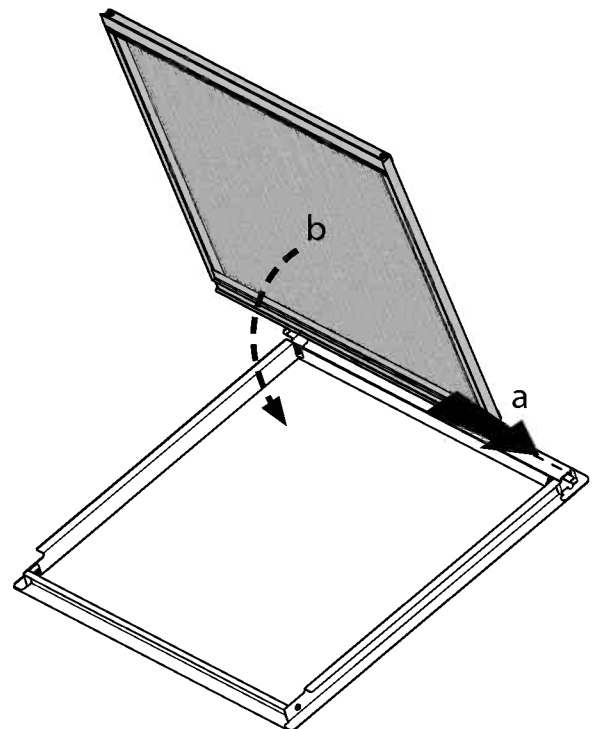
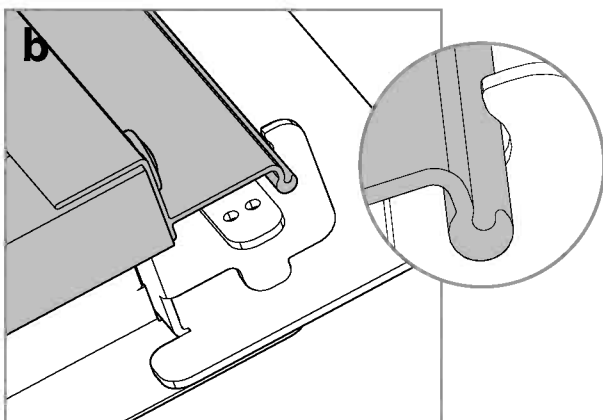
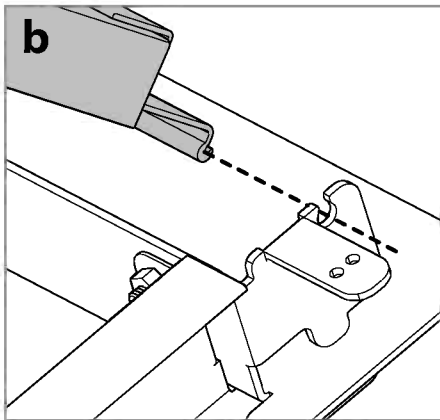
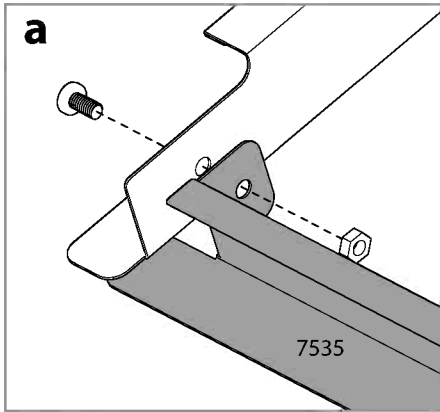
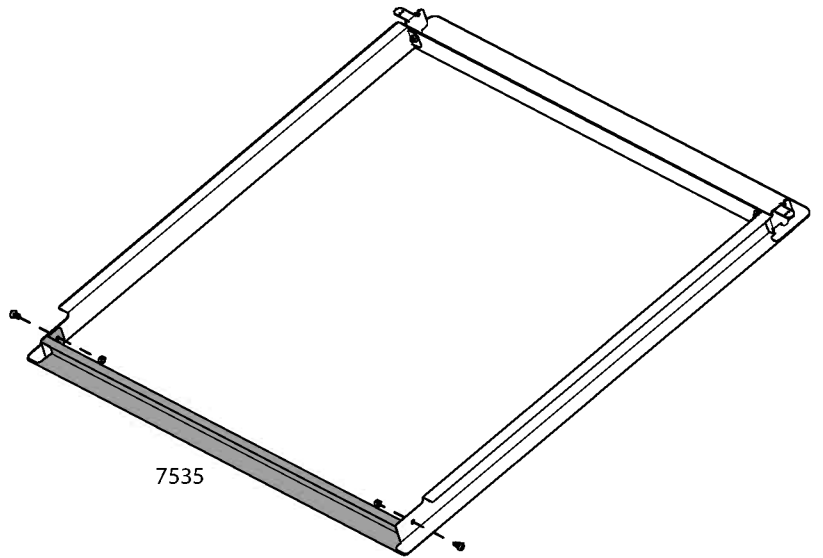
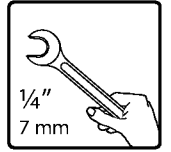
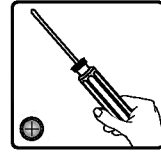

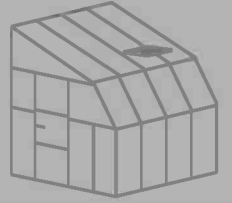

Item		Qty.
7802		1

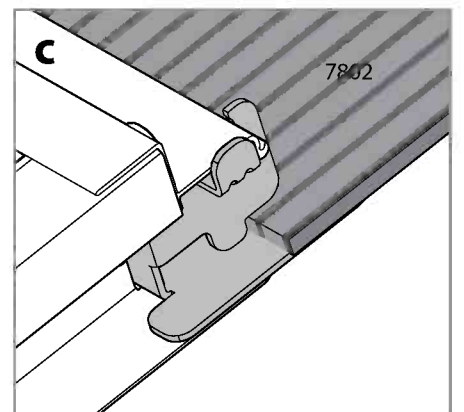
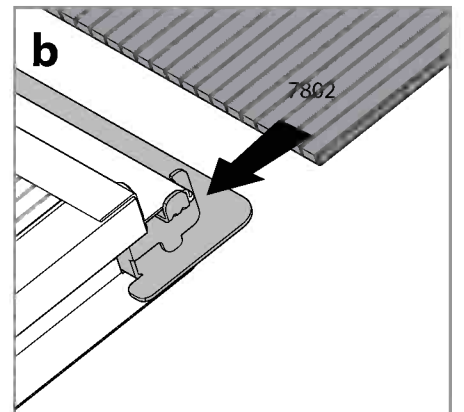
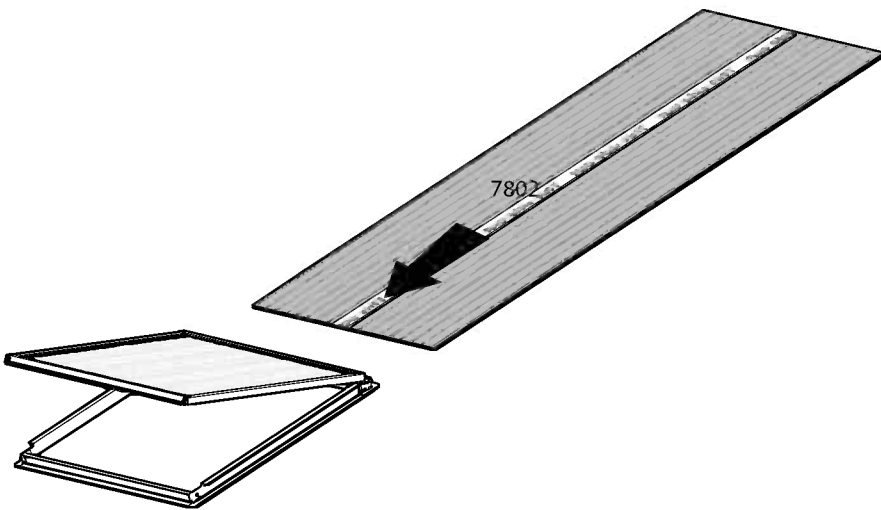
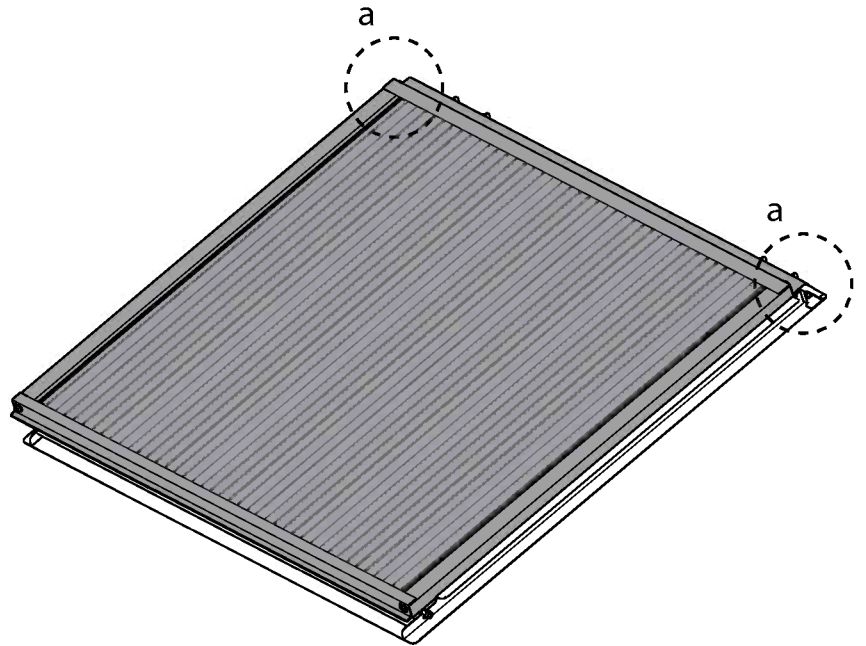
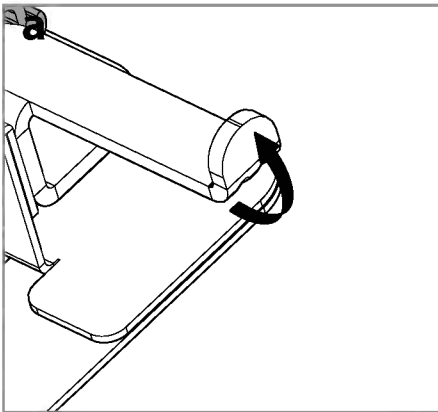
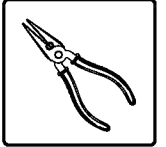



- EN** Windows Location
- DE** Fenster Standort
- FR** Fenêtre Emplacement
- ES** Ventana Ubicación

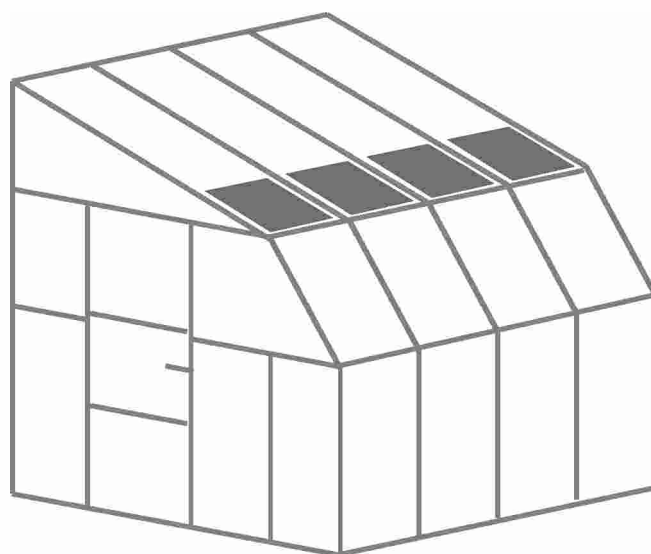
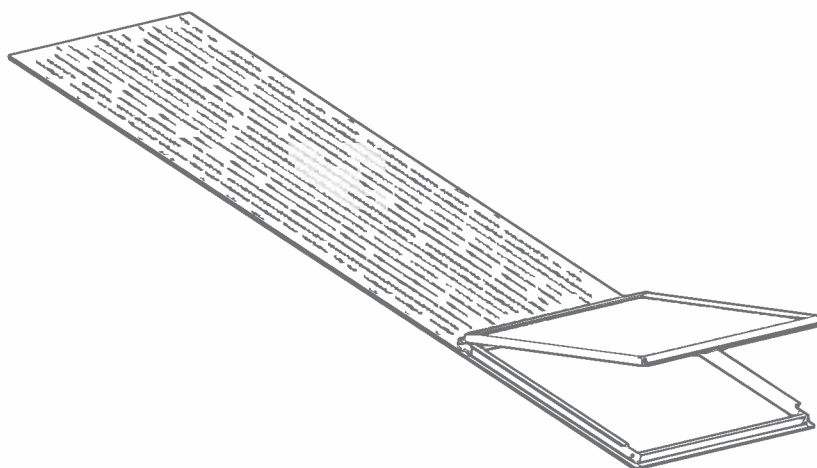

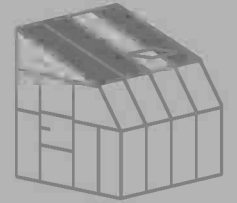

Item		Qty.
7803		3

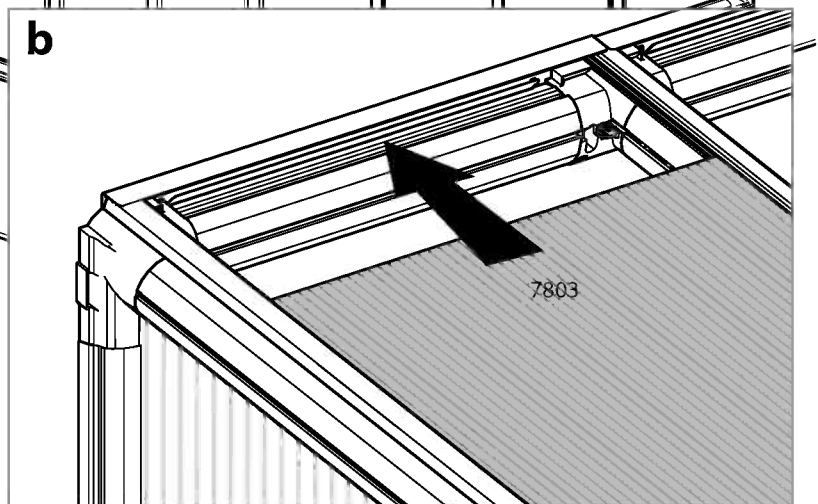
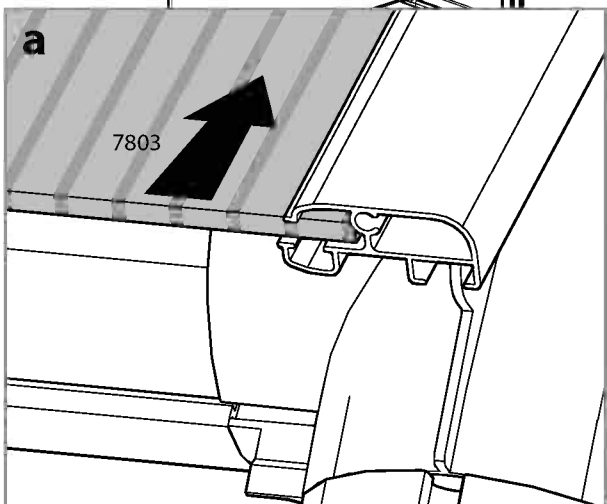
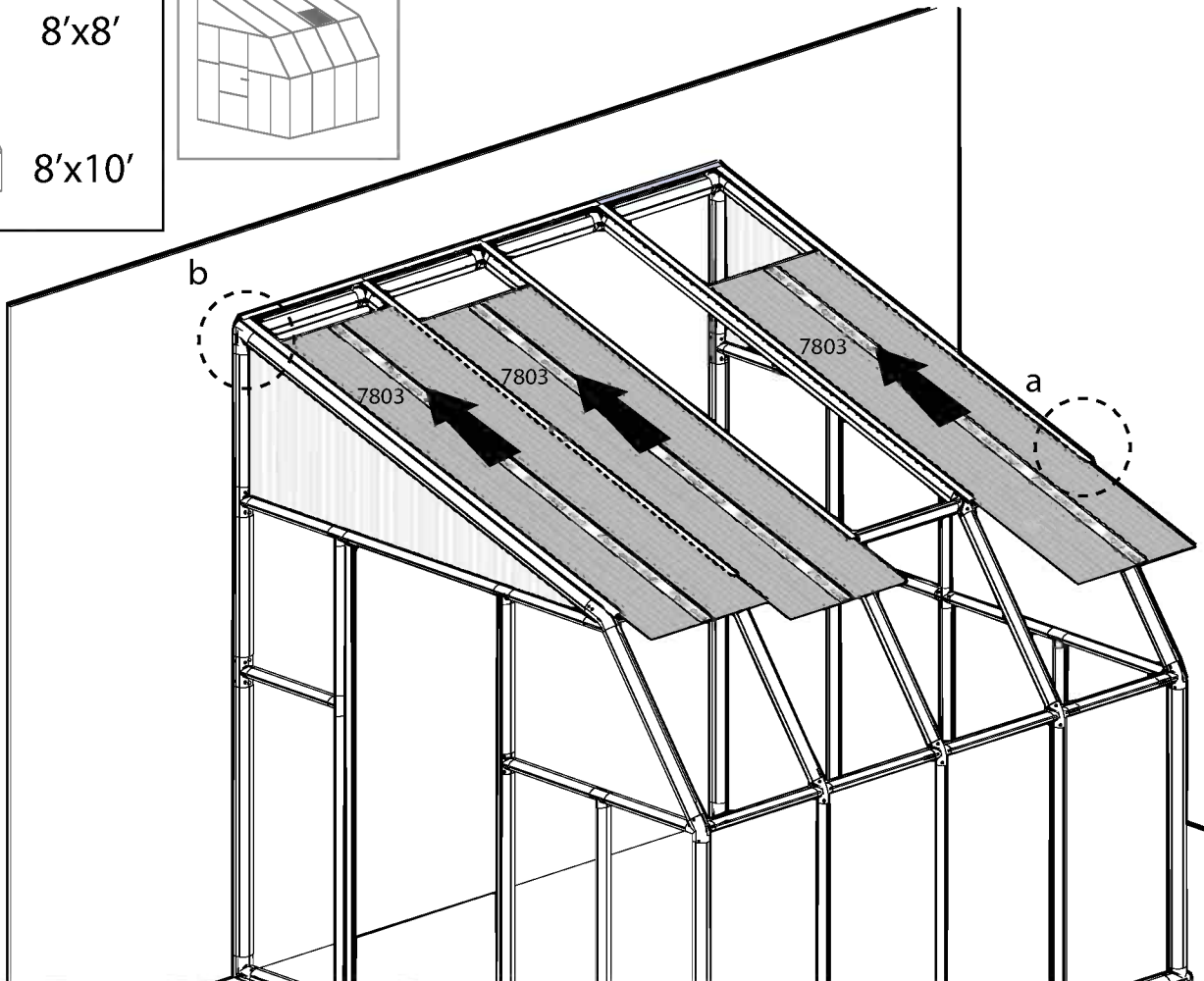
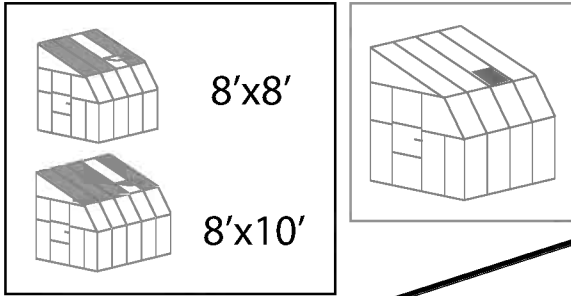

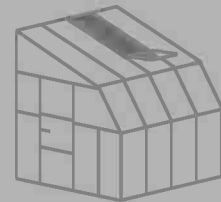

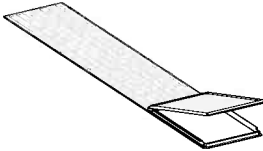
Item		Qty.
Window		1

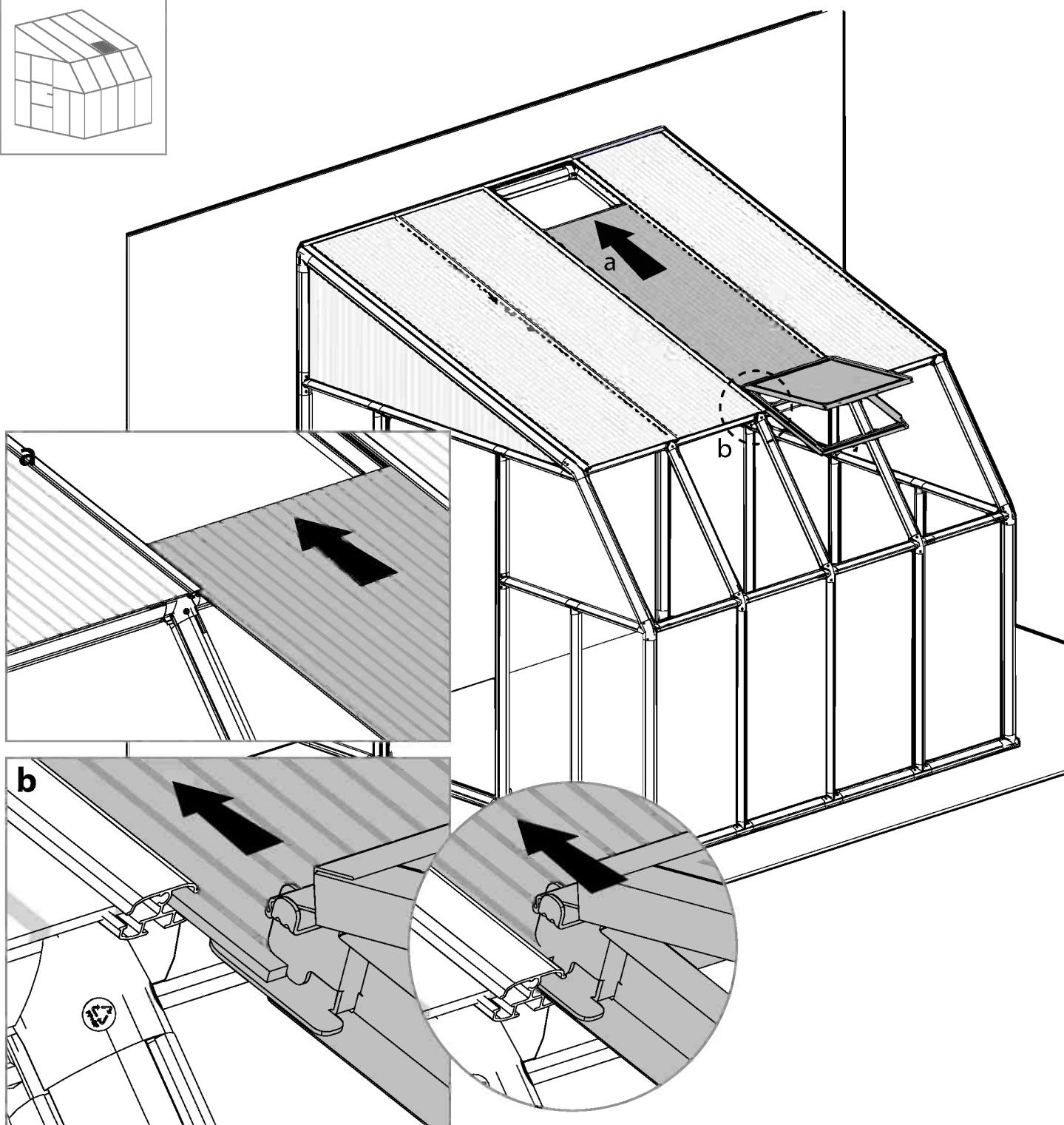
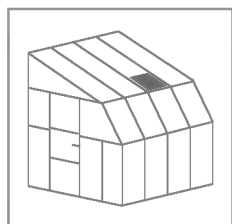

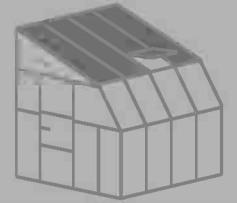

Item		Qty.
7552		3
7552 F		1

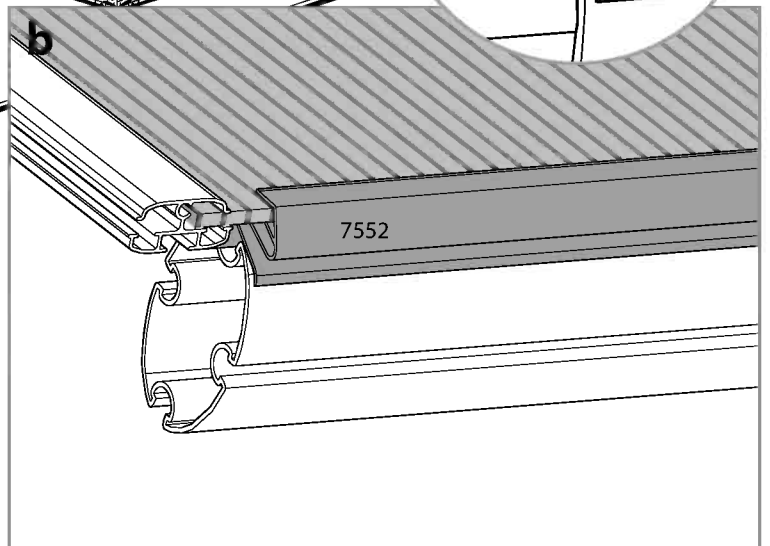
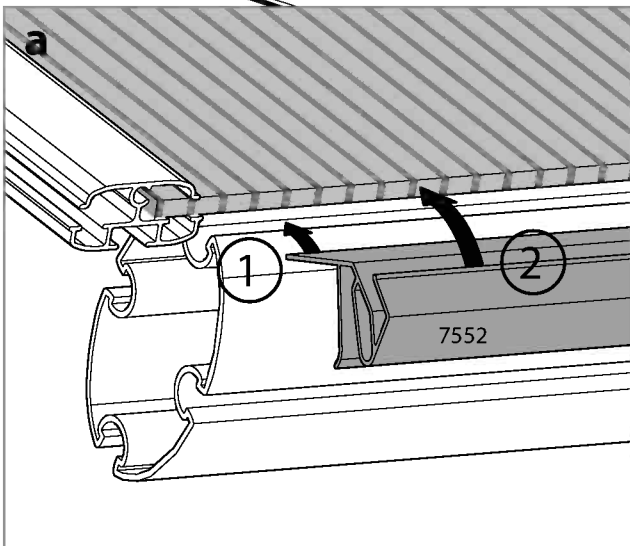
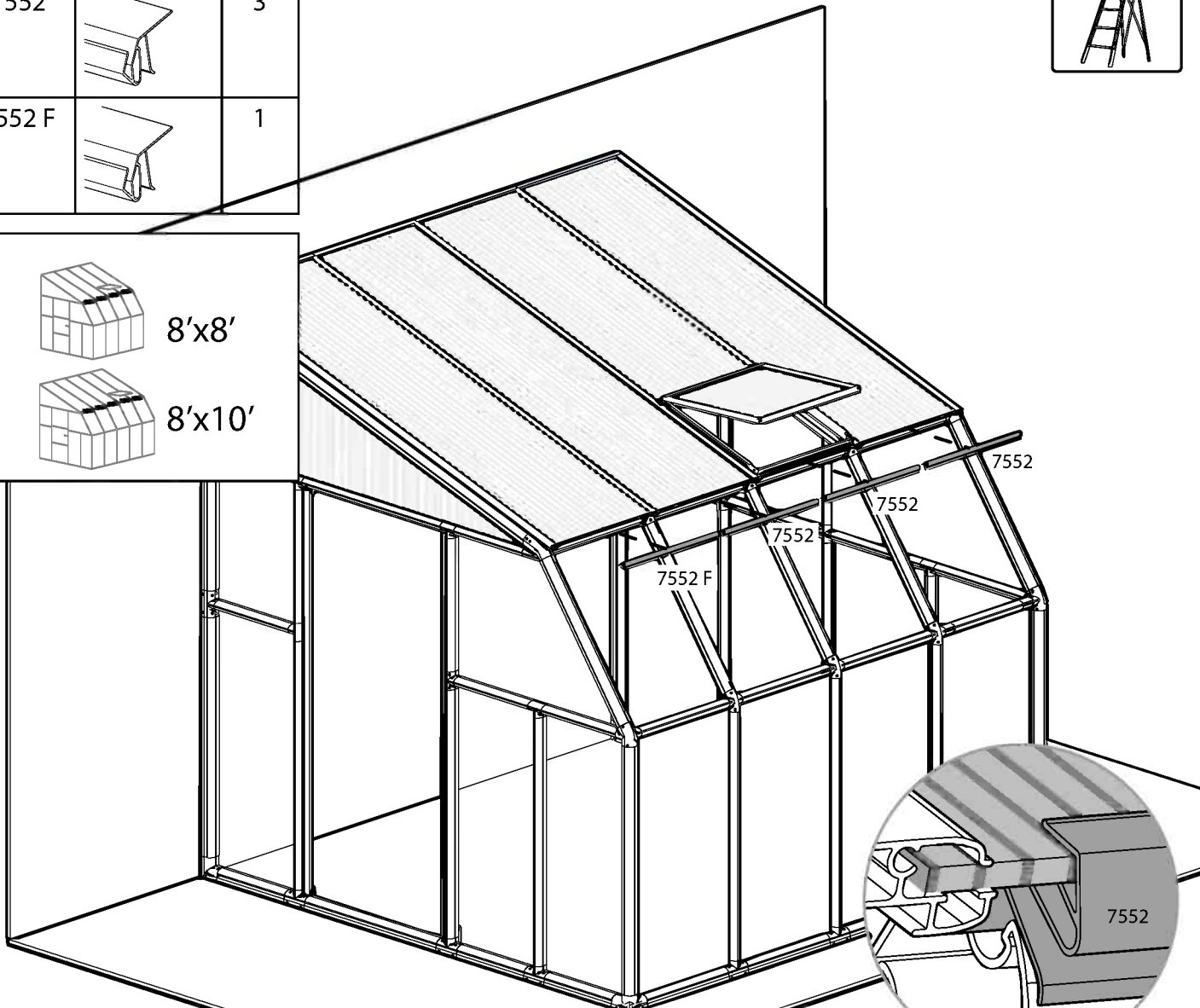
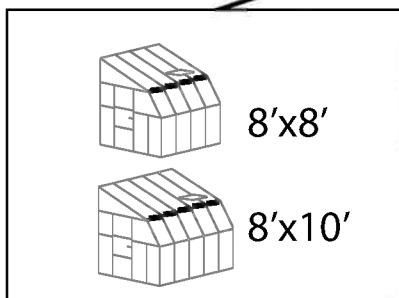

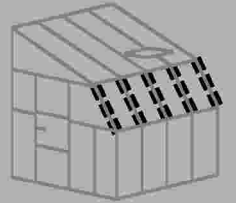

Item		Qty.
72		1
73		1
74		3
7612		2
7614		3
4043		5

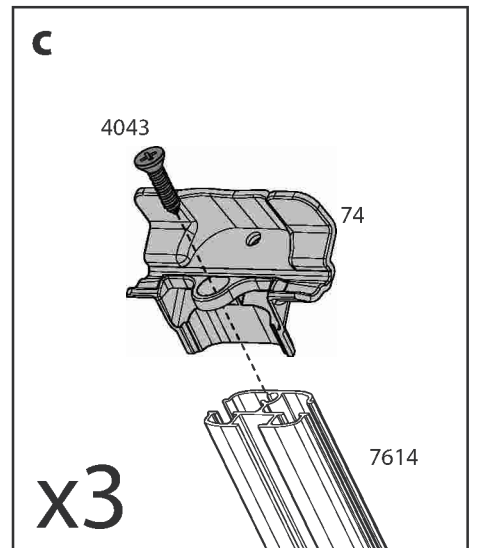
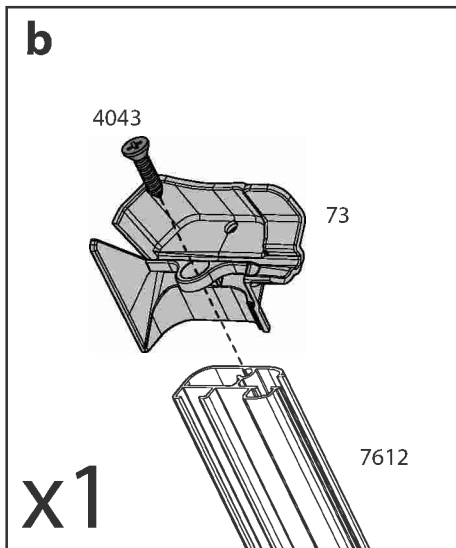
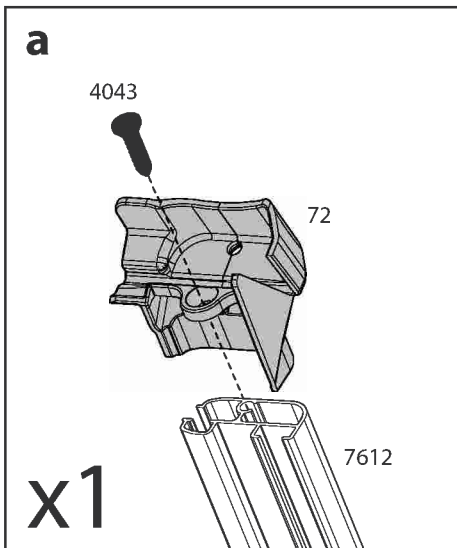
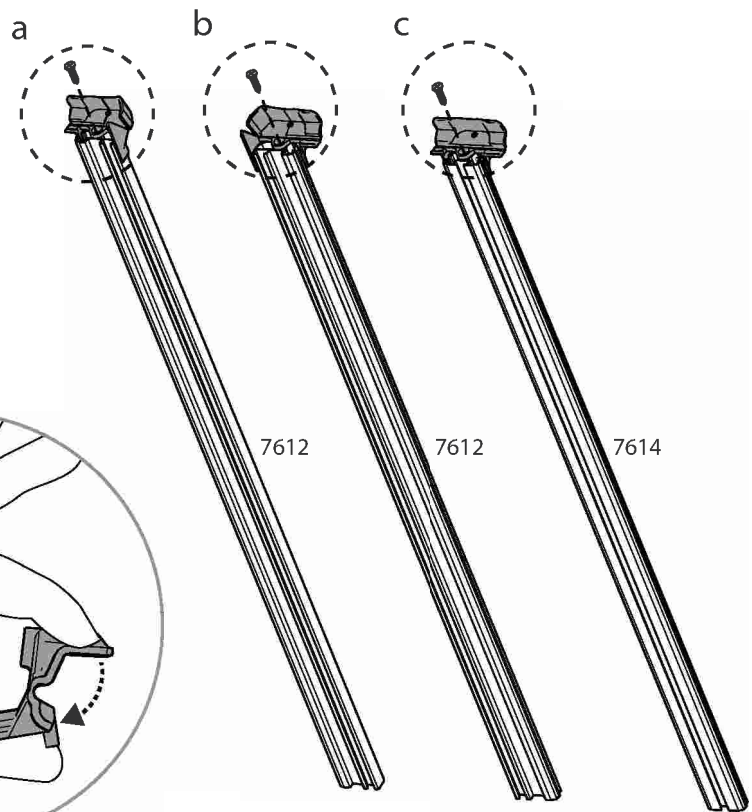
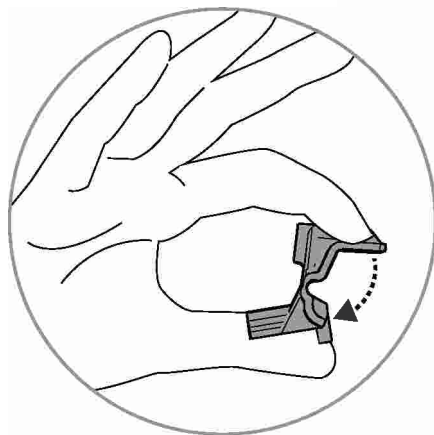
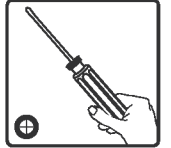
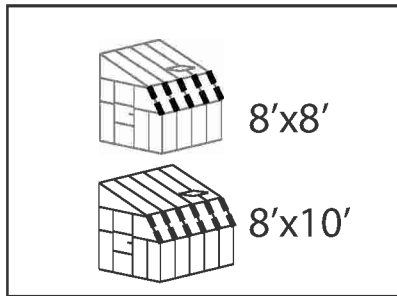

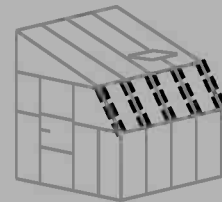

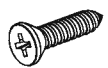

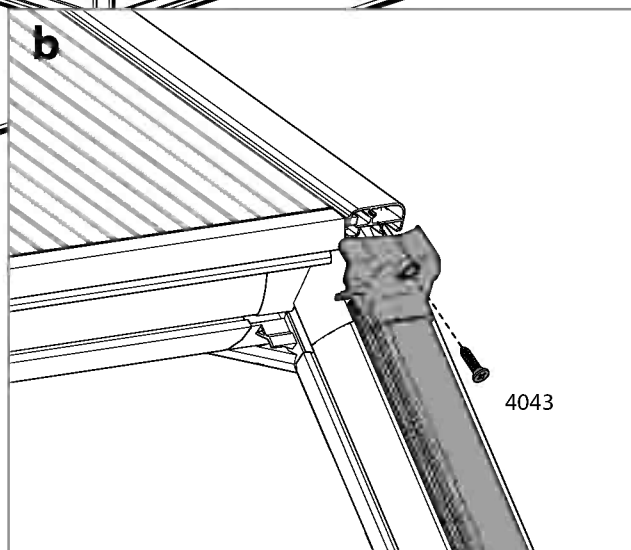
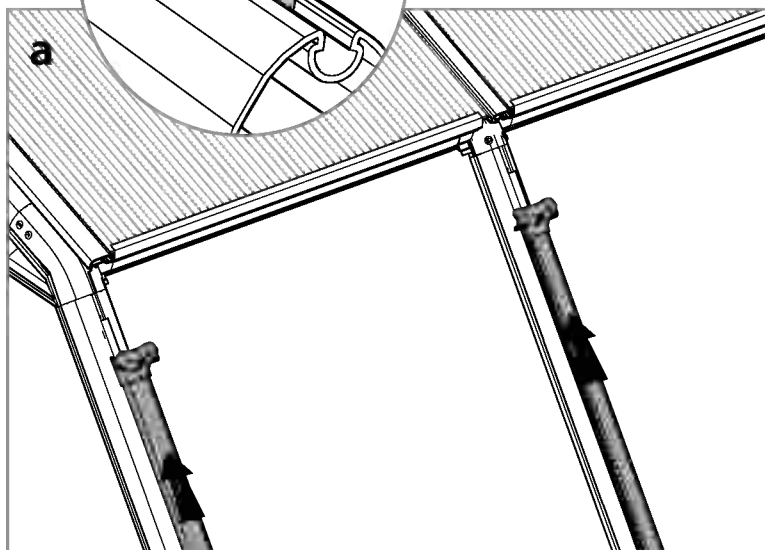
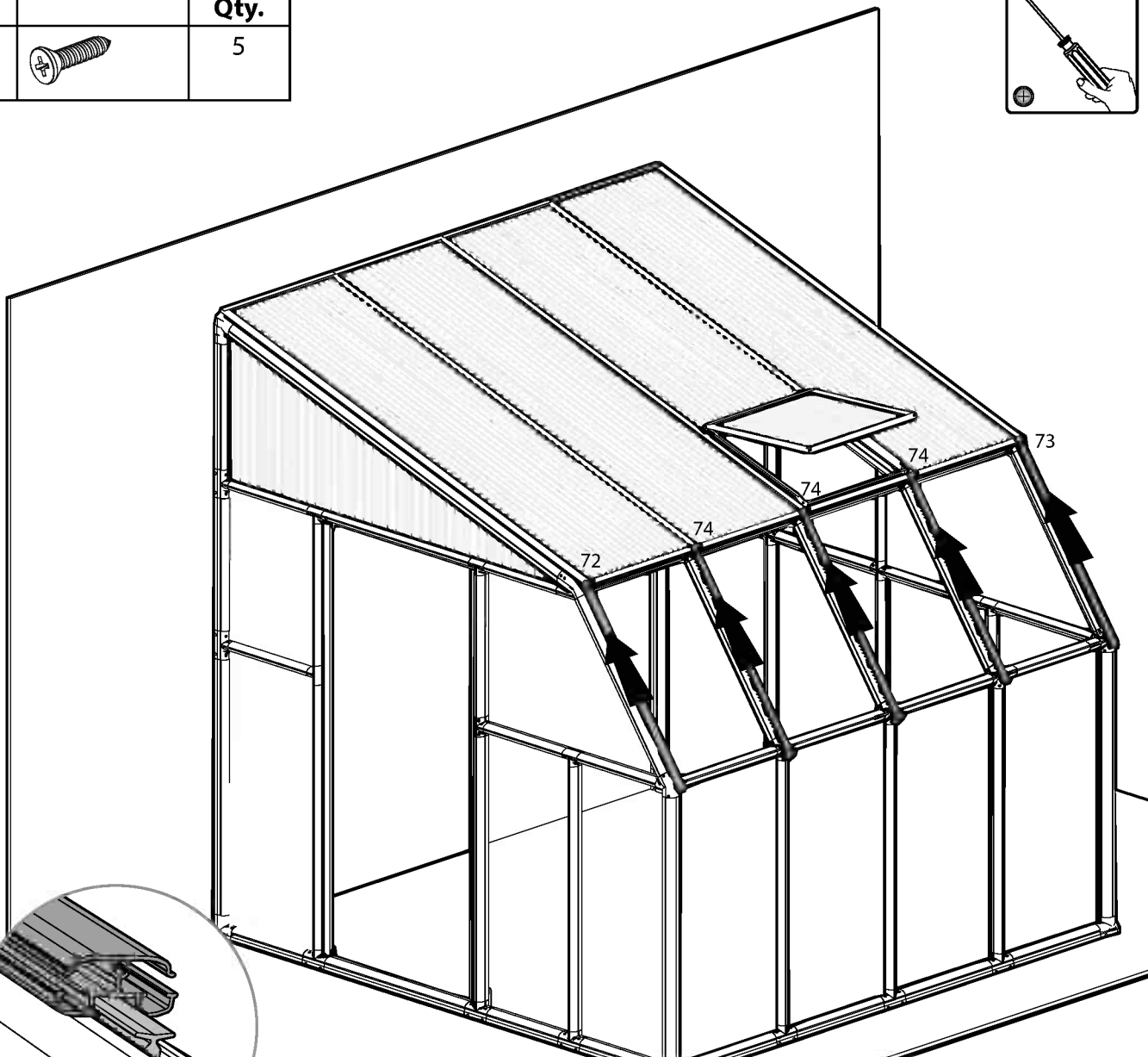
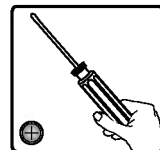

Item		Qty.
4043		5

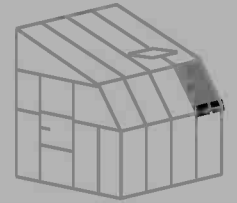

4043

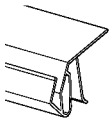
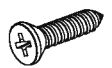

Item		Qty.
PN55		1
7552		1
4043		1
73		1

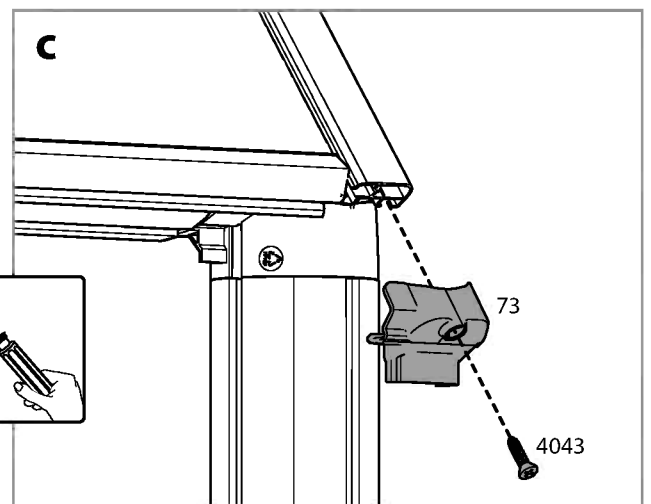
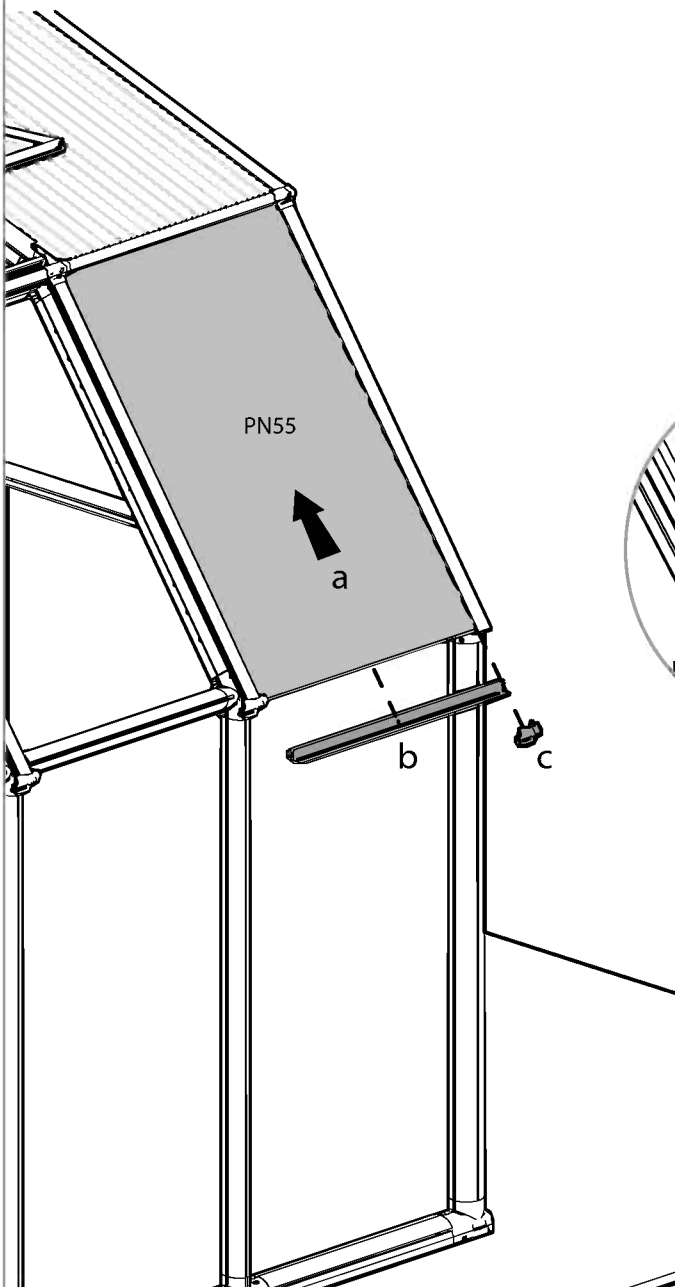
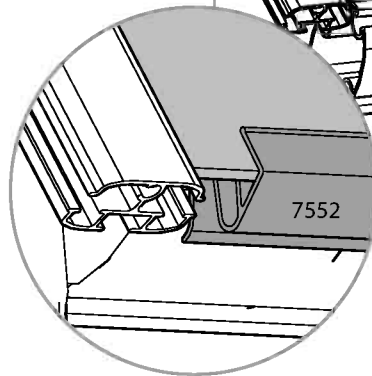
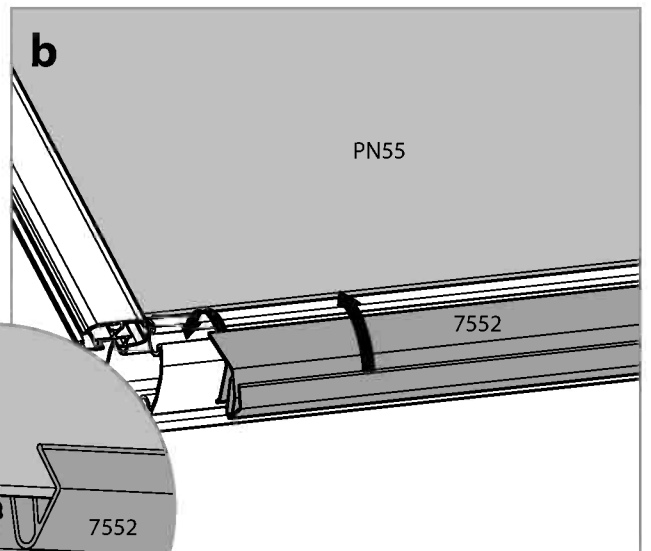
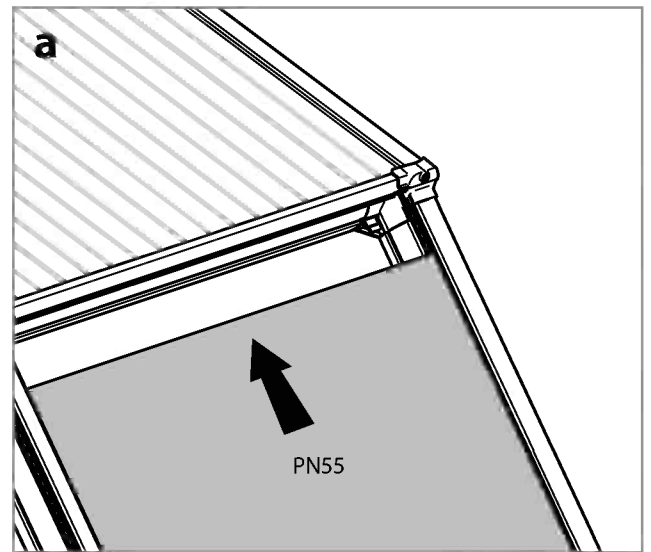

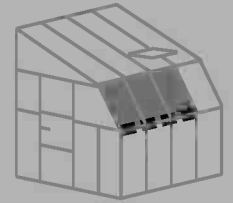

Item		Qty.
PN55		3
7552		2
7552 F		1

Item		Qty.
4043		4
72		1
74		3

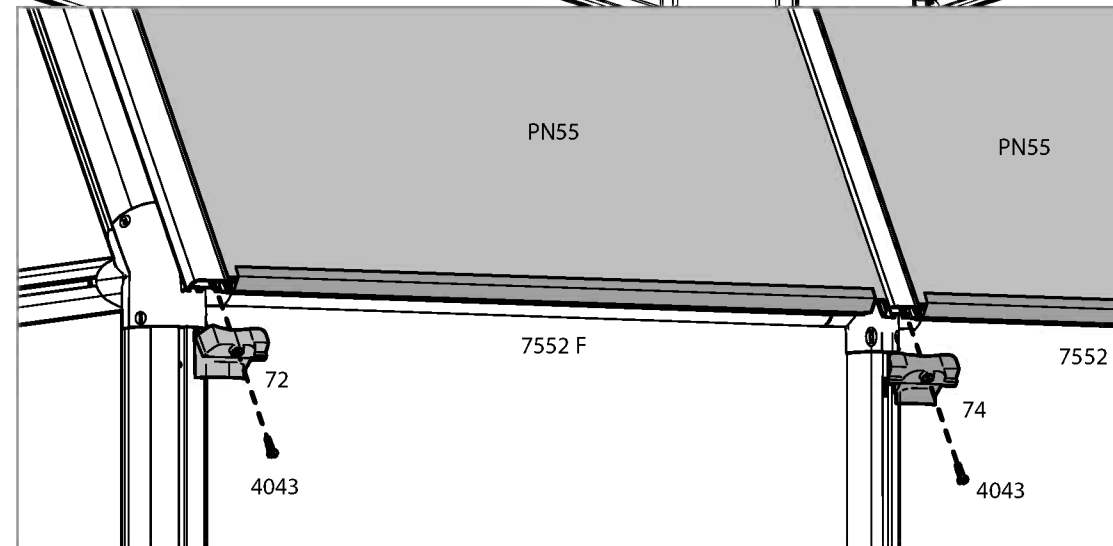
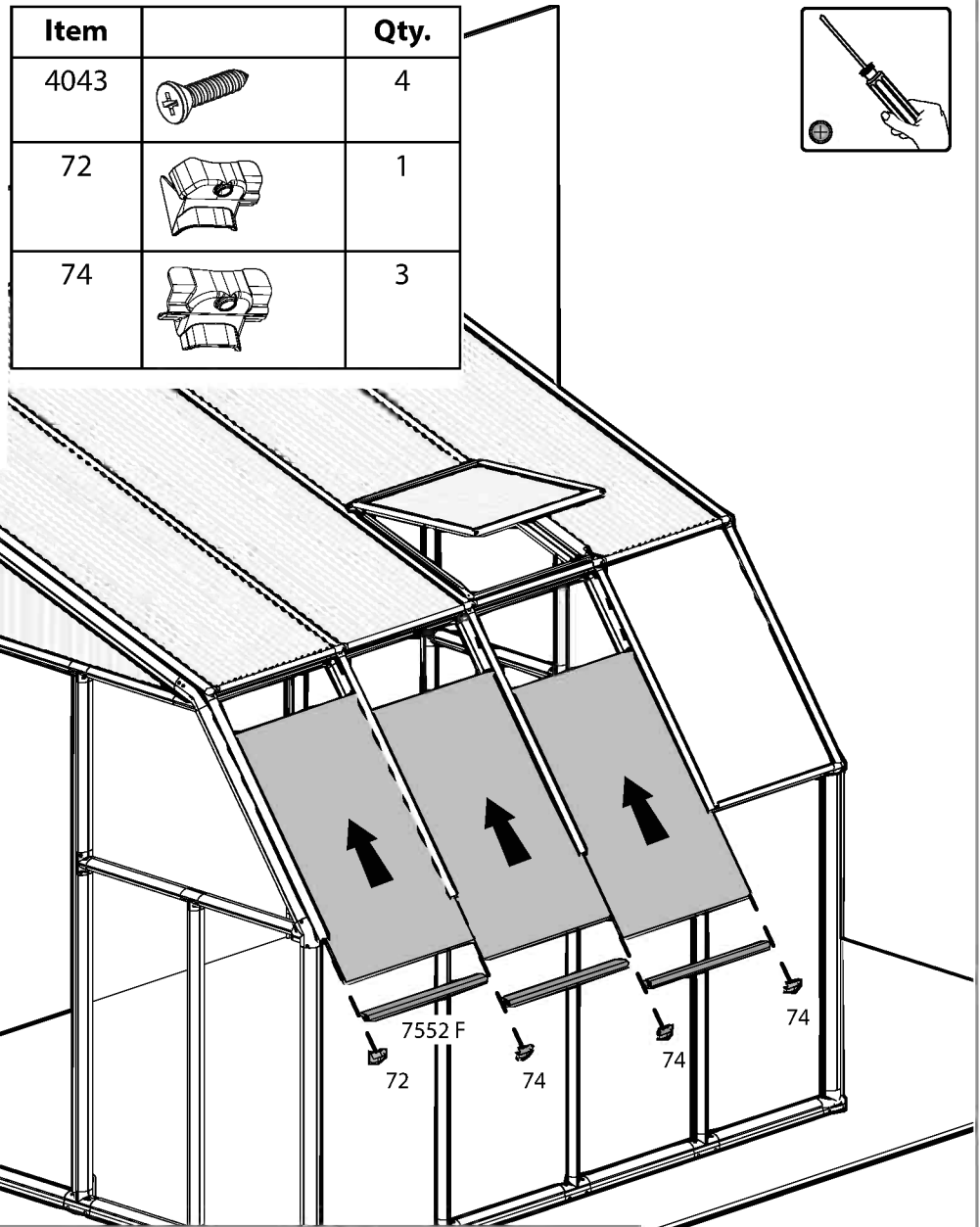
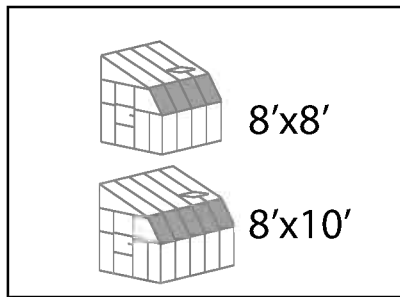
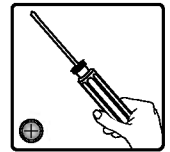

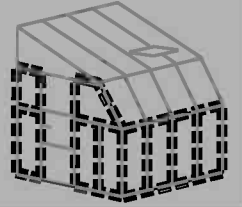

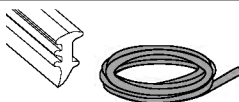
Item		Qty.
GF		

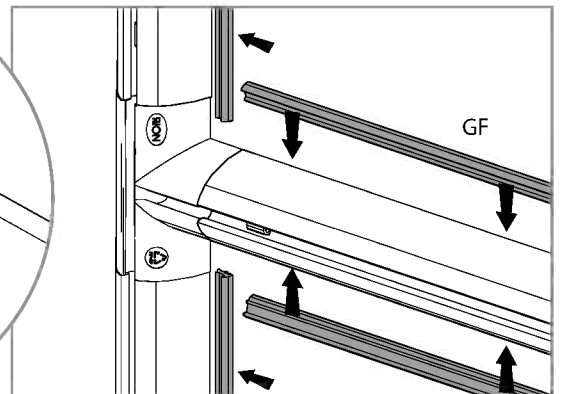
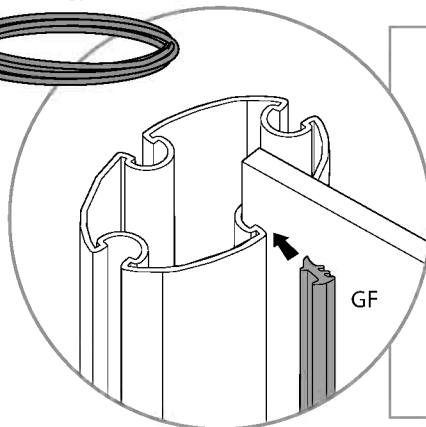
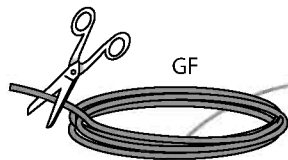
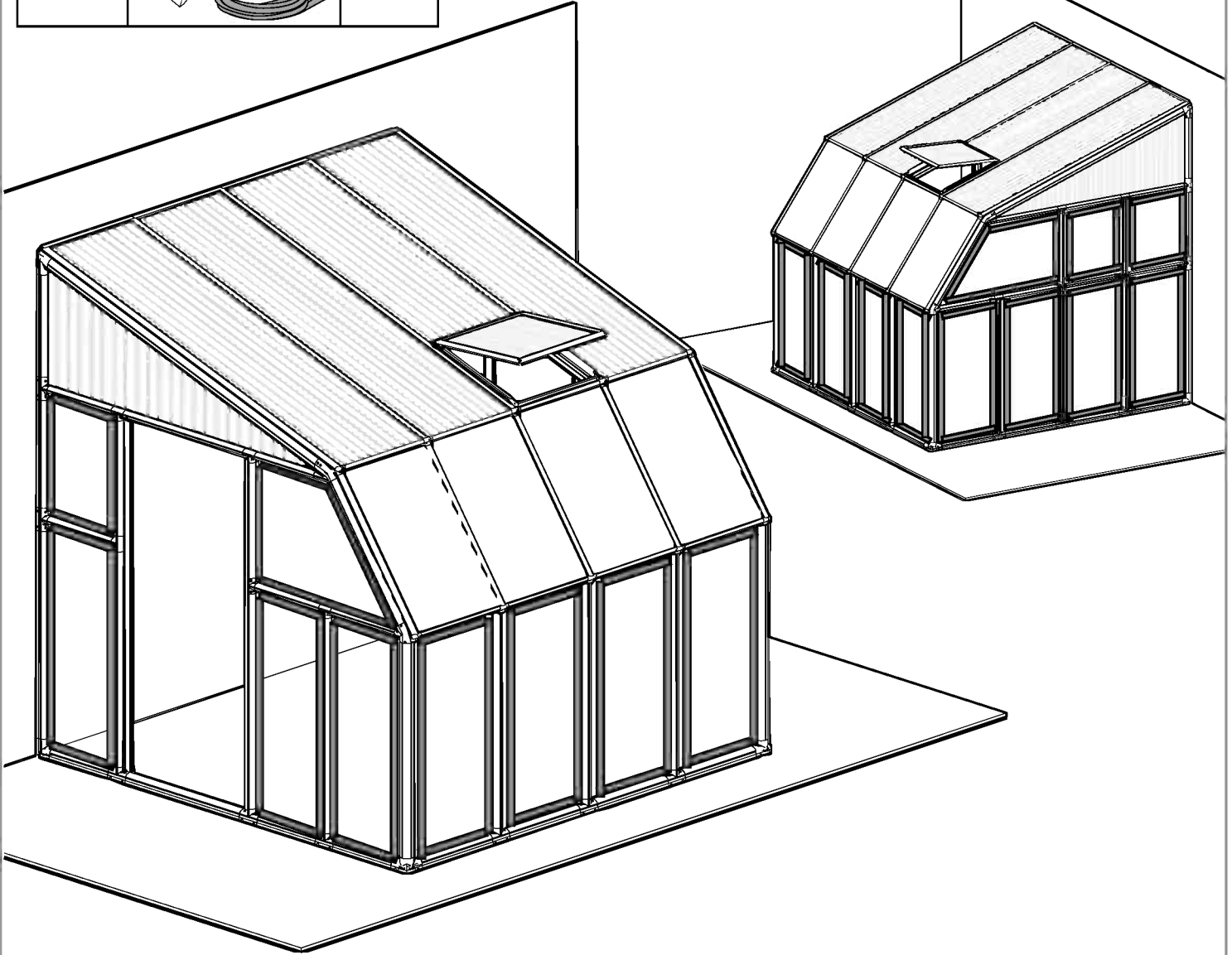

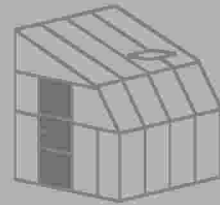

Item		Qty.
7949		1
7950		1

Item		Qty.
7952		2
7445		2

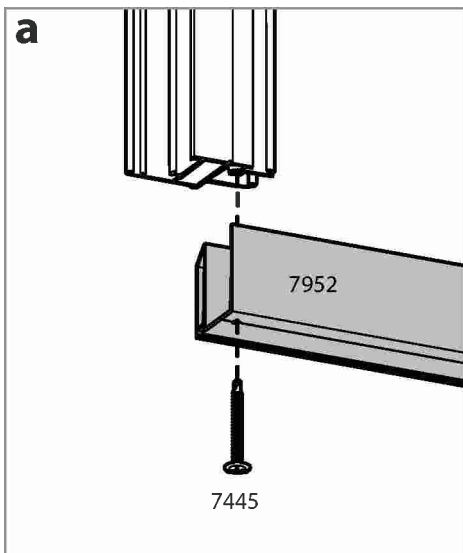
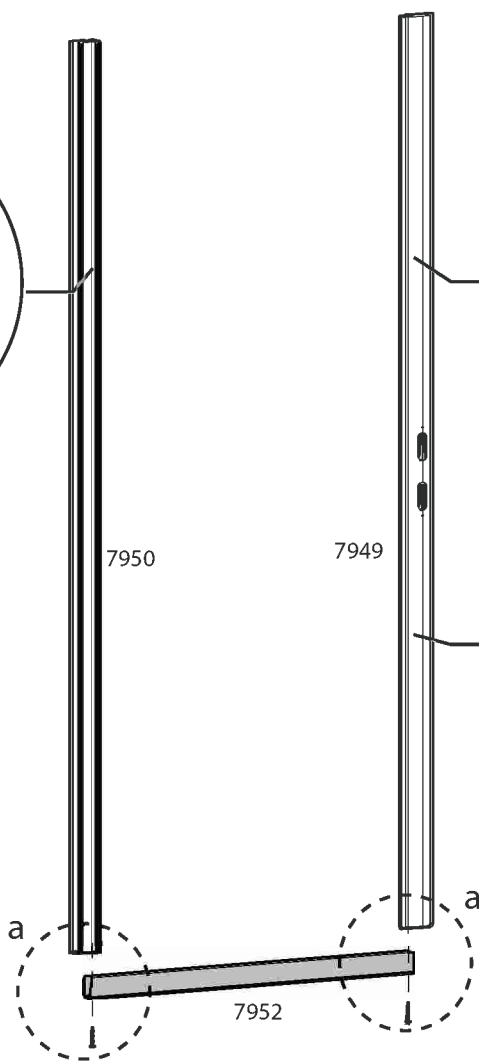
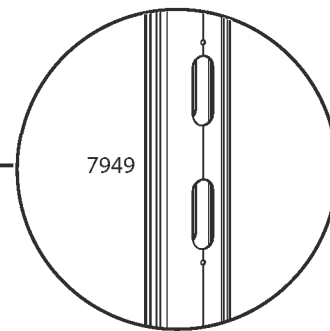
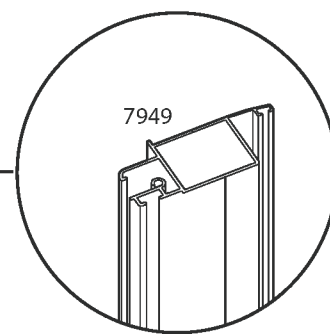
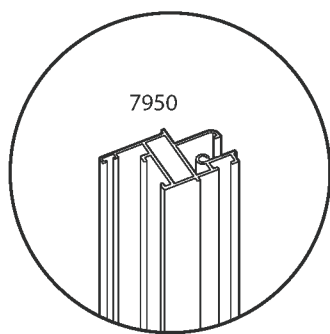
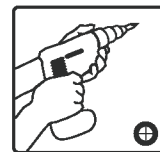

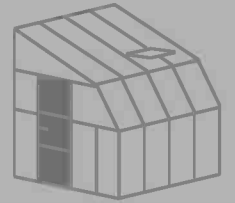

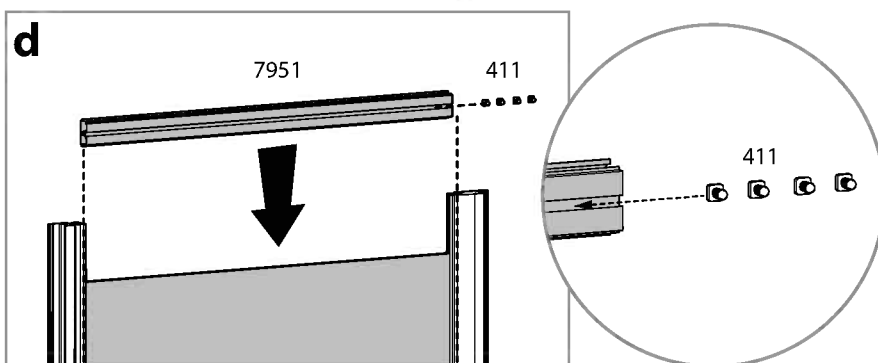
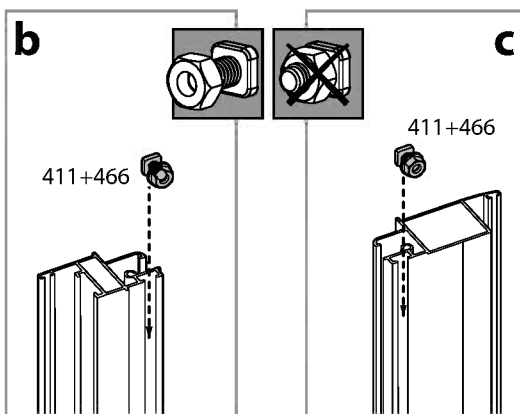
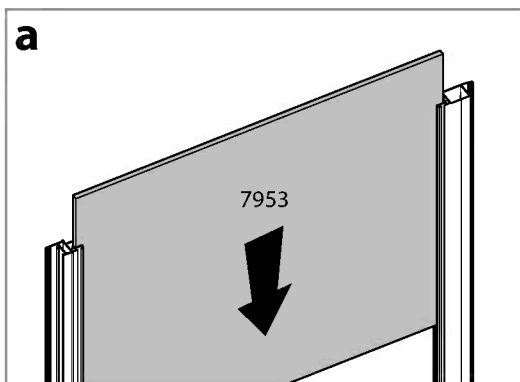
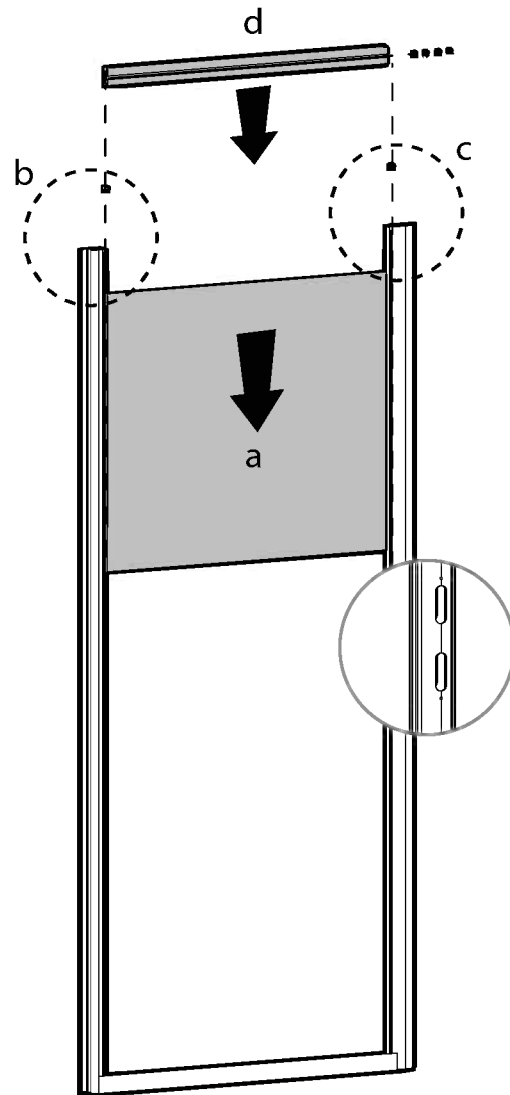

Item		Qty.
7953		1
7951		1
411		6
466		2

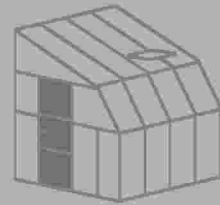

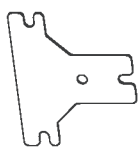

Item		Qty.
7898		2
466		8
411		4

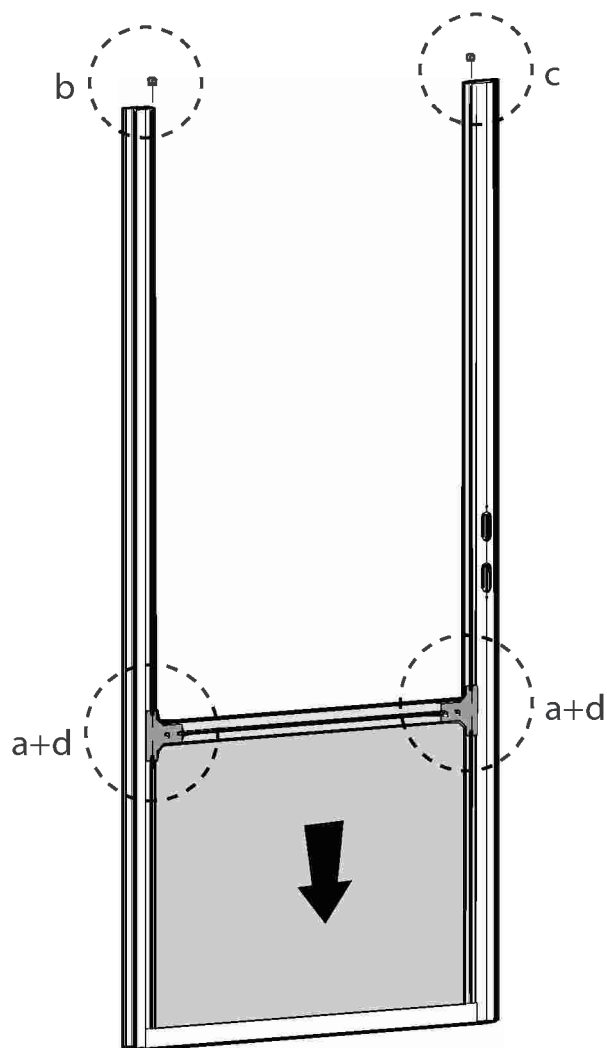
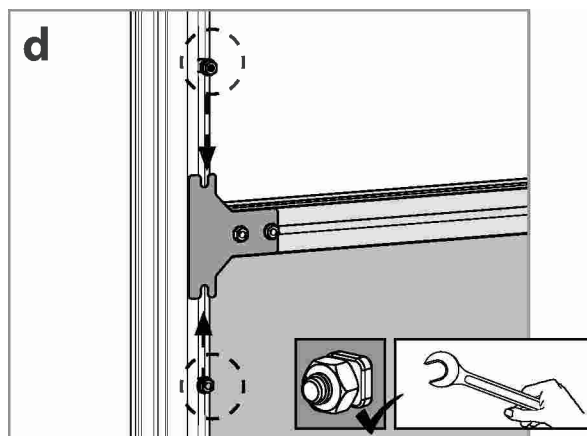
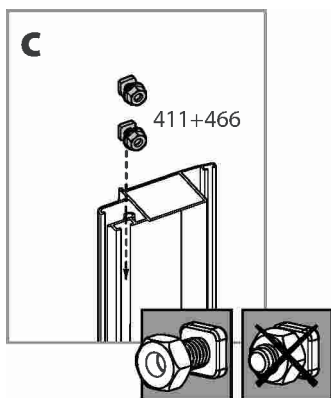
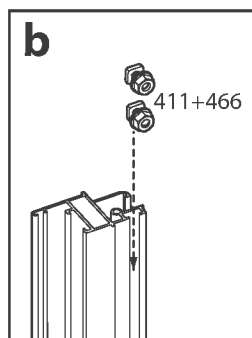
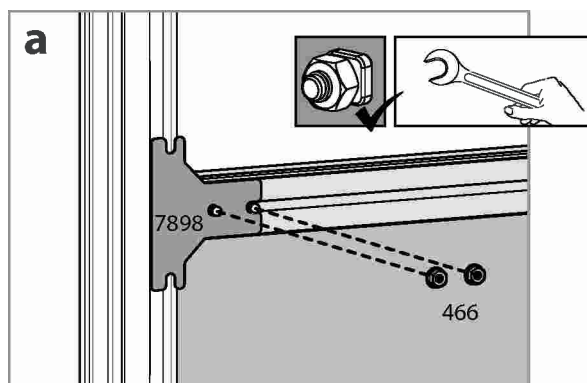

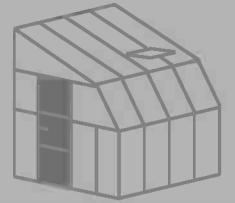

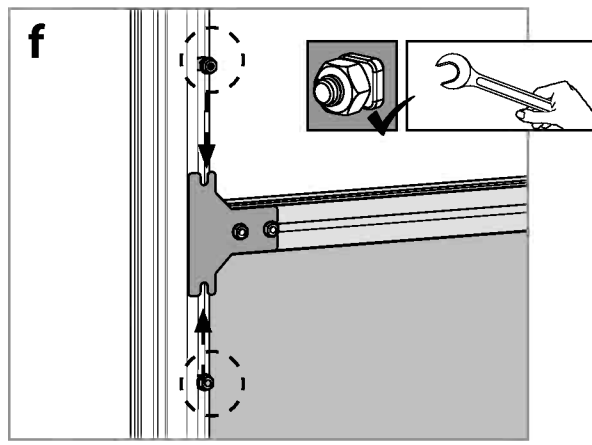
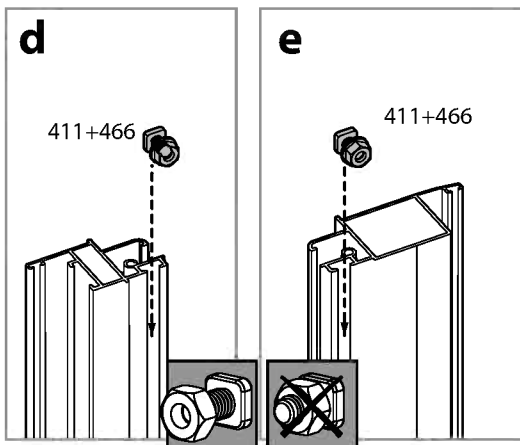
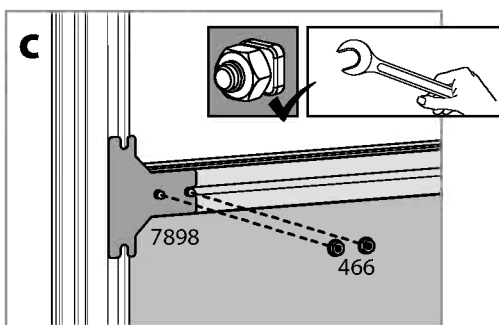
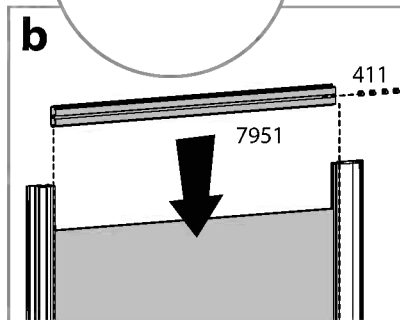
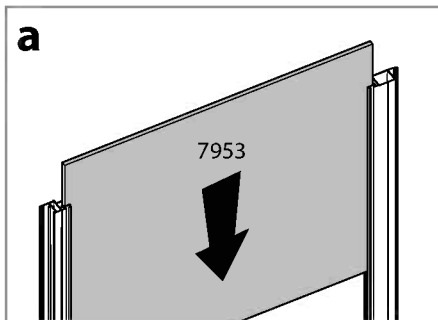
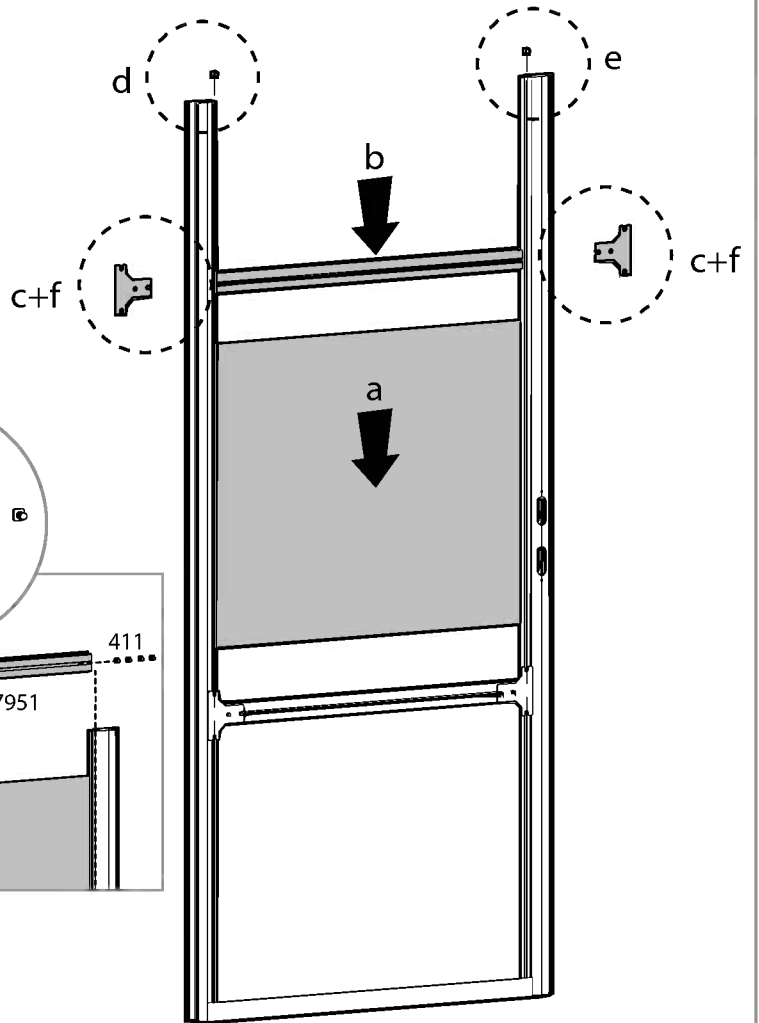

Item		Qty.
7953		1
7951		1
7898		2
411		6
466		6

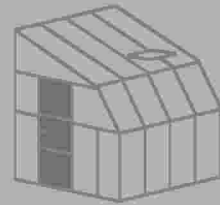

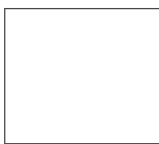
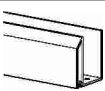

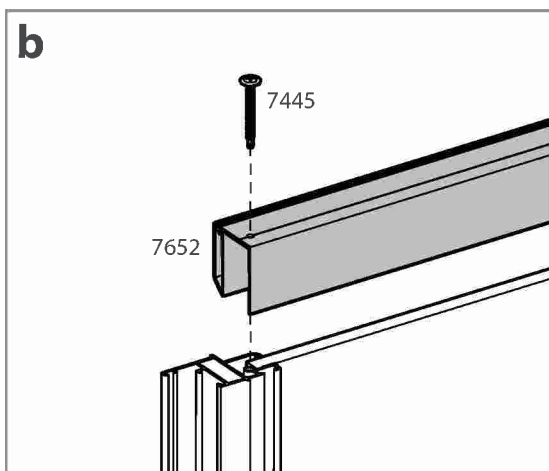
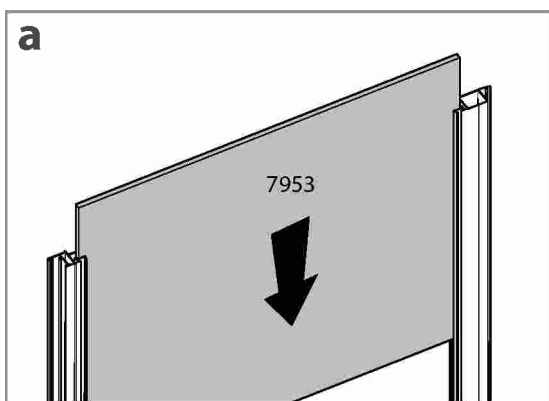
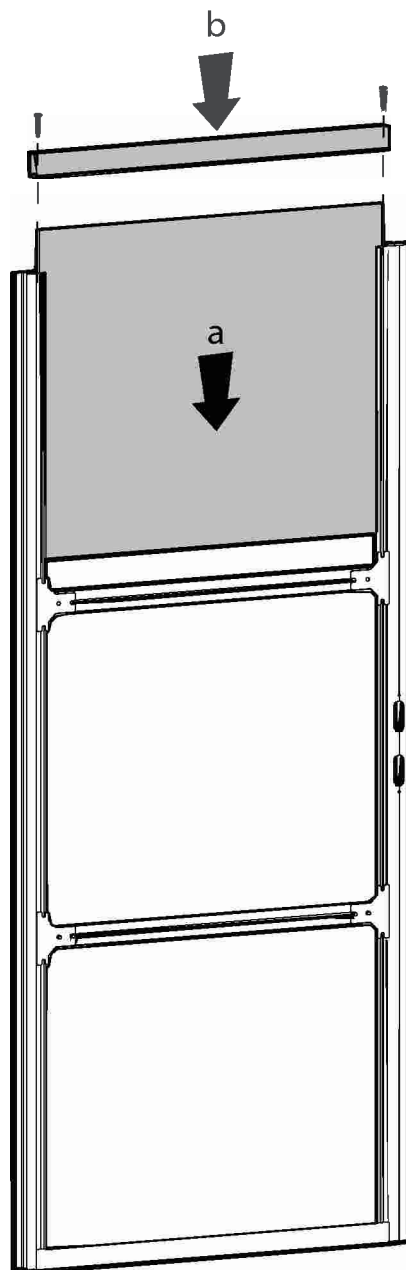

Item		Qty.
7953		1
7952		1
7445		2

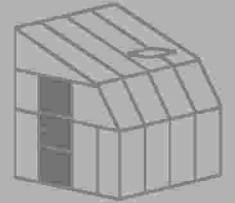

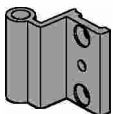

Item		Qty.
7918		2
7920		2
7924		4

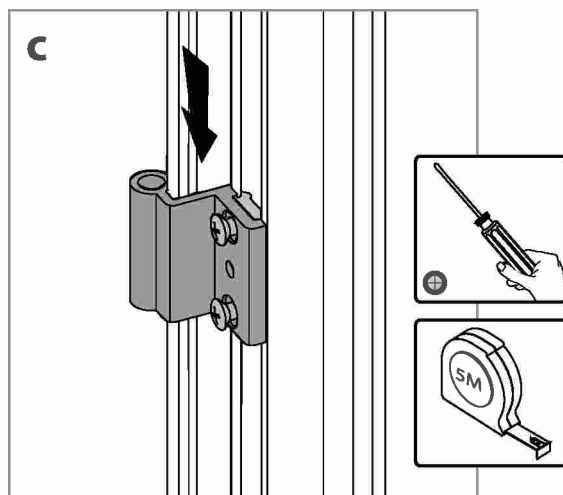
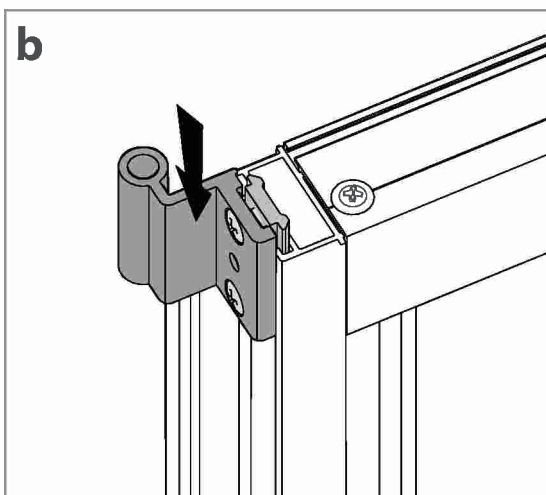
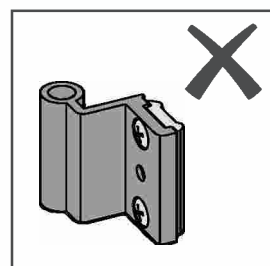
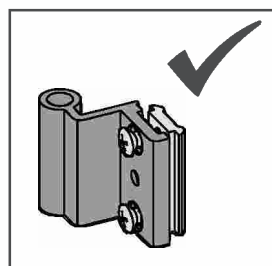
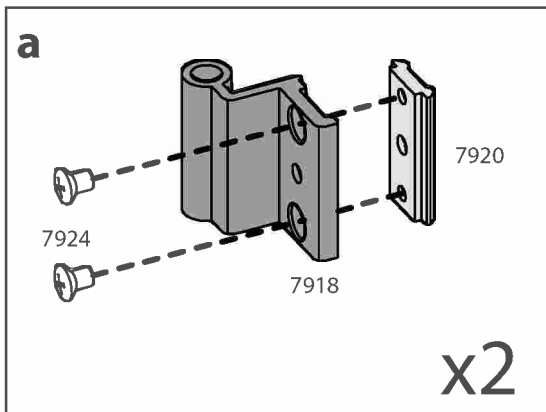
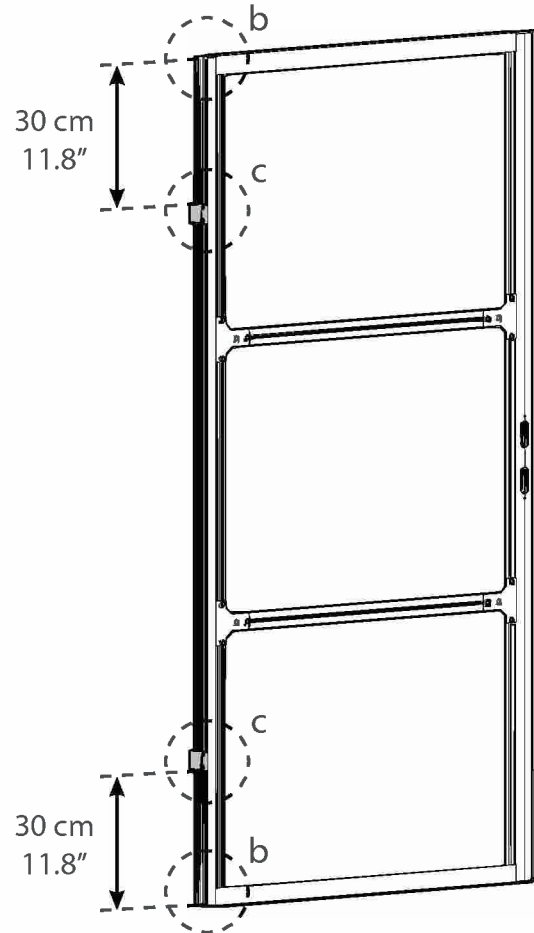

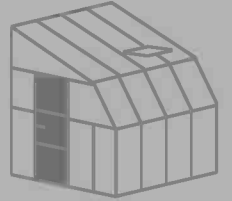

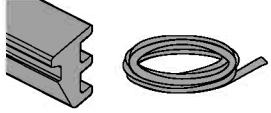
Item		Qty.
7869		

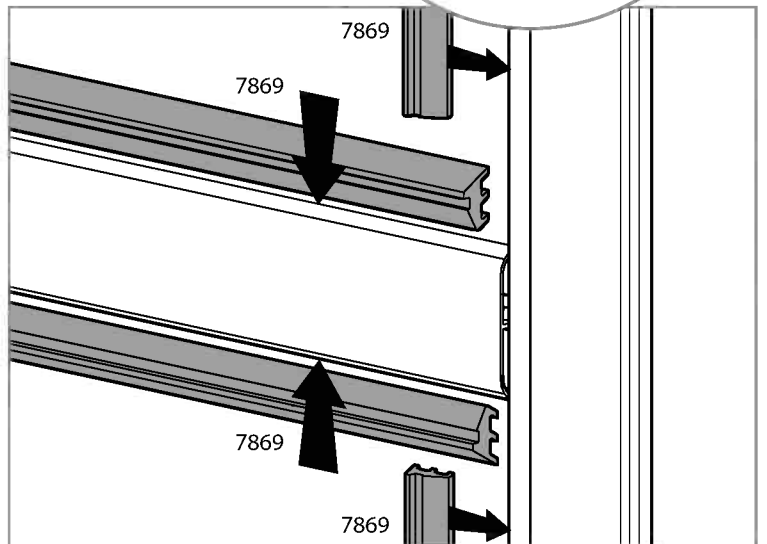
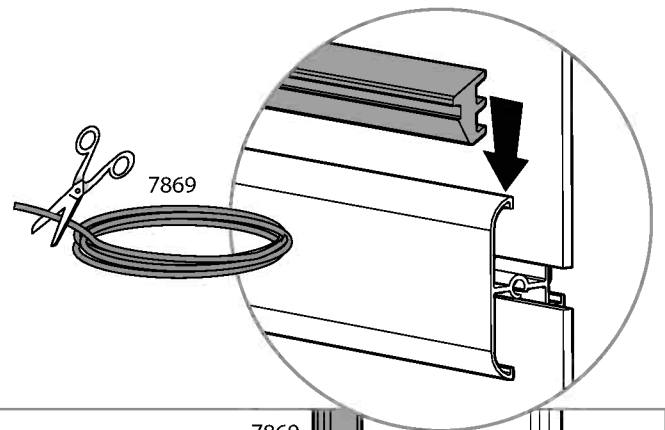
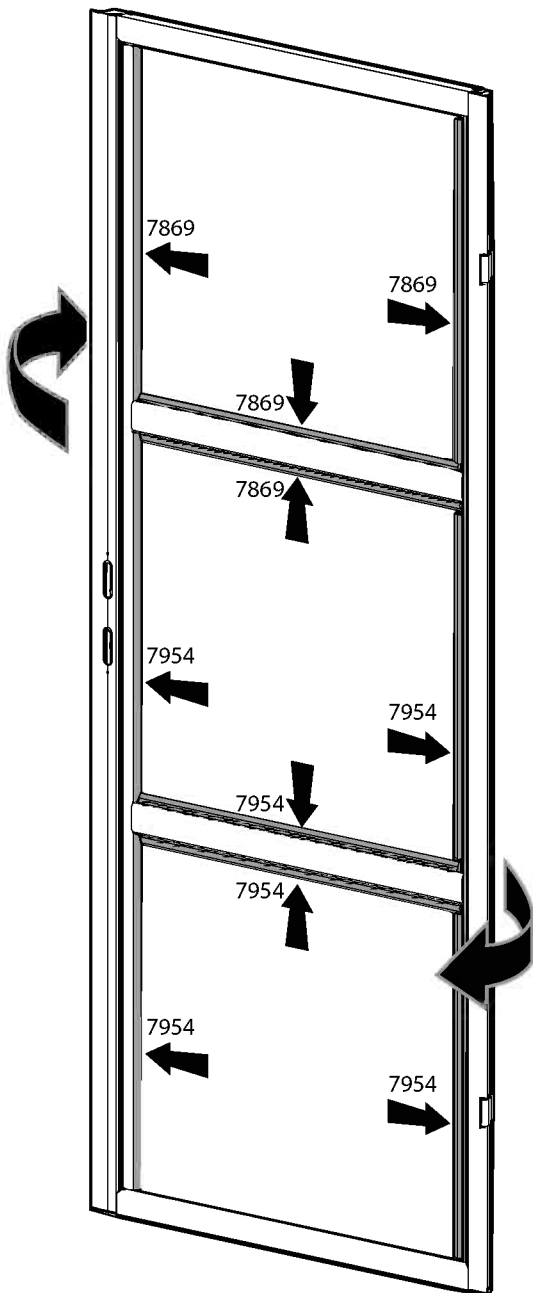
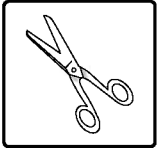

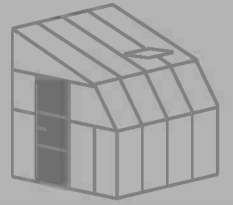



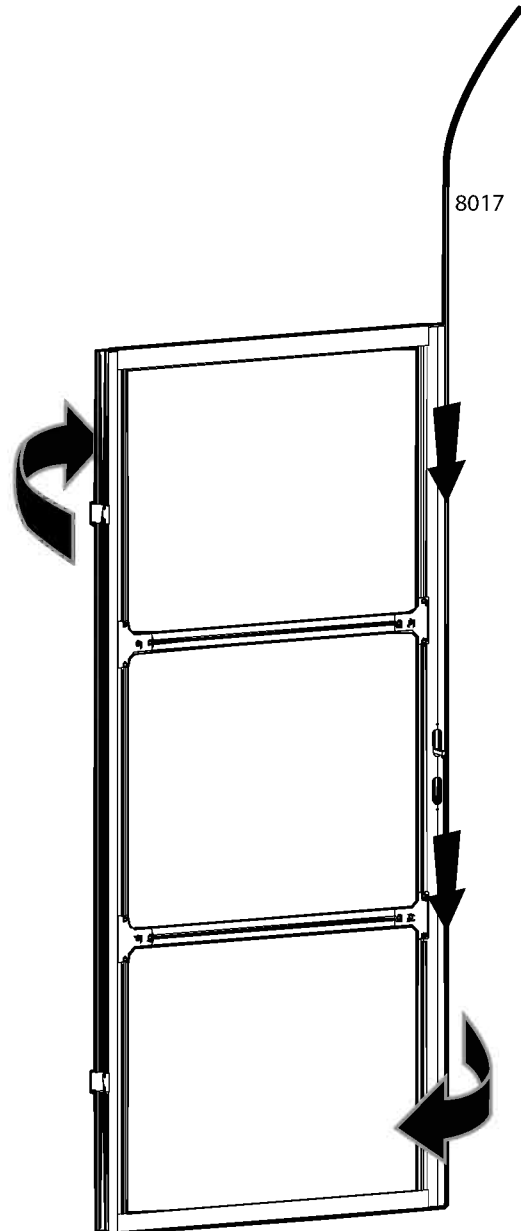
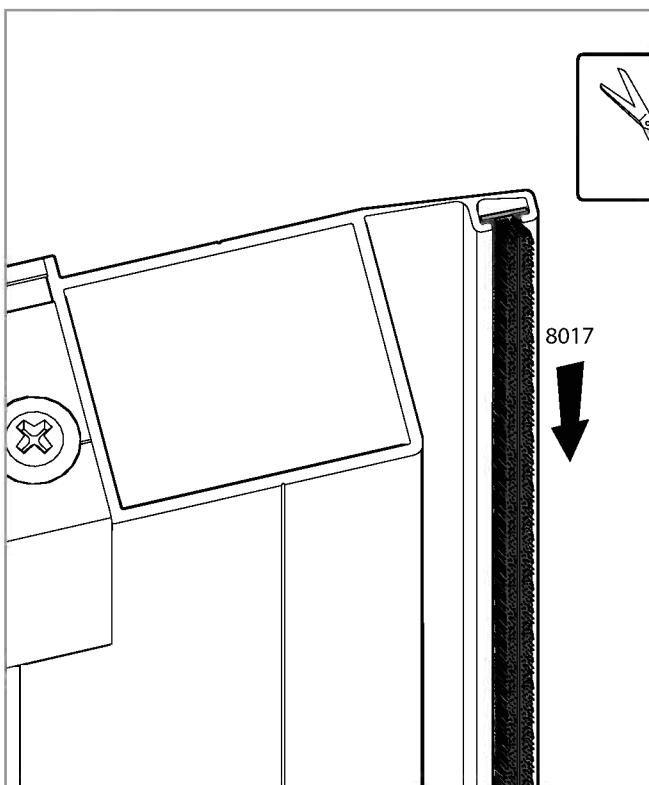

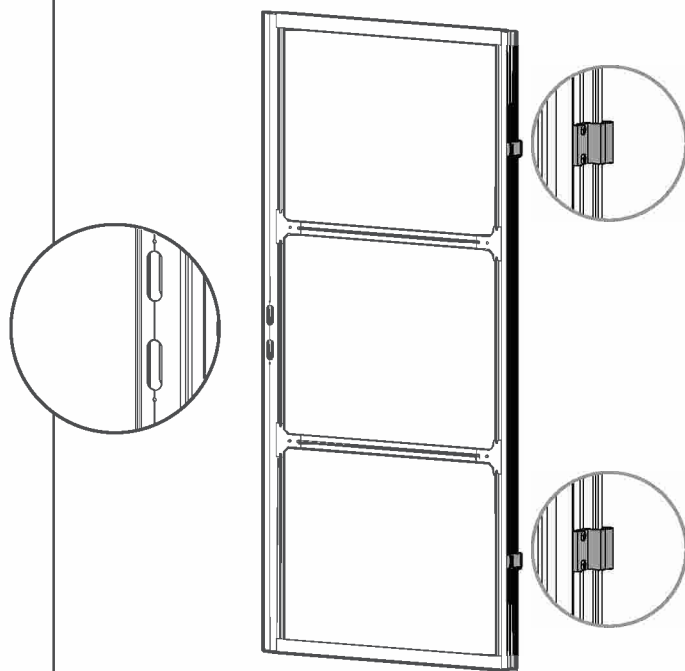
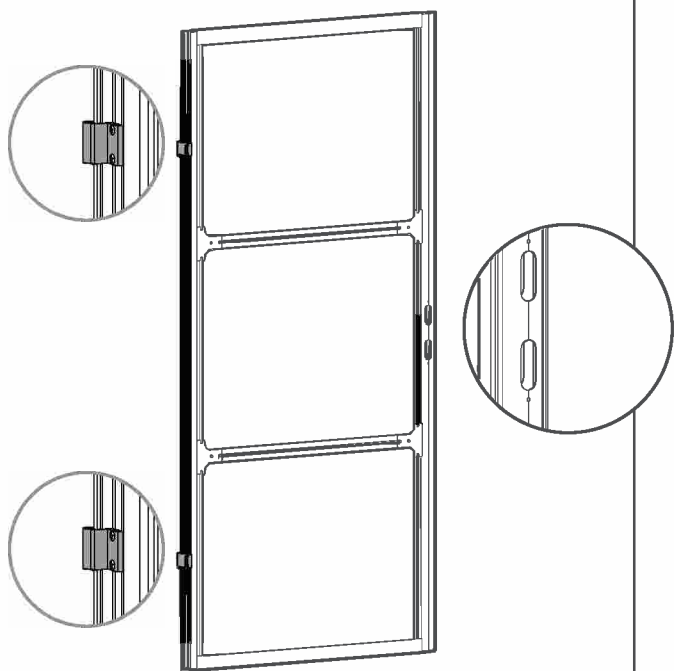
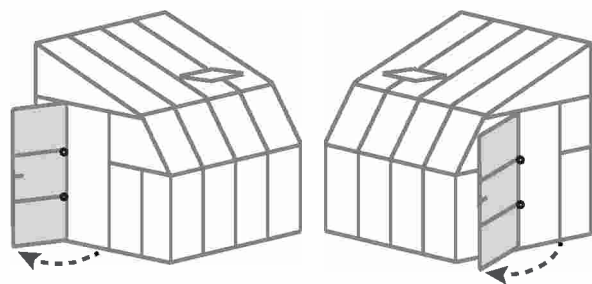
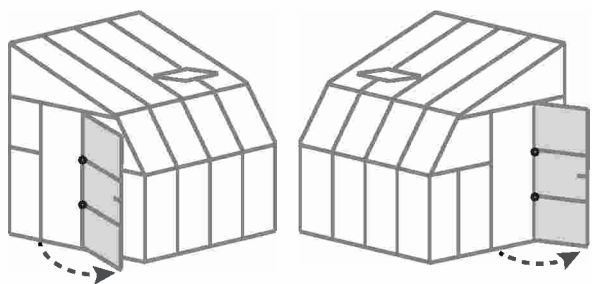

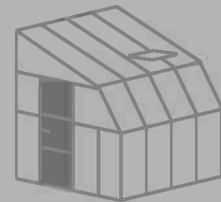
Item		Qty.
8017		1



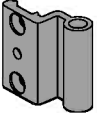



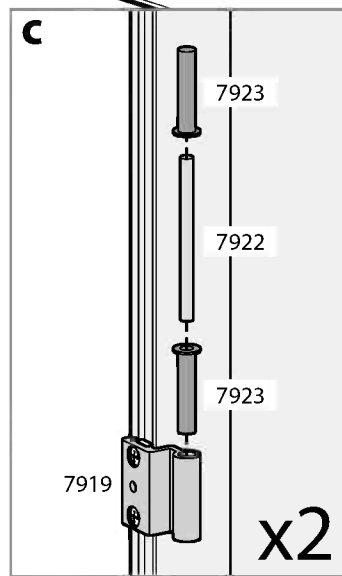
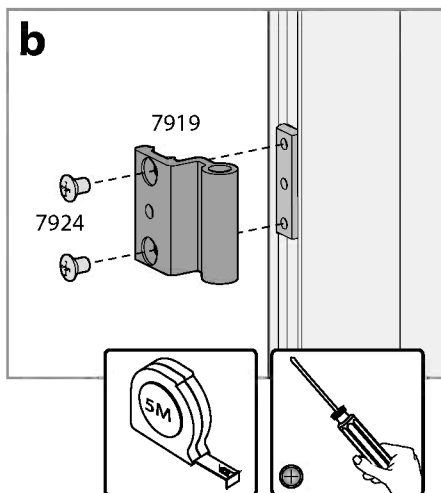
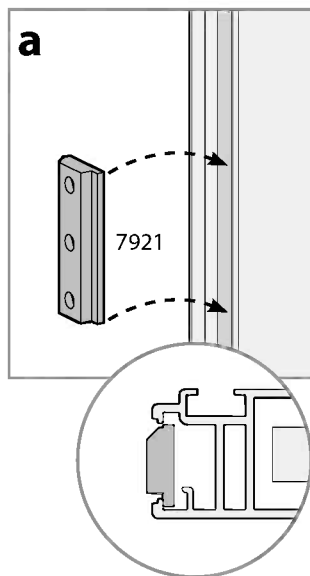
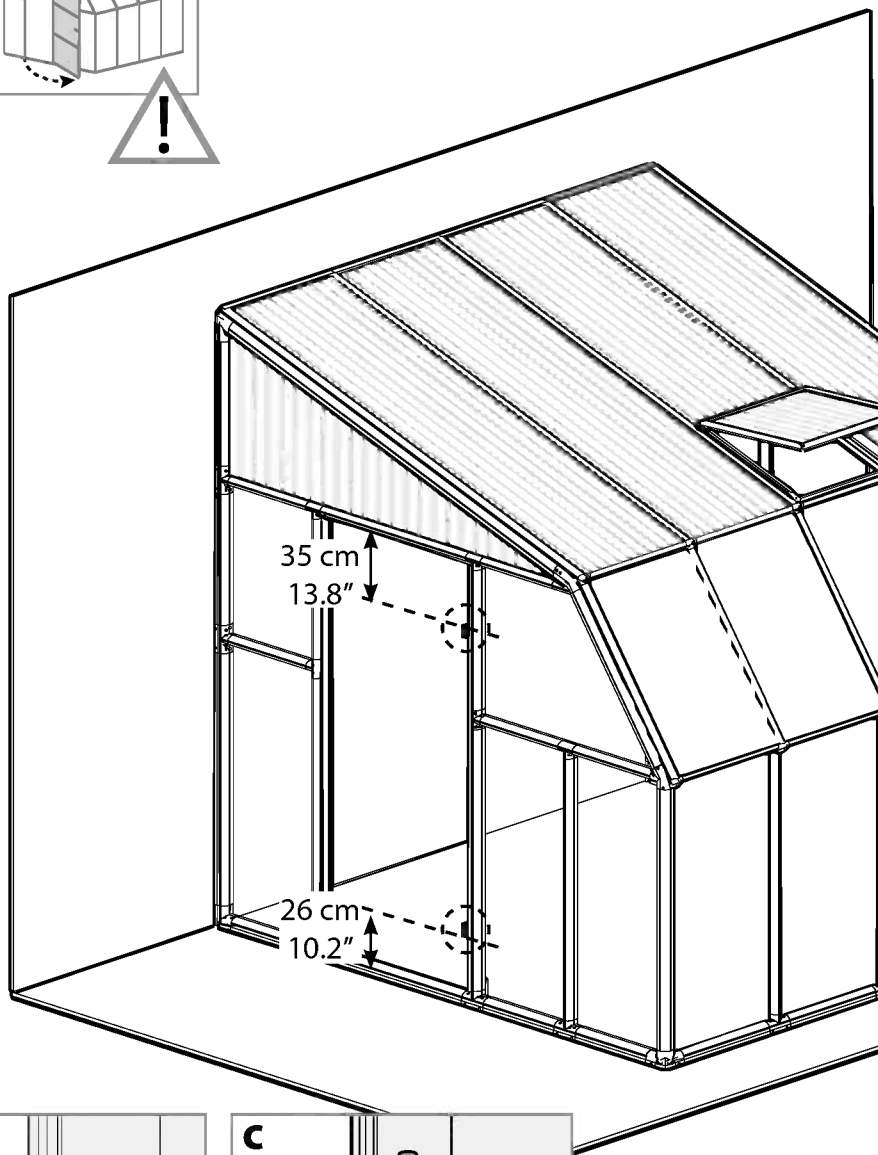
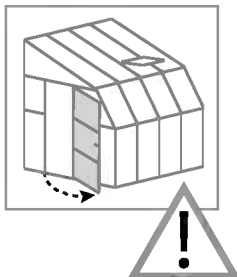

Item		Qty.
7923		4
7919		2
7921		2
7922		2
7924		4

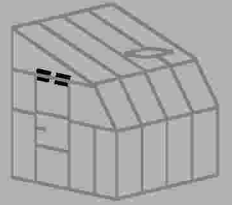





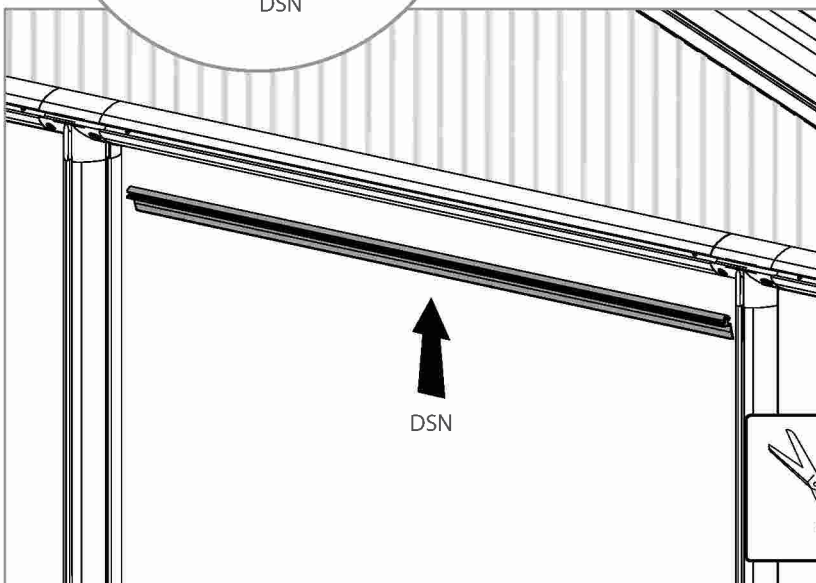
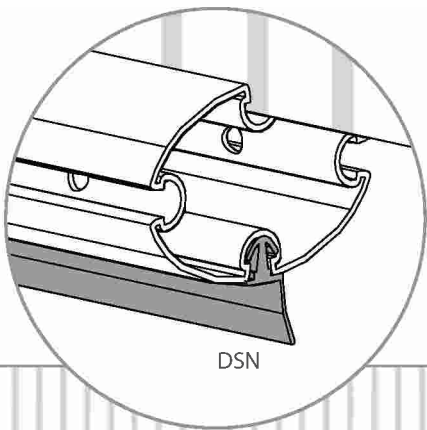
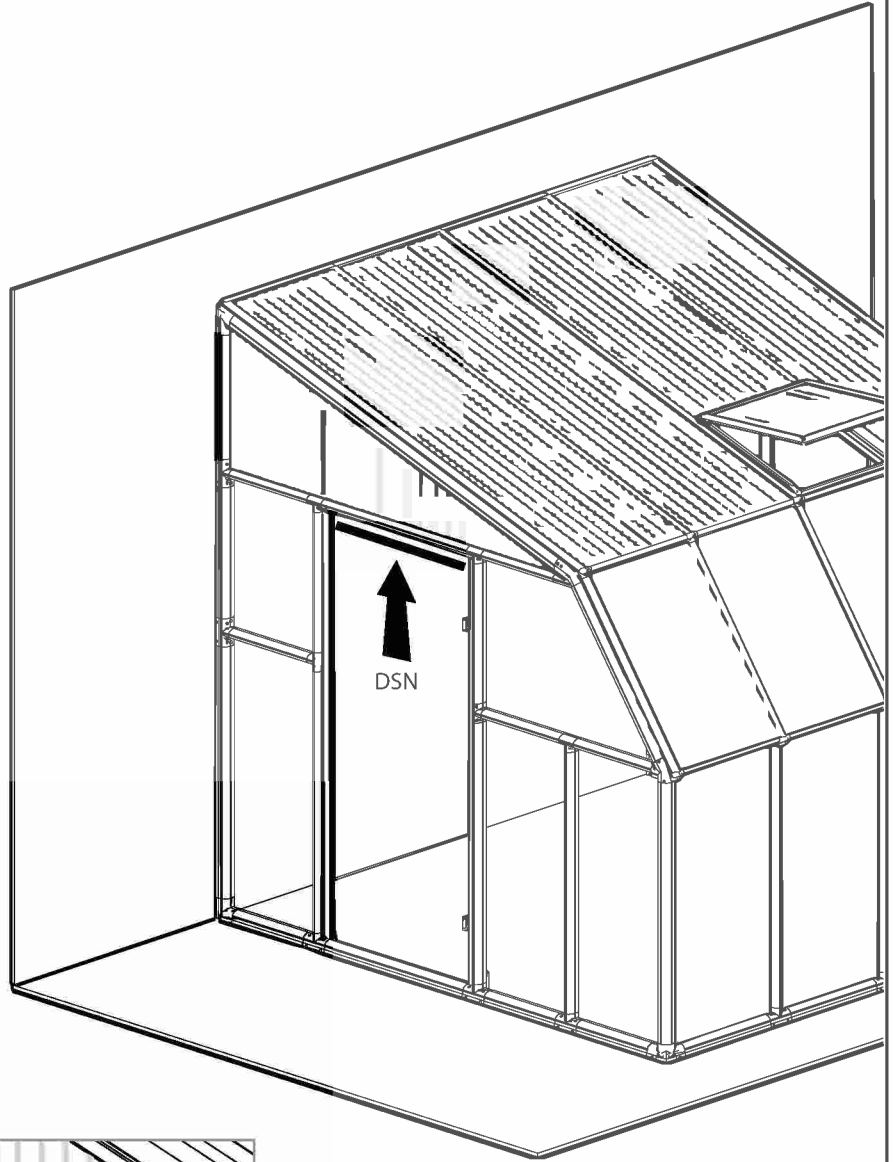

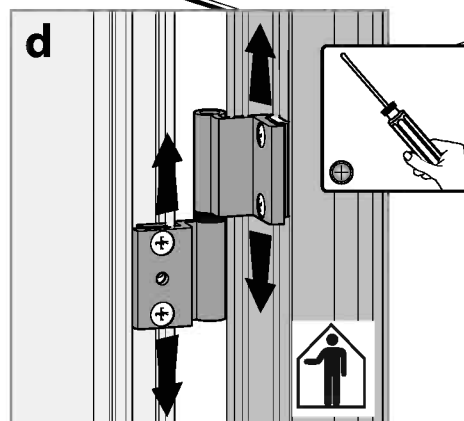
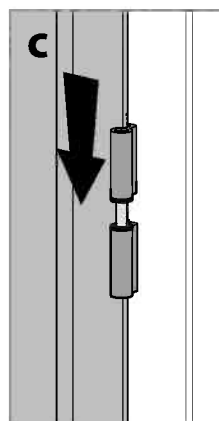
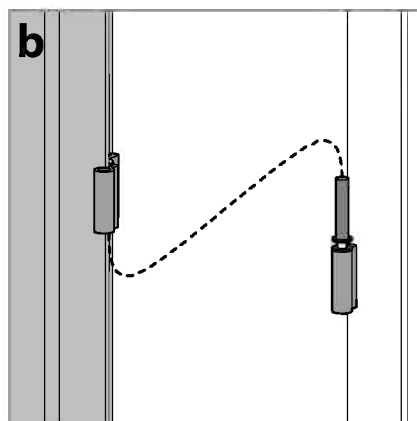
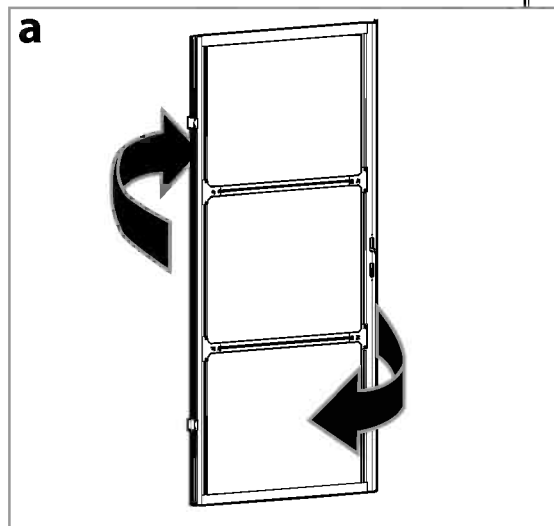
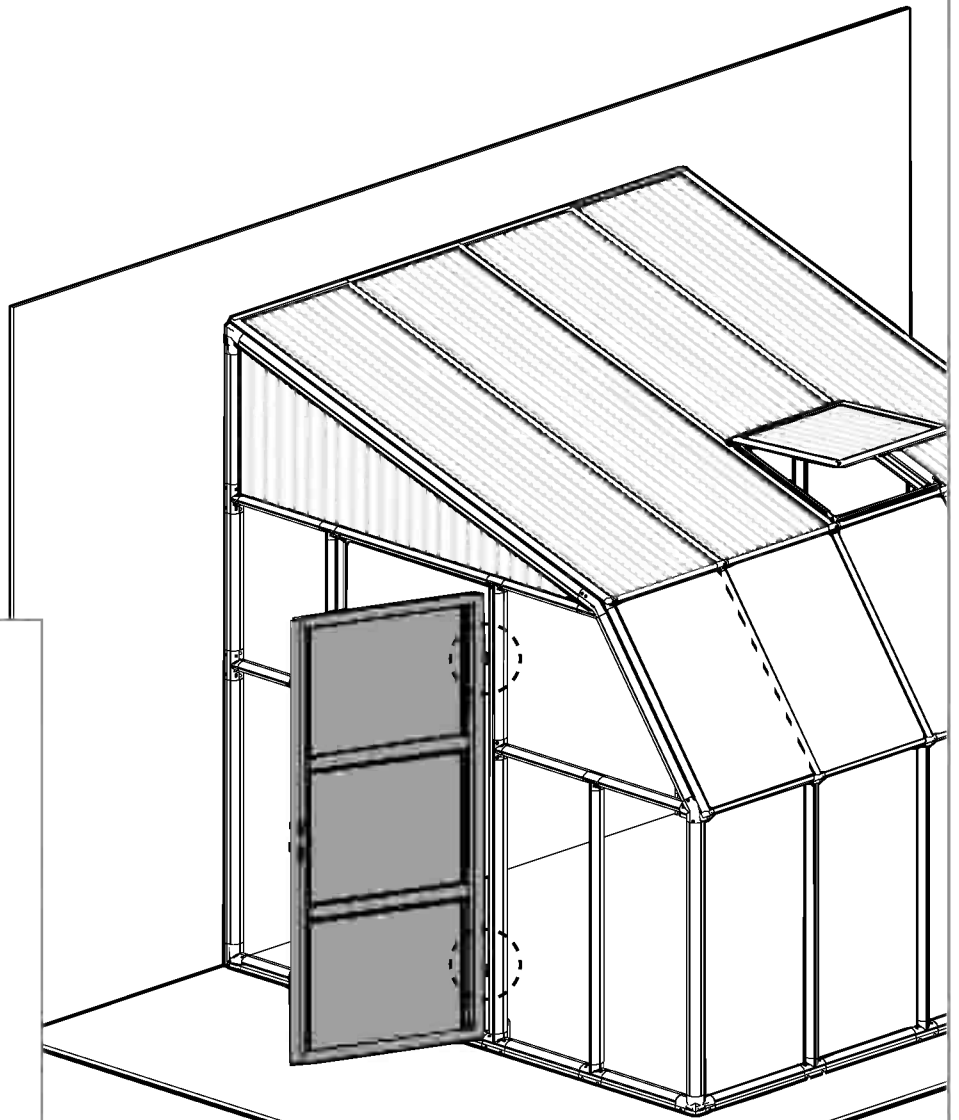
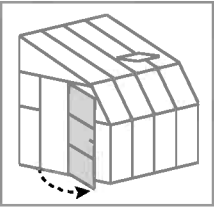
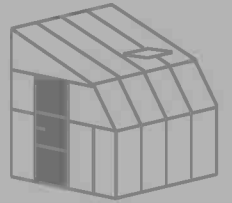
Item		Qty.
DSN		1

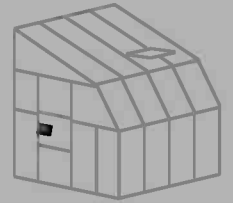

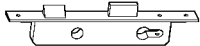

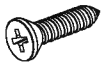

Item		Qty.
7912		1
8039		2
7913		1
7958		1
4043		2

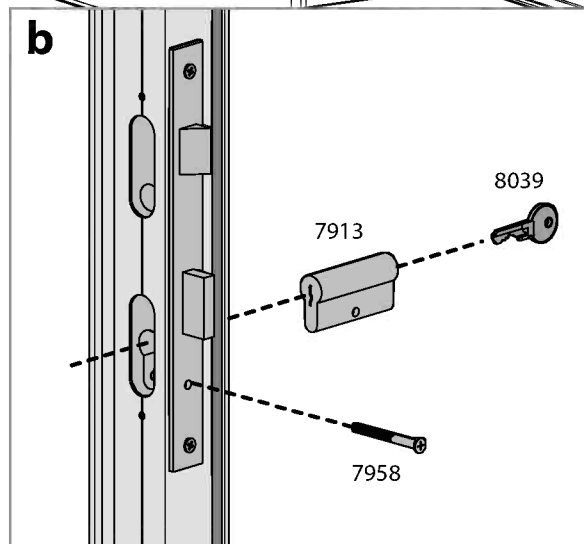
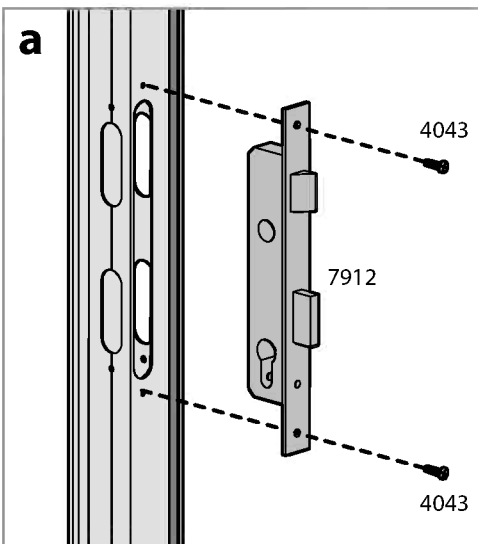
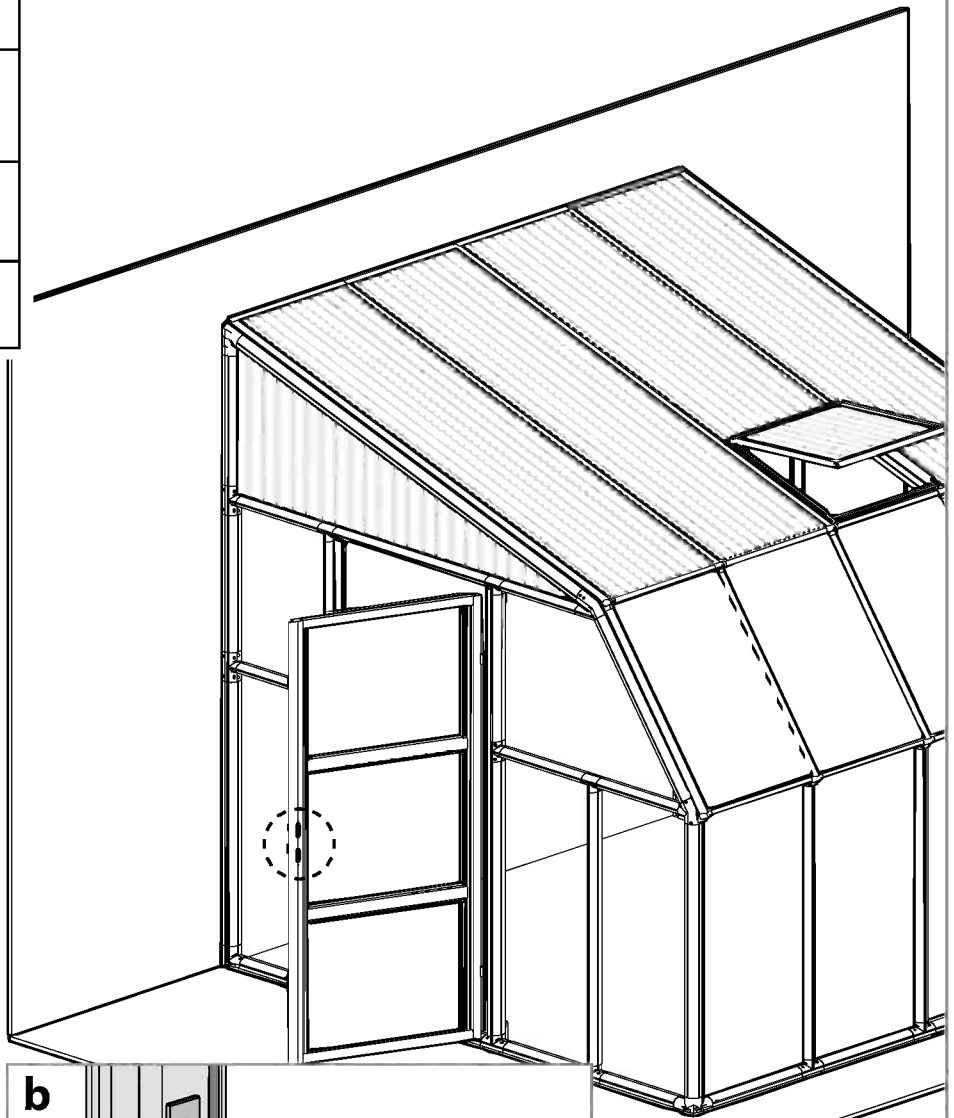
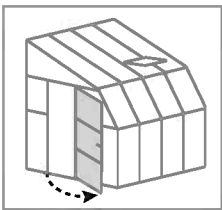

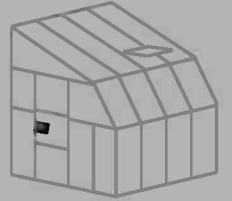

Item		Qty.
7948		2
7994		1
7995		1
7996		2
7442		4

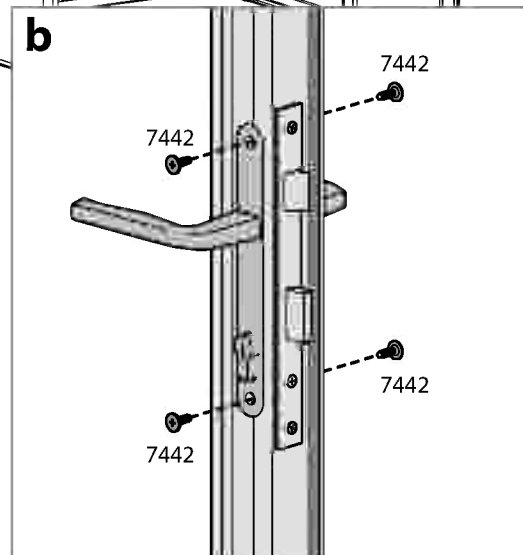
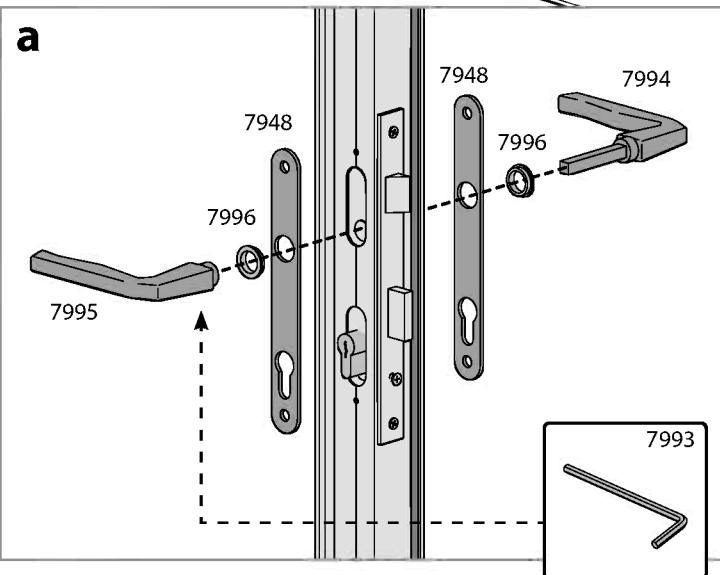
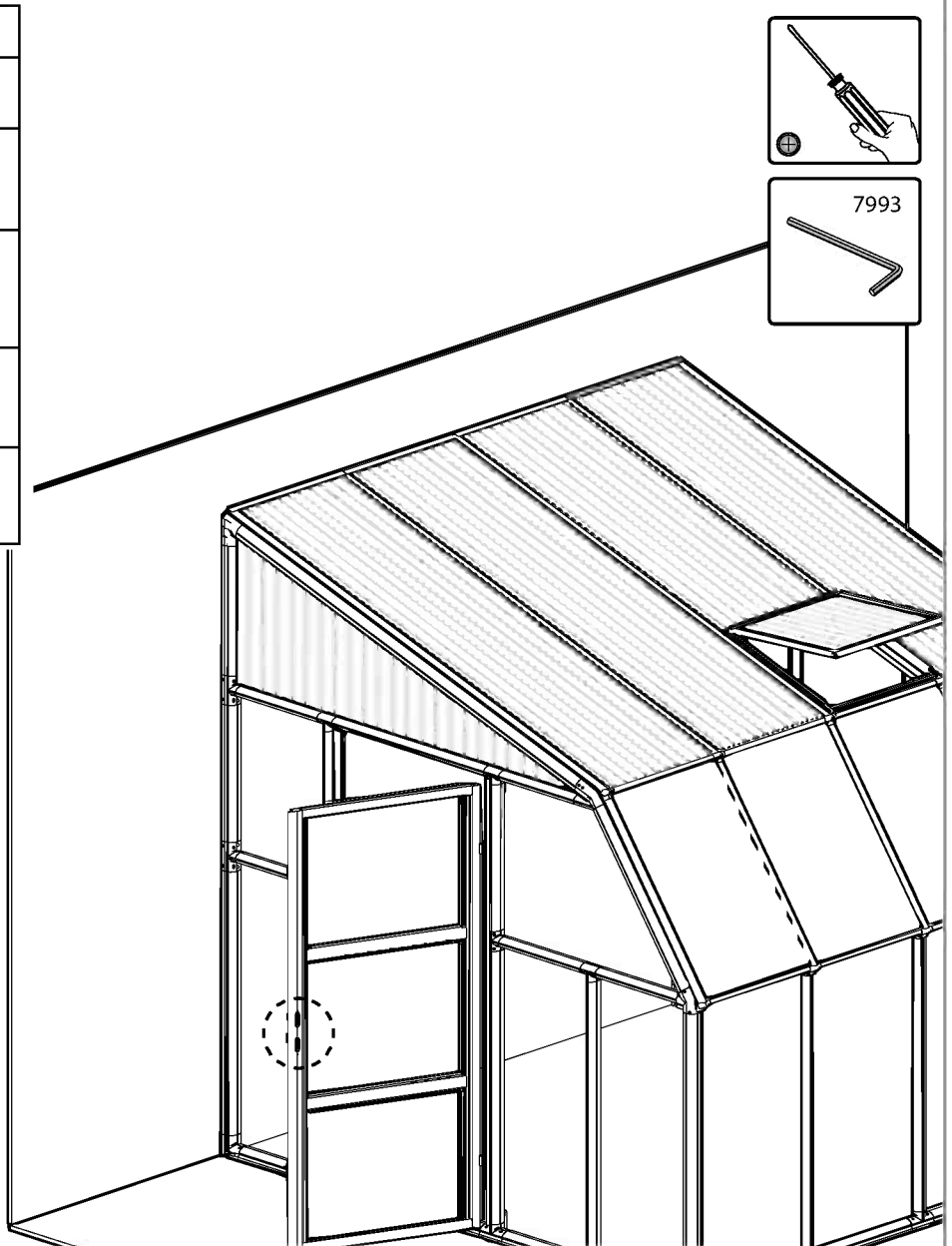
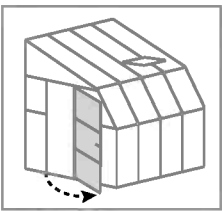
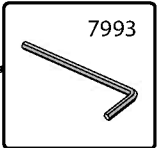
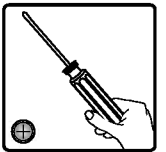

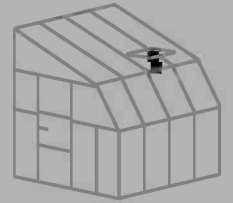



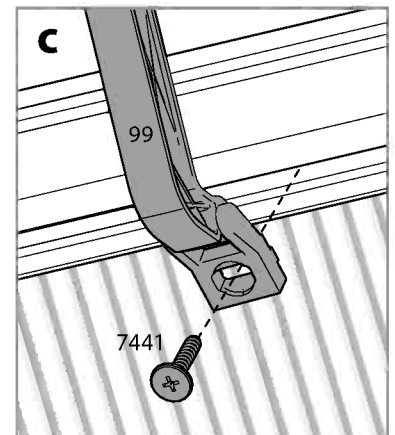
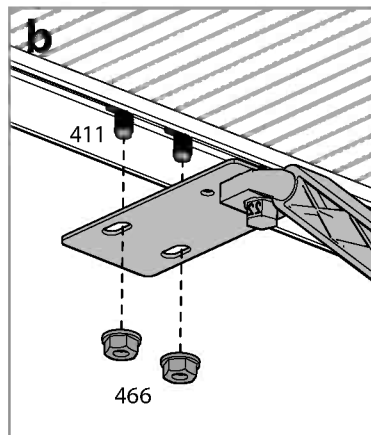
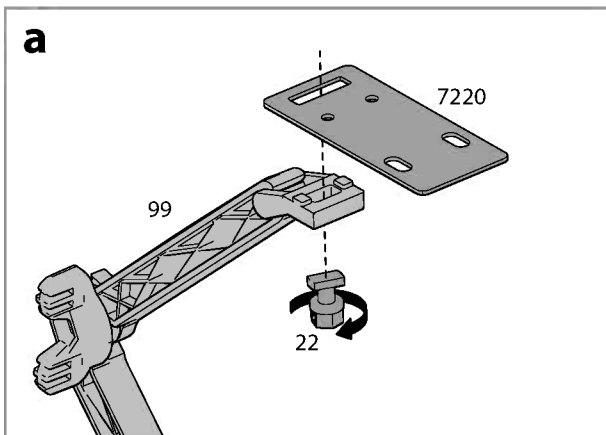
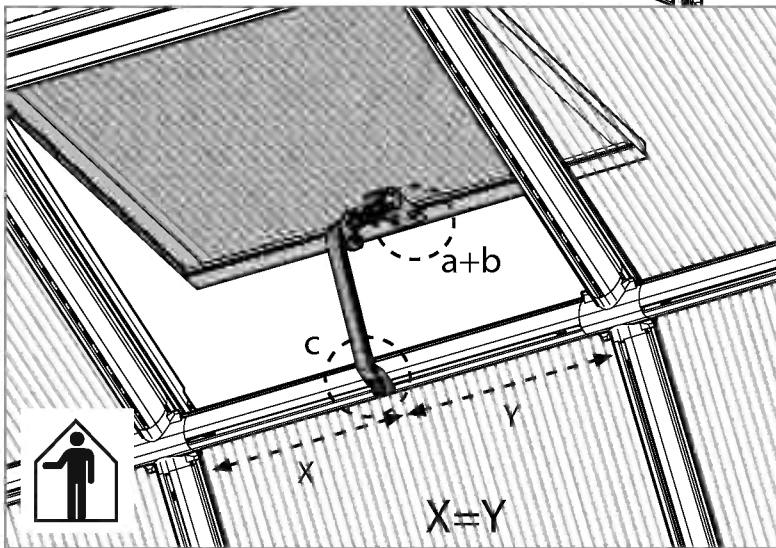
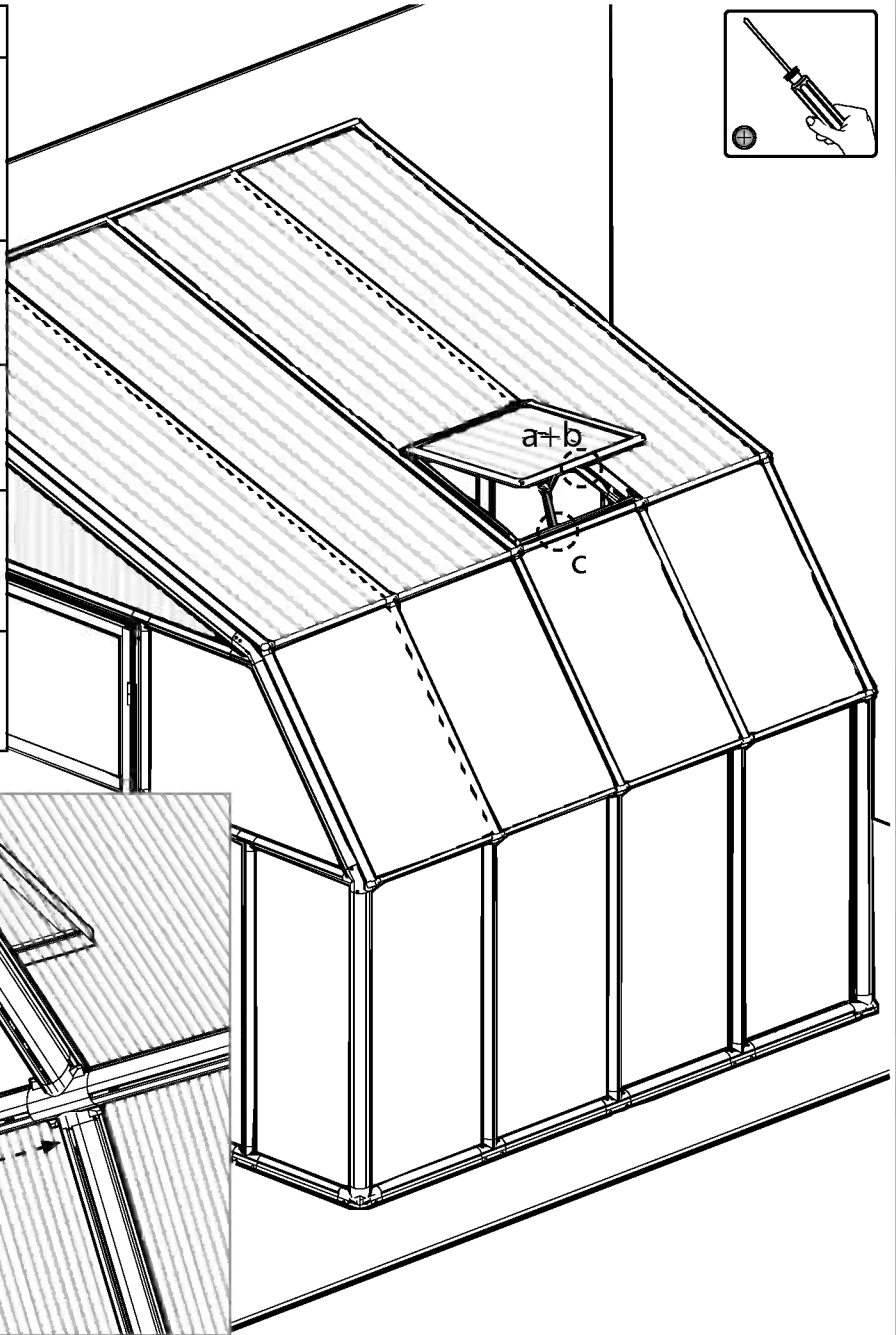

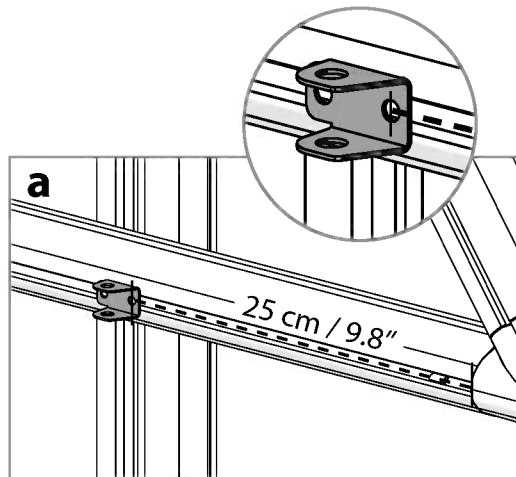
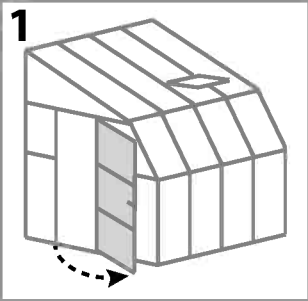
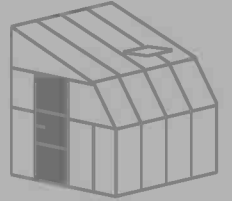
Item		Qty.
99		1
22		1
7441		1
7220		1
466		2

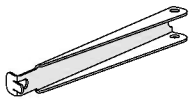

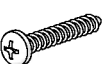

Item		Qty.
8280		1
8279		1
7284		1
7279		1
450		2

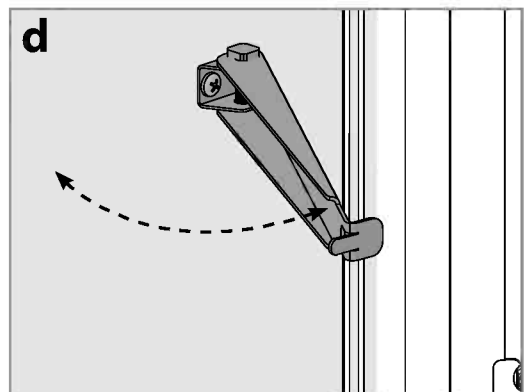
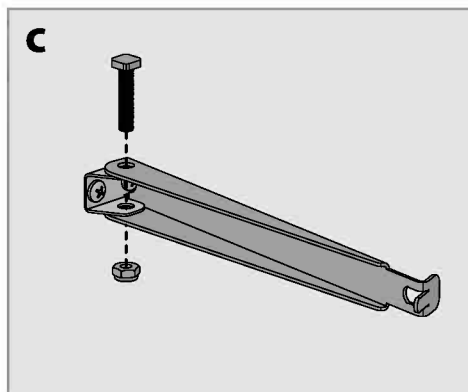
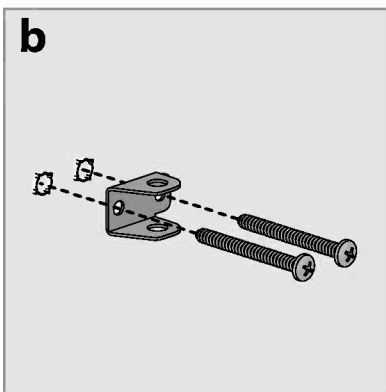
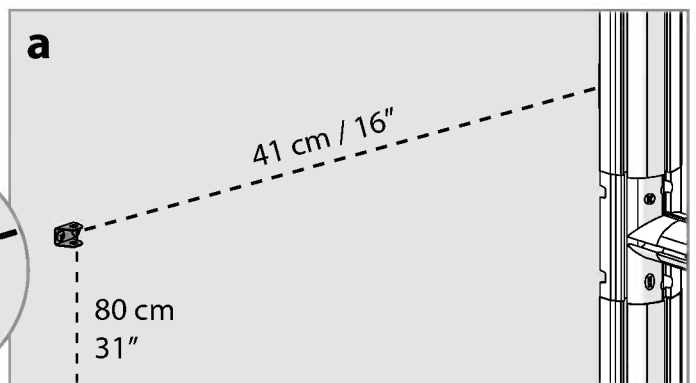
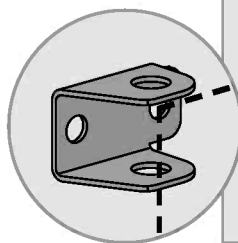
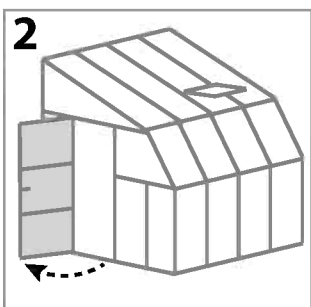
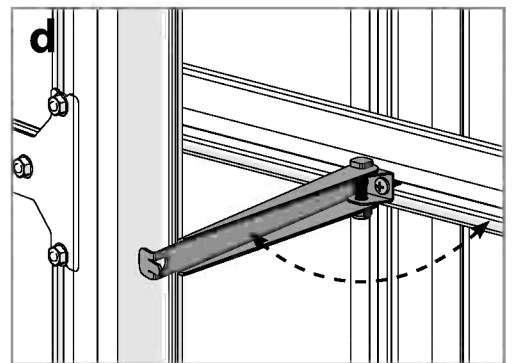
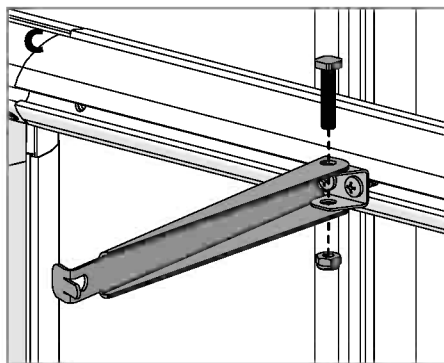
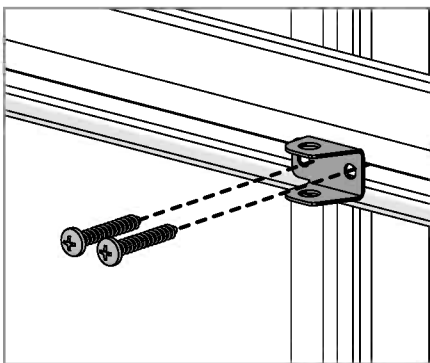

Paltram's 7 years Limited Warranty

Product Details: RION Greenhouses

Paltram Applications (1995) Ltd (Company number: 512106824) whose registered office is at Teradion Industrial Park, M.P. Misgav 20174, Israel ("Paltram") warrants that the Product will be free from defects in material or workmanship for a period of Seven years from the original date of purchase subject to the definitions, terms and conditions contained in this warranty.

- 1. Conditions**
 - 1.1 This warranty shall be valid only if the Product is installed, cleaned, handled and maintained in accordance with Paltram's written recommendations.
 - 1.2 This warranty does not cover: (1) discoloration caused by use of chemicals and/or any other reason other than exposure to Sunlight; (2) damages due to climates not within the temperature exceeds 50° (fifty degrees Fahrenheit); (3) damages due to load exceeding 75 kg / 165 Lb per 1 Sq. Mtr. / 17 Sq. Ft; (4) damages due to exposure to wind speed exceeding 90 Km/HR (55 Miles/HR);
 - 1.3 Without derogating from the above, damage caused by use of force, incorrect handling, inappropriate use, neglectful use or assembly or maintenance accidents, impact from foreign objects, vandalism, pollutants, alteration, painting, connecting, gluing, sealing not in accordance with the user's manual, or damage resulting from cleaning with incompatible detergents and minor deviations of the Product are not covered by this warranty.
 - 1.4 This warranty does not apply to damage resulting from 'force majeure' which includes but is not limited to, hail, storm, tornado, hurricane, blizzard, flood, fire effects.
 - 1.5 This warranty is void if structural parts and components used are not compatible with Paltram's written recommendations.
 - 1.6 This warranty applies only to the original purchaser of the Product. It does not extend to any other purchaser or user of the Product (including, but not limited to, any person who acquires the Product from the original purchaser).

2. Claims and Notifications

- 2.1 Every warranty claim must be notified in writing to Paltram within 30 days after the discovery of the defective Product, enclosing the original sales receipt and this warranty.
- 2.2 The claimant must allow Paltram to inspect the Product involved and the installation site itself while the Product is still in its original position and has not been removed or moved or altered in any way and/or return the Product to Paltram for testing.
- 2.3 Paltram reserves the right to investigate independently the cause of any failure.

3. Compensation

- 3.1 If a claim under this Warranty is properly notified and approved by Paltram, the purchaser, at Paltram's option, may either (a) purchase a replacement Product or parts; or (b) receive refund of the original Product or parts purchase price, all in accordance with the following schedule:

Period After Purchasing	Replacement Product or Parts	Refund
From date of purchase up to end of 1 st year	Free of charge	100%
End of 1 st Year up to end of 2 nd year	purchaser will pay 15% of the original purchase price	85%
End of 2 nd year up to end of 3 rd year	purchaser will pay 30% of the original purchase price	70%
End of 3 rd year up to end of 4 th year	purchaser will pay 45% of the original purchase price	55%
End of 4 th year up to end of 5 th year	purchaser will pay 60% of the original purchase price	40%
End of 5 th year up to end of 6 th year	purchaser will pay 75% of the original purchase price	25%
End of 6 th year up to end of 7 th year	purchaser will pay 85% of the original purchase price	15%

- 3.2 For avoidance of any doubt, calculation for determination regarding compensation for defective parts, according to the schedule above, will be based on the contribution of the defective part to the original cost of the Product. Paltram reserves the right to provide substitutions if the Product or any part of it is unavailable or obsolete.
- 3.3 This warranty does not cover any costs and expenses of removal and installation of the Product or taxes or shipping cost or any other direct or indirect (osses) which may result from the Product failure.

4. General Conditions and Limitations

- 4.1 OTHER THAN HAS BEEN SPECIFICALLY STATED IN THIS WARRANTY, ALL OTHER WARRANTIES, WHETHER EXPRESS OR IMPLIED, INCLUDING ALL IMPLIED WARRANTIES OF MERCHANTABILITY OR FITNESS FOR A PARTICULAR PURPOSE ARE EXCLUDED SO FAR AS THE LAW PERMITS. EXCEPT WHERE WE HAVE SPECIFICALLY STATED IN THIS WARRANTY, PALTRAM SHALL NOT BE LIABLE FOR ANY LOSSES OR DAMAGES THE PURCHASER SUFFERS DIRECTLY, INDIRECTLY OR AS A CONSEQUENCE OF USING OR IN ANY OTHER MANNER CONNECTED TO THE PRODUCT.
- 4.2 IF PALTRAM IS PROHIBITED UNDER ANY APPLICABLE LAW FROM EXCLUDING THE IMPLIED WARRANTIES OF MERCHANTABILITY OR FITNESS FOR A PARTICULAR PURPOSE IN RELATION TO THE PRODUCT, THE DURATION OF ALL SUCH IMPLIED WARRANTIES IS EXPRESSLY LIMITED TO THE DURATION OF THIS WARRANTY OR, IF LONGER, THE MAXIMUM PERIOD REQUIRED BY APPLICABLE LAW.
- 4.3 THE PURCHASER IS SOLELY RESPONSIBLE FOR DETERMINING WHETHER THE HANDLING, STORAGE, ASSEMBLY, INSTALLATION OR USE OF THE PRODUCT IS SAFE AND APPROPRIATE IN ANY LOCATION, FOR ANY GIVEN APPLICATION OR IN ANY GIVEN CIRCUMSTANCE. PALTRAM ARE NOT RESPONSIBLE FOR ANY DAMAGES OR INJURY TO THE PURCHASER, ANY OTHER PERSON OR ANY PROPERTY RESULTING FROM THE IMPROPER HANDLING, STORAGE, INSTALLATION, ASSEMBLY OR USE OF THE PRODUCT OR THE FAILURE TO FOLLOW THE WRITTEN INSTRUCTIONS REGARDING THE HANDLING, STORAGE, INSTALLATION, ASSEMBLY AND USE OF THE PRODUCT.
- 4.4 UNLESS OTHERWISE EXPRESSLY INDICATED BY PALTRAM, THE PRODUCT IS INTENDED FOR NORMAL RESIDENTIAL USE ONLY. PALTRAM ARE NOT RESPONSIBLE FOR ANY LOSS, DAMAGE, COST OR EXPENSE RESULTING FROM ANY USE OF THE PRODUCT FOR ANY PURPOSE THAT IS NOT RECOMMENDED BY THE WRITTEN INSTRUCTIONS OR THAT IS NOT PERMITTED BY ANY APPLICABLE LEGISLATION OR OTHER CODES IN EFFECT IN THE LOCATION WHERE THE PURCHASER WILL USE THE PRODUCT.

EN

7 Jahre beschränkte Garantie von Paltram

Angaben zum Produkt: RION Gewächshäuser

Paltram Applications (1995) Ltd (Firmennummer: 512106824) mit Sitz in Teradion Industrial Park, M.P. Misgav 20174, Israel ("Paltram") garantiert, dass das Produkt für einen Zeitraum von sieben Jahren ab dem Kaufdatum frei von Mängeln in Material und Verarbeitung wird, und den Definitionen, Begriffen und Bedingungen die in dieser Garantie enthalten sind unterliegt.

- 1. Bedingungen**
 - 1.1 Diese Garantie ist nur gültig, wenn das Produkt in Übereinstimmung mit den schriftlichen Empfehlungen von Paltram installiert, gereinigt, behandelt und gepflegt ist.
 - 1.2 Diese Garantie gilt nicht bei: (1) Verfärbungen durch die Verwendung von Chemikalien und/oder aus anderen Gründen, die nicht durch Sonnenlicht entstanden sind; (2) Beschädigungen aufgrund klimatischer Bedingungen mit Temperaturen über 50° (fünfzig Grad) Celsius (122° Fahrenheit); (3) Beschädigungen durch eine Beladung mit mehr als 75 kg/165 Lb pro Quadratmeter/17 Quadratfuß; (4) Beschädigungen durch eine Beladung mit Windgeschwindigkeiten von über 90 km/h/ 55 Meilen pro Stunde.
 - 1.3 Ohne Abweichung von oben genannten, Schäden, die durch Anwendung von Gewalt, unsachgemäße Behandlung, unsachgemäße Verwendung, nachlässige Nutzung, Montage oder Wartung, Unfälle, Auswirkungen von Fremdkörpern, Vandalismus, Verschmutzung, Veränderung, Malerei, Verbinden, Kleben und Dichten, nicht in Übereinstimmung mit der Bedienungsanleitung, verursacht werden, oder Schäden, die bei Reinigung mit inkompatiblen Reinigungsmitteln entstehen, so wie geringfügige Abweichungen des Produkts, werden durch diese Garantie nicht abgedeckt.
 - 1.4 Diese Garantie gilt nicht für Schäden, die durch höhere Gewalt verursacht werden (berührend aber nicht beschränkt auf: Hagel, Sturm, Tornado, Hurrikan, Schneesturm, Überschwemmungen, Feuer Auswüchungen).
 - 1.5 Diese Garantie erlischt, falls Bauteile und Komponente, die nicht mit den schriftlichen Empfehlungen von Paltram kompatibel sind, verwendet werden.
 - 1.6 Diese Garantie gilt ausschließlich für den ursprünglichen Käufer des Produkts. Sie erweitert sich nicht auf keine anderen Käufer oder Benutzer des Produkts (einschließlich, aber nicht beschränkt auf irgendeine andere Person die das Produkt von den ursprünglichen Käufer erwirbt).

2. Ansprüche und Mittelungen

- 2.1 Jeder Gewährleistungsanspruch muss Paltram innerhalb von 30 Tagen nach Entdeckung des fehlerhaften Produkts schriftlich vorgelegt werden. Hierzu reichen Sie bitte auch den Originalkaufbeleg und diese Garantie mit ein.
- 2.2 Der Antragsteller muss Paltram erlauben den betroffenen Produkt und den Aufstellungsort selbst zu überprüfen, während das Produkt noch in seiner ursprünglichen Position ist und nicht entfernt oder verschoben oder in irgendeiner Weise verändert wurde, und/oder den Produkt an Paltram zum Testen zu senden.
- 2.3 Paltram behält sich das Recht vor die Fehlerursachen unabhängig zu untersuchen.

3. Entschädigung

- 3.1 Ist ein Anspruch gemäß dieser Garantie ordnungsgemäß angemeldet und bei Paltram genehmigt worden, kann der Käufer, nach heigem Ermessen von Paltram, entweder (a) ein Ersatzprodukt oder Teile erwerben; oder (b) eine Erstattung des ursprünglichen Produkt oder Teile Kaufpreises erhalten, alles in Übereinstimmung mit dem folgenden Schema:

Zeitraum nach Erwerbung	Ersatzprodukt bzw. Ersatzteile	Rückerstattung
Ab Kaufdatum bis zum Ende des 1. Jahr	Kostenlos	100%
Ende des 1. Jahr bis zum Ende des 2. Jahr	Käufer zahlt 15% des ursprünglichen Kaufpreises	85%
Ende des 2. Jahr bis zum Ende des 3. Jahr	Käufer zahlt 30% des ursprünglichen Kaufpreises	70%
Ende des 3. Jahr bis zum Ende des 4. Jahr	Käufer zahlt 45% des ursprünglichen Kaufpreises	55%
Ende des 4. Jahr bis zum Ende des 5. Jahr	Käufer zahlt 60% des ursprünglichen Kaufpreises	40%
Ende des 5. Jahr bis zum Ende des 6. Jahr	Käufer zahlt 75% des ursprünglichen Kaufpreises	25%
Ende des 6. Jahr bis zum Ende des 7. Jahr	Käufer zahlt 85% des ursprünglichen Kaufpreises	15%

- 3.2 Um jegliche Zweifel aususchließen, wird sich die Berechnung für die Bestimmung über Entschädigungen für defekte Teile, entsprechend der obigen Schema, auf dem Betrag des defekten Teils an den ursprünglichen Kosten des Produktes beziehen. Paltram behält sich das Recht vor für ein Ersatz zu sorgen, falls der Produkt oder ein Teil davon nicht verfügbar oder veraltet ist.
- 3.3 Diese Garantie erstreckt sich nicht auf Kosten und Ausgaben für Aus- und Einbau des Produkts oder Steuern oder Versandkosten oder sonstige direkte oder indirekte Verluste die sich von einem Produktfehler ergeben können.

4. Allgemeine Bedingungen und Einschränkungen

- 4.1 ANDERS ALS BESONDERS IN DIESER GARANTIE ANGEZEIGT, OB AUSDRÜCKLICH ODER IMPLIZIT, EINSCHLIESSLICH ALLE ERHEBLSCHEN LOSSEN GARANTIEBESTANDTEILE DER MARKTGÄNGIGKEIT ODER EIGNUNG FÜR EINEN BESTIMMTEN ZWECK SIND SO WEIT DIES RECHTLICH MÖGLICH IST AUSGESCHLOSSEN.
- 4.2 AUSSER ALS AUSDRÜCKLICH IN DIESER GARANTIE ANGEZEIGT, HÄFTET PALTRAM NICHT FÜR IRGENDWELCHE VERLUSTE ODER SCHÄDEN, DIE DER KÄUFER, DIREKT ODER INDIREKT ODER ALS FOLGE DER NUTZUNG ODER IN IRGENDWELCHEN ANDEREN MIT DEM PRODUKT VERBUNDENEN WEISE LEIDET. FALLS PALTRAM EIN AUSSCHLUSS DER STILLSCHWEBENDEN GARANTIEEN DER MARKTGÄNGIGKEIT ODER EIGNUNG FÜR EINEN BESTIMMTEN ZWECK IN BEZUG AUF DAS PRODUKT NACH GELTENDEM RECHT NICHT GESTATET IST, WIRD DIE DAUER ALLER SOLCHEN GARANTIEEN AUSDRÜCKLICH AUF DIE DAUER DIESER GARANTIE BESCHRÄNK, ODER FALLS LÄNGER, AUF DIE GEFETZLICH VORGESCHRIEBENE HOCHSTAUER.
- 4.3 DER KÄUFER IST ALLEIN DARFÜR VERANTWORTLICH FESTZUSTELLEN, OB DIE HANDHABUNG, LAGERUNG, MONTAGE ODER NUTZUNG DES PRODUKTS ODER DURCH VERWENDUNG DES PRODUKTS AN BELIEBIGEN STANDORT UND FÜR JEDE GEBEBENE ANWENDUNG ODER SITUATION, SICHER UND ANGEMESSEN IST. PALTRAM IST NICHT VERANTWORTLICH FÜR SCHÄDEN ODER VERLETZUNGEN DES KÄUFERS, ANDERER PERSONEN ODER DES EIGENTUMS, DIE IN FOLGE EINER UNSACHGEMÄSSEN HANDHABUNG, LAGERUNG, EINBAU, MONTAGE ODER NUTZUNG DES PRODUKTS ODER DURCH NICHTBEACHTUNG DER ANWEISUNGEN ZUR HANDHABUNG, LAGERUNG, EINBAU, MONTAGE UND NUTZUNG DES PRODUKTS ENTSTANDEN SIND, SOWEIT NICHT AUSDRÜCKLICH ANDERS BY PALTRAM ANGEZEIGT. IST DAS PRODUKT FÜR NORMALE WOHNUNGSNUTZUNG BESTIMMT, PALTRAM HÄFTET NICHT FÜR VERLUSTE, SCHÄDEN, KOSTEN ODER AUSGABEN, DIE AUS EINER NICHT VON DEN ANWEISUNGEN EMPFOHLENE VERWENDUNG DES PRODUKTS ZU IRGENDNEM ZWECK ENTSTEHEN ODER DIE VON KEINEM GELTENDEN RECHTSVORSCHRIFTEN ODER ANDEREN CODES ERCLAUBT SIND, DIE AN DEM ORT, WO DER KÄUFER DEN PRODUKT BENUTZEN WIRD, IN KRAFT SIND.

DE

Garantie limitée à 7 ans de Palram

Détails du produit: Serres RION

Palram Applications (1995) Ltd (Compagnie nr 512106824) dont le siège social est adressé au Parc Industriel Teradion, M.P. Milsqav 20174, Israël ("Palram"), garantit que le Produit n'a aucun défaut de matériel ou de manufacture pour une période de sept ans à dater de la date d'acquisition, conformément aux définitions et conditions incluses dans cette garantie.

1. Conditions

Cette garantie ne sera valide que si le Produit est installé, nettoyé, manipulé et entreteu conformément aux recommandations écrites de Palram. Cette garantie ne couvre pas : (1) la décoloration causée par l'utilisation de produits chimiques et/ou pour tout autre motif autre que l'exposition à la lumière du soleil; (2) les dommages dus aux climats où à une température dépassant les 50 °C (cinquante degrés) Celsius (122 ° degrés Fahrenheit); (3) les dommages dus à une charge supérieure à 75 kg/165 lb pour 1 m²/17 Sq. Ft.; (4) les dommages à la suite d'une exposition au vent dépassant les 90 km/h (55 miles/h).

Sans dérogé de ce qui est susdit, tout dommage causé par usage de la force, une mauvaise manipulation, un usage inapproprié, une utilisation, un montage ou une maintenance négligente, des accidents, un impact avec d'autres objets étrangers, du vandalisme, des polluants, un dégat, une peinture, connexion, collage, scellage qui n'est pas conforme avec le manuel de l'utilisateur ou tout dommage résultant de son nettoyage avec un détergent incompatible et les moindres déviations du Produit ne sont pas couverts par cette garantie. Cette garantie ne s'applique pas aux dommages résultant d'un acte de force majeure, qui comprend mais n'est pas limité par la grêle, la tempête, une tonnée, un ouragan, un blizzard, une inondation ou les effets d'un incendie.

Cette garantie est nulle si des parties de la structure et des composants ne sont pas comparables aux recommandations écrites par Palram. Cette garantie ne s'applique qu'à l'acheteur d'origine du Produit. Elle ne s'étend pas à tout autre acquéreur ou utilisateur du Produit (y compris mais non limité à toute personne qui acquiert le Produit de son acquéreur d'origine).

2. Réclamations et notifications

Toute demande de garantie doit être notifiée par écrit à Palram dans les 30 jours suite à la découverte du produit défectueux, accompagnée du ticket de caisse original et de cette garantie.

Le demandeur doit permettre à Palram d'inspecter le Produit impliqué et le site d'installation lorsque le Produit est dans son emplacement d'origine et n'a pas été enlevé ou déplacé ni modifié de quelque façon et/ou envoyer le Produit à Palram pour vérification.

Palram se réserve le droit de quêquer indépendamment sur la cause de toute panne.

3. Compensation

Si une réclamation sous cette garantie est convenablement notifiée et approuvée par Palram, l'acheteur, au choix de Palram, peut soit (a) acquérir un Produit de remplacement ou des pièces; ou (b) recevoir un remboursement du prix d'achat du Produit d'origine ou d'une partie, tout cela conformément à la table suivante:

Période depuis l'achat	Produit de remplacement ou partie	Remboursement
Jusqu'à un an après l'achat	Gratuit	100%
De la fin de la 1 ^{ère} année à la fin de la 2 ^{ème}	L'acquéreur paiera 15% du prix d'achat d'origine	85%
De la fin de la 2 ^{ème} année à la fin de la 3 ^{ème}	L'acquéreur paiera 30% du prix d'achat d'origin	70%
De la fin de la 3 ^{ème} année à la fin de la 4 ^{ème}	L'acquéreur paiera 45% du prix d'achat d'origine	55%
De la fin de la 4 ^{ème} année à la fin de la 5 ^{ème}	L'acquéreur paiera 60% du prix d'achat d'origine	40%
De la fin de la 5 ^{ème} année à la fin de la 6 ^{ème}	L'acquéreur paiera 75% du prix d'achat d'origine	25%
De la fin de la 6 ^{ème} année à la fin de la 7 ^{ème}	L'acquéreur paiera 85% du prix d'achat d'origine	15%

3.2 Pour éviter le moindre doute, le calcul pour déterminer la compensation pour des pièces défectueuses, selon la table ci-dessus, sera basé sur la contribution de la pièce défectueuse au coût d'origine du Produit. Palram se réserve le droit de fournir des substitutions si le Produit ou une partie de celui-ci n'est plus disponible ou est obsolète.

3.3 Cette garantie ne couvre pas les coûts et les dépenses de déplacement et d'installation du Produit ou les taxes et frais de port ou toute autre perte directe ou indirecte qui pourrait résulter de la panne du Produit.

4. Conditions générales et limitations

MIS À PART CE QUI A ETE SPECIFIQUEMENT INDIQUE DANS CETTE GARANTIE, TOUTES LES AUTRES GARANTIES, EXPRESSES OU SOUS-ENTENDUES Y COMPRIS TOUTES LES GARANTIES SOUS-ENTENDUES DE VALEUR MARCHANDE OU PARDAPABILITE POUR UN OBJECTIF PARTICULIER SONT EXCLUES POUR AUTANT QUE LA LOI LE PERMET.

4.1 MIS À PART LA OU NOS TAONS SPECIFIQUEMENT DECLARE DANS CETTE GARANTIE, PALRAM N'EST PAS RESPONSABLE DE TOUTE PERTE OU DOMMAGE DONT L'ACQUEUREUR SOUFFRIRAIT, DIRECTEMENT, INDIRECTEMENT OU EN CONSÉQUENCE DE L'UTILISATION DU PRODUIT OU DE TOUTE AUTRE MANIÈRE LIBRE AU PRODUIT.

4.2 SI PALRAM N'A PAS LE DROIT SELON LA MOINDRE LOI APPLICABLE D'EXCLURE LES GARANTIES SOUS-ENTENDUES DE VALEUR MARCHANDE OU D'ADAPABILITE À UNE FIN SPECIFIQUE EN RAPORT AVEC LE PRODUIT, LA DUREE D'UNE TELLE GARANTIE EST EXPRESSEMENT LIMITEE A CELLE DE CETTE GARANTIE OU, SI ELLE EST PLUS LONGUE, À LA PERIODE MAXIMALE EXGEE PAR LA LOI.

4.4 L'ACHETEUR EST LE SEUL RESPONSABLE DANS LA DETERMINATION SI LA MANIPULATION, LE STOCKAGE, LE MONTAGE, L'INSTALLATION OU L'UTILISATION DU PRODUIT EST SURE ET APPROPRIEE POUR TOUT ENDROIT, POUR TOUTE APPLICATION DONNEE OU DANS TOUTE CIRCONSTANCE DONNEE. PALRAM N'EST PAS RESPONSABLE DE TOUT DOMMAGE OU BLESSURE CAUSE A L'ACHETEUR, TOUTE AUTRE PERSONNE OU BIEN RESULTANT D'UNE MANIPULATION, UN STOCKAGE, UNE INSTALLATION, UN MONTAGE OU UNE UTILISATION DU PRODUIT OU UN MANQUE A SUIVRE LES INSTRUCTIONS ECrites CONCERNANT LA MANIPULATION, LE STOCKAGE, LE MONTAGE, L'INSTALLATION OU L'UTILISATION DU PRODUIT.

4.5 SAUF S'IL INDIQUE EXPRESSEMENT PAR PALRAM, LE PRODUIT EST DESTINE A UN USAGE RESIDENTIEL NORMAL. SEULEMENT PALRAM N'EST PAS RESPONSABLE DE TOUTE PERTE, DOMMAGE, FRAIS OU DEPENSE RESULTANT D'UNE UTILISATION DU PRODUIT POUR TOUTE FIN QUI N'EST PAS RECOMMANDEE PAR LES INSTRUCTIONS ECrites. OU QUI N'EST PAS PERMISE PAR LA MOINDRE LOI OU AUTRES CODES APPLICABLES DANS L'ENDROIT OU L'ACQUEUREUR UTILISERAIT LE PRODUIT.

FR

Palrams 7 års Begrænset Garanti

Produkt detaljer: RION Drivhus

Palram Applications (1995) Ltd. (Virksomhedsregistreringsnummer: 512106824), registreret på adressen Teradion Industrial Park, M.P. Milsqav 20174, Israel ("Palram"), garanterer at Produktet ikke lider af materiefejl eller fabriksationsfejl i en periode på syv år fra købsdatoen, underlagt definitionerne og vilkårene indeholdt i denne garanti.

1. Vilkår

1.1 Denne garanti er kun gældende, hvis Produktet er installeret, rengjort, håndteret og vedligeholdt i overensstemmelse med Palrams skrevne anbefalinger. Denne garanti dækker ikke: (1) Misfarvning forårsaget af brugen af kemikalier og/eller enhver anden årsag eksposering til sollys; (2) skader grundet klimater hvor temperaturen overstiger 50° (halvtreds grader) Celsius (122 ° grader Fahrenheit); (3) skader grundet belæsning, der overstiger 75 kg / 165 pund per 1 kvadratmeter / 17 kvadratfod; (4) skader grundet eksposering til vindhastighed, der overstiger 90 km/t/55 miles/t).

1.2 Uden at afvige fra det ovennævnte, er skade opstået grundet brug af fysisk magt, ukorrekt håndtering, upassende brug, forsømmelig brug, samling eller vedligeholdelse, ulykke, indvirkning fra fremmedlegemer, vandslisne, forurenende stoffer, ændringer, maling, tilslutning, limning, forsøgning, der ikke er i overensstemmelse med brugvejledningen, eller skade som resultat af rengøring med ikke-kompatible rengøringsmidler og mindre afvigelser ved produktet, ikke dækker af denne garanti.

1.3 Denne garanti dækker ikke skade som resultat af "naturns handling", hvilket omfatter, men er ikke begrænset til hagl, storm, tornadoer, orkaner, snestorme, oversvømmelse, følger af brand.

1.4 Denne garanti er ugyldig, hvis der benyttes konstruktionsdele og løse dele, der ikke er kompatible med Palrams skrevne anbefalinger.

1.5 Denne garanti er kun gældende for Produkets oprindelige køber. Den omfatter ikke andre købere eller brugere af Produktet (inklusive, men ikke begrænset til, enhver person der erhverver Produktet fra den oprindelige køber).

2. Krav og Bekendtgørelser

2.1 Enhvert garantkrav skal bekendtgøres skriftligt til Palram inden for 30 dage, efter opdagelsen af det defekte Produkt, og vedlægges den originale kvittering og denne garanti.

2.2 Skadestemmelens skal lade Palram undersøge Produktet, der er tale om, og selve installationen, mens Produktet stadig befinder sig i sin oprindelige position og ikke er blevet fjernet eller flyttet eller ændret på nogen måde, og/eller lade produktet sende tilbage til Palram for afprøvning.

2.3 Palram forbeholder sig retten til selvstændigt at undersøge årsagen til dette funktionssvigt.

3. Erstatning

3.1 Hvis et krav i henhold til denne garanti bekendtgøres korrekt og godkendes af Palram, kan køberen, efter Palrams valg, (a) købe et erstatningsprodukt eller dele, eller (b) modtage refundering for det oprindelige Produkts eller delens købspris, alt i henhold til den følgende oversigt:

Periode Efter Køb	Erstatningsprodukt eller Delle	Refundering
Fra købsdato til udgangen af 1. år	Uden beregning	100%
Udgangen af 1. år til udgangen af 2. år	køber vil betale 15 % af den oprindelige købspris	85%
Udgangen af 2. år til udgangen af 3. år	køber vil betale 30 % af den oprindelige købspris	70%
Udgangen af 3. år til udgangen af 4. år	køber vil betale 45 % af den oprindelige købspris	55%
Udgangen af 4. år til udgangen af 5. år	køber vil betale 60 % af den oprindelige købspris	40%
Udgangen af 5. år til udgangen af 6. år	køber vil betale 75 % af den oprindelige købspris	25%
Udgangen af 6. år til udgangen af 7. år	køber vil betale 85 % af den oprindelige købspris	15%

3.2 For at undgå tvivl vil beregning for bestemmelse af erstatning for defekte) dele/, i henhold til oversigten ovenfor, blive baseret på den defekte del's dækning i forhold til Produkets oprindelige pris. Palram forbeholder sig retten til at levere erstatninger, hvis Produktet, eller nogen del af dette, er utilgængeligt eller forladt.

3.3 Denne garanti dækker ikke omkostninger eller udgifter ved fjernelse og installation af Produktet, eller afgifter, eller forsejlsesomkostninger, eller nogen direkte eller indirekte tab, der kan opstå grundet Produktfejl.

4. Almindelige Betingelser og Begrænsinger

4.1 OM UENR HAAD DER ER BLIVET SPECIFIKT ANFØRT I DENNE GARANTI, ER ALLE ANDRE GARANTIER, OM UTRYKT ELLER UNDERFORSTÅET, OMFATTENDE ALLE UNDERFORSTÅEDE GARANTIER VEDRØRENDE SALSGARHED ELLER EGENHED TIL ET SPECIFIKT FORMÅL UINDTAGET FOR SA VIDT LOVEN TILLADDER

4.2 MED UINDTAGELSE AF HVOR VI HAR SPECIFIKT ANFØRT DET DENNE GARANTI, ER PALRAM IKKE ANSVARLIG FOR NOGENTAL ELLER SKADER, SOM KØBEREN UNDER DIRKTE, INDIRKTE, ELLER SOM EN FØLGE AF BRUG, ELLER PÅ NOGEN ANDEN MÅDE FORBINDER SIG TIL, PRODUKTET.

4.3 HVIS PALRAM UDEKLARER FRA, I HENHOLD TIL, ENHVER GÆLDENDE LOV, AT UINDTAGE DEN UNDERFORSTÅEDE SALSGARHEDS ELLER EGENHEDSGARANTI FOR ET SPECIFIKT FORMÅL I FORHOLD TIL PRODUKTET, ER VARIGHEDEN AF ALLE SÅDANNE UNDERFORSTÅEDE GARANTIER UTRYKKELG BGRÆNSET TIL VARIGHEDEN AF DENNE GARANTI, ELLER, HVIS LÆNGERE, DEN MAKSIMALE PERIODE KRÆVET AF GÆLDENDE LOVGIVNING.

4.4 KØBEREN ER ENFANSVARLIG FOR AT BESLUTTE OM HÅNDTERINGEN, OPEBVARINGEN, SAMLINGEN, INSTALLATIONEN ELLER BRUGEN AF PRODUKTET ER SIKERT OG PASSESND PÅ ETHVERT OMRÅDE, TIL, ENHVER APPLIKATION ELLER UNDER ETHVERT GIVNET FORHOLD. PALRAM ER IKKE ANSVARLIG FOR NOGEN SKADER ELLER KVEST ELLER KØBER, ENHVER ANDEN PERSON, ELLER ENDOM MATTE LIDE, SOM RESULTAT AF UBEREKT HÅNDTERING, OPEBVARING, INSTLLATION, SAMLING ELLER BRUG AF PRODUKTET ELLER UUDLADSE AF AT FØLGE DE SKREVNE ANBEFALINGER VEDRØRENDE HÅNDTERING, OPEBVARING, INSTLLATION, SAMLING OG BRUG AF PRODUKTET.

4.5 MEDMINDRE ANDET ER UTRYKKELG ANGISET AF PALRAM, ER PRODUKTET KUN BEREGET TIL ALMINDELIG BOUTGFORMÅL. PALRAM ER IKKE ANSVARLIG FOR TAB, SKADE, OMKOSTNINGER ELLER UDGFITER SOM RESULTAT AF NOGEN BRUG AF PRODUKTET TIL NOGET, DER IKKE ER ANBEFALLET I DE SKREVNE ANBEFALINGER, ELLER IKKE ER TILLADT I HENHOLD TIL, NOGEN GÆLDENDE LOVGIVNING ELLER ANDRE GÆLDENDE REGLER PÅ DET STED, HVOR KØBER VIL BRUGE PRODUKTET.

DA

Palram 'n 7 vuoden rajoitetut takuuehdot

Tuotetiedot: RION Kasvihuoneet

Palram Applications (1995) Ltd (yhtiön rek:nro 512106824) jonka päätoimipaikka on osoitteessa Teradion Industrial Park, M.P. Misgav 20174, Israel, Palram taakehti, että se valmistamissa tuotteissa ei sisälly virheitä materiaali- tai valmistusvirhe vuonna seuraavan selksemän vuoden alkuperäisestä ostopäivästä jotta on ilmoitettu takuuehdot.

1. Olosuhteet

- 1.1 Tämä takuu on voimassa vain tuotteelle joka on ohjeen mukaisesti asennettu, hoidettu & ylläpidetty sekä pidetty puhtaan
- 1.2 Palramin ohjekirjassa arztamen ohjeiden mukaisesti
- 1.3 Tämä takuu ei koske: (1) kemikaalien käyttöä järkeä muista syistä paitsi auringon valolle altistumisesta johtuva värin haalistuminen; (2) vahinkoja, jotka johtuvat yli 50 (viisikymmentä) Celsius-asteen lämpöisistä ilmastosta (122° Fahrenheit-astetta); (3) yli 75 kg / 165 lb per 1 m² / 17 F/2 kuormien aiheuttamia vaurioita; (4) yli 90 km/h (55 mailia/h) voimakkaalle tuulelle altistumisesta aiheutunutta vaurioita. Poikkeamatta edellä mainitusta, vaurioita jotka ovat syntyneet liiallisesta voiman käytöstä, väärästä tai sopimattomasta käytöstä, huolimattomasta asennuksesta, käytöstä tai ylläpidosta, vahingoista, ilmastosta, telppäyksistä, sopimattomista tiivistyksistä tai vaurioista jotka ovat syntyneet yhteensopimattomista puhdistusaineista. Pienet poikkeamat eivät kuulu tähän takuun piiriin.
- 1.4 Tämä takuu ei kata luononilmiöitä taikka niistä syntyneitä vaurioita kuten rakeet, raskas lumi, myrsky, pyörremyrsky, hirmumyrsky, salamet, tulit taikka tuiva.
- 1.5 Tämä takuu on mitään mikäli kasvihuoneen kanssa käytetään yhteensopimattomia rakennosisiä taikka komponentteja
- 1.6 Tämä takuu on alhoastaan voimassa alkuperäiselle ostajalle / saajalle. Se ei ole järkevissä tai siirrettävissä toisille käyttäjille taikka seuraaville omistajille.

2. Reklamaatio ja ilmoitukset

- 2.1 Kaikkii takuuvaihtumukseen on tehtävä kirjallisesti Palramille 30 päivän sisällä virheisen tuotteen huomamisesta, ja mukaan on liitettävä alkuperäinen ostokuitti ja tämä takuu.
- 2.2 Kantajan (reklamatorin) tehtävä tulee salla valmistajan / valmistajan edustajan tarkistaa vioittunut tuote sen alkuperäisessä sijainnissa siinä kunnossa kuin se on vaurion sattuessa jälkeen. Tuotetta ei saa munnella, korjata, siirtää taikka lähettää valmistajalle / edustajalle ennen siihen saatua lupaa.
- 2.3 Valmistaja (Palram) varaa oikeuden saada itsenäisesti turkka vian syy.

3. Korvaus

- 3.1 Mikäli reklamaatio on takuun mukaisesti ilmoitettu ja hyväksytty Palramilta, on ostaja (kantaja) oikeutettu joko korvaaviin osiin / tuotteeseen taikka hyvitykseen joka on suhteessa vahinkoon & hankintahintaan seuraavan taulukon mukaisesti:

Alkua hankintamasta	Korvaava tuote ja / tai osa	Korvaus
1 vuosi hankintamasta	veloituksetta	100%
1 => 2' teen vuoteen hankintamasta	Onavastuu 15 %	85%
2 => 3' teen vuoteen hankintamasta	Onavastuu 30 %	70%
3 => 4' teen vuoteen hankintamasta	Onavastuu 45 %	55%
4 => 5' teen vuoteen hankintamasta	Onavastuu 60 %	40%
5 => 6' teen vuoteen hankintamasta	Onavastuu 75 %	25%
6 => 7' teen vuoteen hankintamasta	Onavastuu 85 %	15%

- 3.2 Valtiytykseen milään epäilyttä, laakentavirheitä tai väärinkäytöksiä korvattavuden syyteen edellä esitetyn taulukon mukainen korvaus laakenta aina välillisen / viottuneen osan osuudesta kokonaisuutteen hankinta arvoista. Valmistaja varaa oikeuden toimittaa korvaava tuote / tuoteosa mikäli alkuperäistä osaa ei ole enää saatavissa tai se on vanhentunut. Tämä takuu ei korvaa kuluja jotka ovat syntyneet asennuksesta, purkuksesta, tuotteen siirtämisestä tai korjauksesta eikä myöskään suorista tai epäsuorista kuluista & menestyksistä kuten vaurioita, muuttoja, toimintus- & lähteyksilyistä jotka ovat syntyneet tuotteen virallisuudesta tai virheellisyydestä.

4. Yleiset ehdot ja rajoitukset

- 4.1 MUUTA OSIN KUIN NIMENOMISESTI TÄKSÄ TAKUUSSA ON ESETTYTTÄ, KAIKKIEN MUIDEN TAKUIDEN YLEISTROUUDET KAUPALLISESTA HYÖDYNNETTÄVYYDESTÄ TA SOPIVUUDESTA SUORAKAN TA VALMILISESTI OVAAT POISSULUTTU SIKALI KUIN LAKI SALLII.
- 4.2 POSIUKIEN MITÄ NÄSKÄ TUOKUHOISSA ON ESETTYTTÄ VALMISTAJA EIVASTAA MISTÄÄN TAPPIOISTA TAI VAHINGOISTA MITÄ OSTAJA TAI TUOTTENEN KÄYTTÄJÄ KÄRSI SUORAKAN, VÄLILISESTI TAI SEURAKUSENA TUOTTENEN KÄYTTÄMISESTÄ TAI YHTYÖDESTÄ TUOTTEESEEN.
- 4.3 MIKÄLI VALMISTAJA ON KIELLETTY EIVÄT PAKKAILLISESTI SOVELLETTAVAN LAINSÄADÄNNÖN TAI KULTTUURISUOLA SUOSTUSTIEN POHJALLA TARKUHEITON MUKAISENA KONAKUISA — SOVELLETTAVAN YLEISESTI KAUPALLISESTI HYÖDYNNETTÄVYYDESTÄ TAI SOPIVUUDESTA TIETTYVN TAKUUKIUSEEN VÄHDEN TUOTTENEN OLEMAN TAKUIDEN VOIMASSA OLOAKKA PAKKAILISEN LAIN MUKAAN.
- 4.4 OSTAJA ON KESIN VASTUUSSA ASIANMUKAISESTA KÄSITTELYSTÄ, VARASTOINNISTA, KOKOONPANOUSTA SEKÄ TURVALLISESTA SIAINNISTÄTTÄ KÄYTOSTÄ JA SÄILLYKSESTÄ. PALRAM EI OLE VASTUUSSA MISTÄÄN VAHINGOISTA TAI VAMMOISTA OSTAJALLE EIVÄLLE HENKILÖLLE TAI OSAPUOLELLE TAI HÄNEN OMAKSUUDELLE EIVÄLLE JOHTUVIA VÄÄRÄSTÄ KÄSITTELYSTÄ, VARASTOINNISTA, ASENNUKSESTA, KOKOAMISESTA TAI TUOTTENEN VÄÄRÄSTÄ KÄYTOSTÄ OHEIDEN NOUTAMATTA TÄTTÄMISESTÄ.
- 4.5 PALRAMIN VALMISTAMIA TUOTE ON TARKOITETTU NORMAALIIN ASUMIIN PIIHÄÄVÄTÖÖN EILEI TOISIIN OLE MERKITTY. PALRAM EI OLE VASTUUSSA MISTÄÄN MENETYKSESTÄ, VAHINGOISTA, KUSTANNUKSISTA TAI KULUISTA JOTKA JOHTUVAT TUOTTENEN VÄÄRÄSTÄ KÄYTOSTA MIHINTÄHÄNSÄ TARKOITUKSEEN, MIKÄLI EI OLLA NOUTADUTTU SUOSTIEUVA KIRJALLISIA OHEITA TAI JOS KÄYTTÖ EI OLE SALLITTUA SOVELLETTAVAN LAINSÄADÄNNÖN TAI MUIDEN ASETUSTEN MUKAAN PAKASSA JOSSA OSTAJA KÄYTTÄÄ TUOTETTA.



PALRAM 's 7 jaars beperkte garantie

Productgegevens: RION Kassen

Palram Applications (1995) Ltd (Bedrijfsnummer: 512106824) met maatschappelijke zetel te Teradion Industrial Park, M.P. Misgav 20174, Israel ("Palram") garandeert dat het product vrij is van materiaal- en fabricagefouten voor een termijn van zeven jaar vanaf de oorspronkelijke aankoopdatum onder de definities en voorwaarden van deze garantie.

1. Voorwaarden

- 1.1 Deze garantie is alleen geldig indien het Product is geïnstalleerd, gereinigd, gebruikt en onderhouden in overeenstemming met de gescreven aanbevelingen van Palram.
- 1.2 Deze garantie geldt niet voor: (1) Verkleuring door gebruik van chemicaliën en/of door andere redenen dan de blootstelling aan zonlicht; (2) schade in verband met klimaat waarin de temperatuur 50° (vijftig graden) Celsius (122° graden Fahrenheit) overschrijdt; (3) schade die wijten aan een lading van meer dan 75 kg / 165 lb per vierkante meter / 17 vierkante voet; (4) schade door blootstelling aan windspelheiden boven 90 km/uur (55 mijl/uur).
- 1.3 Zonder of te wijken van het bovenstaande, zal schade veroorzaakt door gebruik van geweld, onjuist gebruik, ongewijzigd gebruik, nalatig gebruik of onmogelijkheid onderhouden, ongevallen, botsing met vreemde voorwerpen, vandalisme, vernieling, aanpassingen, schilderen, verbinding, lijmen, afdichten op een wijze die niet in overeenstemming is met de handleiding, of schade als gevolg van reiniging met incompatibele schoonmaakmiddelen en geringe afwijkingen van het Product niet vallen onder deze garantie.
- 1.4 Deze garantie geldt niet voor schade als gevolg van "overmacht", inclusief maar niet beperkt tot, hagel, onweer, tornado's, orkanen, sneeuwstormen, overstromingen, gevogjen van brand.
- 1.5 Deze garantie vervalt als structurele onderdelen en onderdelen die worden gebruikt niet compatibel zijn met schriftelijke aanbevelingen van Palram.
- 1.6 Deze garantie geldt alleen voor de oorspronkelijke koper van het Product. Zij geldt niet voor een andere koper of gebruiker van het Product (inclusief, maar niet beperkt tot, elke persoon die het product koopt van de oorspronkelijke koper).

2. Claims en meldingen

- 2.1 Elke garantieclaim dient bij Palram te worden ingediend binnen 30 dagen na de ontdekking van het defecte product, met bijvoeging van het originele koopbewijs en deze garantie.
- 2.2 De eiser moet het Palram mogelijk maken het betrokken product en de constructielocatie zelf te inspecteren, met het product nog in de oorspronkelijke positie en niet verwijderd of verplaatst of op enige/niets wijze veranderd en/of het product terugzenden naar Palram om te laten testen.
- 2.3 Palram behoudt zich het recht om zelfstandig de oorzaak van een probleem te onderzoeken.

3. Compensatie

- 3.1 Indien een claim onder deze garantie goed is aangeneemd en door Palram is goedgekeurd, mag de koper, naar Palrams keuze, ofwel (a) een vervangend product of onderdeel(en) en aanschriften / of (b) het aankoopbedrag van het oorspronkelijke product of onderdeel(en) terugkrijgen, alles in overeenstemming met het volgende schema:

Periode na aankoop	Vervangende product of onderdeel(en) en Teruggave	Teruggave
Vanaf de aankoopdatum tot het eind van 1e jaar	Gratis	100%
Einde van 1' jaar tot einde van 2' jaar	koper betaalt 15% van het oorspronkelijke aankoopbedrag	85%
Einde van 2' jaar tot einde van 3' jaar	koper betaalt 30% van het oorspronkelijke aankoopbedrag	70%
Einde van 3' jaar tot einde van 4' jaar	koper betaalt 45% van het oorspronkelijke aankoopbedrag	55%
Einde van 4' jaar tot einde van 5' jaar	koper betaalt 60% van het oorspronkelijke aankoopbedrag	40%
Einde van 5' jaar tot einde van 6' jaar	koper betaalt 75% van het oorspronkelijke aankoopbedrag	25%
Einde van 6' jaar tot einde van 7' jaar	koper betaalt 85% van het oorspronkelijke aankoopbedrag	15%

- 3.2 Voor alle duidelijkheid, de berekening voor de bepaling van de compensatie voor defecte onderdeel(en), volgens het bovenstaande schema, zal worden gebaseerd op de bijdrage van het defecte onderdeel op de oorspronkelijke kosten van het product. Palram behoudt zich het recht voor vervangingen te leveren indien het product of enig deel daarvan niet beschikbaar of verouderd is.
- 3.3 Deze garantie dekt geen kosten en uitgaven van de verwijdering en installatie van het Product of balastingen of verzendkosten of enige andere directe of indirecte schade(s) die kan/kunnen voortvloeien uit het defect van het product.

4. Algemene voorwaarden en beperkingen

- 4.1 ANDERS DAN SPECIEK IN DEZE GARANTIE AANGEGEVEN, ZIJN ALLE ANDERE GARANTIES, HETZELF EXPLICIT OF IMPLICIT, INCLUSIEF ALLE IMPLICITE GARANTIES VAN VERKOOPBAARHEID OF GESCHIKTHEID VOOR EEN BEPALD DOEL, UITGESLOTEN VOOR ZOVER DE WET DIT TOELAAT.
- 4.2 BEHALVE WAAR WAT SPECIEK HEBBEN AANGEGEVEN IN DEZE GARANTIE, ZAL PALRAM NIET VERANTWOORDELIJK VOOR VERLES OF SCHADE DIE DE KOPER LIDT, DIRECT OF INDIRECT, OF ALS GEVOLG VAN HET GEBRUIK, OF OP WEIKE ANDERE WIJZE DAN OOK IN VERBAND MET HET PRODUCT.
- 4.3 ALS HET PALRAM VERBODEN IS ONDER DE TOEPASSSELIJKE WETGEVING DE GARANTIES VAN VERKOOPBAARHEID OF GESCHIKTHEID UITTE SLUTTEN VOOR EEN BEPALD DOEL, MET BETREKKING TOT HET PRODUCT, IS DE DUUR VAN ALLE DERGEELIJKE IMPLICITE GARANTIES UITDRUKKELIJK BEPERKT TOT DE DUUR VAN DEZE GARANTIE OF, INDIEN LANGER, TOT DE MAXIMALE PERIODE VERBODEN DE TOEPASSSELIJKE WETGEVING.
- 4.4 DE KOPER IS ZELF VERANTWOORDELIJK OM TE BEPALLEN OF HET HANTIEREN, DE OPSLAG, MONTAGE, INSTALLATIE OF HET GEBRUIK VAN HET PRODUCT OF ELKE LOCATIE, VERKRIJVEN IN PASSEND IS VOOR HET DOEL, OF PASSEND ONDER DE GEVEGEN OMSTANDIGHEDEN IS. PALRAM NIET VERANTWOORDELIJK VOOR ENIGE SCHADE OF LETSEL, AAN DE KOPER, EEN ANDERE PERSOON OF ENIGE ANDERE ZAKEN ALS GEVOLG VAN ONDOELMATIG GEBRUIK, OPSLAG, INSTALLATIE, MONTAGE, OF HET GEBRUIK VAN HET PRODUCT OF HET NIET VOLGEN VAN DE SCHRIFTELIJKE AANWIJZINGEN BETREFFENDE HET HANTIEREN, OPSLAG, INSTALLATIE, MONTIEREN EN GEBRUIK VAN HET PRODUCT.
- 4.5 TENZU UITDRUKKELIJK ANDERS DOOR PALRAM AANGEGEVEN, IS HET PRODUCT ALLEEN BEDOELD VOOR NORMAAL HUISHOUDLIJK GEBRUIK. PALRAM IS NIET VERANTWOORDELIJK VOOR VERLES, SCHADE, KOSTEN OF UITGAVEN ALS GEVOLG VAN HET GEBRUIK VAN HET PRODUCT VOOR ENIG DOEL, DAT NIET IS AANBEVOLEN IN DE SCHRIFTELIJKE INSTRUCIES OF DAT NIET IS TOEGESTAN VAN WEEGE ENIGE TOEPASSSELIJKE WETGEVING OF ANDERE GEBRUIKEN OP DE LOCATIE WAAR DE KOPER HET PRODUCT ZAL GEBRUIKEN.



Garantía limitada de 7 años de Palram

Angben zum Produkt: Invernaderos de RION

ES

Palram Applications (1995) Ltd (Número de la compañía: 512106824) cuya oficina registrada se encuentra en Teradion Industrial Park, M.P. Mitsgav 20174, Israel ("Palram") garantiza que el Producto no tendrá defectos de material o de fabricación durante un periodo de siete años desde la fecha de compra original sujeto a las definiciones, términos y condiciones contenidos en esta garantía.

1. Condiciones

- 1.1 Esta garantía solo será válida si el Producto es instalado, limpiado, manipulado y mantenido de acuerdo a las recomendaciones por escrito de Palram.
- 1.2 Sin derogar lo anterior, los daños causados por el uso de la fuerza, manipulación incorrecta, uso inapropiado, uso o montaje o mantenimiento negligentes, accidentes, impacto de objetos extraños, vandalismo, contaminantes, alteración, pintado, conexión, pegado, sellado no de acuerdo al manual del usuario, o daños resultantes de la limpieza con detergentes incompatibles y desviaciones menores del Producto no están cubiertos por esta garantía.
- 1.3 Esta garantía no se aplica a daños resultantes de "fuerza mayor", que incluye entre otros, granizo, tormenta, tornado, huracán, ventisca, inundación, efectos del fuego.
- 1.4 Esta garantía es nula si los componentes o piezas estructurales utilizados no son compatibles con las recomendaciones escritas de Palram.
- 1.5 Esta garantía se aplica solamente al comprador normal del Producto. No se extiende a cualquier otro comprador o usuario del Producto (incluyendo, entre otros, cualquier persona que adquiera el Producto desde el comprador original).

2. Reclamaciones y notificaciones

- 2.1 Toda reclamación de la garantía debe ser notificada por escrito a Palram lo antes que sea posible razonablemente después de descubrir el Producto defectuoso, adjuntando el tique de venta original y esta garantía.
- 2.2 El reclamante debe permitir a Palram inspeccionar el Producto pertinente y el sitio de la instalación en sí mismo mientras el Producto está todavía en su posición original y no se ha retirado ni movido o alterado de ningún modo y/o devolver el Producto a Palram para evaluarlo.
- 2.3 Palram se reserva el derecho a investigar la causa de cualquier fallo de forma independiente.

3. Compensación

- 3.1 Si una reclamación bajo esta Garantía se notifica apropiadamente y es aprobada por Palram, el comprador, según considere Palram, puede o bien (a) comprar un Producto o piezas/ de recambio; o (b) recibir el reembolso del precio de compra del Producto o la pieza o piezas, todo de acuerdo al siguiente calendario:

El periodo tras la compra	Reembolso del Producto o Pieza /s	Recambio Según
Desde la fecha de compra hasta el final del primer año	Sin costes	100%
Fin del 1.er año hasta el final del 2.º año	El comprador pagará el 15% del precio original de compra	85%
Fin del 2.º año hasta el final del 3.er año	El comprador pagará el 30% del precio original de compra	70%
Fin del 3.er año hasta el final del 4.º año	El comprador pagará el 45% del precio original de compra	55%
Fin del 4.º año hasta el final del 5.º año	El comprador pagará el 60% del precio original de compra	40%
Fin del 5.º año hasta el final del 6.º año	El comprador pagará el 70% del precio original de compra	25%
Fin del 6.º año hasta el final del 7.º año	El comprador pagará el 85% del precio original de compra	15%

- 3.2 Para evitar cualquier duda, el cálculo de la determinación de la compensación por piezas defectuosas, según el calendario de arriba, se basará en la contribución de la pieza defectuosa al coste original del Producto. Palram se reserva el derecho de proporcionar sustituciones si el Producto o cualquier pieza del mismo no está disponible o es obsoleta.
- 3.3 Esta garantía no cubre ningún coste ni gasto de la retirada e instalación del Producto o impuestos o gastos de envío ni cualquier otra pérdida/s directa o indirecta que pueda resultar del defecto del Producto.

4. Condiciones generales y limitaciones

- 4.1 APARTE DE LO QUE SE HA AFIRMADO ESPECÍFICAMENTE EN ESTA GARANTÍA, TODAS LAS DEMÁS GARANTÍAS, TANTO EXPRESAS COMO IMPLÍCITAS, INCLUYENDO TODAS LAS GARANTÍAS IMPLÍCITAS DE COMERCIABILIDAD O IDONEIDAD PARA UN PROPÓSITO EN PARTICULAR SE EXCLUYEN EN LA EXTENSIÓN EN QUE LO PERMITA LA LEY.
- 4.2 EXCEPTO DONDE LO HAYAMOS DECLARADO ESPECÍFICAMENTE EN ESTA GARANTÍA, PALRAM NO SERÁ RESPONSABLE DE CUALQUIER PÉRDIDA O DAÑOS QUE SUFRAN EL COMPRADOR DIRECTAMENTE, INDIRECTAMENTE O COMO CONSECUENCIA DE UTILIZAR EL PRODUCTO O EN CONEXIÓN DE CUALQUIER MODO CON EL MISMO.
- 4.3 SI SE PROHIBE A PALRAM, BAJO CUALQUIER LEY APLICABLE, EXCLUIR LAS GARANTÍAS IMPLÍCITAS DE COMERCIABILIDAD O IDONEIDAD PARA UN PROPÓSITO EN PARTICULAR CON RELACIÓN AL PRODUCTO, LA DURACIÓN DE DICHAS GARANTÍAS IMPLÍCITAS SE LIMITA EXPRESAMENTE A LA DURACIÓN DE ESTA GARANTÍA, O SI ES MÁS TIEMPO, EL PERIODO MÁXIMO REQUERIDO POR LA LEY APLICABLE.
- 4.4 EL COMPRADOR ES RESPONSABLE ÚNICAMENTE DE DETERMINAR SI LA MANIPULACIÓN, ALMACENAMIENTO, MONTAJE, INSTALACIÓN O USO DEL PRODUCTO ES SEGURO Y APROPIADO EN CUALQUIER UBICACIÓN. PARA CUALQUIER UBICACIÓN DADA O EN CUALQUIER CIRCUNSTANCIA DADA, PALRAM NO ES RESPONSABLE POR CUALQUIER DAÑO O LESIÓN DEL COMPRADOR, CUALQUIER OTRA PERSONA O CUALQUIER PROPIEDAD QUE RESULTE DE LA MANIPULACIÓN, ALMACENAMIENTO, INSTALACIÓN, MONTAJE O USO INADECUADOS DEL PRODUCTO O NO SEGUIR LAS INSTRUCCIONES ESCRITAS ACERCA DE LA MANIPULACIÓN, ALMACENAMIENTO, INSTALACIÓN, MONTAJE Y USO DEL PRODUCTO.
- 4.5 A MENOS QUE SE INDIQUE EXPRESAMENTE LO CONTRARIO POR PALRAM, EL PRODUCTO ESTÁ PREVISTO SOLO PARA USO RESIDENCIAL NORMAL. PALRAM NO ES RESPONSABLE POR NINGUNA PÉRDIDA, DAÑO, COSTE O GASTO RESULTANTE DE CUALQUIER USO DEL PRODUCTO PARA CUALQUIER PROPÓSITO QUE NO ESTE RECOMENDADO POR LAS INSTRUCCIONES ESCRITAS O QUE NO ESTÉ PERMITIDO POR CUALQUIER LEGISLACIÓN APLICABLE U OTROS CÓDIGOS EN VIGOR EN LA UBICACIÓN DONDE USARÁ EL PRODUCTO EL COMPRADOR.