

ZDF003/ZDF004

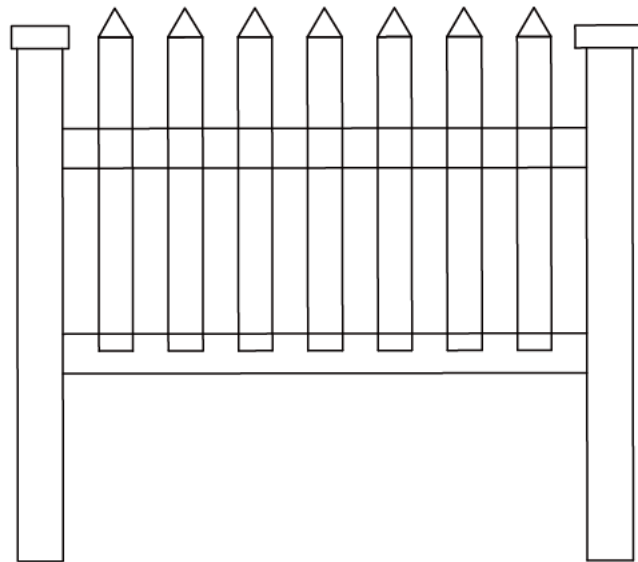

INSTRUCTION MANUAL

- A.4"X4" Flat Cap
- B.4"X4" Post
- C.7/8" X 3" Picket & Caps
- D.2" X 3.5" Rail
- E.2" X 3.5" Connector & screw

Tool May Need

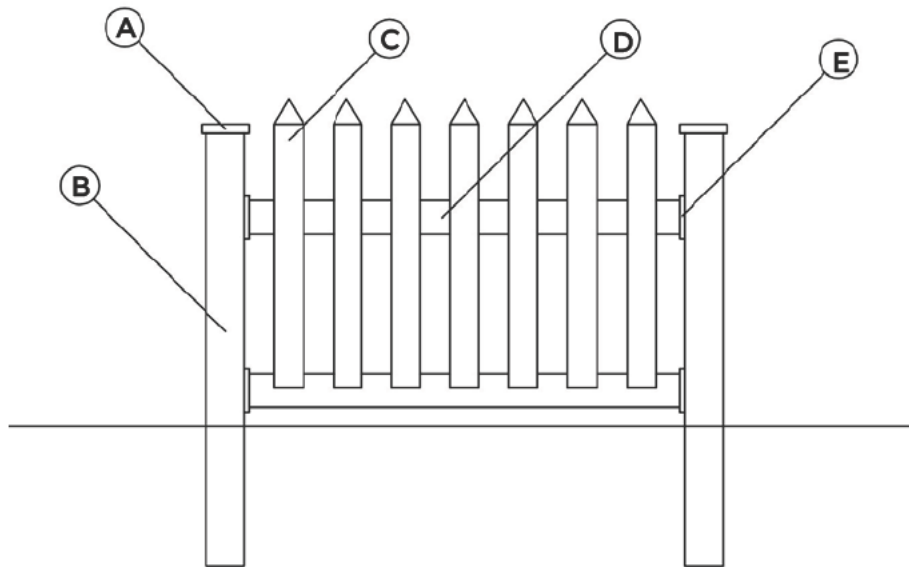

1.SETTING POSTS

STEP1

Dig a post holes(15"deep).
SET POSTS IN CONCRETE.

STEP 2

Position the post in the hole. The posts should be centered in the hole and must be square with the fence line so that when the rails are inserted into the posts they will parallel the string line. Check the post on two adjacent sides with a carpenter's level and adjust as necessary to make sure it is plumb. The fence height above grade is determined at this time as well. We recommend Post inserted 15" underground

(There is a mark at 15" and can be inserted into the mark)

STEP 3

Pour concrete around post. Once the concrete is completely dry,fill the balance of the hole with dirt.

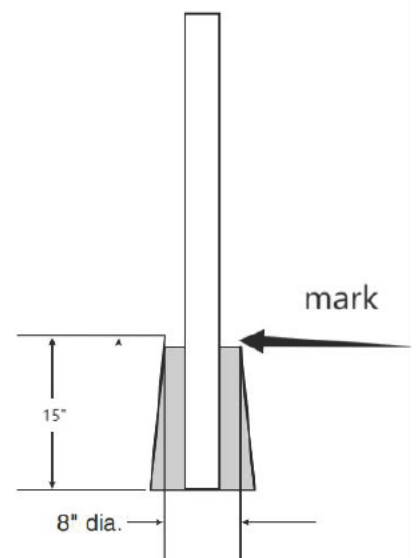

2.SETTING RAILS

STEP1

Insert Connector (E) into Rail (D)

STEP 2

Confirm location of next Post via Rail (usually 46" wide)

STEP 3

Use screws to fix Rail (D) to Post (B) through Connector (E)

Notice!!! :

There are 2 openings on the upper rail and 1 opening on the lower rail.

There is a mark on the Post that allows you to fix the Rail location.

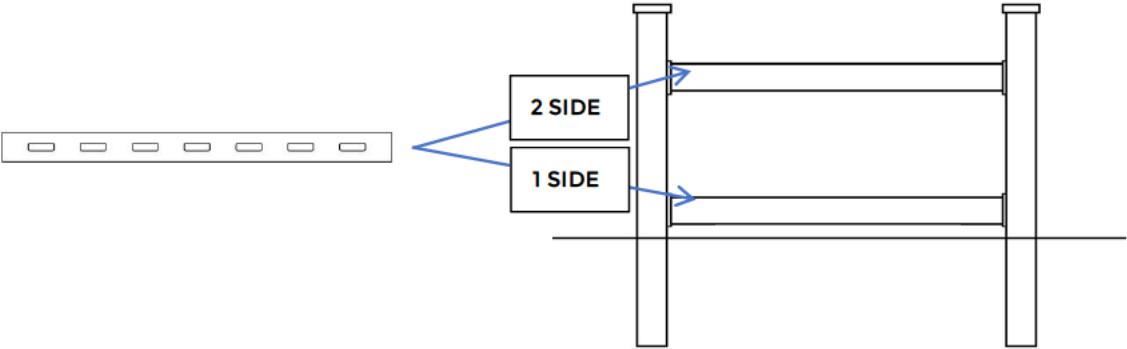
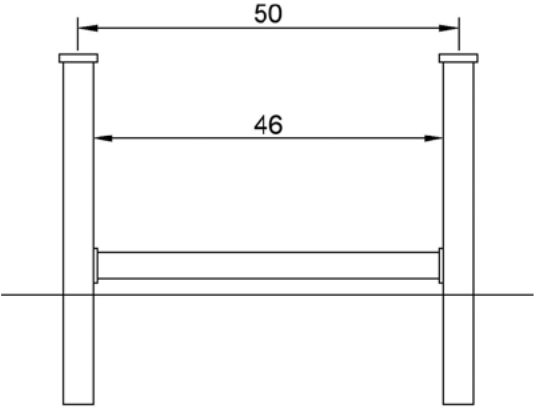
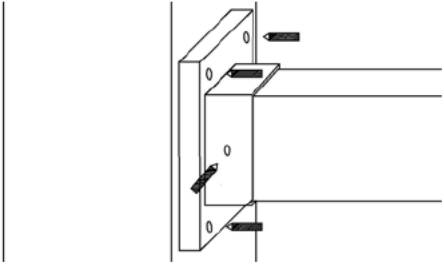
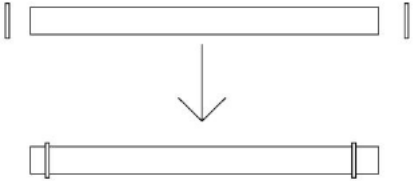

3.INSERT PICKET

STEP1

As shown in the picture, insert 7 Pickets
**Please note that once plugged in it will
be difficult to unplug.**

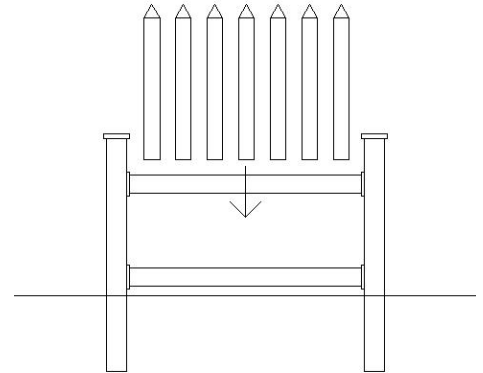

4.REPEAT

Repeat the above steps until all fences are
installed.

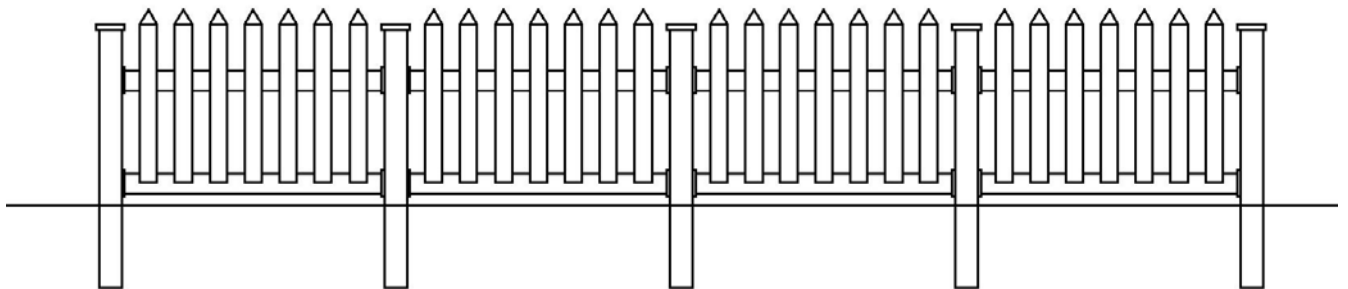
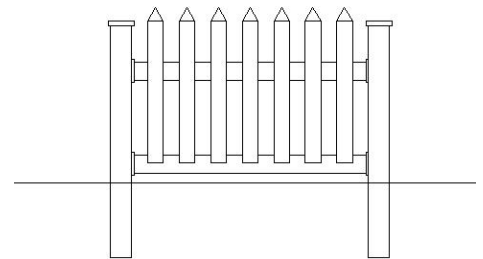



MAINTENANCE AND CARE

Hardware may loosen over time. Periodically check to make sure all connections are tight. Re-tighten if necessary.

Do not dispose of any packaging or contents of the shipping carton until assembly is completed to avoid accidentally discarding small parts or hardware.



WARRANTY INFORMATION

Warranty Coverage: Our warranty provides protection against manufacturing defects in materials and workmanship for a specified period from the date of purchase, as outlined in the accompanying warranty documentation.

Exclusions: The warranty does not cover damages resulting from misuse, negligence, accidents, normal wear and tear, unauthorized repairs or modifications, improper assembly, or failure to adhere to the care and maintenance guidelines provided.

Warranty Claim Process

To initiate a return on Amazon, please follow these steps:

- 1 Log into your Amazon account and go to the "Your Orders" section.
- 2 Locate the order containing the item you wish to return.
- 3 Contact our customer service for assistance in obtaining a prepaid return label.
- 4 Once you receive the return label, securely affix it to the package.
- 5 You can then choose to drop off the package at a designated carrier location or arrange for a pickup.
- 6 After we receive and inspect the returned product, we will initiate the refund process.
- 7 The refund will be credited back to the original payment method used during the purchase.
- 8 Typically, refunds are processed within 3-5 business days.



Contact Information

If you have any questions, concerns, or need assistance, please reach out to our customer support team using the contact information provided below:

Customer Support Email

support@sunvivi.com
