

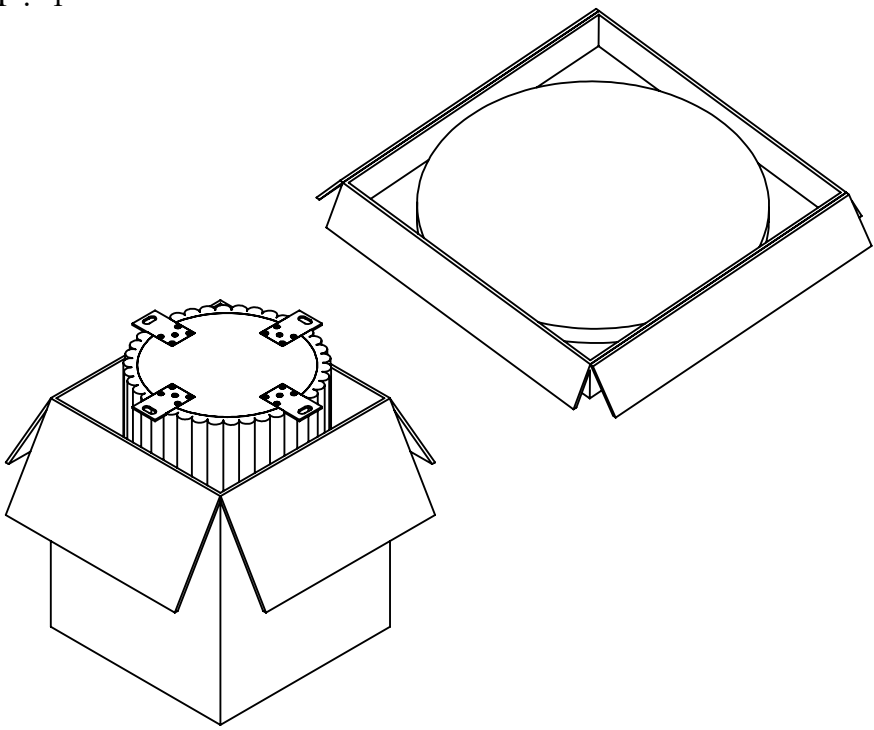





STEP :- 1



END TABLE			
S.NO.	ITEM	DESCRIPTION	QUANTITY
1		TOP	1
2		BASE	1
3		JCB ALLEN BOLT M6 X 20 mm	4
4		WASHER M8 X 16 mm	4
5		ALLENKEY 4mm	1

STEP :- 2

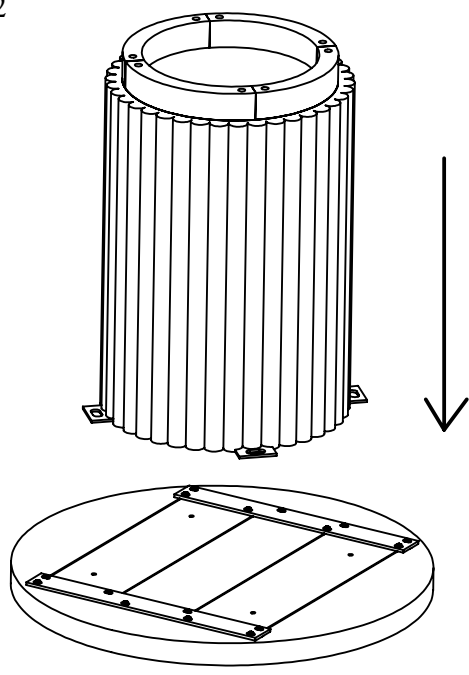

STEP :- 3

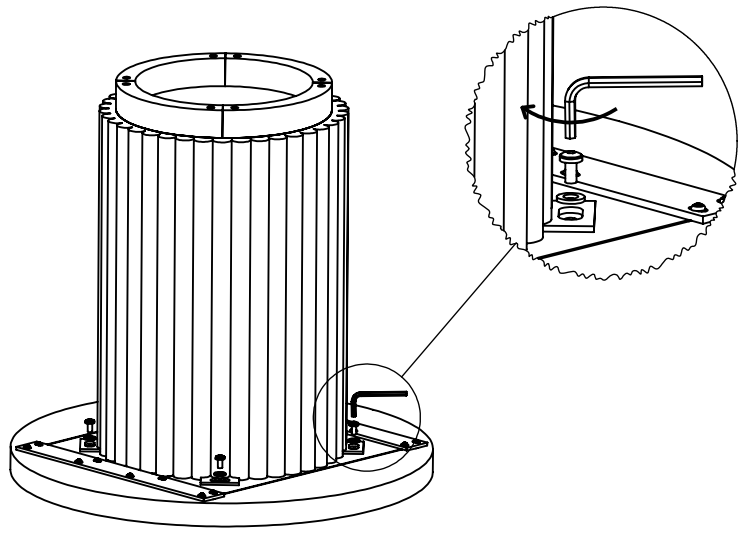

STEP :- 4

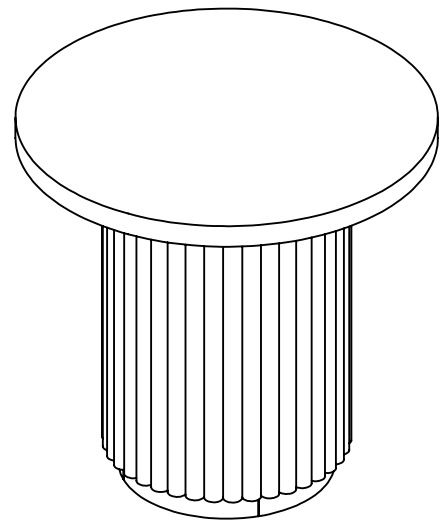

**NOTE :- ASSEMBLE PRODUCT ON MAT OR CARPET**