

## My Bed Now

Thank you for purchasing from mybednow.com We hope you get years of enjoyment from your new bed. The unique brushing process highlights the woods natural grain. All our wood is plantation grown. No two pieces of wood are the same, enjoy the natural beauty of wood, every piece of wood has unique grain and color and knots, these differences in texture and color create the look only solid wood provides.

Our web site, [www.mybednow.com](http://www.mybednow.com) has a link with video instructions to show you how easy it is to assemble your bed.

The success or failure of a product sold on the internet is a direct reflection of positive or negative reviews. We would be grateful if you could post a positive review and help this products success, thank you for your help.

From all of us at My Bed Now, Thank you for your support.

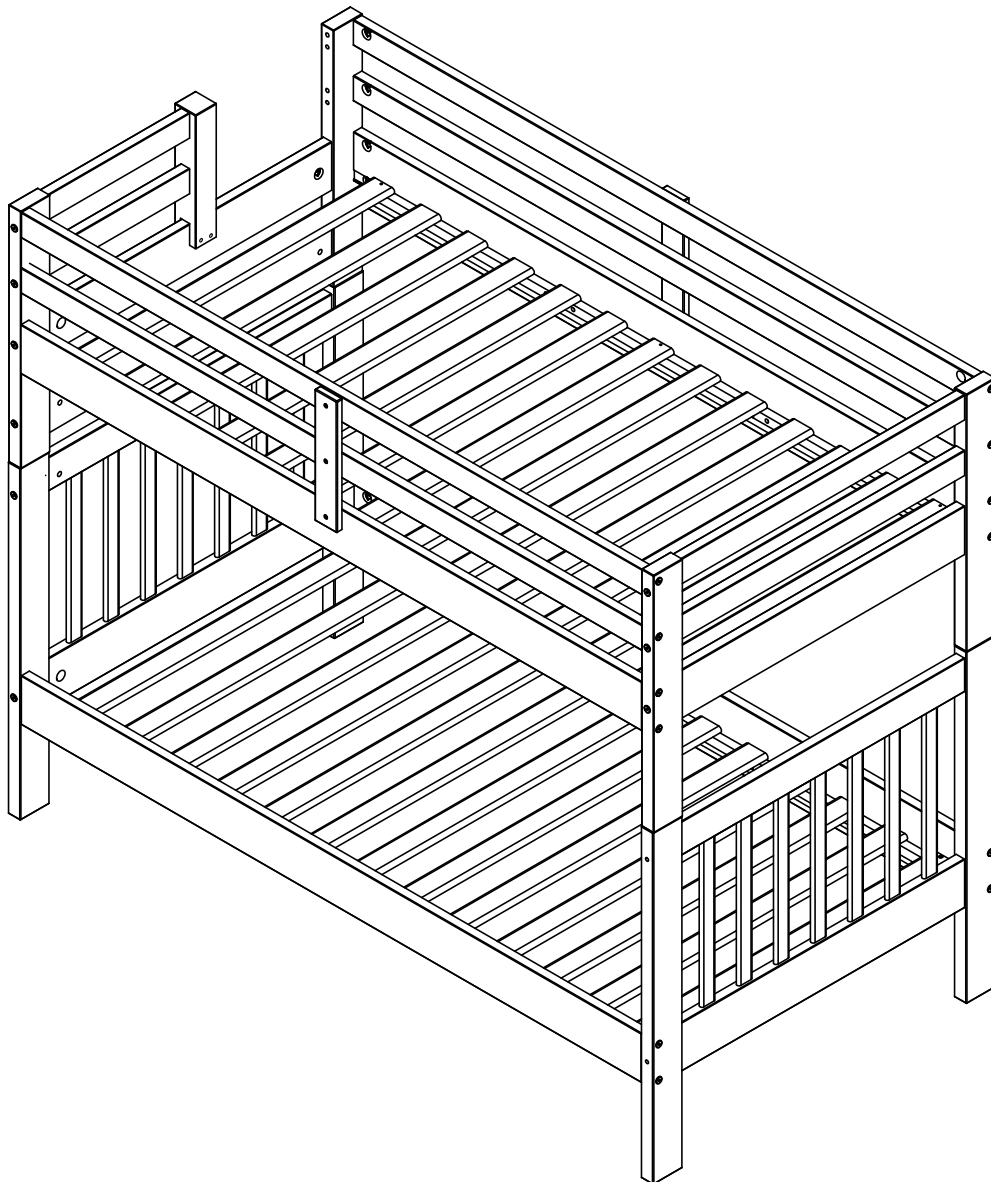

# OLYMPUS BUNK BED



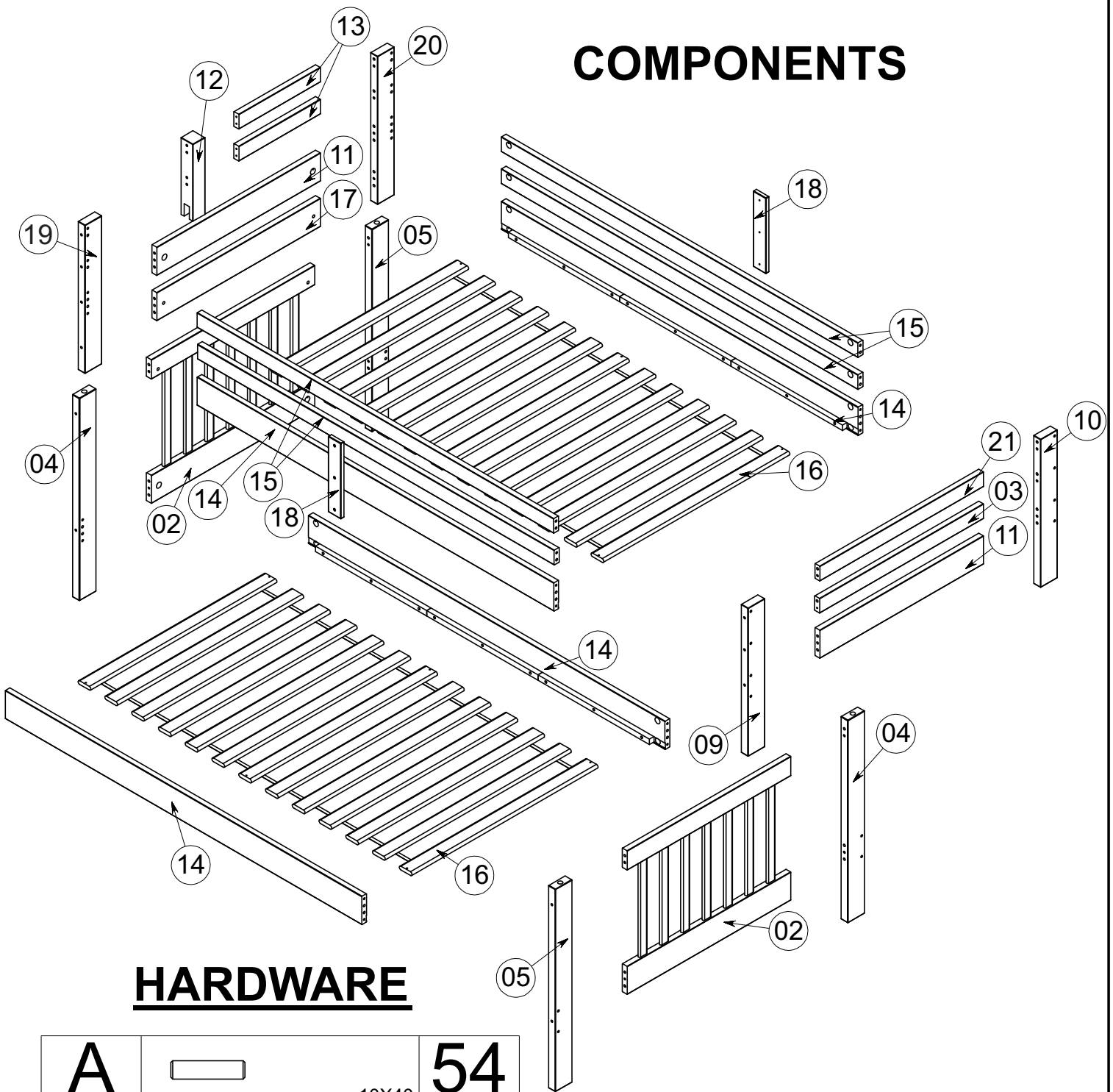

# COMPONENTS

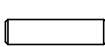
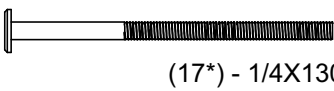
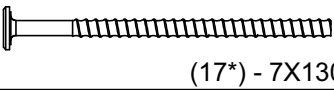
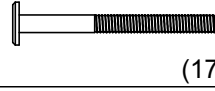
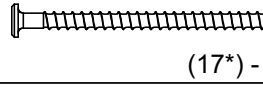
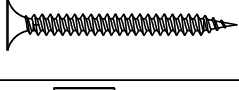

## HARDWARE

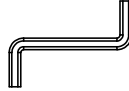
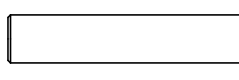
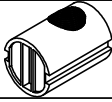
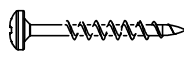
<b>A</b>		10X40	<b>54</b>
<b>B</b>		(17*) - 1/4X130	<b>16</b>
<b>C</b>		(17*) - 7X130	<b>04</b>
<b>D</b>		(17*) - 1/4X80	<b>24</b>
<b>E</b>		(17*) - 7X100	<b>04</b>
<b>F</b>		CC 4X35	<b>12</b>
<b>G</b>		1/4X25	<b>32</b>

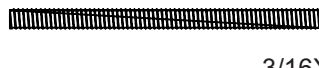
<b>H</b>		15X40X4	<b>02</b>
<b>I</b>		19,5X90	<b>04</b>
<b>J</b>		11X19	<b>08</b>
<b>K</b>		CP 4X30*	<b>08</b>
<b>L</b>		(17*) 3/16X12	<b>04</b>
<b>M</b>		3/16X78	<b>02</b>

# STEP 1

REMOVE PACKING BOARDS

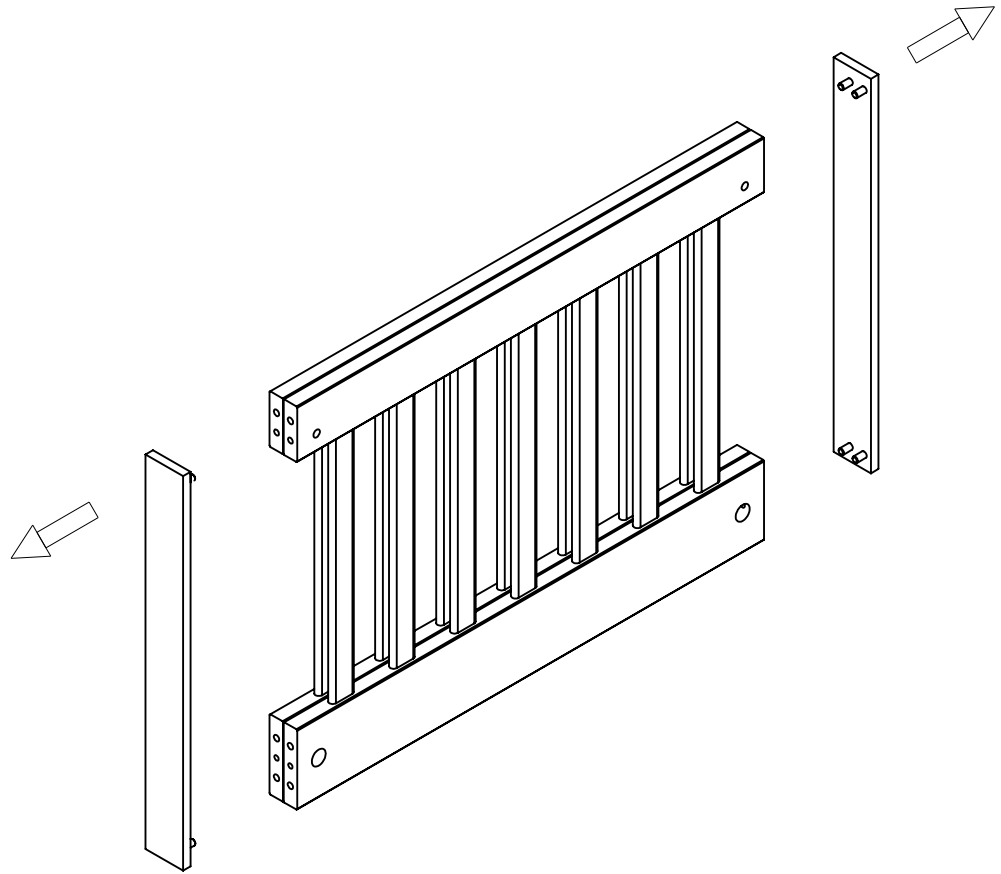

# STEP 2

INSERT DOWEL (A) TO ALL COMPONENTS SHOWN BELOW

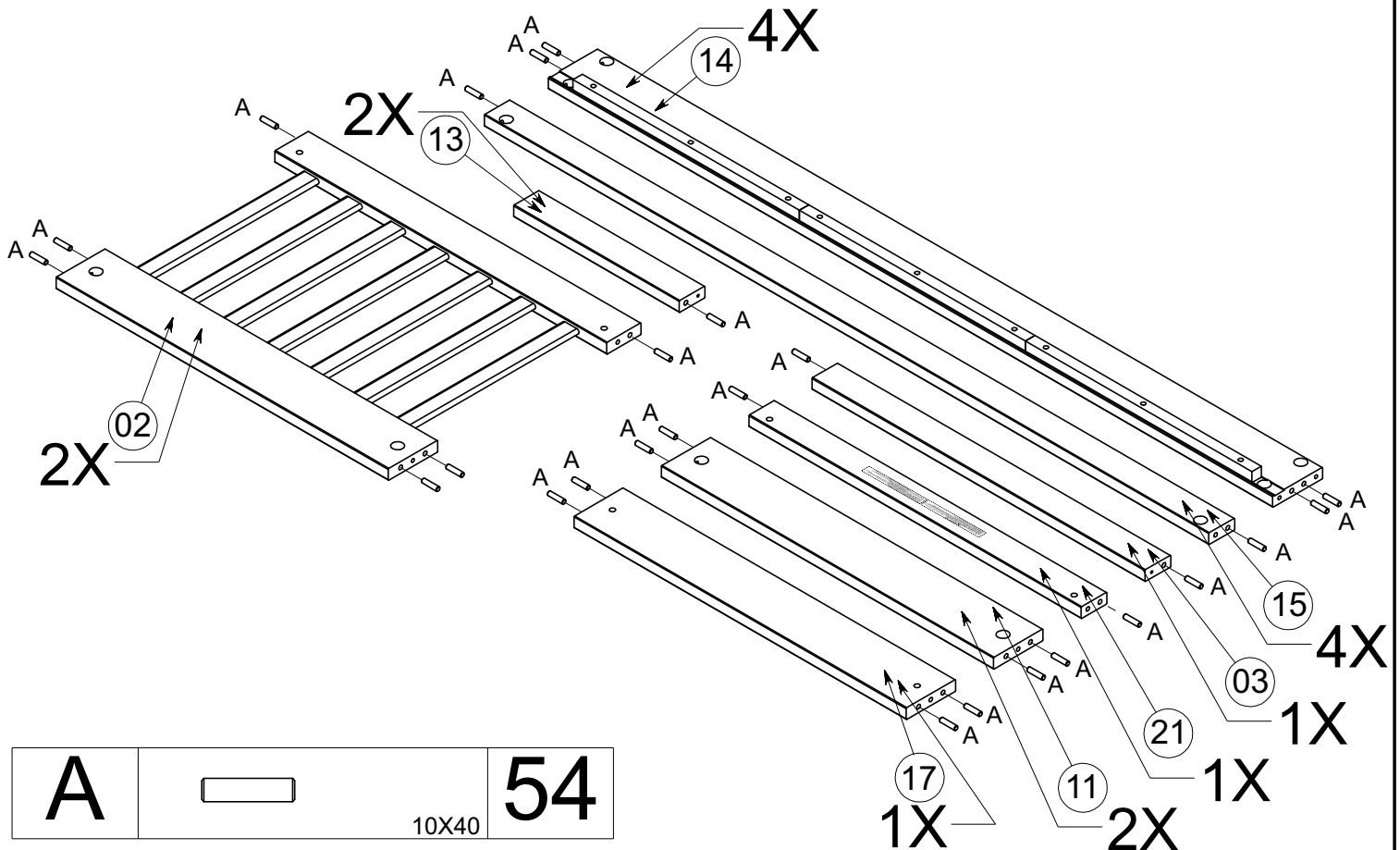

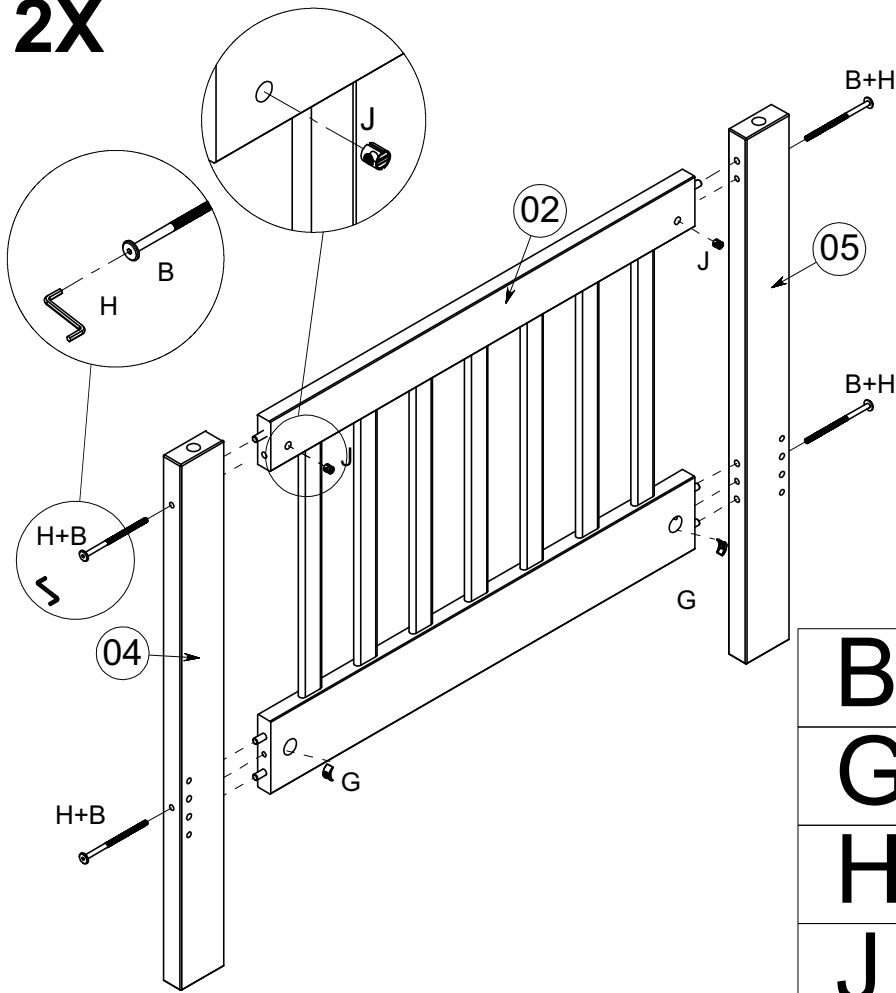

**2X**



**STEP 3**

Headboards x2

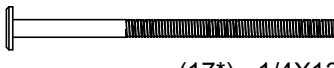
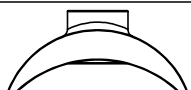
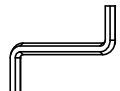
INSERT CROSS BOARDS  
PANEL (02) TO POSTS (04, 05)  
TIGHTEN BOTTOM CROSS BOARD  
(02) USING BOLT (B) & NUT (G)  
TIGHTEN TOP CROSS BOARD (02)  
USING BOLT (B) & NUT (J)  
REPEAT FOR SECOND  
HEADBOARD

<b>B</b>	 (17*) - 1/4X130	<b>08</b>
<b>G</b>	 1/4X25	<b>04</b>
<b>H</b>	 15X40X4	<b>01</b>
<b>J</b>	 11X19	<b>04</b>

**STEP 4**

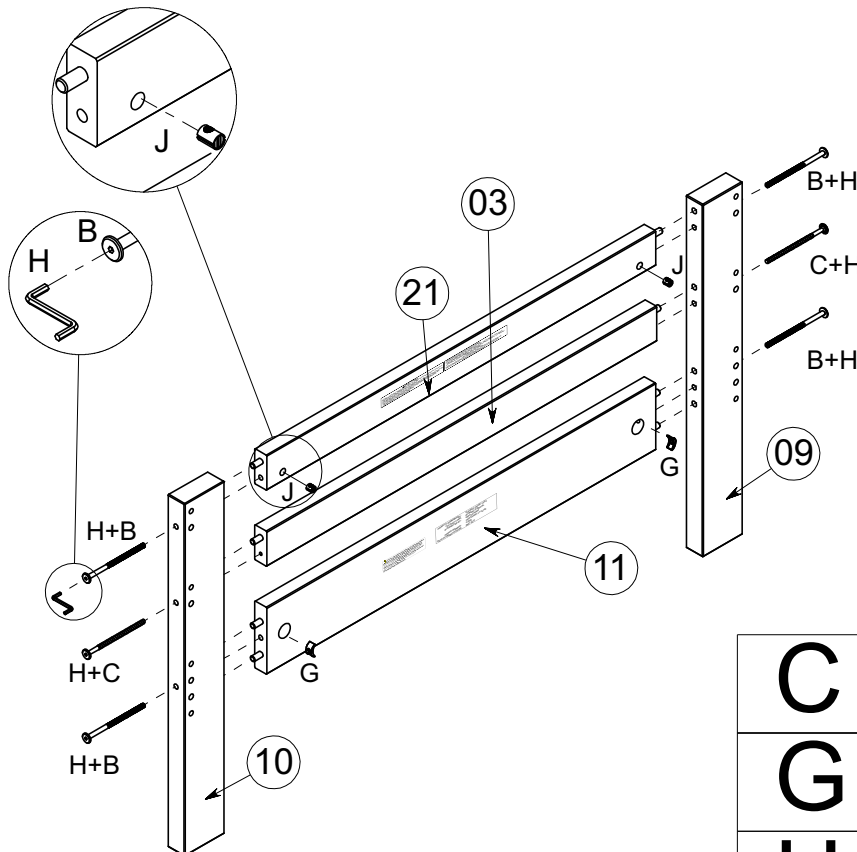



INSERT CROSS BOARDS (21, 03, 11)  
TO POSTS (09, 10)

TIGHTEN CROSS BOARD (21) USING  
BOLT (B) & NUT (J)

TIGHTEN CROSS BOARD (03)  
USING LAG BOLT (C)

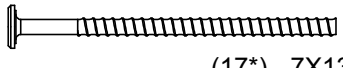
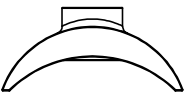
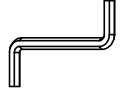
TIGHTEN CROSS BOARD (11)  
USING BOLT (B) & NUT (G)

<b>C</b>	 (17*) - 7X130	<b>02</b>
<b>G</b>	 1/4X25	<b>02</b>
<b>H</b>	 15X40X4	<b>01</b>
<b>J</b>	 11X19	<b>02</b>

<b>B</b>	 (17*) - 1/4X130	<b>04</b>
----------	--	-----------

## STEP 5

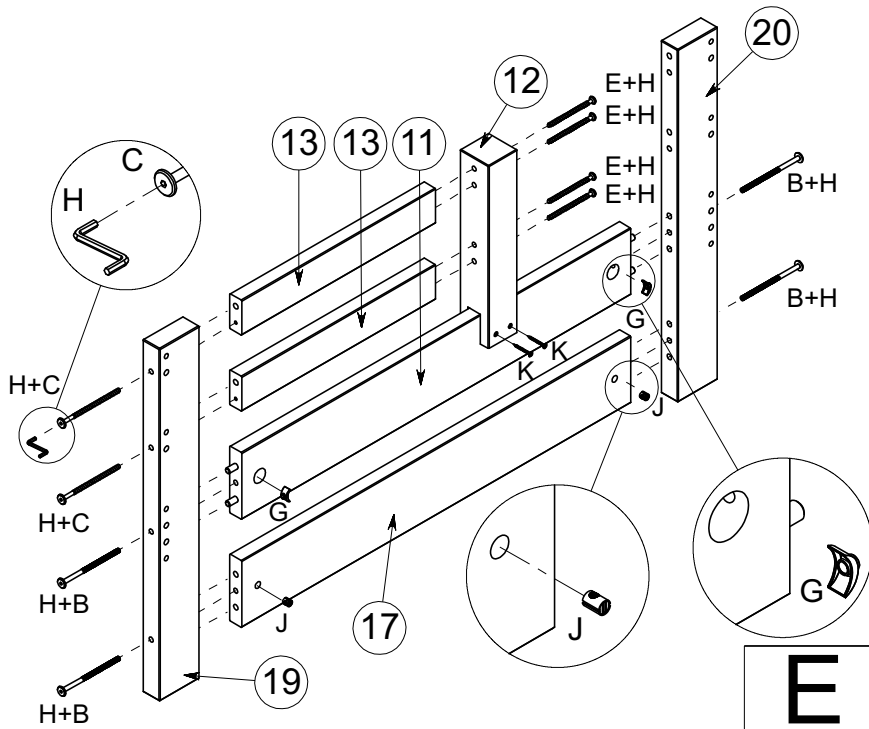



INSERT CROSS BOARDS (11, 17) TO POSTS (19, 20)

TIGHTEN CROSS BOARD (11) USING BOLTS (B) & NUTS (G)

TIGHTEN CROSS BOARD (17) USING BOLTS (B) & NUTS (J)

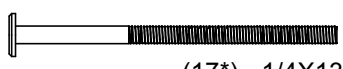
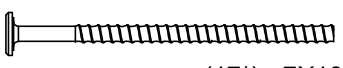
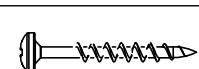
ATTACH BOARDS (13X2) TO POST (12) USING LAG BOLTS (E) THEN ATTACH ASSEMBLED PIECES (13X2, 12) TO EITHER POST (19) OR POST (20) (DEPENDING ON THE SIDE YOU CHOOSE THE LADDER or STAIRCASE TO ATTACH) USE LAG BOLTS (C)

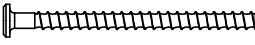
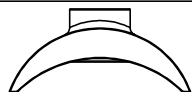
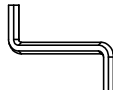
<b>B</b>	 (17*) - 1/4X130	<b>04</b>
<b>C</b>	 (17*) - 7X130	<b>02</b>
<b>K</b>	 CP 4X30*	<b>02</b>

<b>E</b>	 (17*) - 7X100	<b>04</b>
<b>G</b>	 1/4X25	<b>02</b>
<b>H</b>	 15X40X4	<b>01</b>
<b>J</b>	 11X19	<b>02</b>

## STEP 6

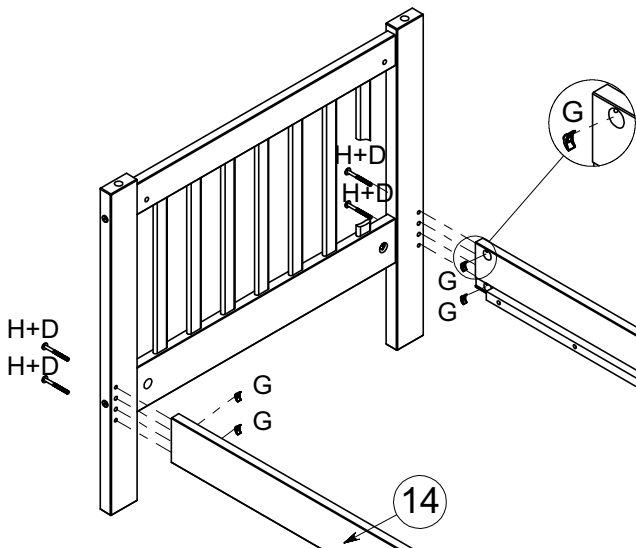

ATTACH SIDERAILS (14) TO HEADBOARDS USING BOLTS (D) & NUTS (G)

**\*\* SEE FULL CONVERSION INSTRUCTIONS IF ASSEMBLING A TWIN OVER FULL \*\***

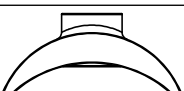
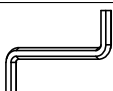
<b>D</b>	 (17*) - 1/4X80	<b>08</b>
<b>G</b>	 1/4X25	<b>08</b>
<b>H</b>	 15X40X4	<b>01</b>

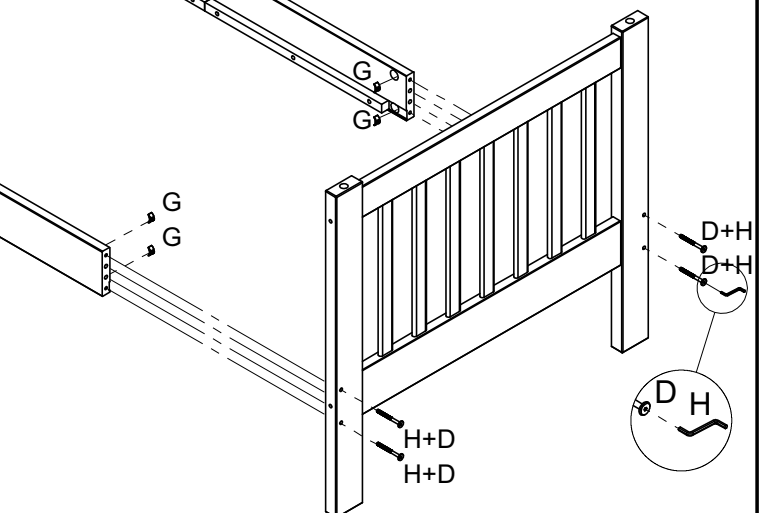



## STEP 7

INSERT LARGE DOWELS (I) IN THE TOP OF HEAD BOARDS

LAY OUT SLAT KIT (16) ON THE CLEAT OF SIDERAILS (14).  
 \*\*BE SURE THE END SLAT ARE FLUSH WITH THE END OF THE CLEAT.

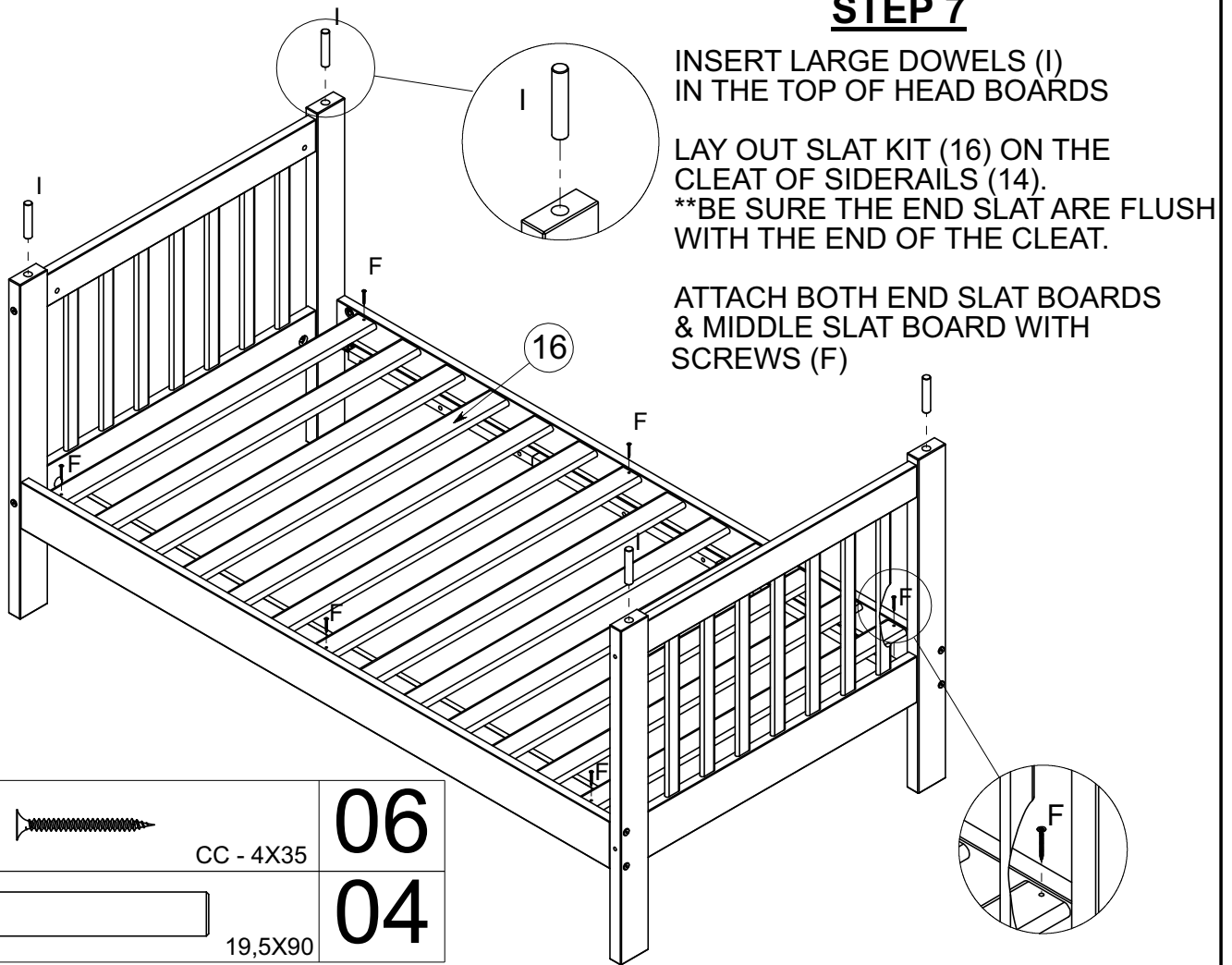
ATTACH BOTH END SLAT BOARDS & MIDDLE SLAT BOARD WITH SCREWS (F)

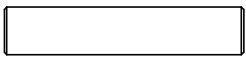

<b>F</b>	 CC - 4X35	<b>06</b>
<b>I</b>	 19,5X90	<b>04</b>

## STEP 8

ATTACH SIDERAILS (14) & GUADRAILS (15) TO FOOTBOARDS USING BOLTS (D) & NUTS (G)

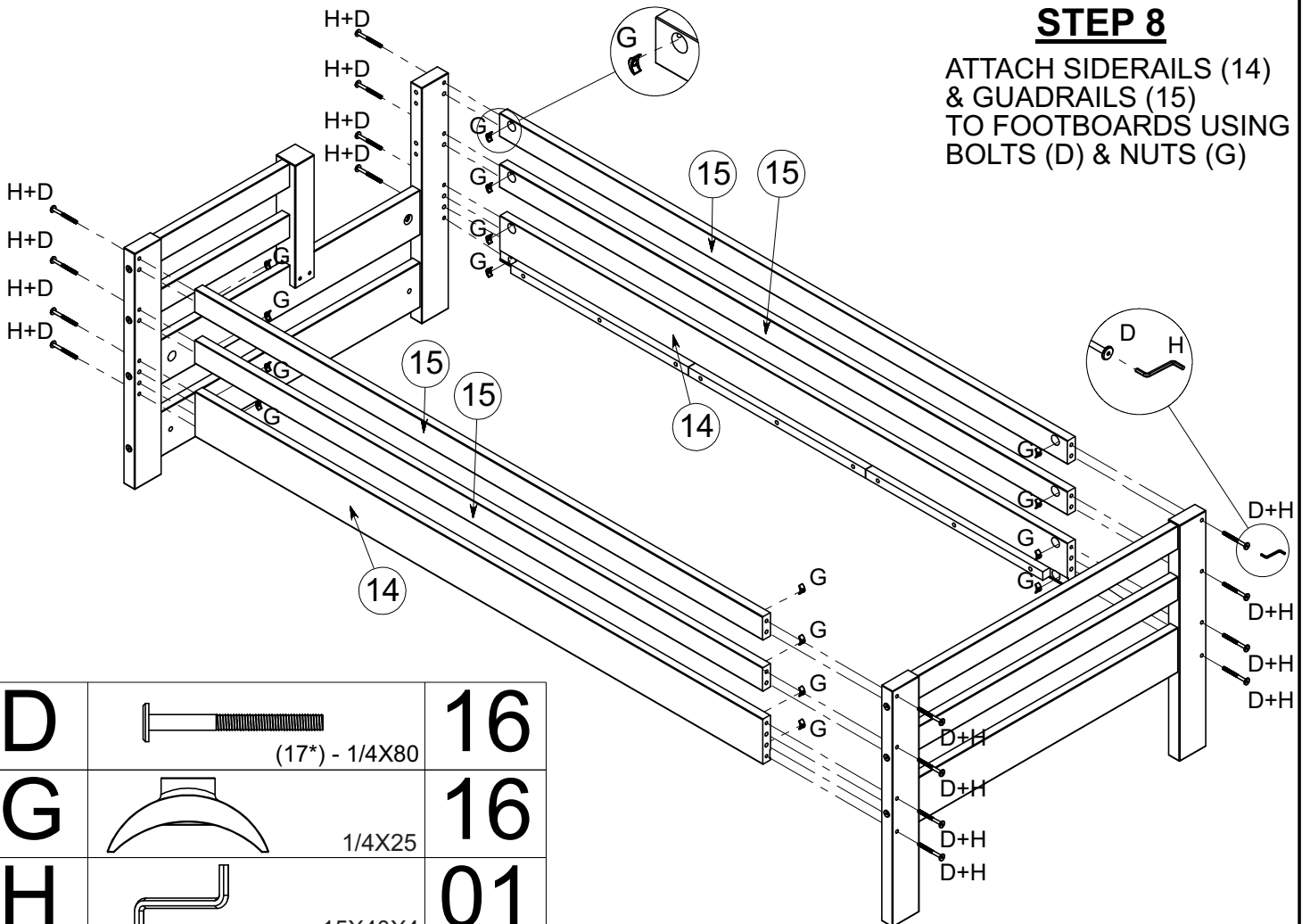

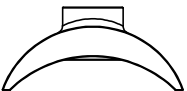
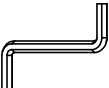
<b>D</b>	 (17*) - 1/4X80	<b>16</b>
<b>G</b>	 1/4X25	<b>16</b>
<b>H</b>	 15X40X4	<b>01</b>

## STEP 9

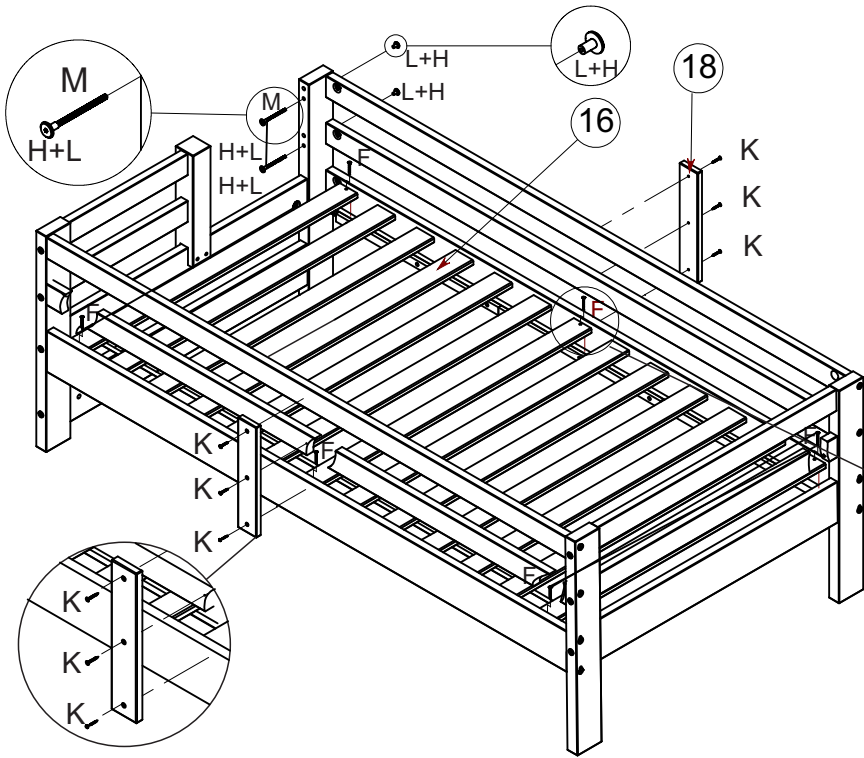



LAY OUT SLAT KIT (16) ON THE CLEAT OF SIDERAILS (14).  
**\*\*BE SURE THE END SLAT ARE FLUSH WITH THE END OF THE CLEAT.**

ATTACH BOTH END SLAT BOARDS & MIDDLE SLAT BOARD WITH SCREWS (F)

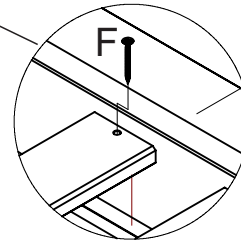
CENTER BOARDS (18) ON GUARDRAILS AND SIDERAILS. ATTACH USING SCREWS (K)

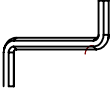
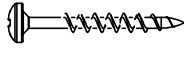

<b>F</b>		CC - 4X35	<b>06</b>
<b>H</b>		15X40X4	<b>02</b>
<b>K</b>		CP 4X30*	<b>06</b>

<b>L</b>		(17*) 3/16X12	<b>02</b>
<b>M</b>		3/16X78	<b>01</b>

## STEP 10

WITH TWO PEOPLE, LIFT THE TOP SECTION & PLACE ON THE HEADBOARDS, INSERTING LARGE DOWELS (L) INTO THE BOTTOM OF FOOTBOARDS.

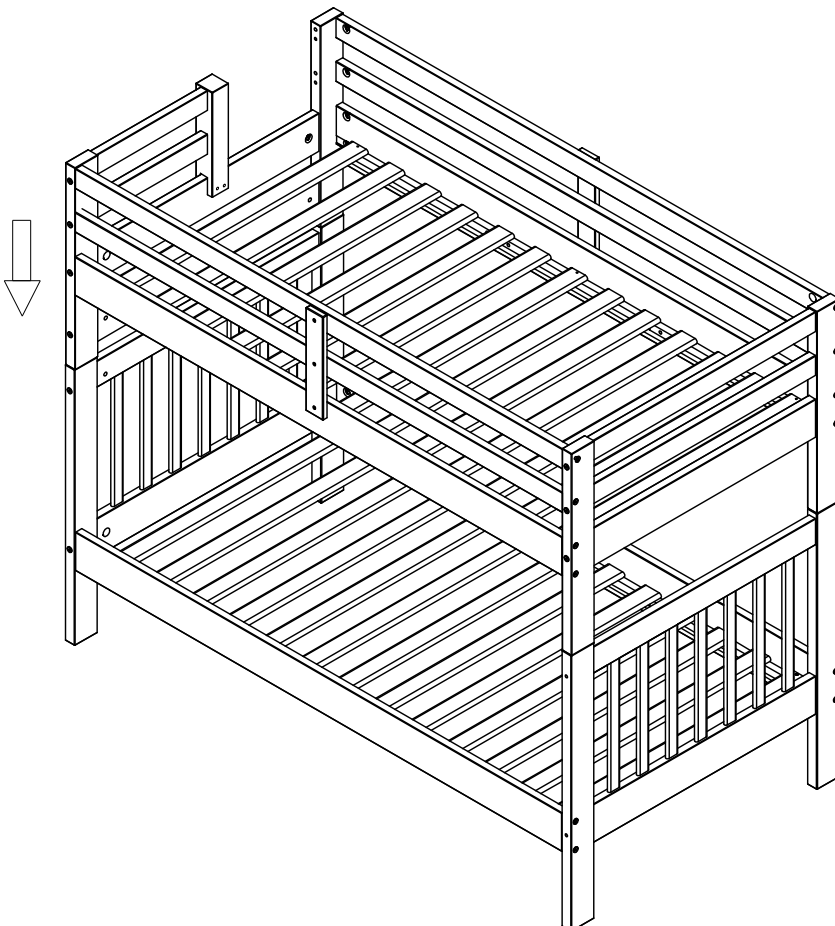

## **OLYMPUS BUNK BED ASSEMBLY**

### **SIZE OF MATTRESS**

THIS BED IS DESIGNATED TO USE A MATTRESS (74" TO 75") LONG, AND (37-1/2" TO 38-1/2") IN WIDTH ON UPPER AND LOWER MATTRESSES AND THE ENCLOSED SLAT KIT SYSTEM.  
THE TOTAL THICKNESS OF MATTRESS AND FOUNDATION MUST NOT EXCEED 9 1/4". NOTE: THERE MUST BE AT LEAST 5" FROM MATTRESS SLEEPING SURFACE TO TOP EDGE OF GUARDRAIL.

### **REPLACEMENT PARTS**

REPLACEMENT PARTS, INCLUDING ADDITIONAL GUARDRAILS, MAY BE OBTAINED DIRECTLY FROM "MY BED NOW"

### **SAFETY WARNINGS**

1. FOLLOW THE INFORMATION ON THE WARNINGS APPEARING ON THE UPPER BUNK END STRUCTURE AND ON THE CARTON. DO NOT REMOVE WARNING LABEL FROM BED.
2. ALWAYS USE THE RECOMMENDED SIZE MATTRESS OR MATTRESS SUPPORT, OR BOTH, TO HELP PREVENT THE LIKELIHOOD OF ENTRAPMENT OR FALLS.
3. SURFACE OF MATTRESS MUST BE AT LEAST 5 INCHES BELOW THE UPPER EDGE OF GUARDRAILS.
4. DO NOT ALLOW CHILDREN UNDER 6 YEARS OF AGE TO USE THE UPPER BUNK.
5. PERIODICALLY CHECK AND ENSURE THAT THE GUARD RAIL, LADDER, AND OTHER COMPONENTS ARE IN THEIR PROPER POSITION, FREE FROM DAMAGE, AND THAT ALL CONNECTORS ARE TIGHT.
6. DO NOT ALLOW HORSEPLAY ON OR UNDER THE BED AND PROHIBIT JUMP ON THE BED.
7. ALWAYS USE THE LADDER FOR ENTERING OR LEAVING THE UPPER BUNK.
8. DO NOT USE SUBSTITUTE PARTS. CONTACT MANUFACTURER OR DEALER FOR REPLACEMENT PARTS.
9. USE OF A NIGHT LIGHT MAY PROVIDE ADDED SAFETY PRECAUTION FOR A CHILD USING THE UPPER BUNK.
10. ALWAYS USE GUARD RAILS ON BOTH LONG SIDES OF THE UPPER BUNK.
11. IF THE BUNK BED WILL BE PLACED NEXT TO A WALL, THE GUARD RAIL THAT RUNS THE FULL LENGTH OF THE BED SHOULD BE PLACED AGAINST THE WALL TO PREVENT ENTRAPMENT BETWEEN THE BED AND THE WALL.
12. PROHIBIT MORE THAN ONE PERSON ON THE UPPER BUNK
13. THE USE OF WATER OR SLEEP FLOTATION MATTRESSES IS PROHIBITED.
14. KEEP THESE INSTRUCTIONS FOR FURNITURE REFERENCE

**STRANGULATION HAZARD** – NEVER ATTACH OR HANG ITEMS TO ANY PART OF THE BUNK BED THAT ARE NOT DESIGNATED FOR USE WITH THE BED: FOR EXAMPLE, BUT NOT LIMITED TO HOOKS, BELTS, AND JUMP ROPES.

**MY BED NOW**  
**P.O BOX 2073**  
**HARTFORD, CT 06145**