

ASSEMBLY INSTRUCTIONS

RECTANGULAR DINING TABLE











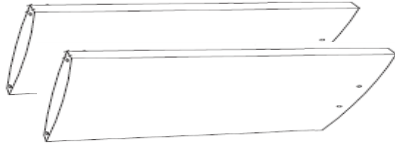

Please read instructions carefully

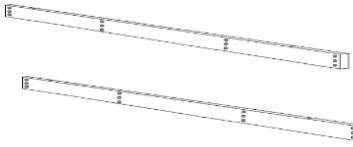
Remove all wrapping materials, staples and packing straps from the carton. Refer to Parts List and Hardware List and ensure they are complete before you start assembling. Place all wooden parts on a clean, flat and soft surface (e.g carpet or rug) to prevent parts from being scratched.

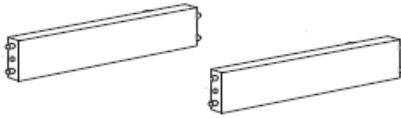
CAUTIONS: 1) DO NOT FULLY TIGHTEN BOLTS AND NUTS UNTIL ALL PARTS HAVE BEEN ASSEMBLED.

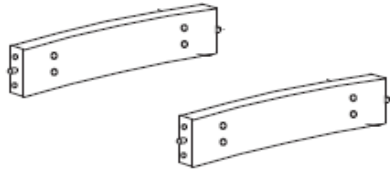
2) DO NOT OVER-TIGHTEN BOLTS AND NUTS .

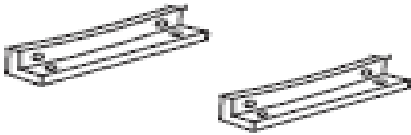
3) KEEP ALL HARDWARE PARTS OUT OF REACH OF CHILDREN.

Designation	Part	Qty	Part List	HARDWARE	Qty	Hardware List
TABLE TOP	P1	1pc		H1	34pcs	 M6x35mm JCBC SCREW
TABLE LEG	P2	2pcs		H2	34pcs	 SPRING WASHER
LONG BRACE	P3	2pcs		H3	28pcs	 FLAT WASHER BIG
SHORT BRACE	P4	2pcs		H4	6pcs	 FLAT WASHER SMALL
CURVY BRACE	P5	2pcs		H5	1pcs	 ALLEN KEY
CONNECTOR BLOCK	P6	2pcs		H6	4pc	 ADJUSTABLE GLIDE

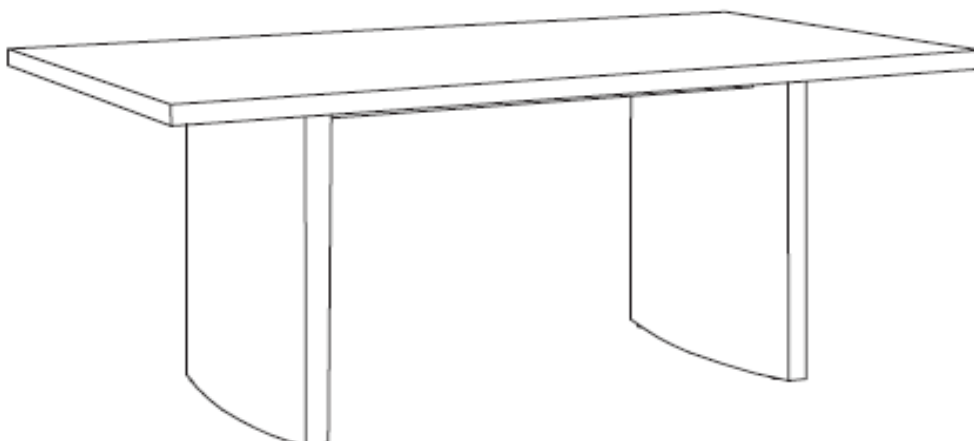

COMPLETE ASSEMBLY



ASSEMBLY INSTRUCTIONS

RECTANGULAR DINING TABLE



STEP 1

H1 x 12	
M6 x 35mm	
H2 x 12	
H3 x 12	

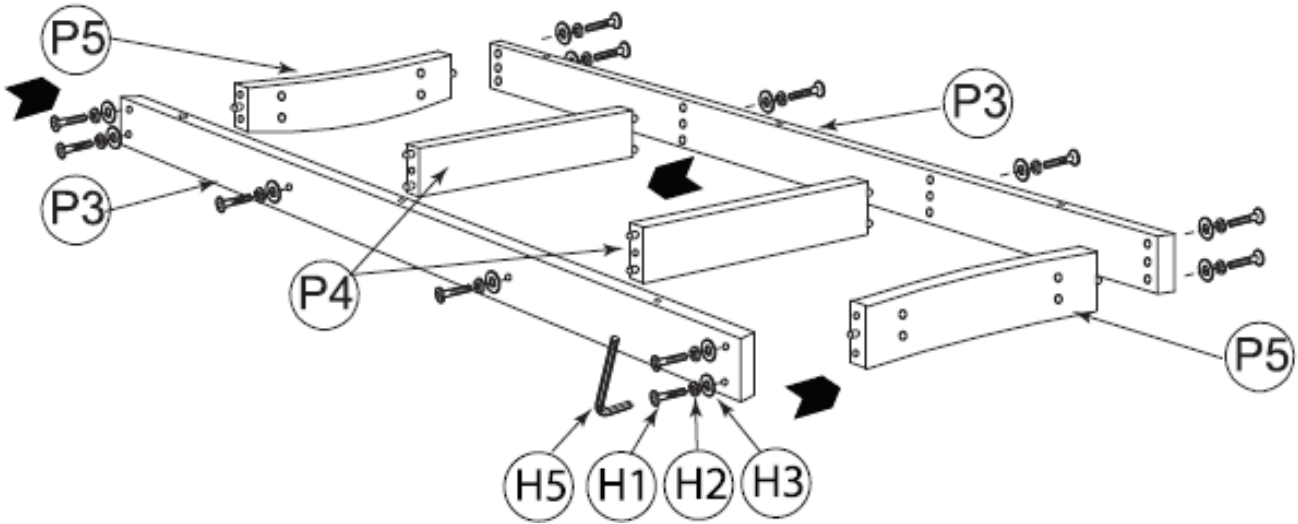
Assemble the Support frame: which consist of the Long braces (P3),the Short braces (P4) & the Curvy braces (P5). Use the Bolt (H1) together with the Spring Washer (H2) & the Flat Washer (H3) to connect & fit all the parts.Tighten the bolts using the Allen Key (H5) .





STEP 2

H1 x 6	
M6 x 35mm	
H4 x 6	

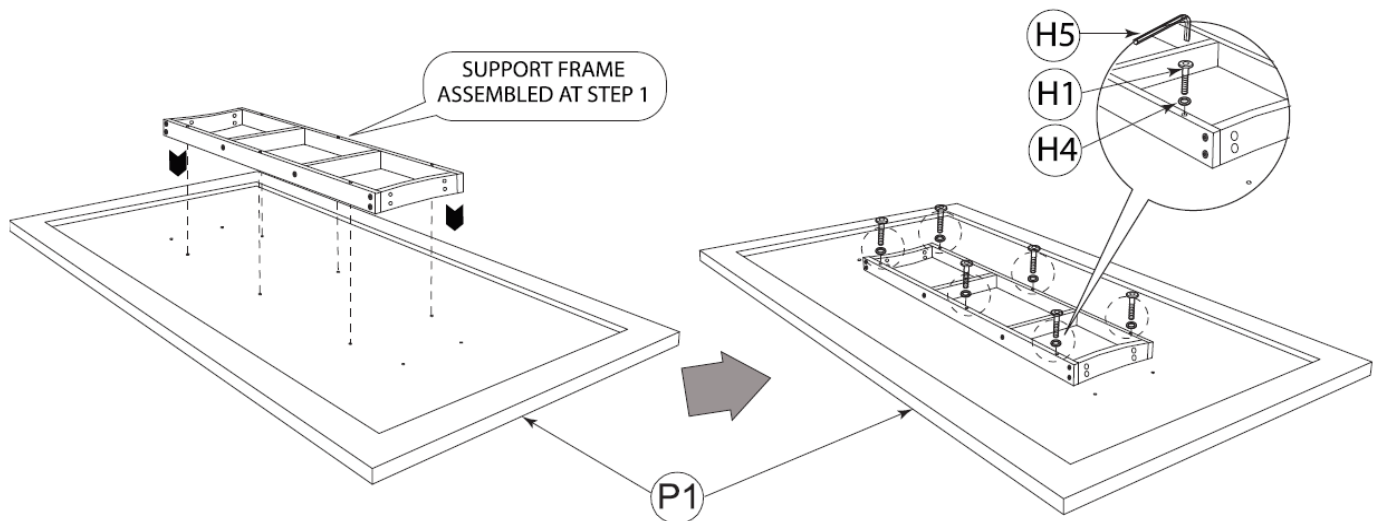
Place the Table top (P1) upside down on a clean and soft surface. Attach the new Support frame which was previously assembled in STEP 1 . Align the bolt (H1) fit with small washer (H4), and tighten it using the Allen key (H5) to attach and secure the parts .





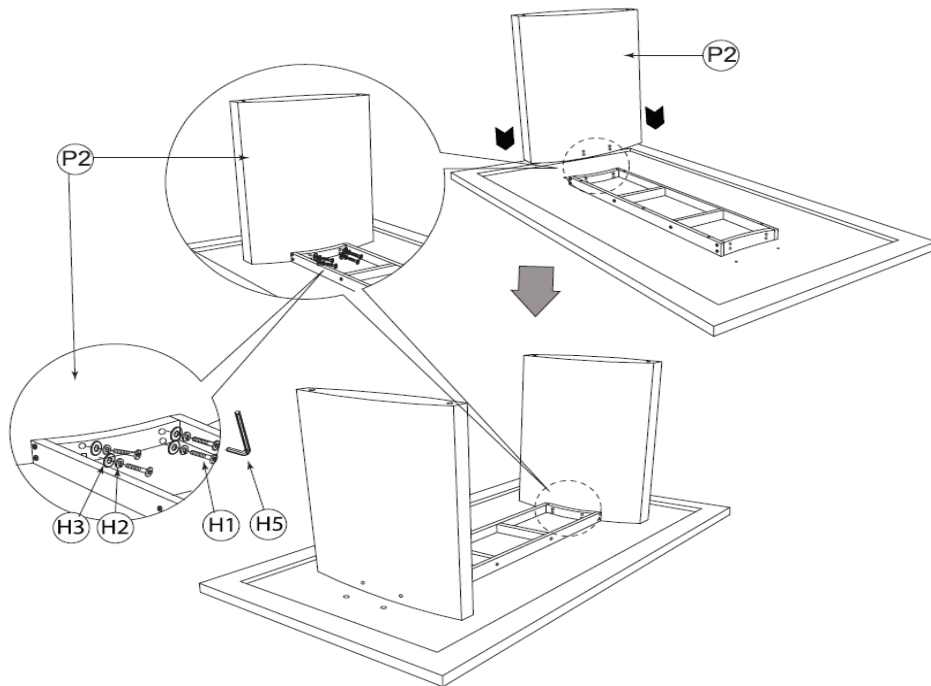

STEP 3

H1 x 8	 M6 x 35mm
H2 x 8	
H3 x 8	

Assemble the Legs (P2) to the Support frame. Align the Bolt (H1) together with the Spring Washer (H2) & the Flat Washer (H3). Tighten the bolt using the Allen key (H5) to secure the first leg. Repeat the same process to attach the other Leg.



STEP 4

H1 x 8	 M6 x 35mm
H2 x 8	
H3 x 8	
H6 x 4	

Mount the Connector block (P6) to strengthen the table legs (P2) to the Table top (P1) and use the Bolt (H1) together with the Spring washer (H2) & Flat washer (H3) to secure the connector to the leg. Repeat this step on the other leg. Tighten all the Bolts using the Allen key (H5).

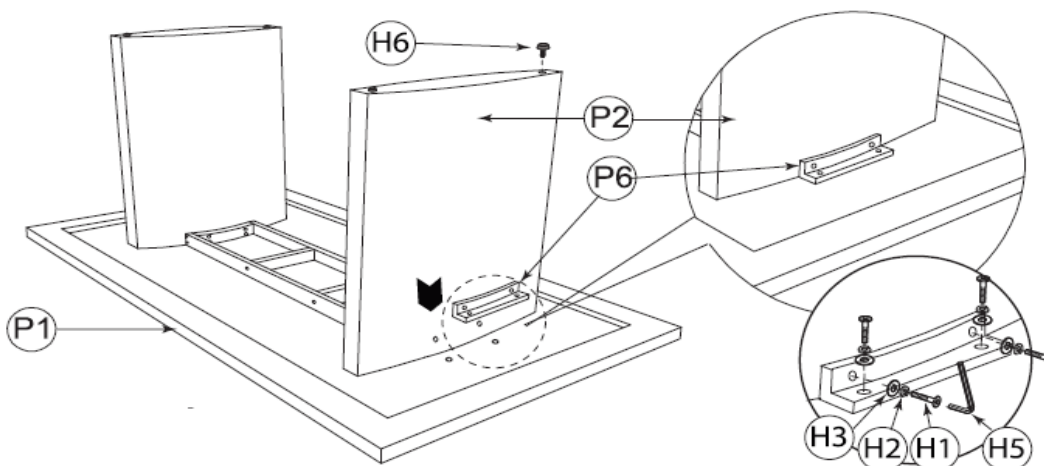

Before you turn the table upright, install the Adjustable Glides (H6) which will help adjust the table height and balance.

CAREFULLY TURN TABLE UPRIGHT WITH THE HELP OF TWO OR MORE PEOPLE.

CARE AND MAINTENANCE

- SAFETY** - To avoid any risk of suffocation to children or animals, dispose off the plastic bags immediately.
- CLEANING** - Clean with damp cloth and mild detergent. Do not use bleach or abrasive products.
- FITTINGS** - Tighten bolts and nuts from time to time to ensure all parts of product are securely fitted.