

Assembly Instructions

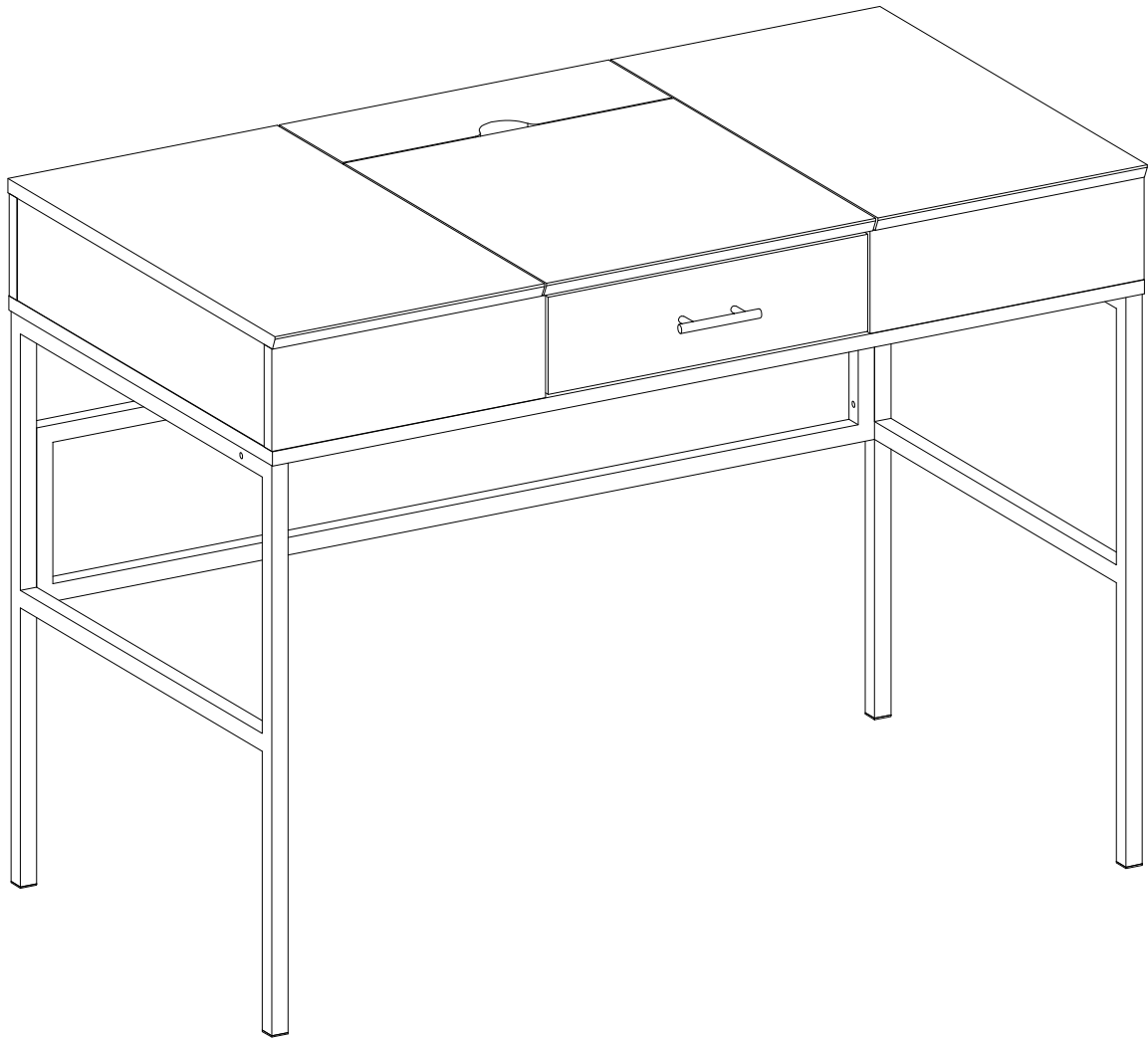

General Assembly Guidelines

- I. Ensure that all parts and hardware are available before beginning assembly.
- II. Follow each step carefully to ensure the proper assembly of this product.
- III. Two people are recommended for ease in the assembly of this product.
- IV. The three main types of hardware used to assemble this product are : wood dowels , screws and bolts.
- V. The provided glue is to secure wood dowels in place . When first inserting dowels , locate the appropriate hole for the dowel , place a small amount of glue in the hole and insert the dowel . Wipe away excess glue immediately.

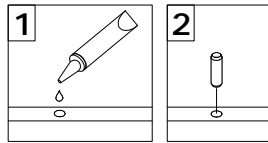

In future assembly steps when dowels are necessary to attach assembly parts together , place a small amount of glue on the end of the dowel before attaching parts together . Wipe away excess glue immediately.

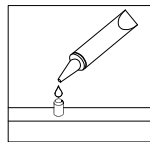

- VI. A Phillips head screwdriver is required for the assembly of this product .

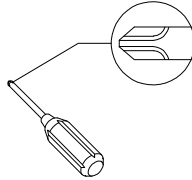

- VII. Power tools should not be used to assemble this product .

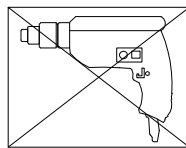

- VIII. Concealed hinges are three-way adjustable.

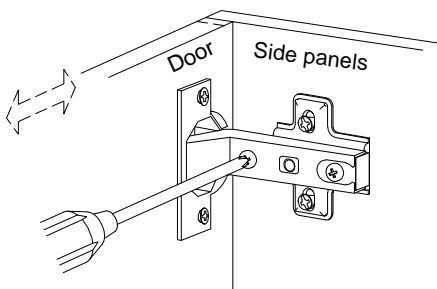

Horizontal
by screw adjustment

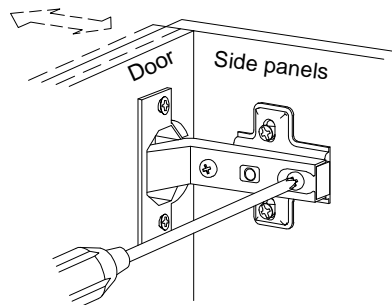

In-and-Out
by loosening the hinge-arm
mounting screw or via cam
adjustment

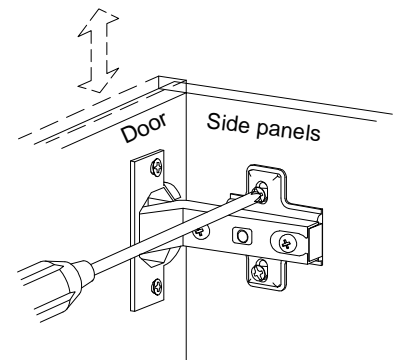





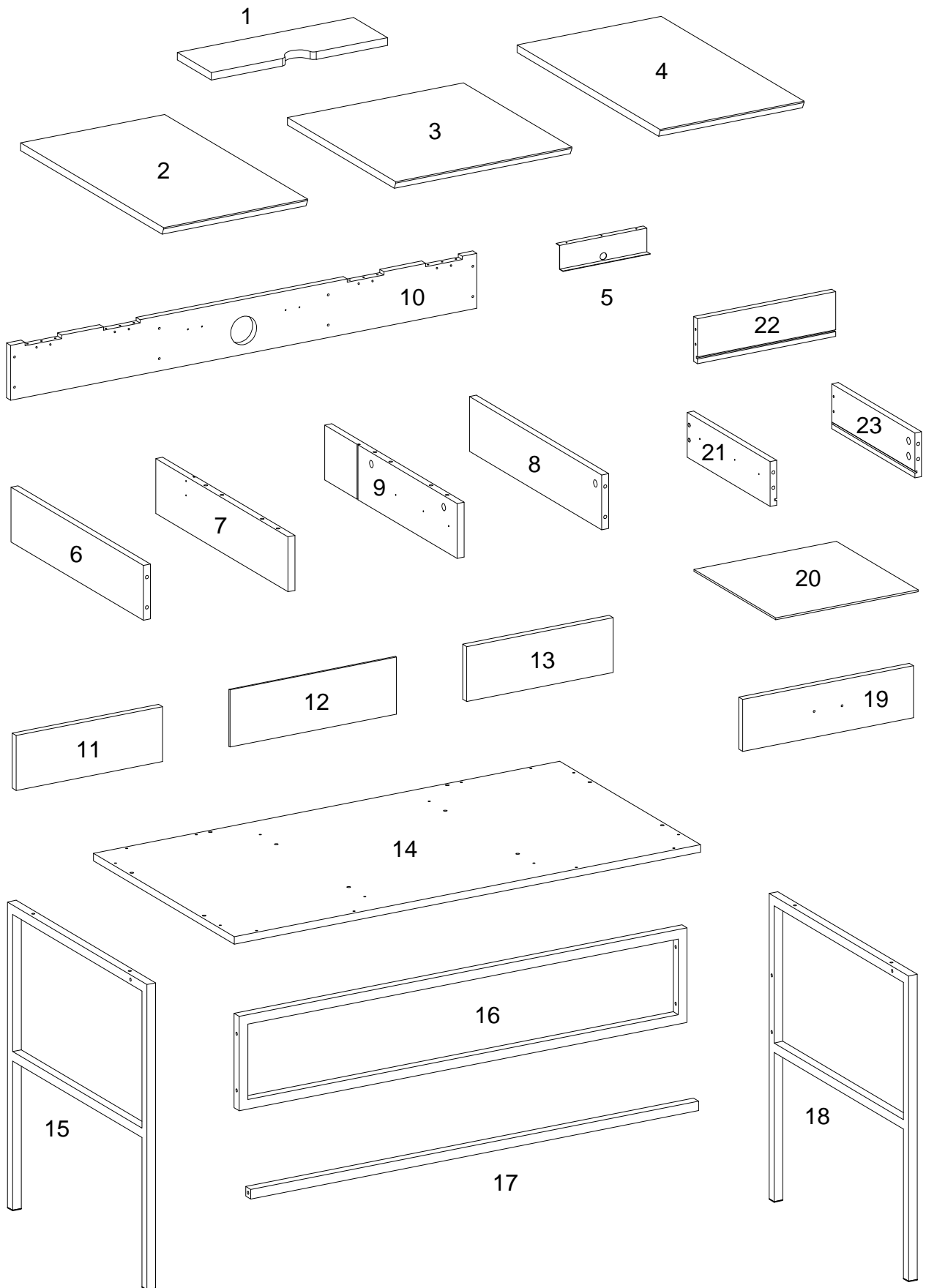









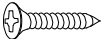

Vertical
Via slots in the mounting
plate or via cam adjustment

Parts List



Hardware List

A		Ø8x30mm	Wooden dowel	16	pcs
B		Ø6x35mm	Cam bolt	10	pcs
C		Ø15x11mm	Cam lock	10	pcs
D		Ø30mm	Sticker	10	pcs
E		M6x30mm	Bolt	10	pcs
F		M 4	Hex key	1	pc
G			Europe hinge	2	pcs
H		Ø4x12mm	Screw	8	pcs
J		Ø4x38mm	Screw	28	pcs
K			Handle	1	pc
L		M4x22mm	Screw	2	pcs
M		Ø4x12mm	Screw	55	pcs
N			Hinge	4	pcs
P			Hinge	1	pc
Q			Hinge	1	pc
R			Glue tube	1	pc
S			Drawer slider	1	set

*Note: This piece comes preassembled for shipping purposes and must be disassembled to complete the desk assembly.

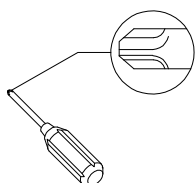

Philips head screwdriver required for assembly
(not included)

*The hardware quantities listed above are required for proper assembly.
Some extra hardware may also have been included.*

Step 1

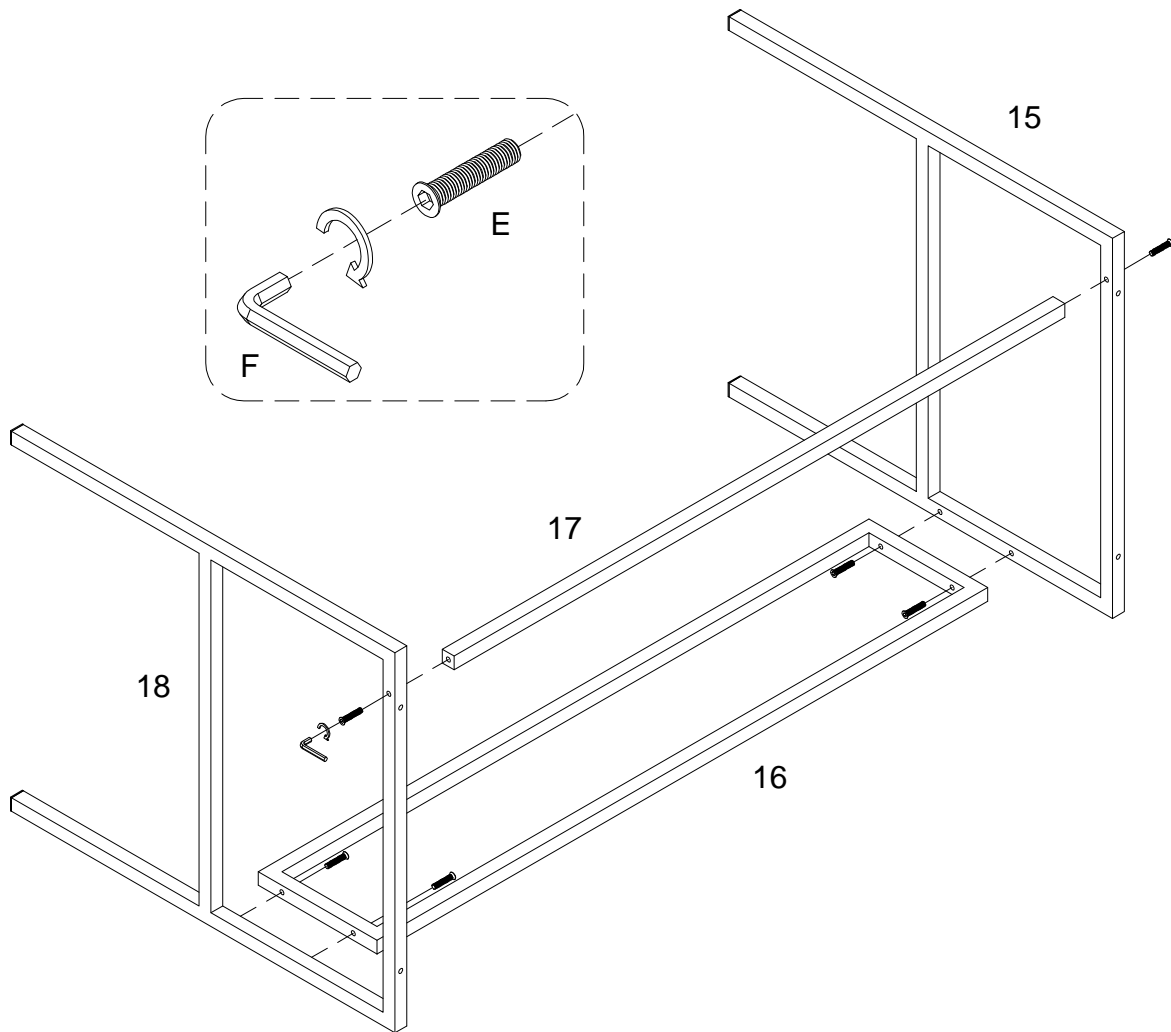

Using bolt (E) attach parts (15,18) to parts (16,17) with Hex key (F) as per diagram.
Note: Do not fully tighten all the bolts .

Step 2

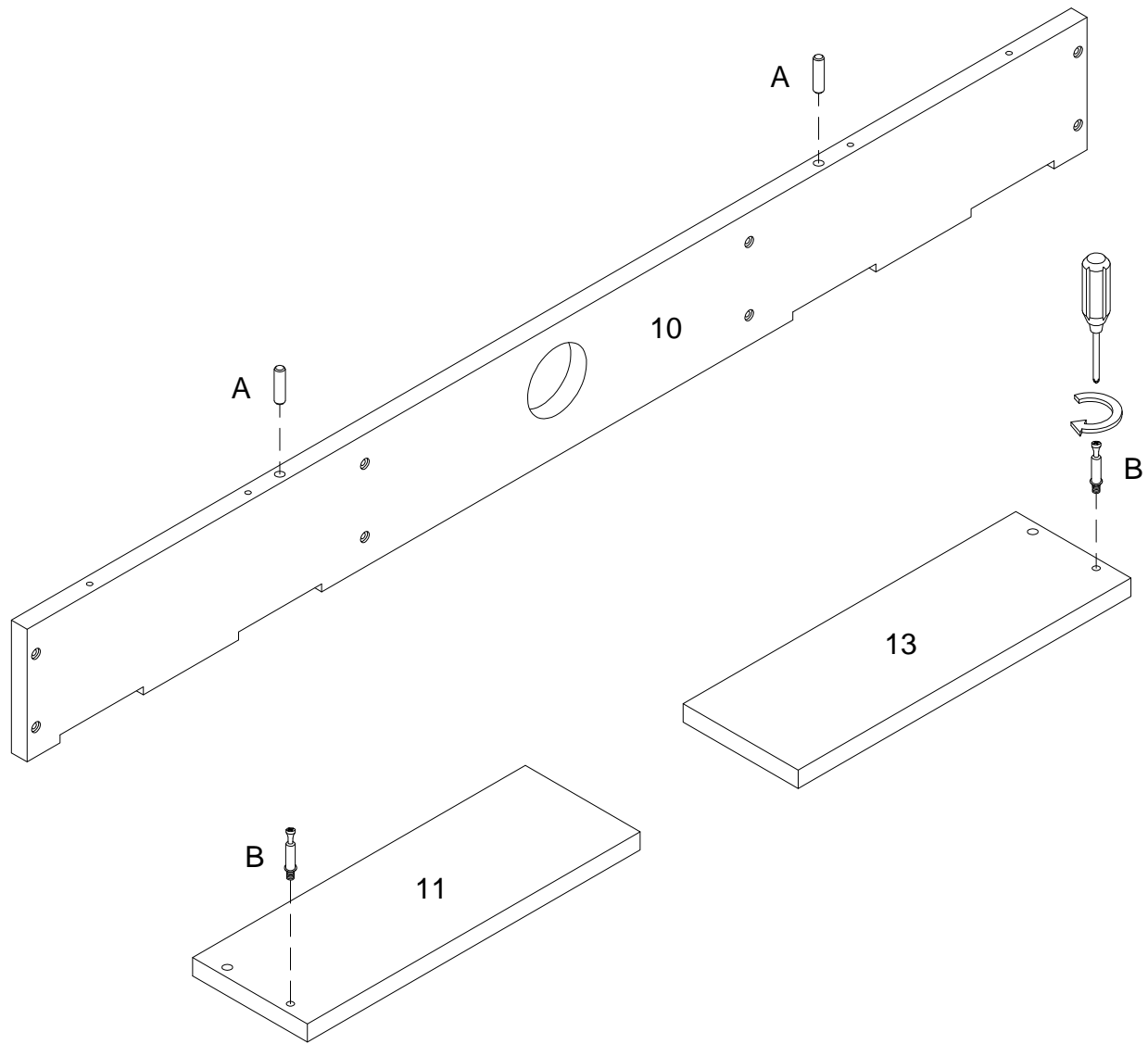

Insert wooden dowel (A) into part (10) ,then secure cam bolt (B) into parts (11,13) with Philips head screwdriver as per diagram.

Step 3

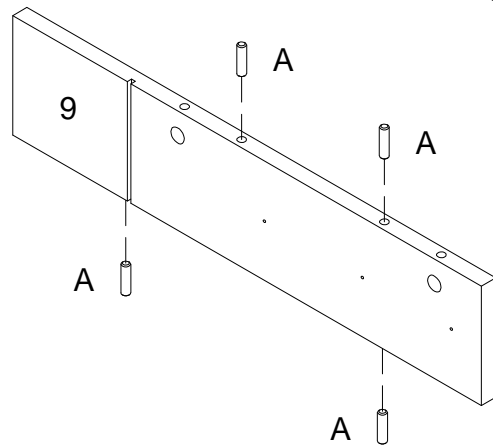
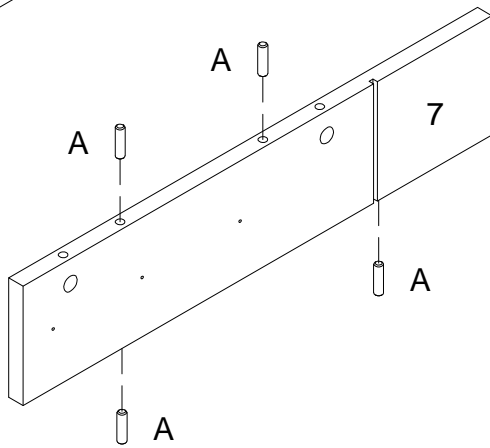
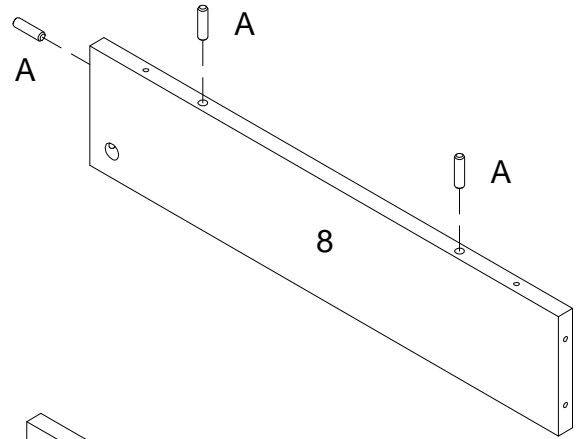
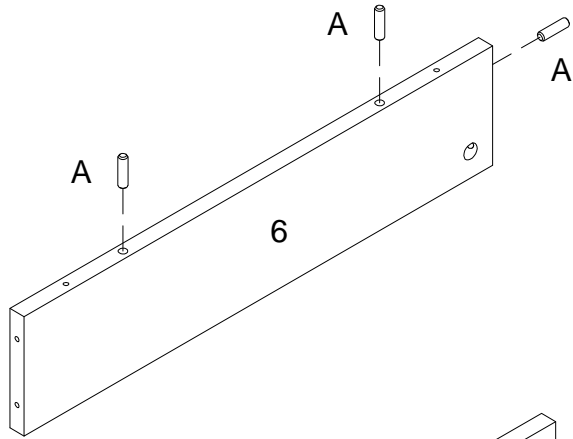

Insert wooden dowel (A) into part (6,7,8,9) as per diagram.

Step 4

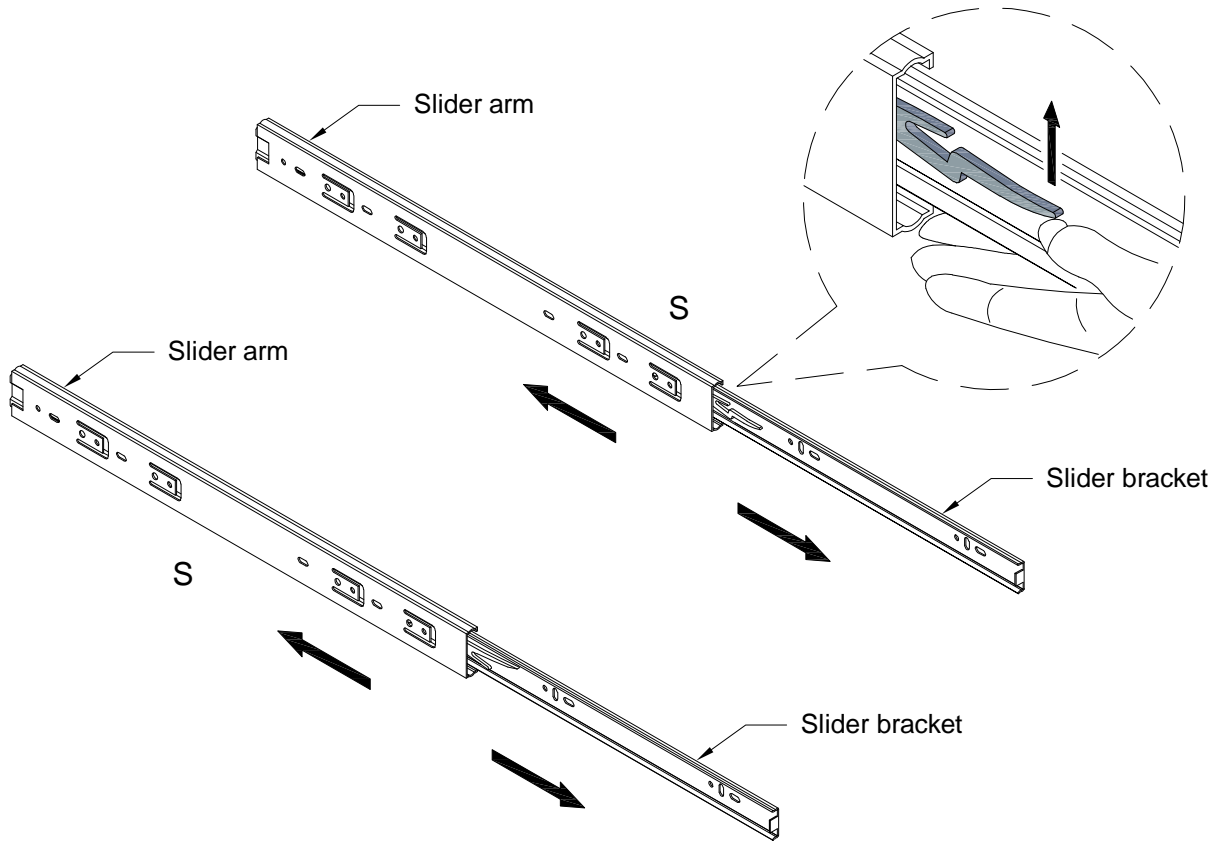

Pick up the slider arm (S) and separate the slide Runner for the following Steps. Extend the Slide Runner all the way forward, press the plastic release lever of the slider arm up and pull the Slide Runner Complete out .

Step 5

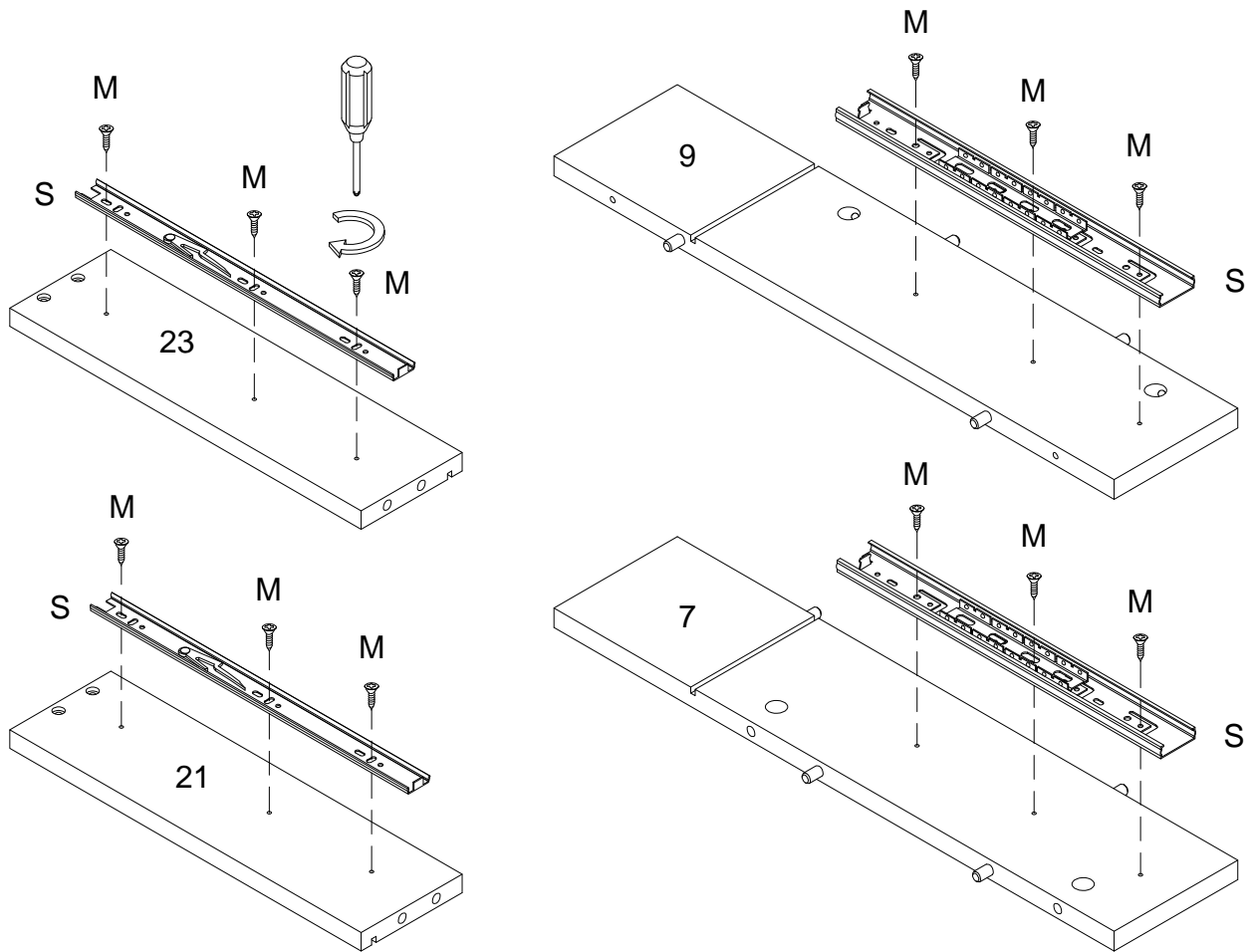

Using screw (M) attach slider (S) to parts (7,9,21,23) with Philips head screwdriver as per diagram.

Step 6

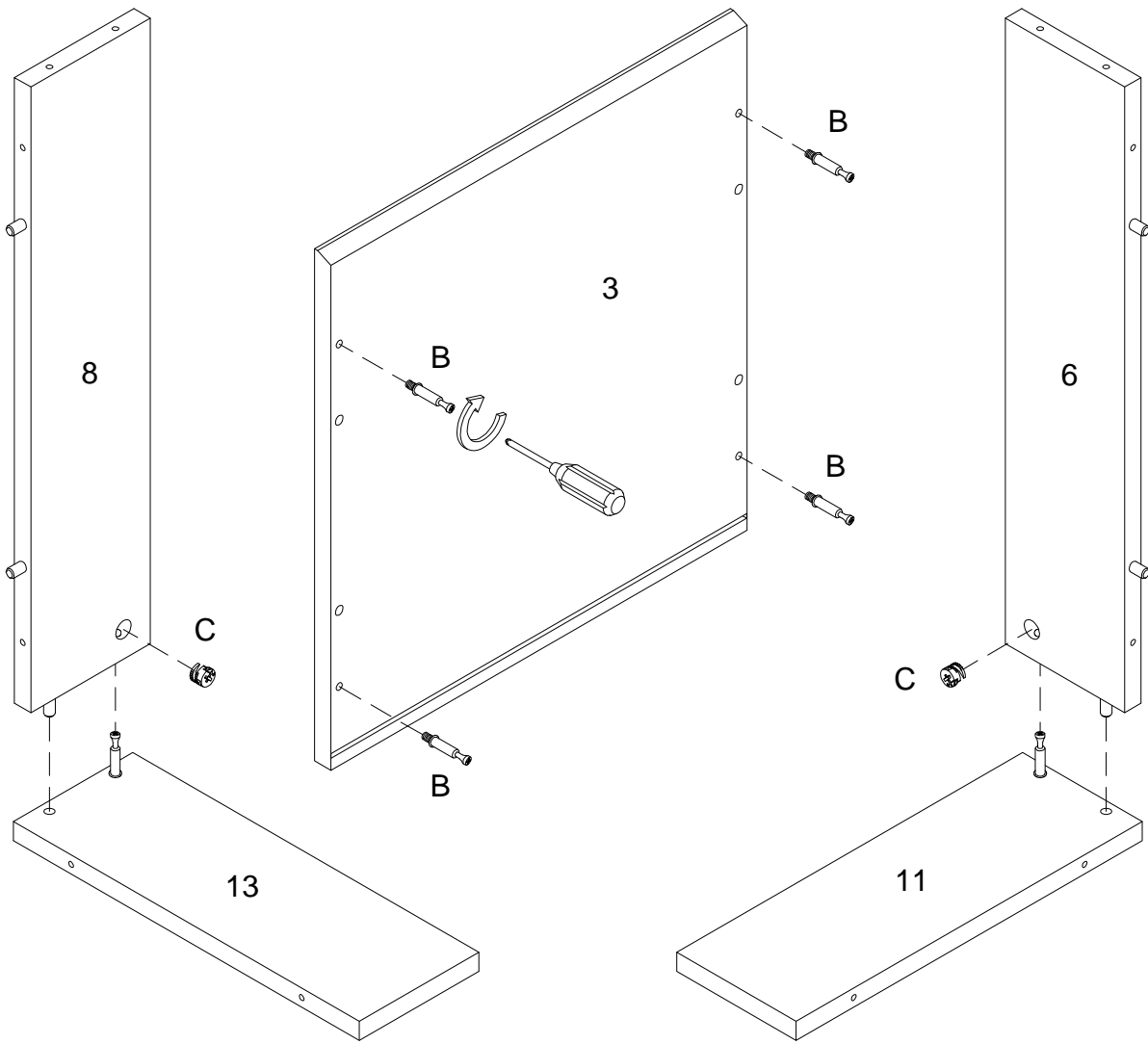
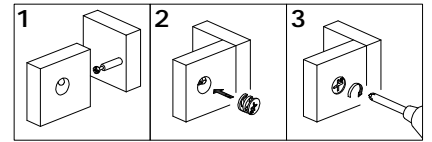

secure cam bolt (B) into part (3) , then using cam lock (C) secure part (6) to part (11) ,part (8) to part (13) with Philips head screwdriver as per diagram.

Step 7

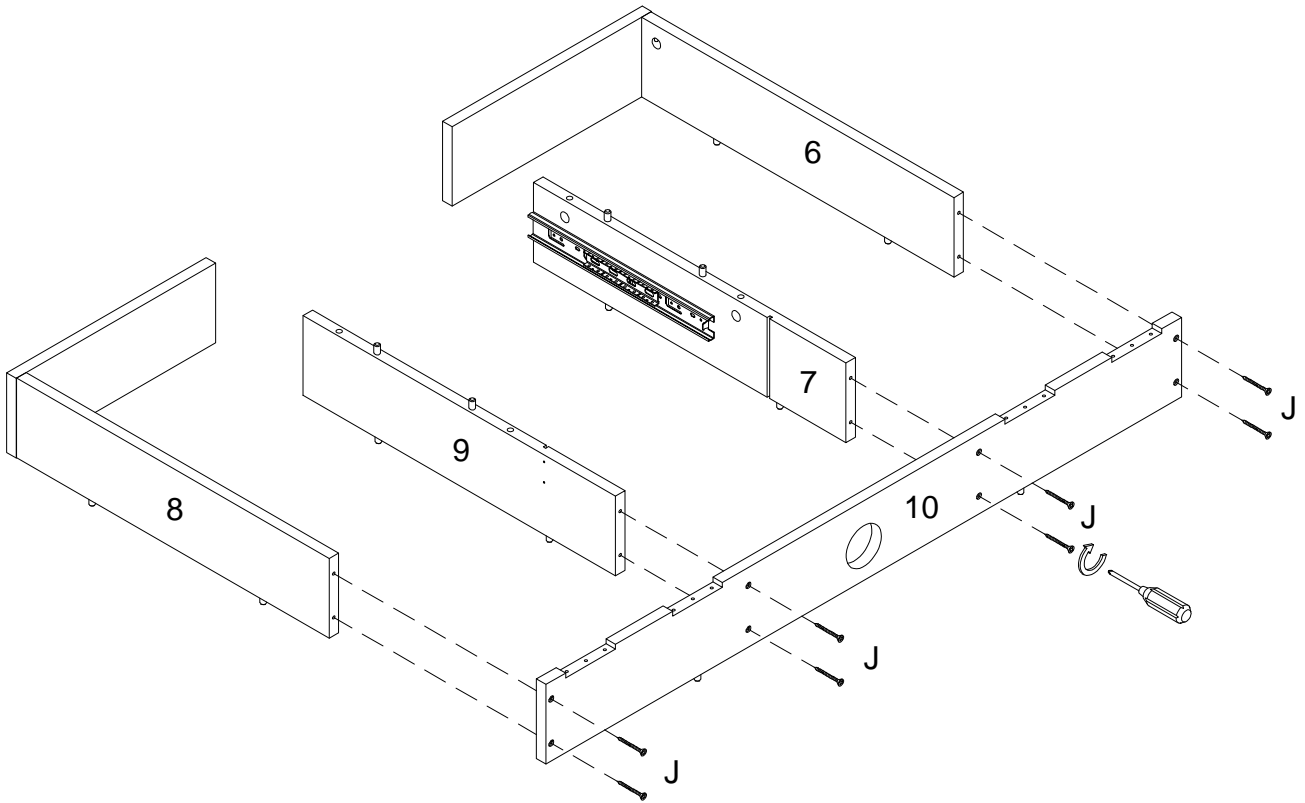

Using screw (J) attach part (10) into parts (6,7,8,9) with Philips head screwdriver as per diagram.

Step 8

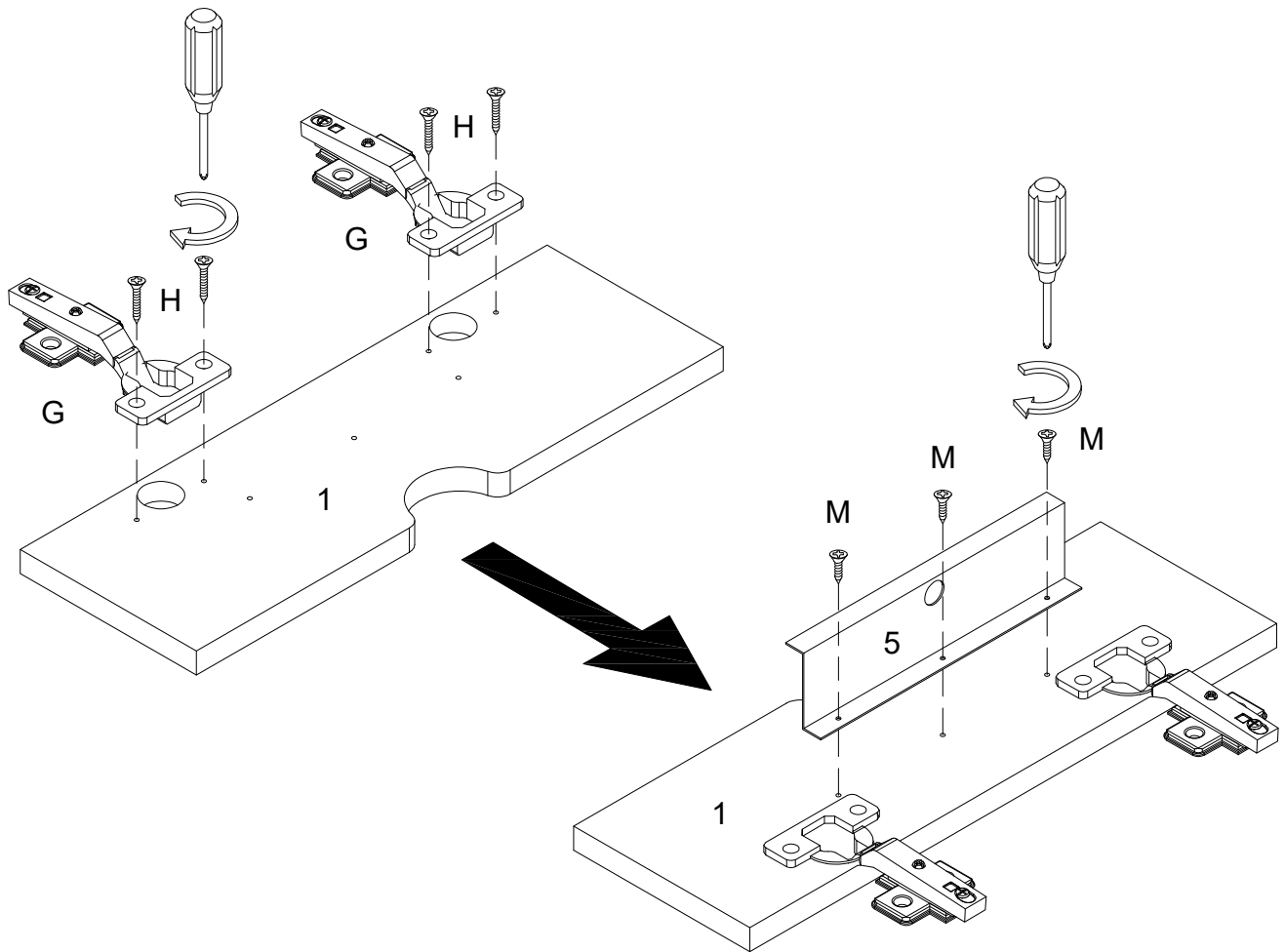

Using screw (H) attach Europe hinge (G) into part (1) , then using screw (M) attach part (5) to part (1) with Philips head screwdriver as per diagram.

Step 9

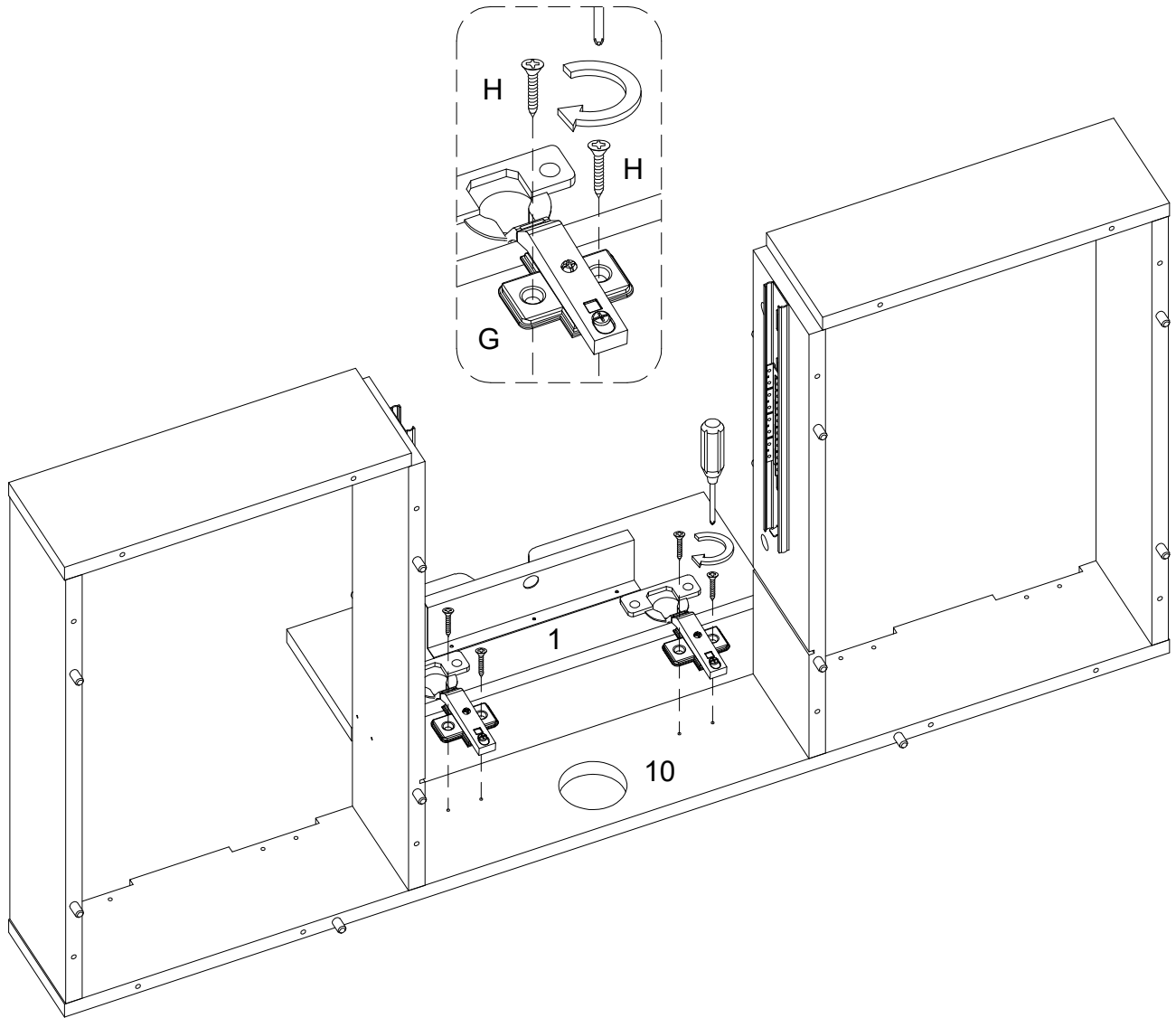

Using screw (H) attach Europe hinge (G) into part (10) with Philips head screwdriver as per diagram.

Step 10

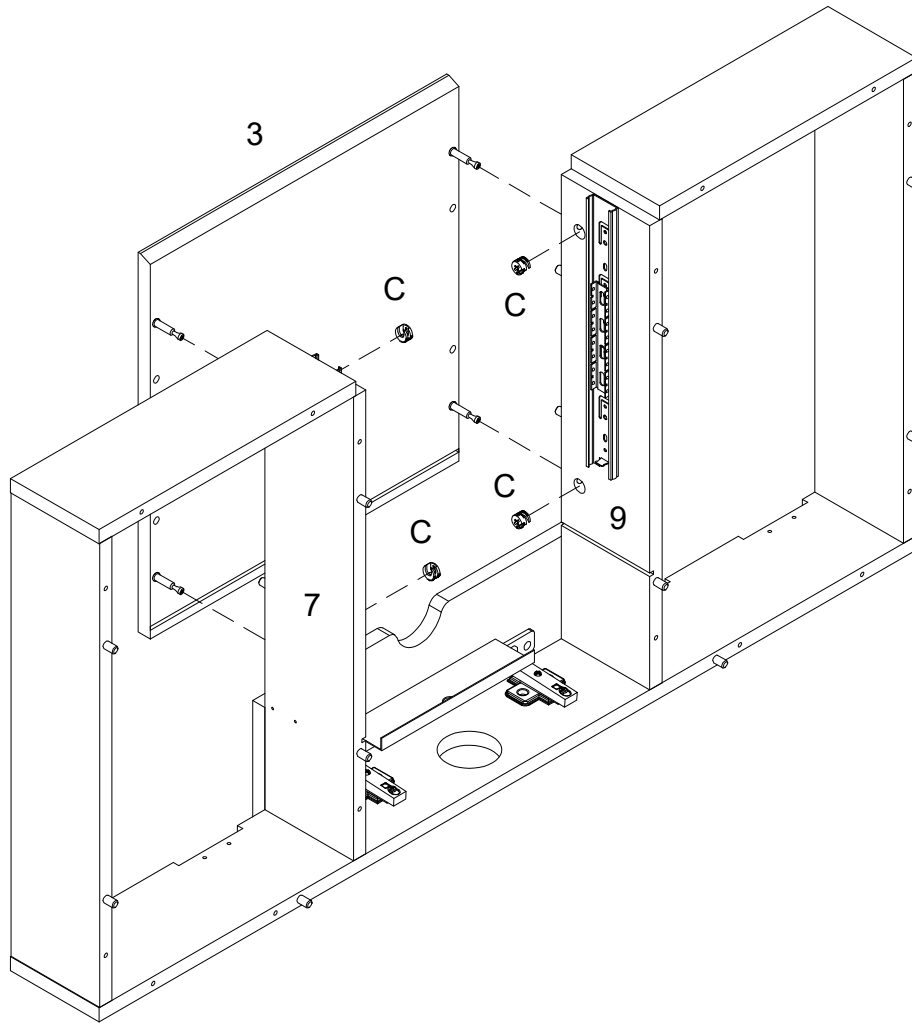
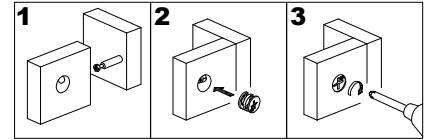

Using Cam lock (C) attach part (3) to parts (7,9) with Philips head screwdriver as per diagram. If necessary, refer to page 2 to adjust the gap between part (1) and part (3).

Step 11

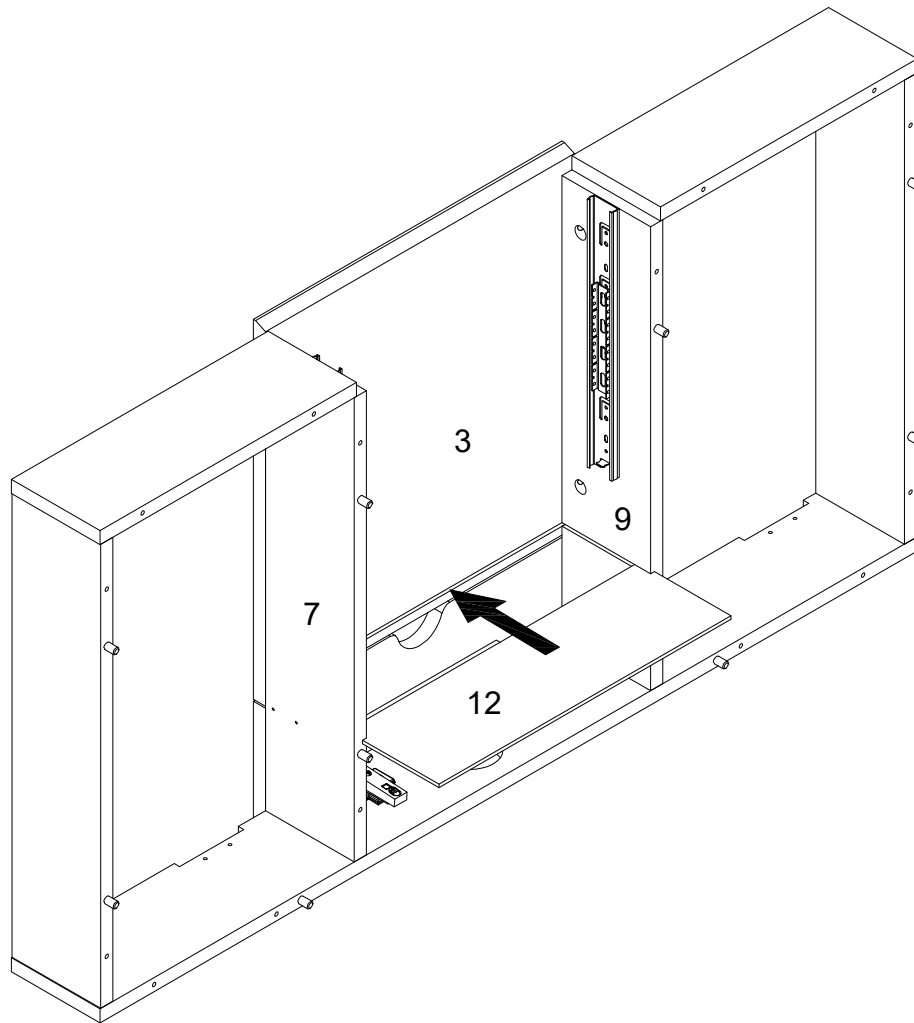

Put part (12) as per diagram.

Step 12

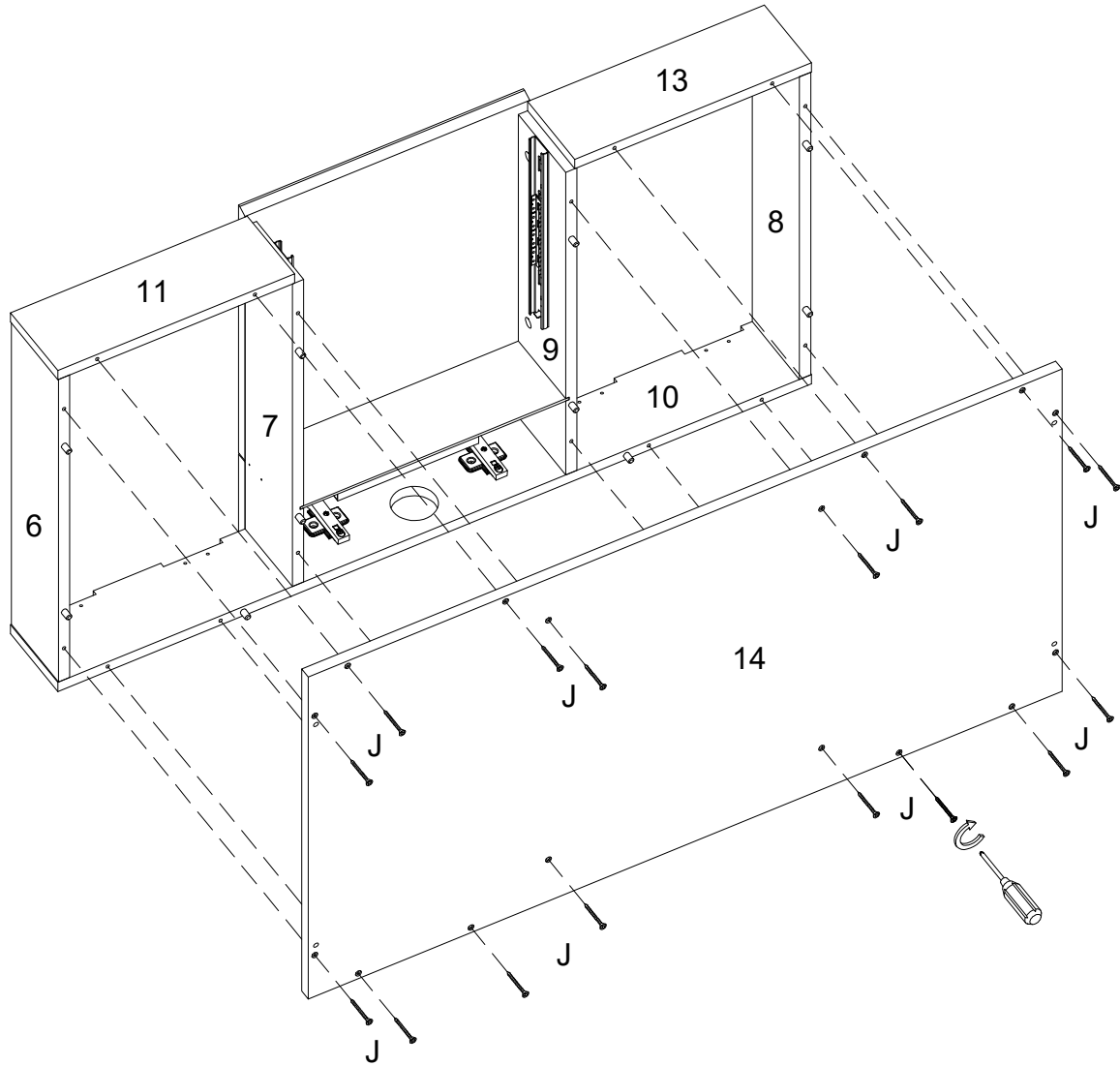

Using screw (J) attach part (14) to parts (6,7,8,9,10,11,13) with Philips head screwdriver as per diagram.

Step 13

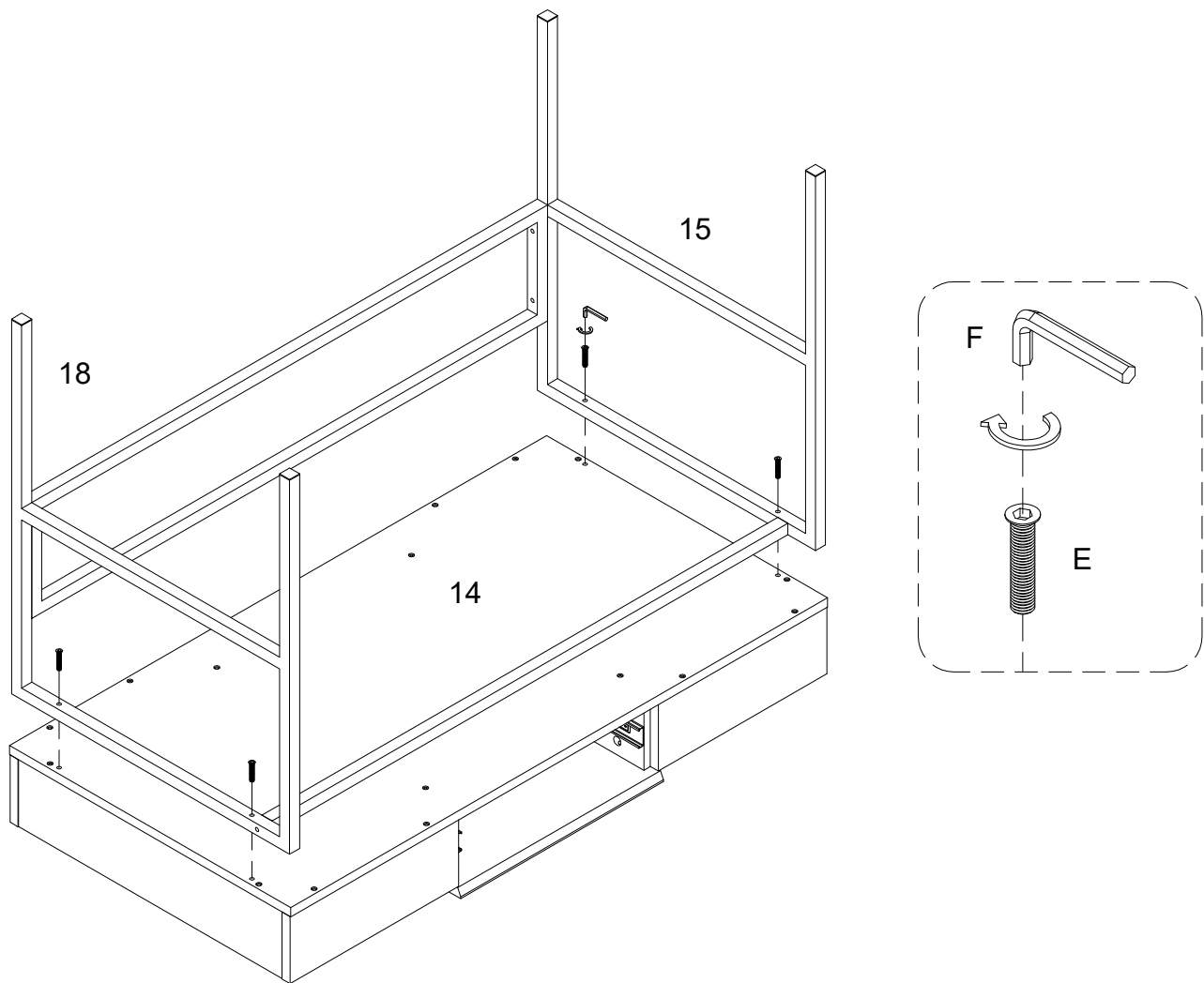

Using bolt (E) attach parts (15,18) into part (14) with Hex key (F) as per diagram.

Note : Fully tighten all the bolts .

Step 14

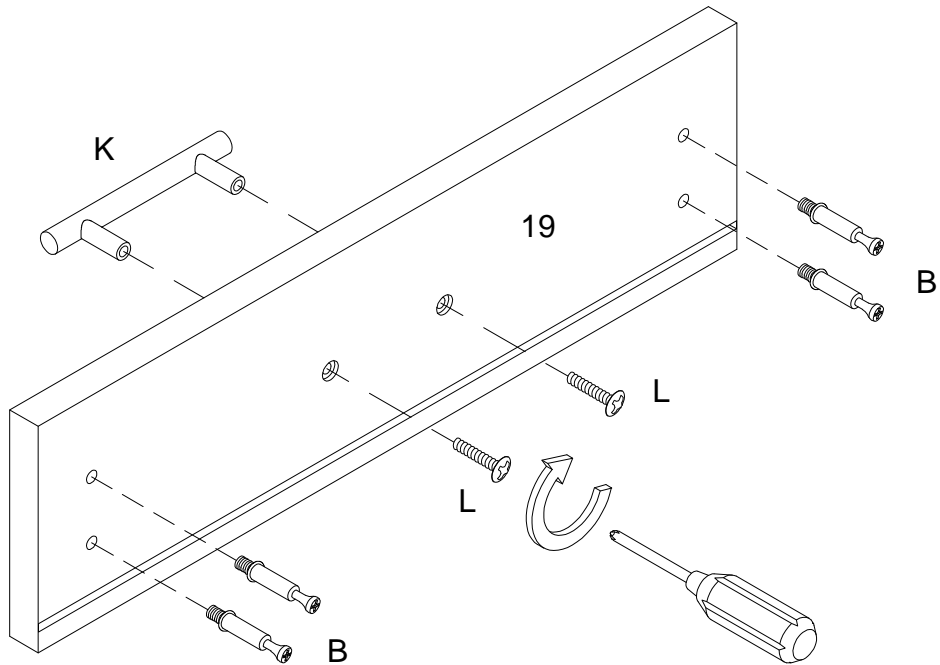

Using screw (L) attach handle (K) into part (19) ,and secure Cam bolt (B) into part (19) with Philips head screwdriver as per diagram.

Step 15

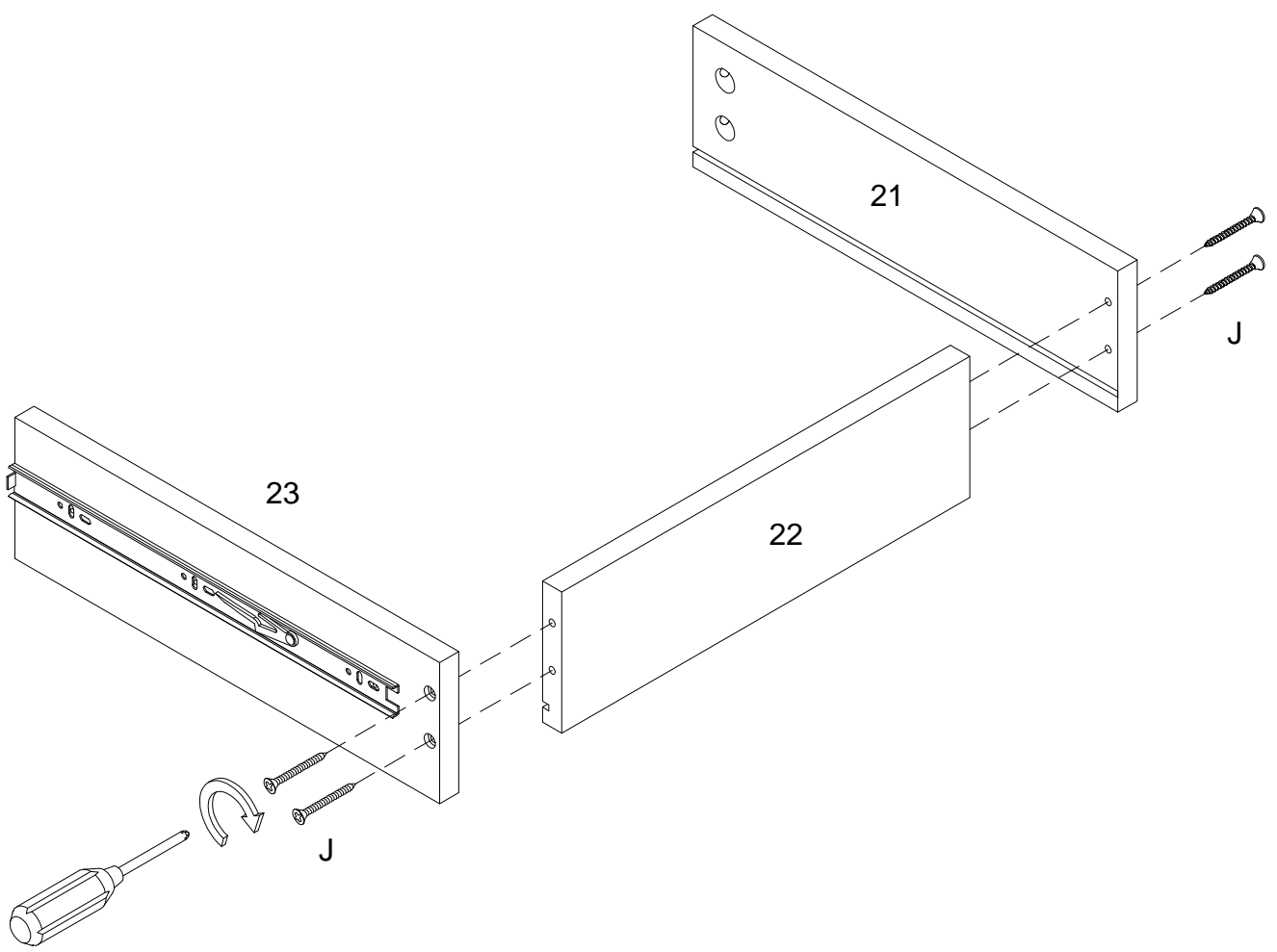

Using screw (J) attach part (21,23) to part (22) with Philips head screwdriver as per diagram.

Step 16

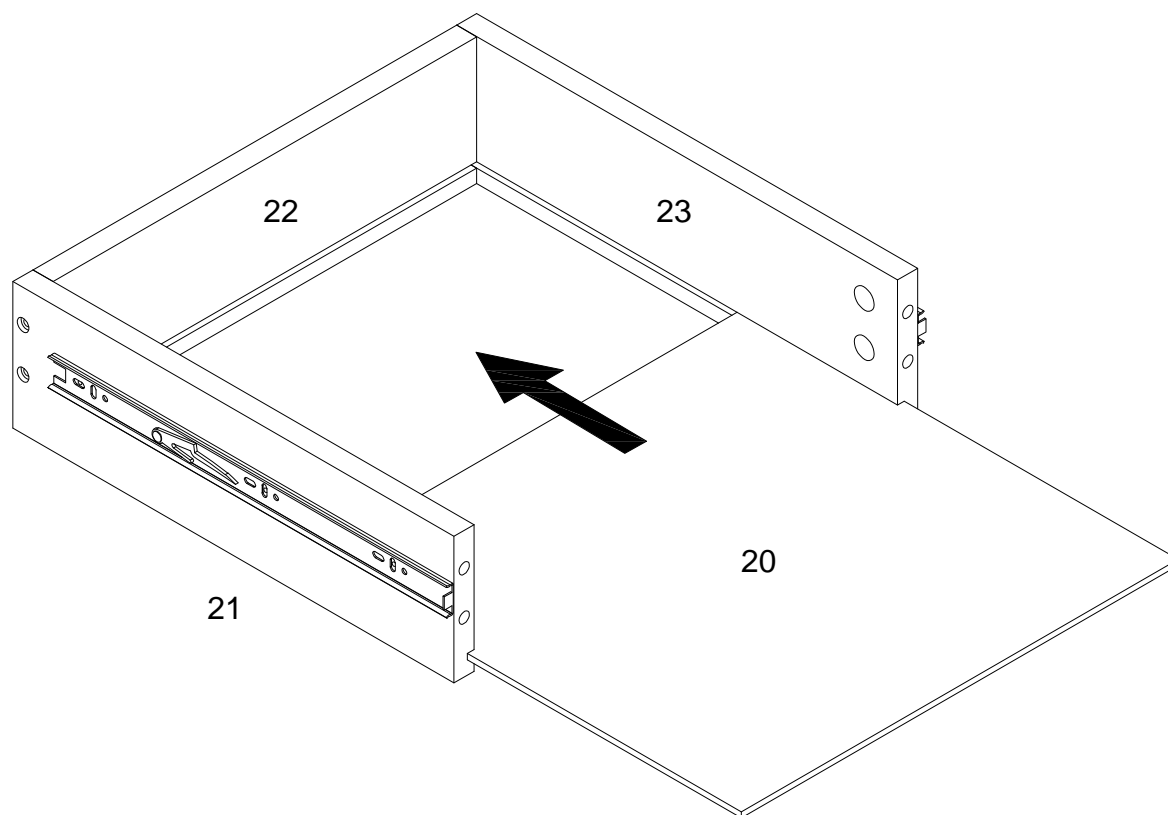

Put part (20) as per diagram.

Step 17

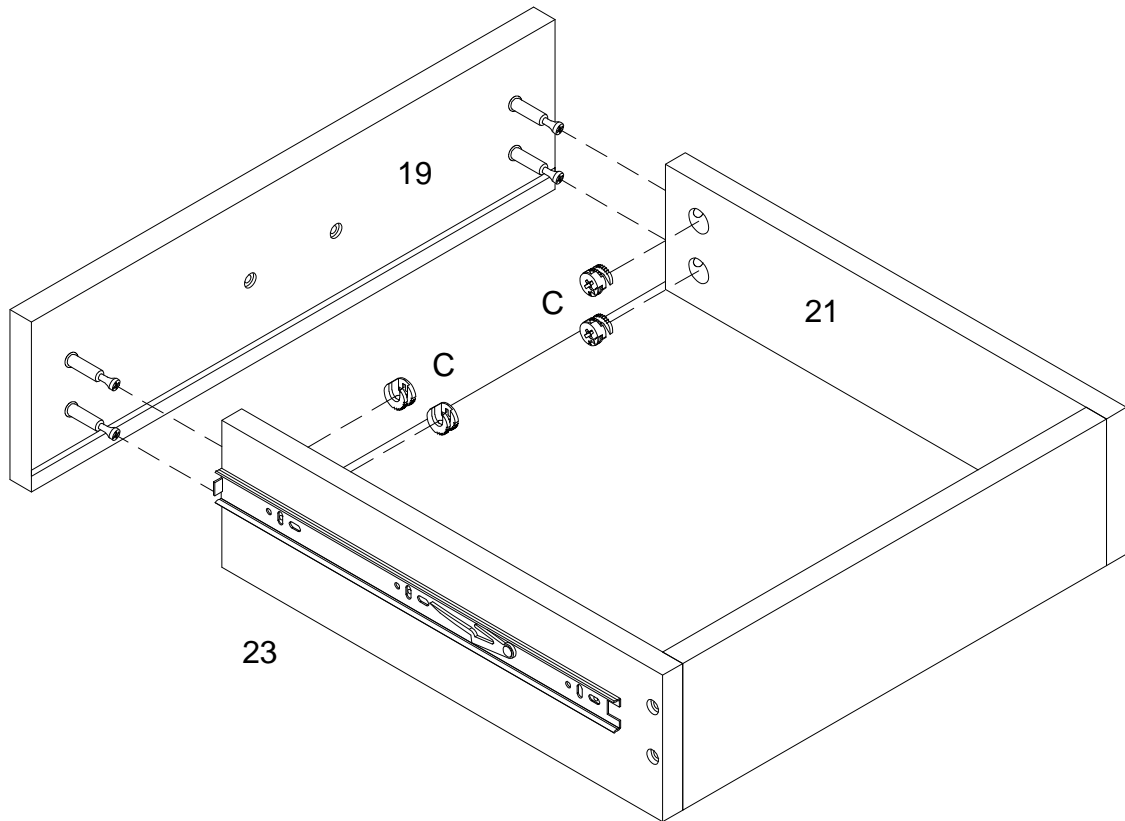
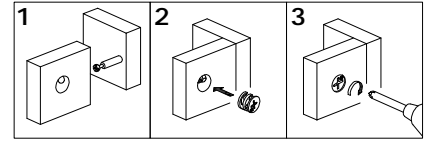

Using cam lock (C) secure part (19) to parts (21,23) with Philips head screwdriver as per diagram.

Step 18

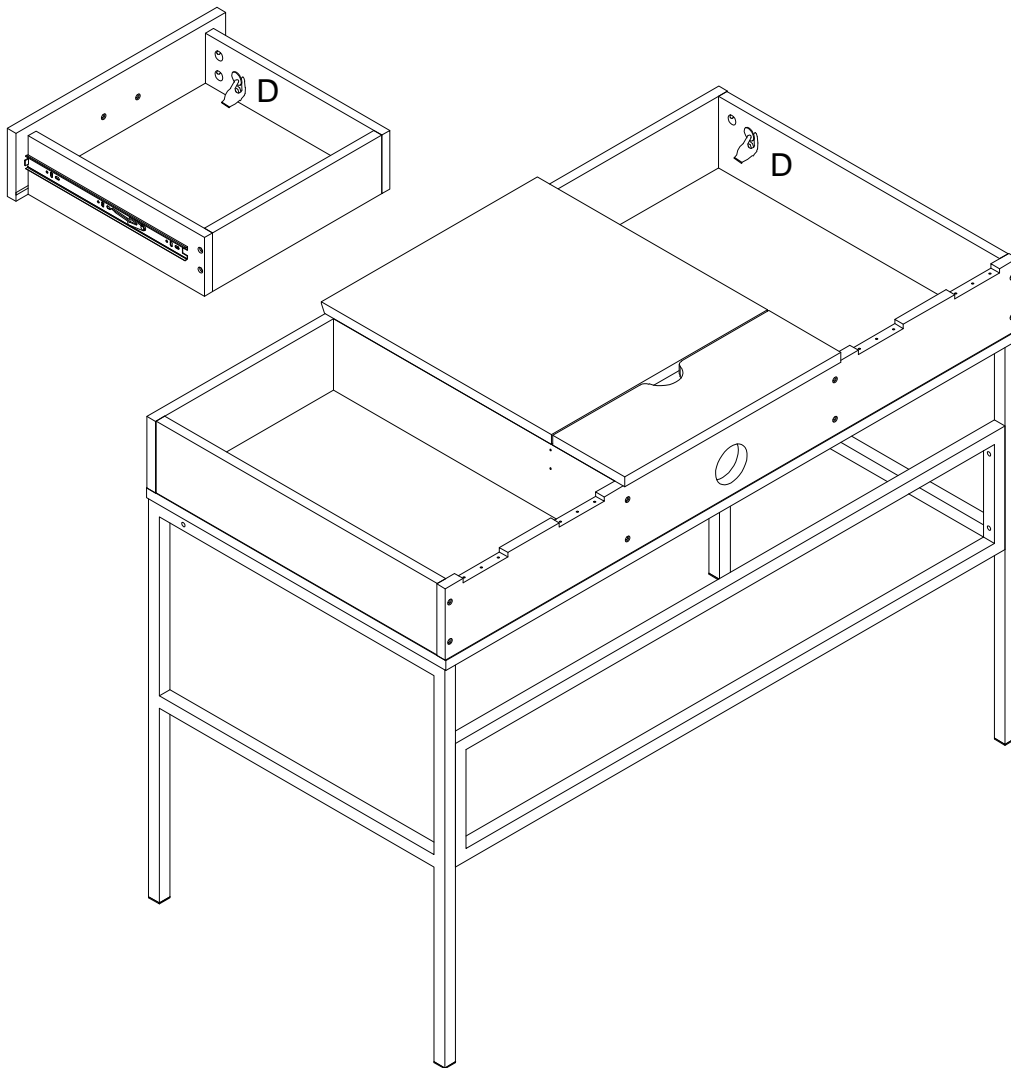

Place sticker (D) cover the holes as per diagram .

Step 19

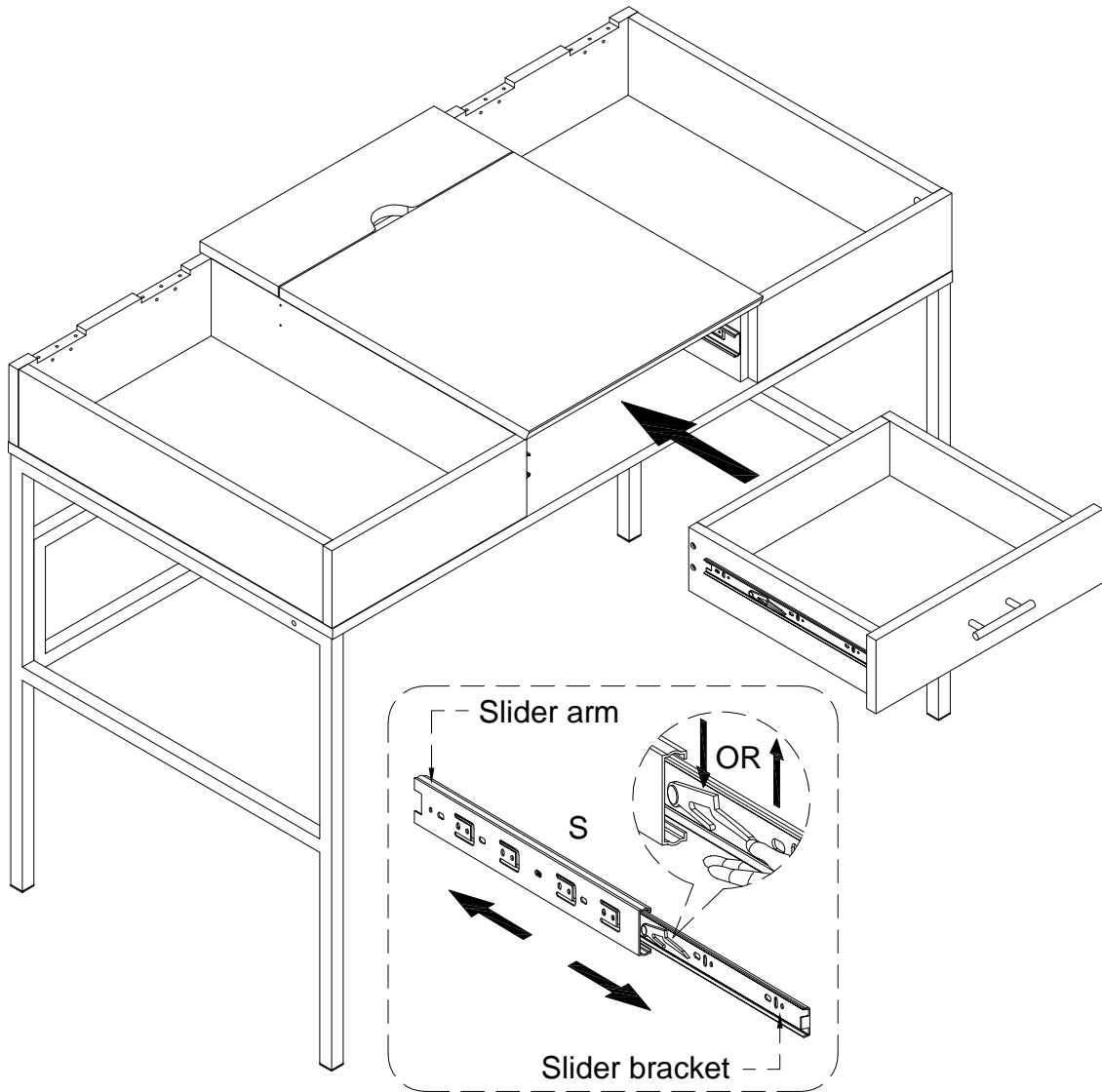

Insert the assembled drawers into the unit frame, extend the Ball Bearing Slide Tracks (S) on the pedestal Side Panel all the way forward. Then align the Slide Runners on the assembled drawers with the Slide Tracks and push the drawer carefully inside until it stops. Note : if the drawer does not go in smoothly, please take it out and repeat the step. If you need to remove the drawer, please pull the drawer all the way out, then push the plastic release lever of the ball bearing slide up on one side and down on the other side, and then pull it completely out.

Step 20

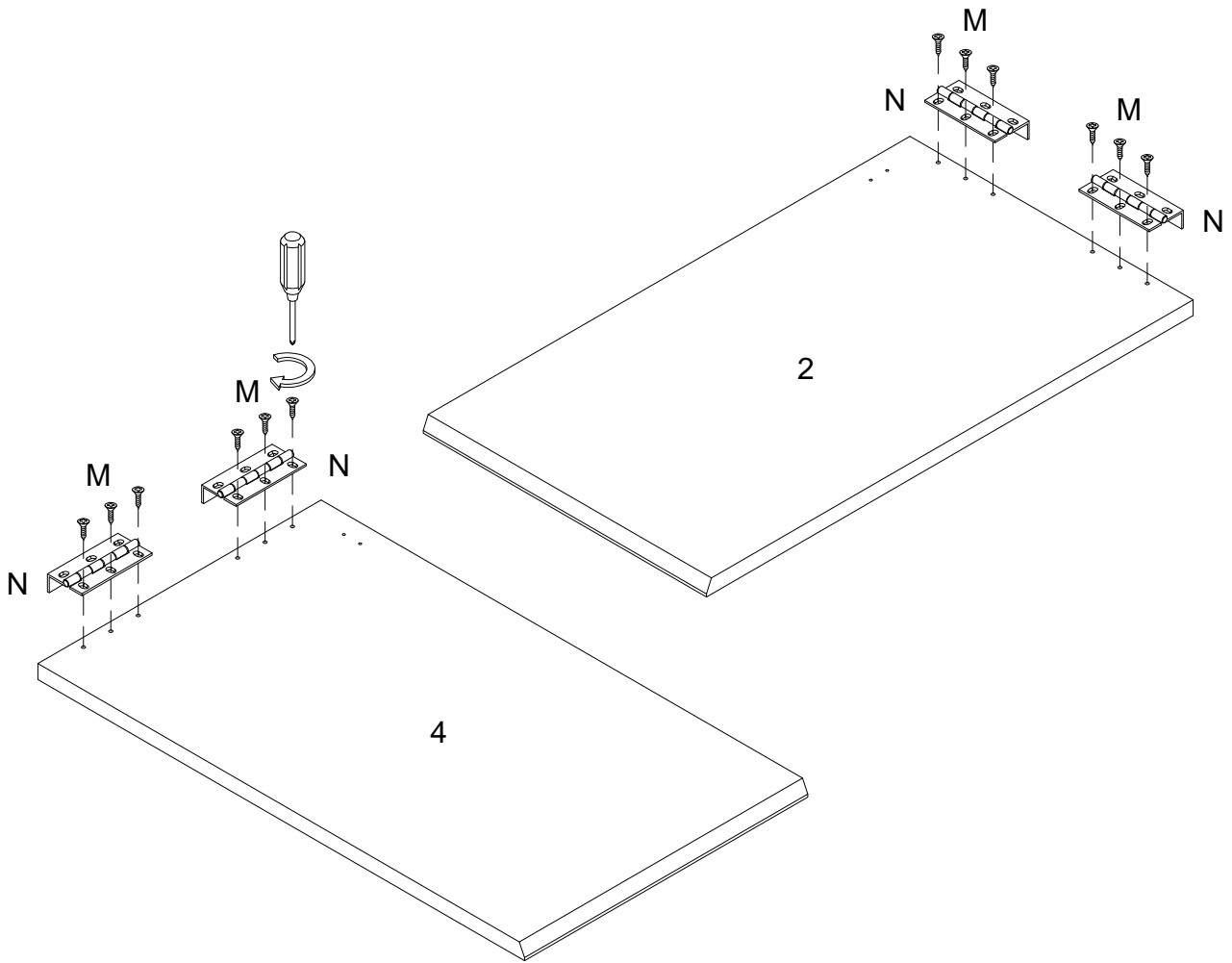

Using screw (M) attach hinge (N) to parts (2,4) with Philips head screwdriver as per diagram.

Step 21

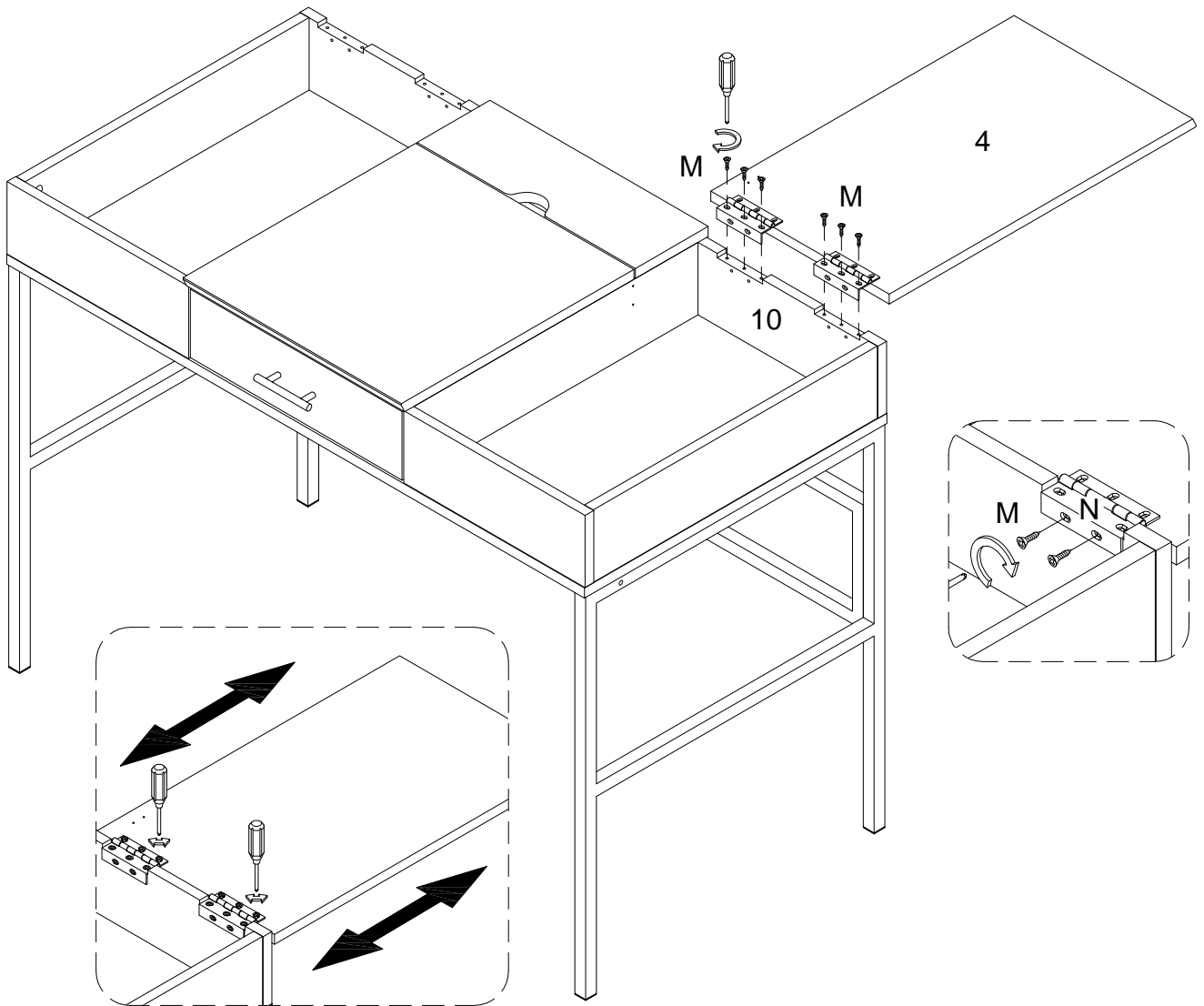

Using screw (M) attach hinge (N) to part (10) with Philips head screwdriver as per diagram.

Step 22

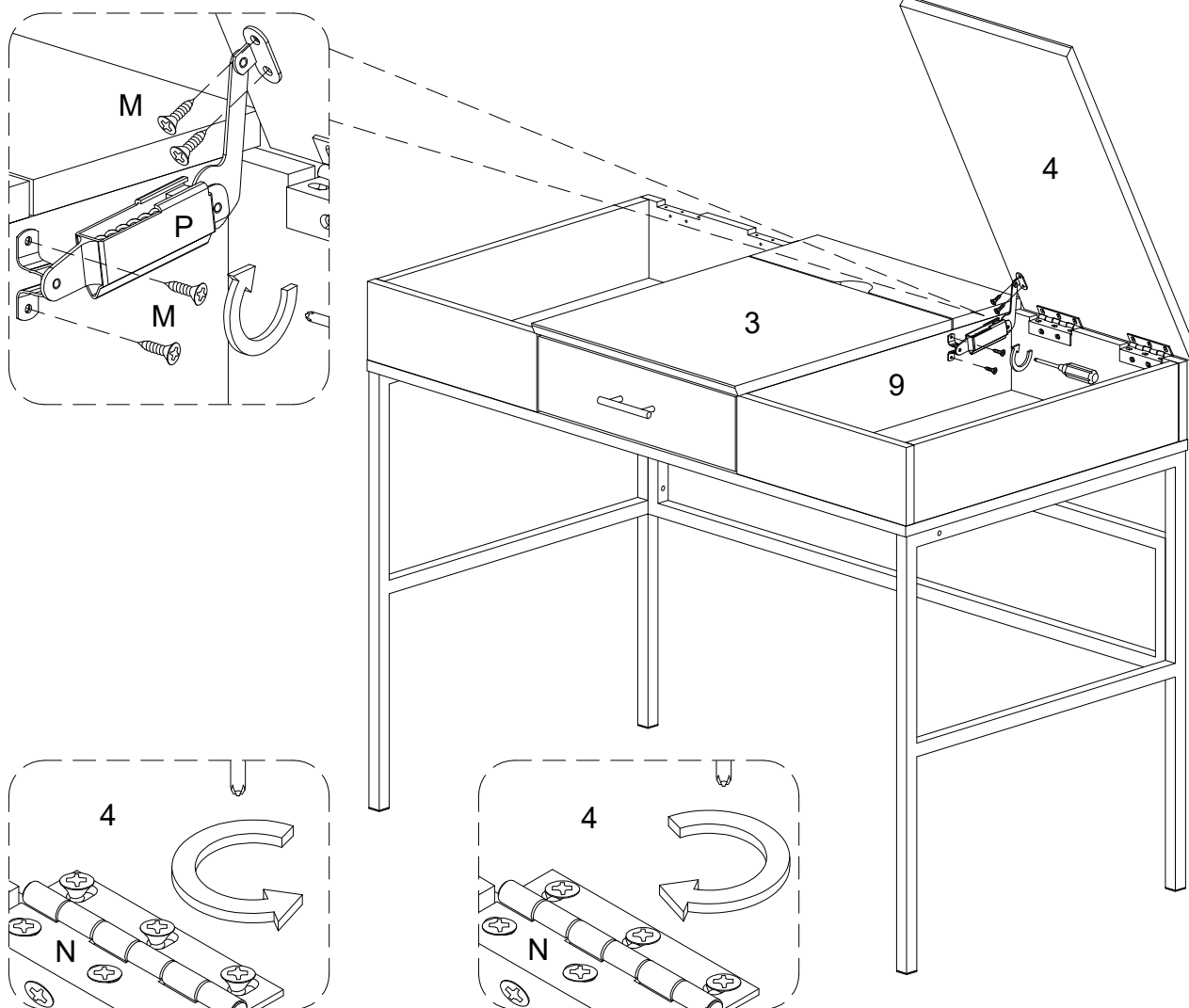

Using screw (M) attach hinge (P) to parts (4,9) with Philips head screwdriver as per diagram. If the gap between the flip door (4) and part (1,3) needs to be adjusted, please first loosen the screws fixing hinge (N) to the flip door (4), finely adjust one side of the flip door (4) up or down, and then lock the hinge (N).

Step 23

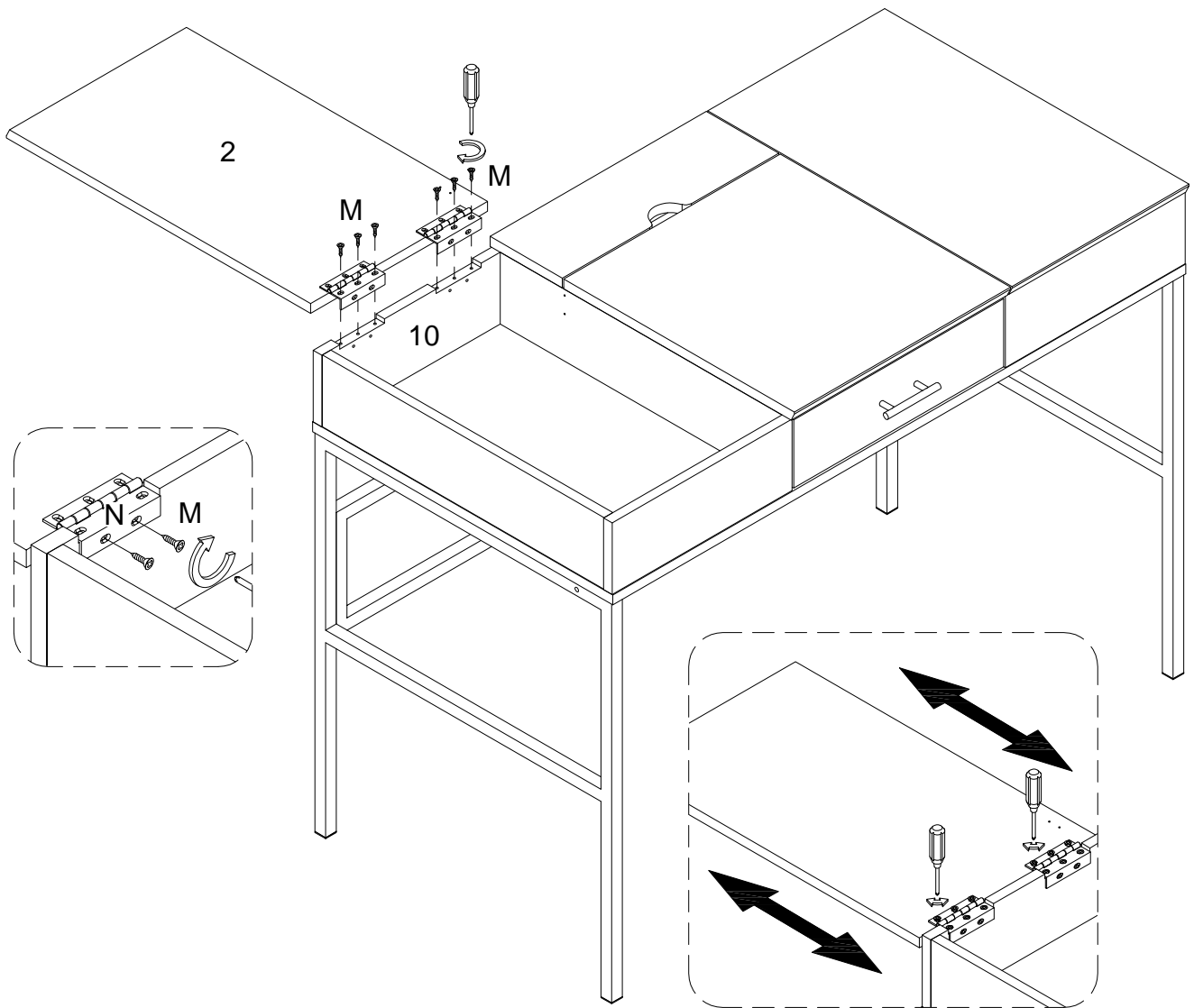

Using screw (M) attach hinge (N) to part (10) with Philips head screwdriver as per diagram.

Step 24

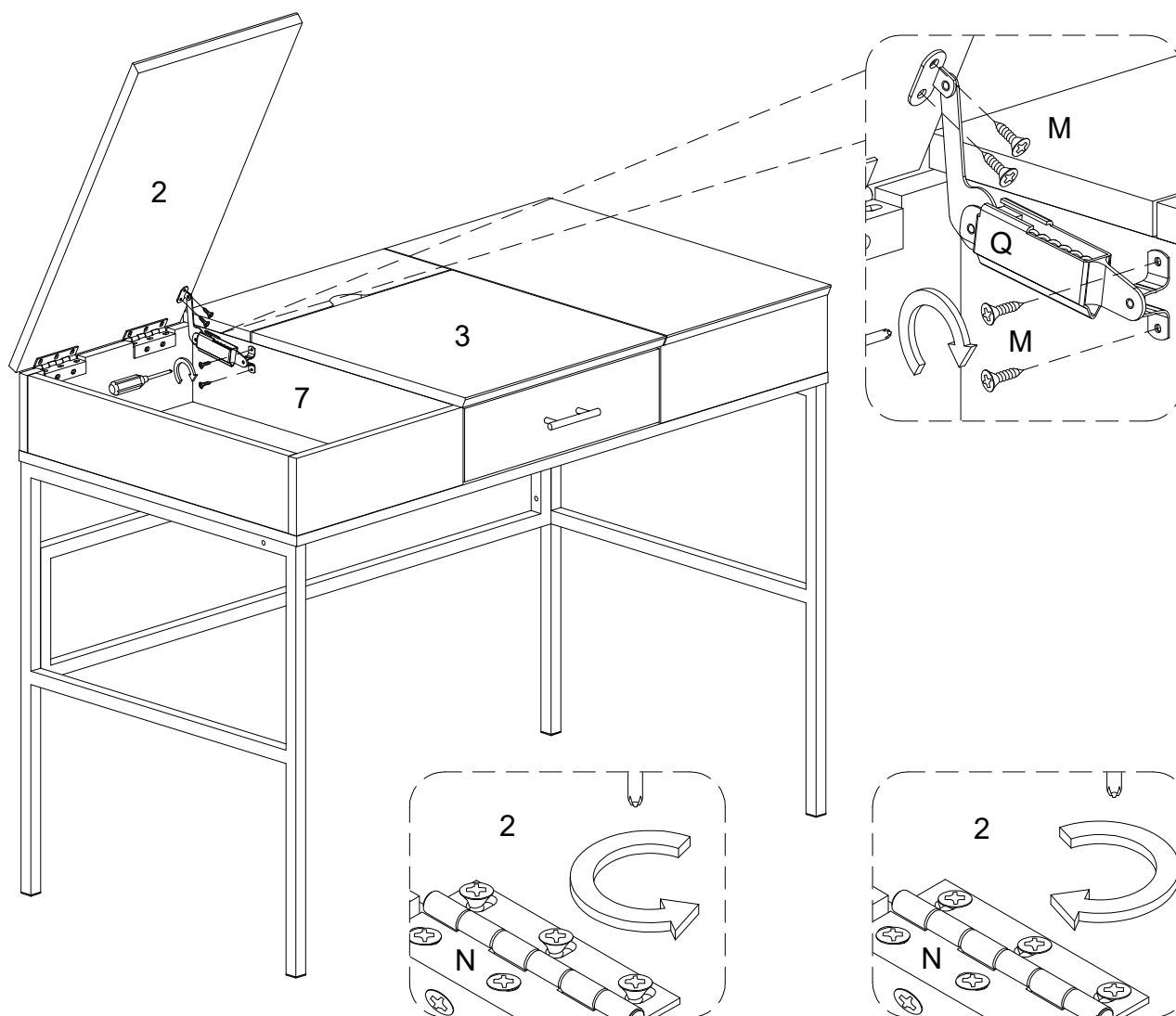

Using screw (M) attach hinge (Q) to parts (2,7) with Philips head screwdriver as per diagram. If the gap between the flip door (2) and part (1,3) needs to be adjusted, please first loosen the screws fixing hinge (N) to the flip door (2), Finely adjust one side of the flip door (2) up or down, and then lock the hinge (N).

Step 25

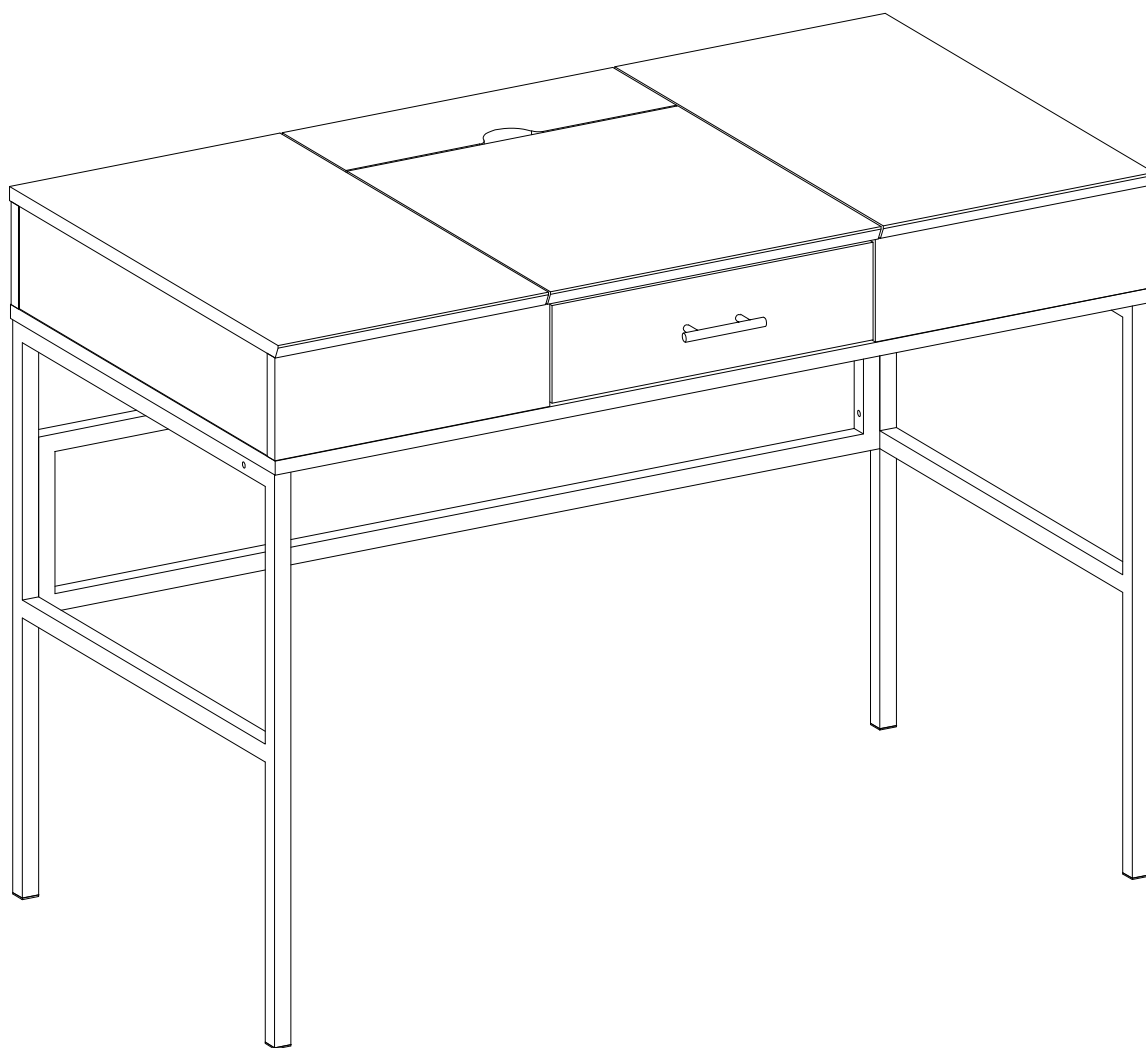

Final Assembly