

Assembly Instructions
Instrucciones De Ensamblaje
Instructions D'Assemblage



877-472-4296

www.medalsports.com

LIMITED 90 DAYS WARRANTY

This product is covered by a limited warranty that is effective for 90 days from the date of purchase. If, during the limited warranty period, a part is found to be defective or breaks, we will offer replacement parts at no cost to you, the customer. The only exceptions to the warranty include mainframes, table tops, playing surfaces, batteries or tools.

The above warranty will not apply in cases of damages due to improper usage, alteration, misuse, abuse, accidental damage or neglect.

This Limited Warranty gives you specific legal rights and you may also have other rights vary from one State (province) to another.

A PURCHASE RECEIPT (or other proof of purchase) will be required before any warranty service is initiated. For all requests for warranty service, please feel free to contact our Consumer Service Department.

Please be aware of your product's Limited Warranty for the return/refund policy from the store. We, at Medal Sports, cannot handle the product which is out of product's limited warranty since we only provide available parts. Thank you!

PLEASE CONTACT US BEFORE RETURNING THE PRODUCT TO THE STORE!

GARANTÍA LIMITADA DE 90 DÍAS

Este producto está cubierto por una garantía limitada que tiene una vigencia de 90 días a partir de la fecha de su compra. Durante el período de la garantía limitada, si una parte defectuosa o quebrada es encontrada, nosotros ofreceremos una reparación o un reemplazo de la partes sin ningún costo para usted, nuestro cliente. Las únicas excepciones de la garantía incluyen unidades centrales, tableros de mesa, superficies de juego, pilas o herramientas.

La susodicha garantía no se aplicará en los casos de daños debido al uso impropio, la alteración, el mal uso, el abuso, el daño accidental o la negligencia.

Esta garantía limitada le da a usted derechos legales específicos, usted también puede tener otros derechos que varían de un estado (provincia) a otro.

EL RECIBO DE LA COMPRA (U otra prueba de compra) sería requerida antes que cualquier servicio de garantía fuera iniciada. Para todo pedido por servicio de garantía, por favor siéntase libre de ponerse en contacto con nuestro Departamento de Servicio de Consumidor.

Por favor tenga en cuenta sobre la Garantía Limitada de su producto para la política de vuelta/reembolso desde la tienda. Nosotros, Medal Sports, no podemos manejar el producto que está fuera del límite de garantía ya que proporcionamos solamente partes disponibles. ¡Gracias!

¡POR FAVOR PÓNGASE EN CONTACTO CON NOSOTROS ANTES DE DEVOLVER EL PRODUCTO A LA TIENDA!

GARANTIE LIMITEE DE 90 JOURS

Ce produit est couvert par une garantie limitée valable 90 jours à compter de la date d'achat. Si pendant cette période une pièce est jugée défectueuse ou se casse, nous la remplacerons gratuitement. Les seules exceptions à la garantie comprennent les armatures principales, les dessus de table, les surfaces de jeu, les piles ou les outils.

La garantie ci-dessus ne s'applique pas en cas de dommages occasionnés par une mauvaise utilisation, une altération, un abus, des un dommage accidentel ou une négligence.

Cette garantie limitée vous accorde des droits légaux spécifiques ainsi que d'autres droits variant d'un état (province) à un autre.

UNE FACTURE D'ACHAT (ou toute autre preuve d'achat) sera exigée avant toute intervention sous garantie. Pour toute demande d'intervention sous garantie, veuillez contacter notre Service Clientèle.

Comprenez votre garantie limitée de produit en ce qui concerne notre politique de retour/remboursement depuis le magasin. Chez Medal Sports, nous ne pouvons pas traiter un produit qui n'est plus sous garantie puisque nous ne pouvons que fournir les pièces disponibles. Remerciements!

VEUILLEZ NOUS CONTACTER AVANT DE RETOURNER LE PRODUIT AU MAGASIN!



WE ARE READY TO HELP

DO NOT RETURN TO STORE

ESTAMOS LISTOS AYUDA

NO DEVOLVERLO A LA TIENDA

NOUS SOMMES PRÊTS À VOUS AIDER

NE PAS RAPPORTER EN MAGASIN

Please Contact | Por favor Contactar | Veuillez contacter

MD SPORTS

Customer Service
Toll Free

Servicio al Cliente
Llamada Gratuita

Service Clientèle
Appel Gratuit

877-472-4296

Mon.-Fri.,
9:00 a.m. to 5:00 p.m. EST

Lunes a Viernes,
9:00 a.m. a 5:00 p.m. ET

Du lundi au vendredi de
9:00 a 17 heures HNE

For additional resources and
Frequently Asked Questions,
please visit us at

Por mayor información y
Preguntas Frecuentes, favor
visitarnos en

Pour toute information
complémentaire ou réponse
aux questions fréquentes,
veuillez vous rendre sur

www.medalsports.com

TOOLS REQUIRED

Phillips Screwdriver - **Not Included**
Standard (Flat Head) Screwdriver - **Not Included**
Wrench - **Included**

HERRAMIENTAS NECESARIAS

Destornillador Phillips - **No incluido**
Destornillador de Cabeza Plana - **No incluido**
Llave Inglesa - **Incluido**

OUTILS REQUIS

Tournevis cruciforme - **Non inclus**
Tournevis standard (Tête plate) - **Non inclus**
Clé anglaise - **Incluse**

 **RECOMMENDED**

Electric Screwdrivers may be helpful during assembly; however, please set a low torque and use extreme caution.

 **RECOMENDADO**

Los destornilladores eléctricos pueden ser de gran ayuda durante el ensamblado; sin embargo, por favor ajuste el par de giro bajo y sea extremadamente precavido.

 **RECOMMANDÉ**

Un tournevis électrique peut être utile pour l'assemblage; utilisez cependant une vitesse de rotation lente et avec prudence.



Power Tools: **Set to Low Torque**
/Herramientas eléctricas: **Establecer a baja velocidad**
/Visseuse électrique: **Couple faible**



High Torque Over Tightened
/Una alta velocidad puede apretar demasiado
/Un couple élevé peut créer des dommages

 **IMPORTANT NOTICE**

1. This product is intended for INDOOR use only.
2. Please do not sit, climb or lean on the product.
3. Please do not drag the product when moving it in order to avoid damaging the legs.
4. Please only use furniture polish spray to clean the exterior surfaces of the product.
5. This is not a children's toy.
6. Adult assembly required.

AVISO IMPORTANTE

1. Este producto está destinado para el uso INTERIOR solamente.
2. Por favor no se siente, suba o incline sobre el producto.
3. Por favor no arrastre el producto cuando lo mueva de lugar para evitar daño en las patas de la mesa.
4. Por favor use solamente spray de pulido para muebles para limpiar la superficie exterior del producto.
5. Este no es un juguete para niños.
6. El ensamblaje debe ser realizado por un adulto.

NOTE IMPORTANTE 

1. Ce produit est conçu pour une utilisation en intérieur uniquement.
2. Veuillez ne pas vous asseoir, grimper ou vous appuyer sur la produit.
3. Veuillez ne pas déplacer la produit en la tirant pour ne pas endommager les pieds.
4. Veuillez utiliser seulement le vernis pour meuble pour nettoyer les surfaces extérieures du produit de jeu.
5. Ce n'est pas un jeu d'enfant.
6. L'assemblage doit être effectué par des adultes.



At least 2 adults needed
Se necesitan al menos 2 adultos
Il faut au moins 2 adultes



No children in assembly area
No deben estar los niños en el area de ensamble
Pas d'enfants dans la zone d'assemblage



Keep away from pets in assembly area
Mantener alejados a los animales domesticos del area de ensamble
Tenir les animaux de compagnie à distance



Do not use or keep product outdoors. For indoor use only. No wet/humid conditions.







No usar o guardar el producto en el exterior. Solo para uso en interior. No utilizar ni guardar el producto en lugares húmedos o mojados.

N'utilisez ni ne stockez ce produit en extérieur. Uniquement pour utilisation en intérieur. Ne pas exposer à l'humidité.

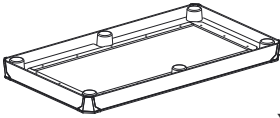
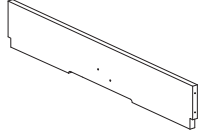
PARTS IDENTIFIER

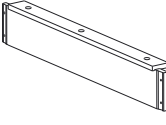
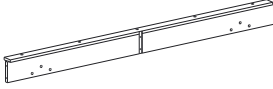
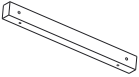
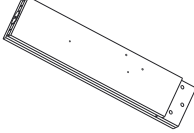
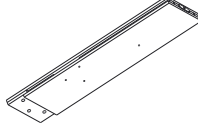
IDENTIFICADOR DE PIEZAS



IDENTIFICATEUR DE PIÈCES

PART NUMBER NÚMERO DE PIEZA NUMÉRO D'ARTICLE			1			FOR FIG. 4			FIG. NUMBER NÚMERO DE FIG. NUMÉRO FIG.														
PART PIEZA PIÈCE						x1			QUANTITY CANTIDAD QUANTITÉ														
PART NAME			Mainframe	Unidad principal	Unité centrale				NOM DE LA PIÈCE NOMBRE DE PIEZA														
2			FOR FIG. 1			3			FOR FIG. 1			4			FOR FIG. 2			5			FOR FIG. 2		
			x1						x1						x2						x2		
Support Board	Tablero de soporte	Plateau de support	Adjustable Bracket	Corchete regulable	Support réglable	End Top Board	Tablero superior final	Panneau supérieur final	Side Top Board	Tablero superior lateral	Panneau supérieur latéral												
6			FOR FIG. 5			7			FOR FIG. 5			8			FOR FIG. 5			9			FOR FIG. 7		
			x4						x2						x2						x2		
Support Brace	Abrazadera de soporte	Barre de support	Right Leg	Pata derecha	Pied droit	Left Leg	Pata izquierda	Pied gauche	Side Leg Panel	Panel lateral para pata	Panneau latéral du pied												
10			FOR FIG. 9			11			FOR FIG. 10														
			x2						x4														
End Leg Panel	Panel de extremo para pata	Panneau inférieur du pied	Leg Leveler	Nivelador de pata	Niveleur de pied																		

ACCESSORIES

ACCESORIOS

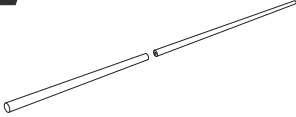
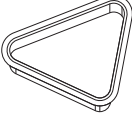
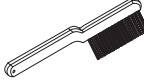

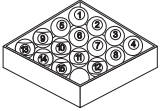



ACCESSOIRES

12			13			14			15														
			x2						x1						x1						x2		
Cue	Taco	Queue de billard	Triangle	Triángulo	Triangle	Brush	Cepillo	Brosse	Chalk	Tiza	Craie												
16																							
			x1																				
Billiard Ball Set	Bola de billar	Ensemble boules de billard																					

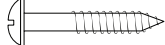
HARDWARE

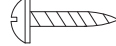
HARDWARE

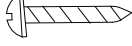
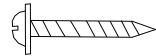







MÉTAUX

A1 FOR FIG. 1			A2 FOR FIG. 2, 3, 5			A3 FOR FIG. 4			A4 FOR FIG. 4		
											
x2			x20			x16			x16		
M5x25mm Bolt	Perno M5x25mm	Boulon M5x25mm	4x45mm Screw	Tornillo 4x45mm	Vis 4x45mm	M6x22mm Bolt	Perno M6x22mm	Boulon M6x22mm	M6 Washer	Arandela M6	Rondelle M6
A5 FOR FIG. 4			A6 FOR FIG. 6, 7			A7 FOR FIG. 6, 7			A8 FOR FIG. 8		
											
x2			x12			x12			x8		
4x12mm Screw	Tornillo 4x12mm	Vis 4x12mm	M8x45mm Bolt	Perno M8x45mm	Boulon M8x45mm	M8 Washer	Arandela M8	Rondelle M8	4x21mm Screw	Tornillo 4x21mm	Vis 4x21mm
A9 FOR FIG. 9			A10								
											
x8			x1								
3.5x28mm Screw	Tornillo 3.5x28mm	Vis 3.5x28mm	Wrench	Llave inglesa	Clé anglaise						

PRE-INSTALLED PARTS

PIEZAS PREINSTALADAS

PIÈCES PRÉINSTALLÉES

P1 FOR FIG. 1			P2 FOR FIG. 5			P3 FOR FIG. 2			P4 FOR FIG. 11		
											
x2			x4			x12			x4		
M5 T - Nut	Tuerca - T M5	Écrou en T M5	Square Nut with Screws	Tuerca cuadrada con tornillos	Écrou carré avec vis	M8 T - Nut	Tuerca - T M8	Écrou en T M8	Top Corner	Esquina superior	Coin supérieur
P5 FOR FIG. 11			P6 FOR FIG. 11			P7 FOR FIG. 4			P8 FOR FIG. 11		
											
x4			x2			x6			x4		
Corner Pocket	Tronera de la esquina	Poche de coin	Side Pocket	Tronera lateral	Poche latérale	Fabric Pocket	Bolsillo de tela	Poche en tissu	Apron Corner	Cubierta de esquina	Tablier de coin

BEFORE ASSEMBLY

ANTES DE MONTAR

AVANT L'ASSEMBLAGE

1. Find a clean, level place to begin the assembly of your product.
2. Verify that you have all listed parts as shown on the part list pages. If any parts are missing, call our customer service.

1. Encuentre un lugar limpio y nivelado para comenzar el ensamblaje del producto.
2. Compruebe que tenga todas las piezas que se muestran en la lista de piezas. Si falta alguna pieza, llame a nuestro servicio al cliente.

1. Trouvez un endroit propre et plat pour commencer à assembler votre produit.
2. Vérifiez que vous avez toutes les pièces énumérées comme indiqué sur les pages de liste des pièces. S'il y a des pièces qui manquent, appelez notre service à la clientèle.

ASSEMBLY

MONTAJE

ASSEMBLAGE

FIG. 1

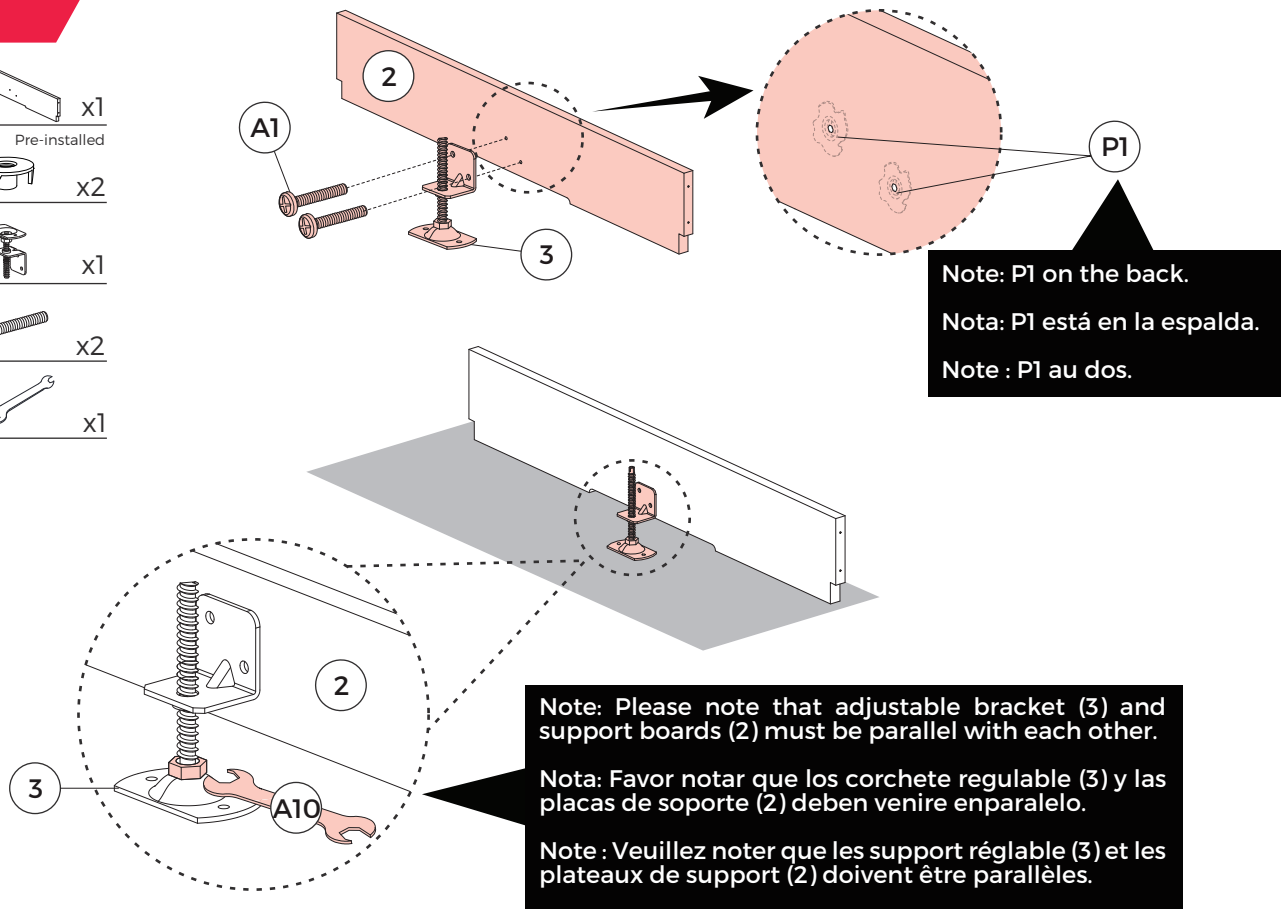
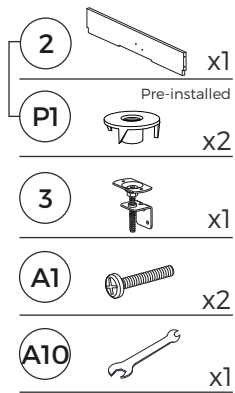
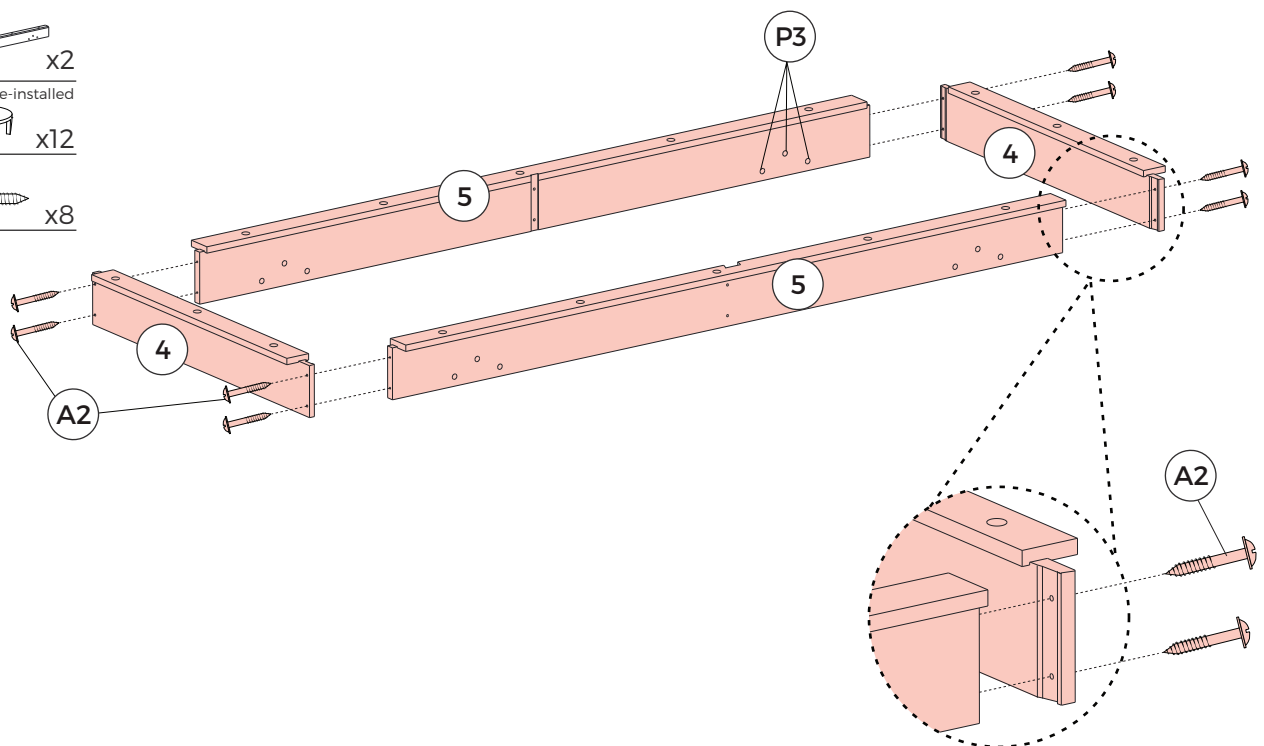
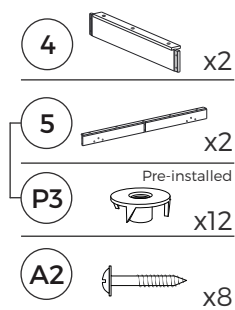

FIG. 2



ASSEMBLY

MONTAJE

ASSEMBLAGE

FIG. 3

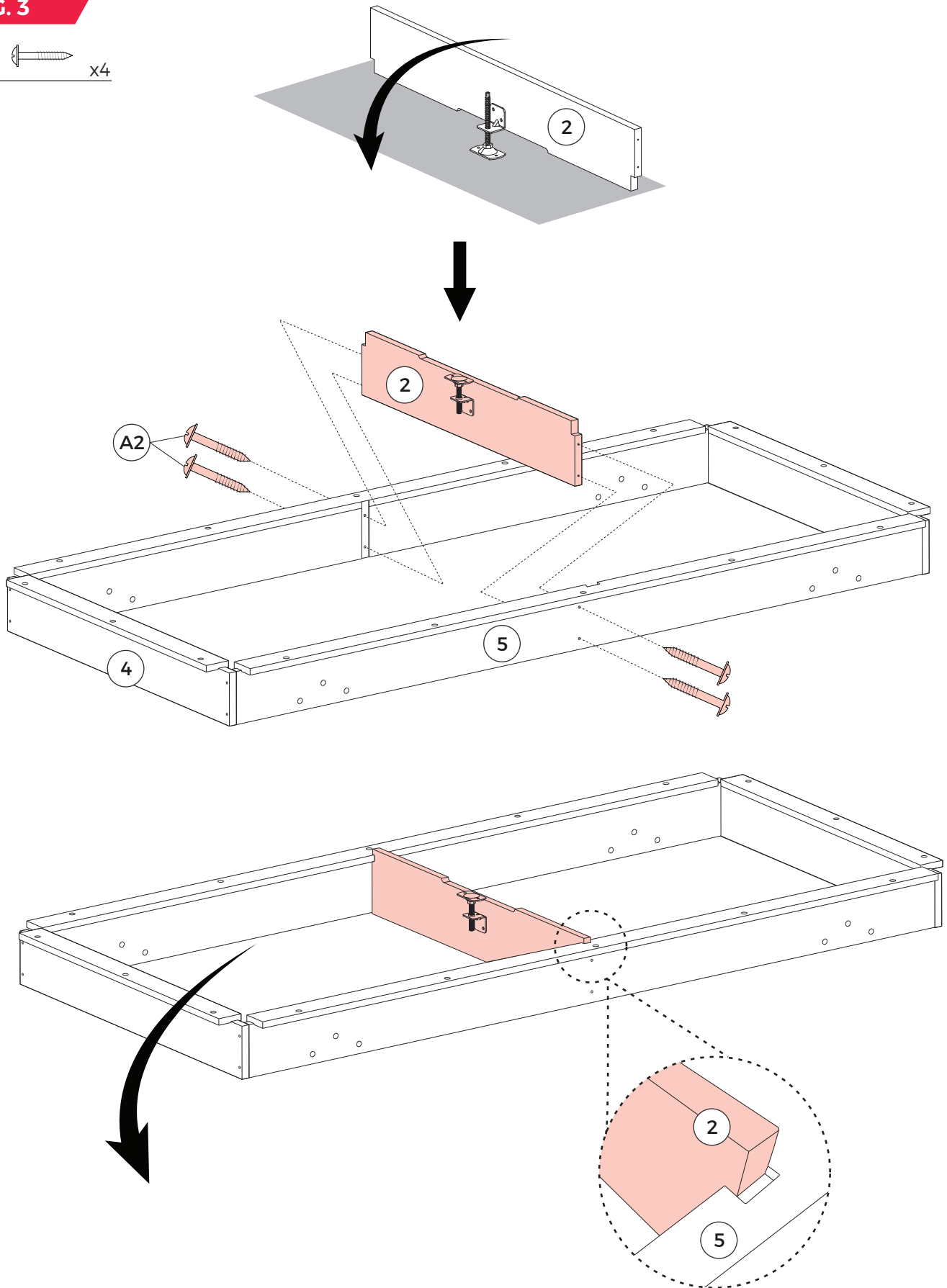
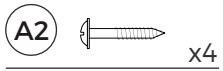

ASSEMBLY

MONTAJE

ASSEMBLAGE

FIG. 4







- 1  x1
- P7  Pre-installed x6
- A3  x16
- A4  x16
- A5  x2
- A10  x1

FIG. 3 Assembly / Ensamblaje FIG. 3 / FIG. 3 Assemblage

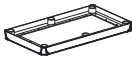



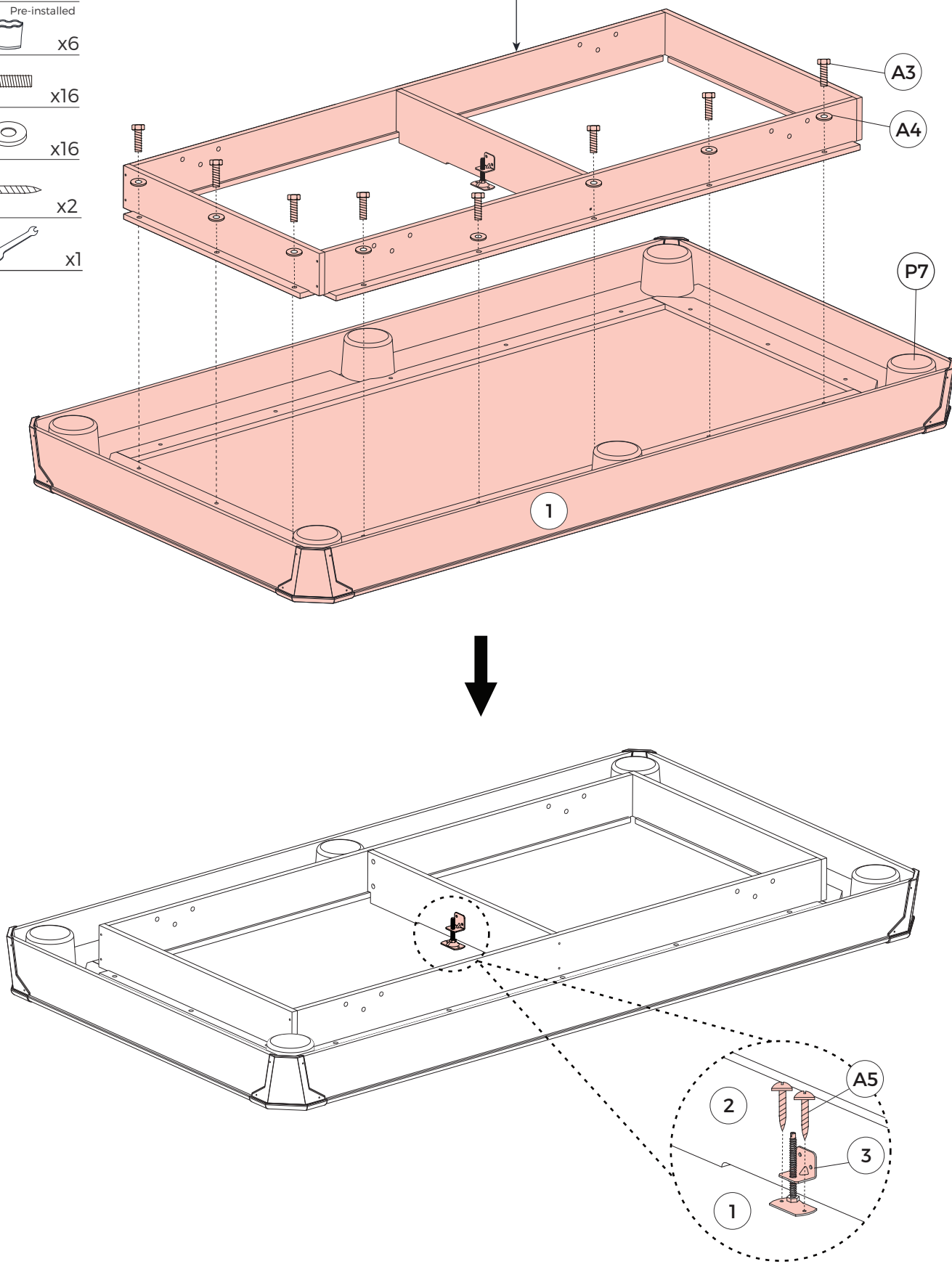

ASSEMBLY

MONTAJE

ASSEMBLAGE

FIG. 5

- 6  x4
- 7  x2
- 8  x2
- P2  x4
Pre-installed
- A2  x8

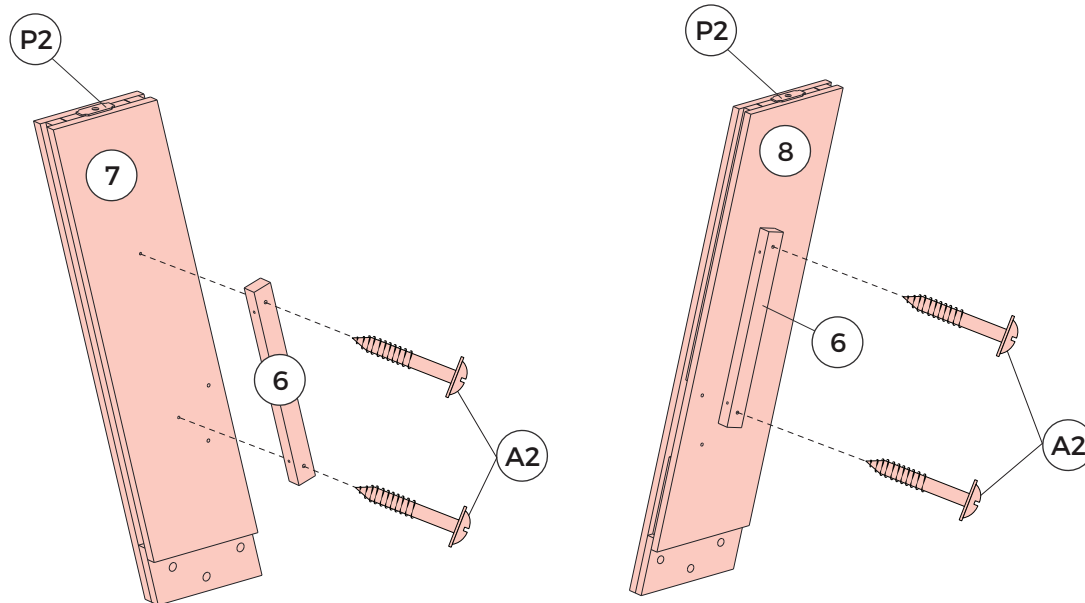



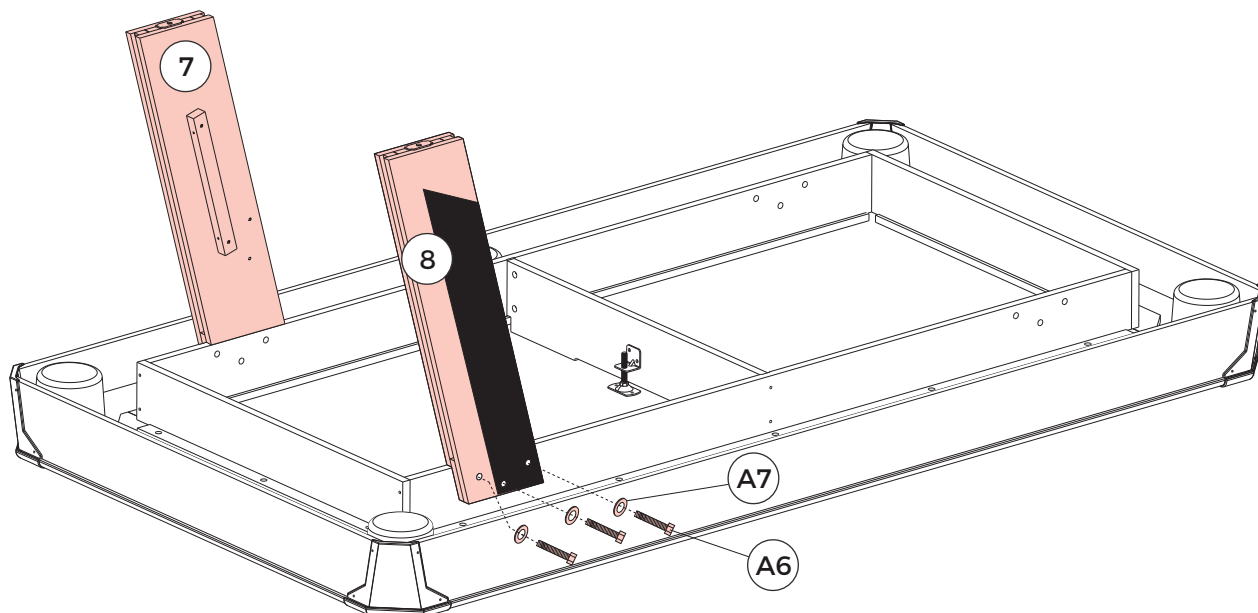
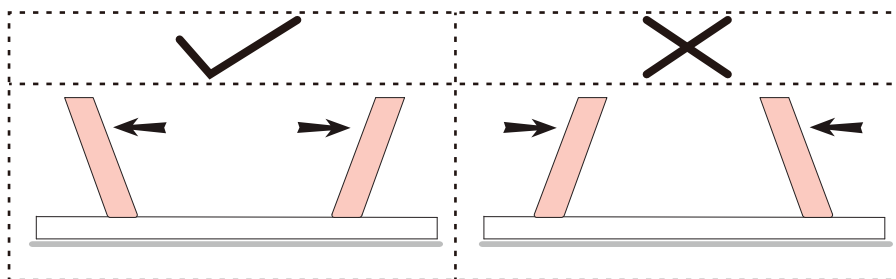

FIG. 6

- A6  x6
- A7  x6
- A10  x1







ASSEMBLY

MONTAJE

ASSEMBLAGE

FIG. 7

- 9  x2
- A6  x6
- A7  x6
- A10  x1

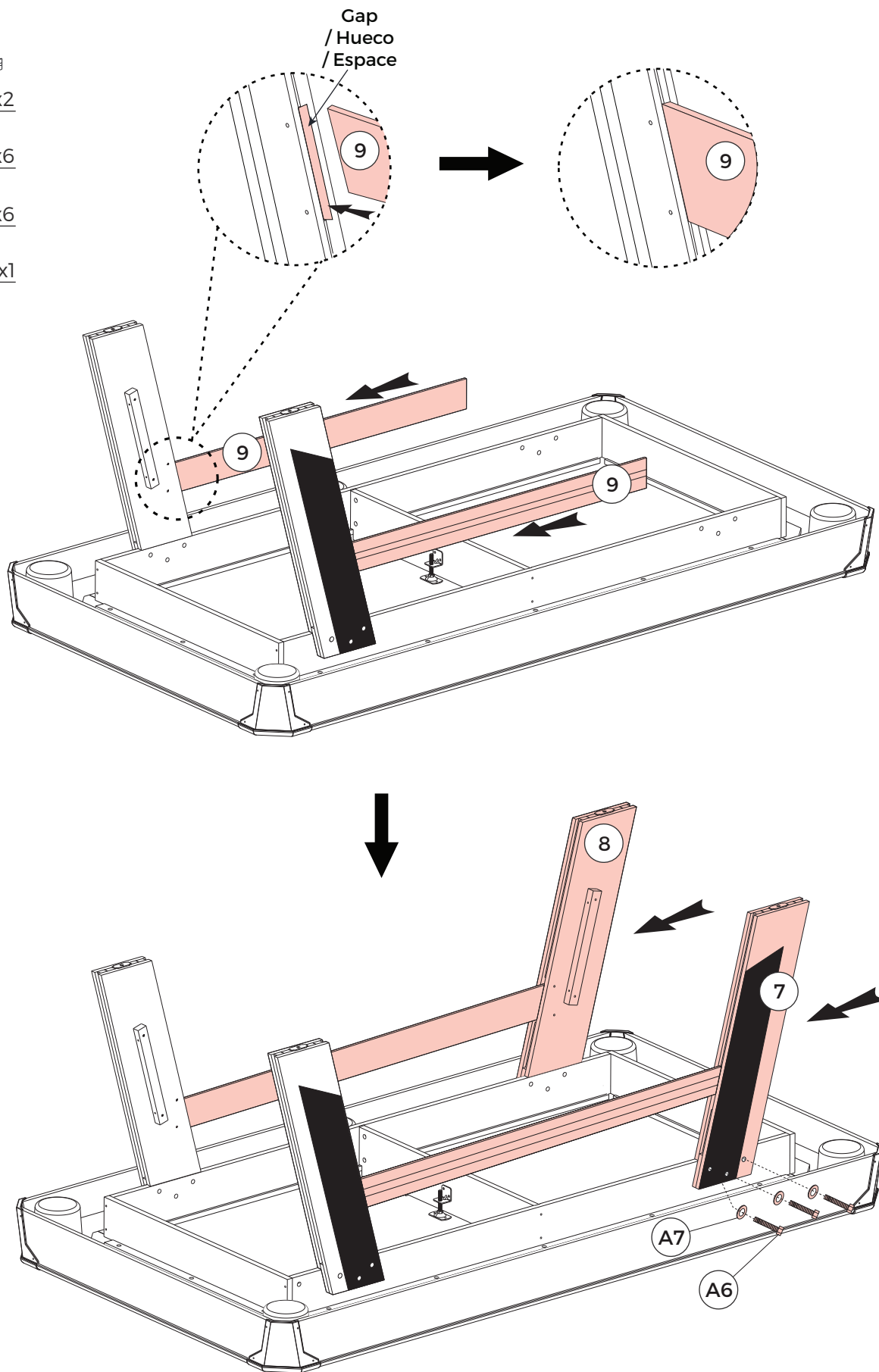

ASSEMBLY

MONTAJE

ASSEMBLAGE

FIG. 8

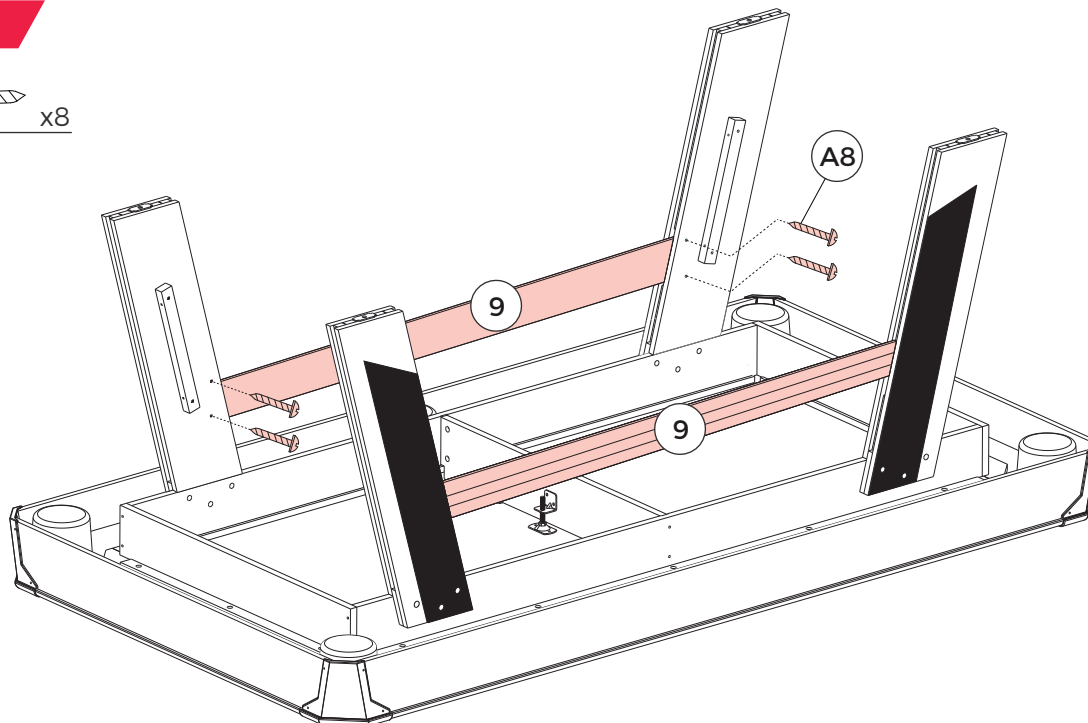
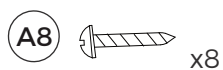
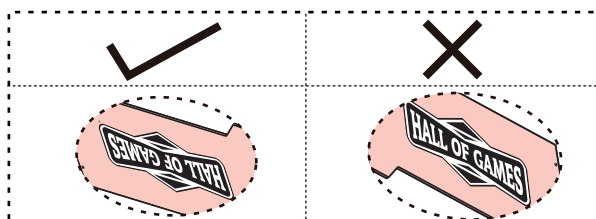
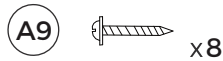

FIG. 9



Note: Both logo panels should be inverted when assembling.

Nota: Ambos paneles del logo deben estar invertidos al ensamblar.

Note : Les deux panneaux logo doivent être inversés pendant l'assemblage.

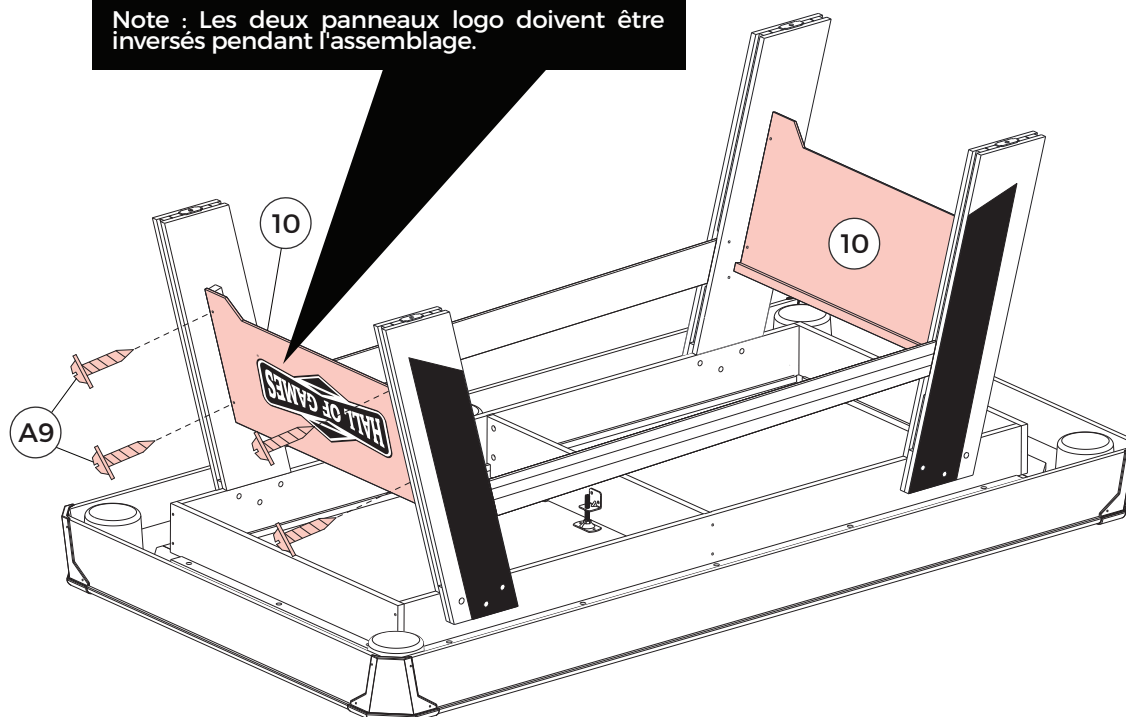

ASSEMBLY

MONTAJE

ASSEMBLAGE

FIG. 10



x4

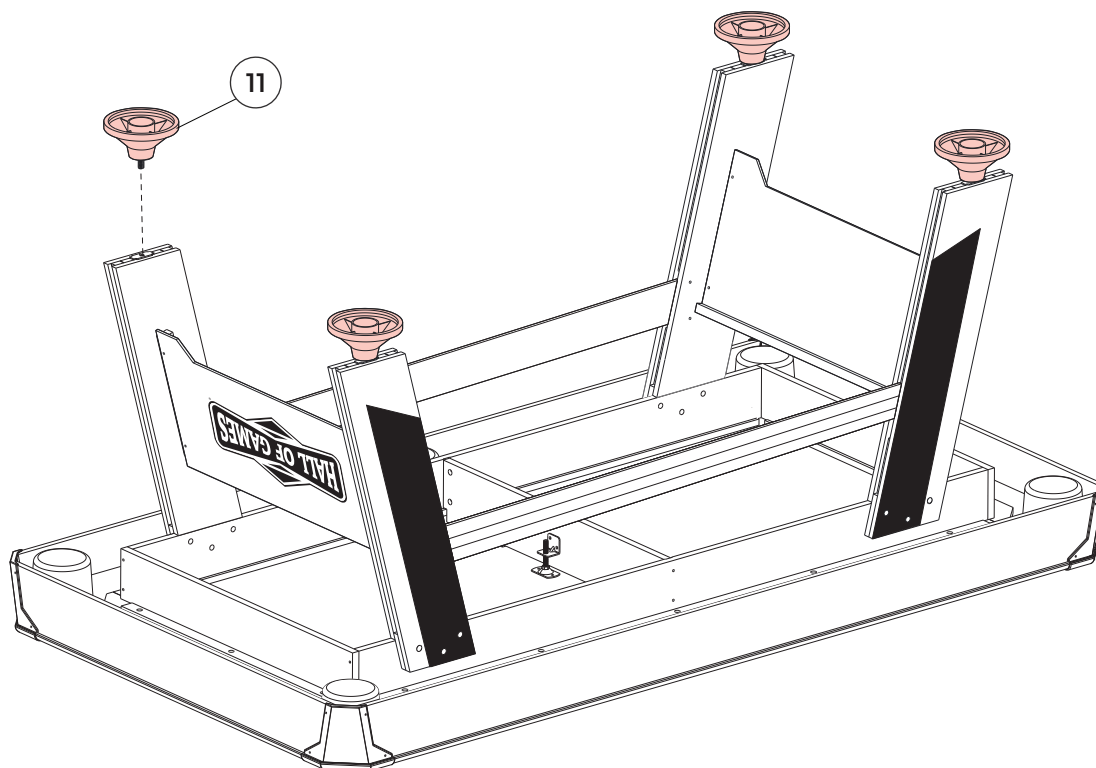

Note: Go back and make sure that all connections are tight.

Nota: Vuelva y asegúrese que todas las conexiones están apretadas.

Note : Revérifiez que toutes les connexions sont bien serrées.

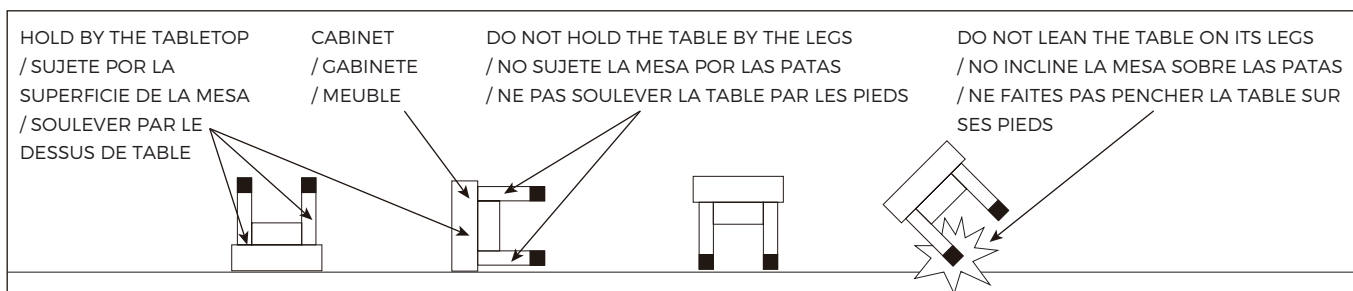

⚠ CAUTION

Two strong adults are recommended to turn over the table as shown.

1. Lift the table off the ground.
2. Turn the table over.
3. Place it on all feet at the same time on the ground.

⚠ PRECAUCIÓN

Se recomienda voltear la mesa entre 2 adultos como se muestra.

1. Levante la mesa del suelo.
2. Voltee la mesa.
3. Coloque las patas de la mesa sobre el piso al mismo tiempo.

⚠ ATTENTION

Il est recommandé que deux adultes forts retournent la table comme indiqué.





1. Soulevez la table du sol.
2. Retournez-la.
3. Placez ses pieds sur le sol simultanément.

ASSEMBLY

MONTAJE

ASSEMBLAGE

FIG. 11

P4		Pre-installed X4
P5		Pre-installed X4
P6		Pre-installed X2
P8		Pre-installed X4

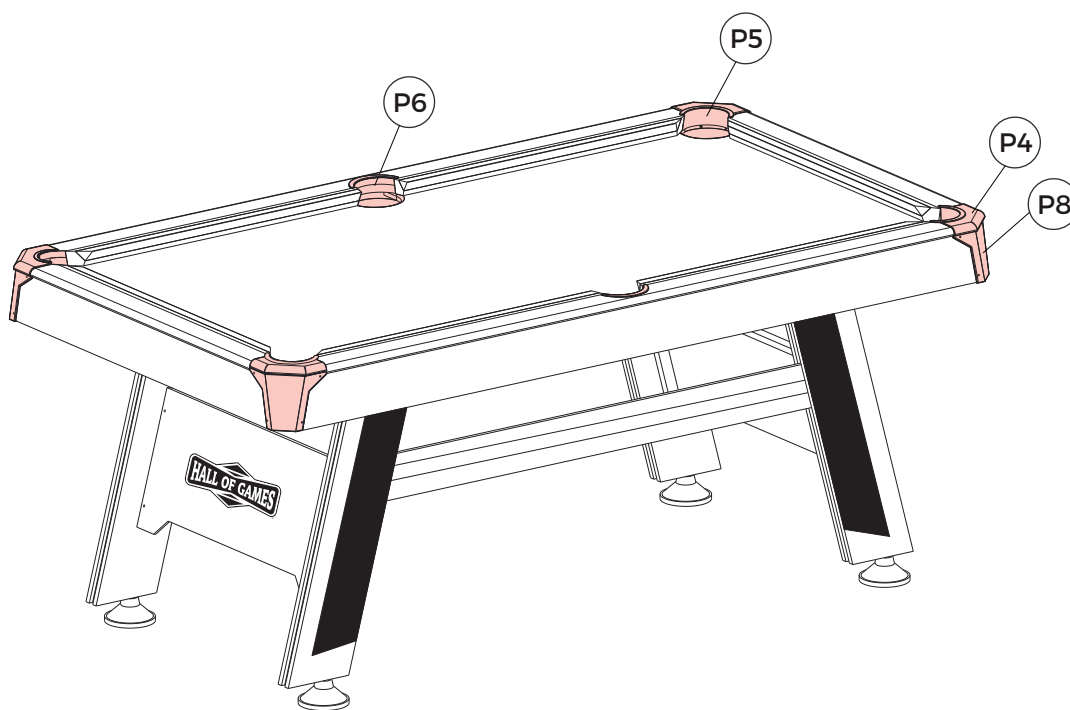

HOW TO LEVEL YOUR TABLE

CÓMO NIVELAR SU MESA

COMMENT LEVER VOTRE TABLE

STEP 1

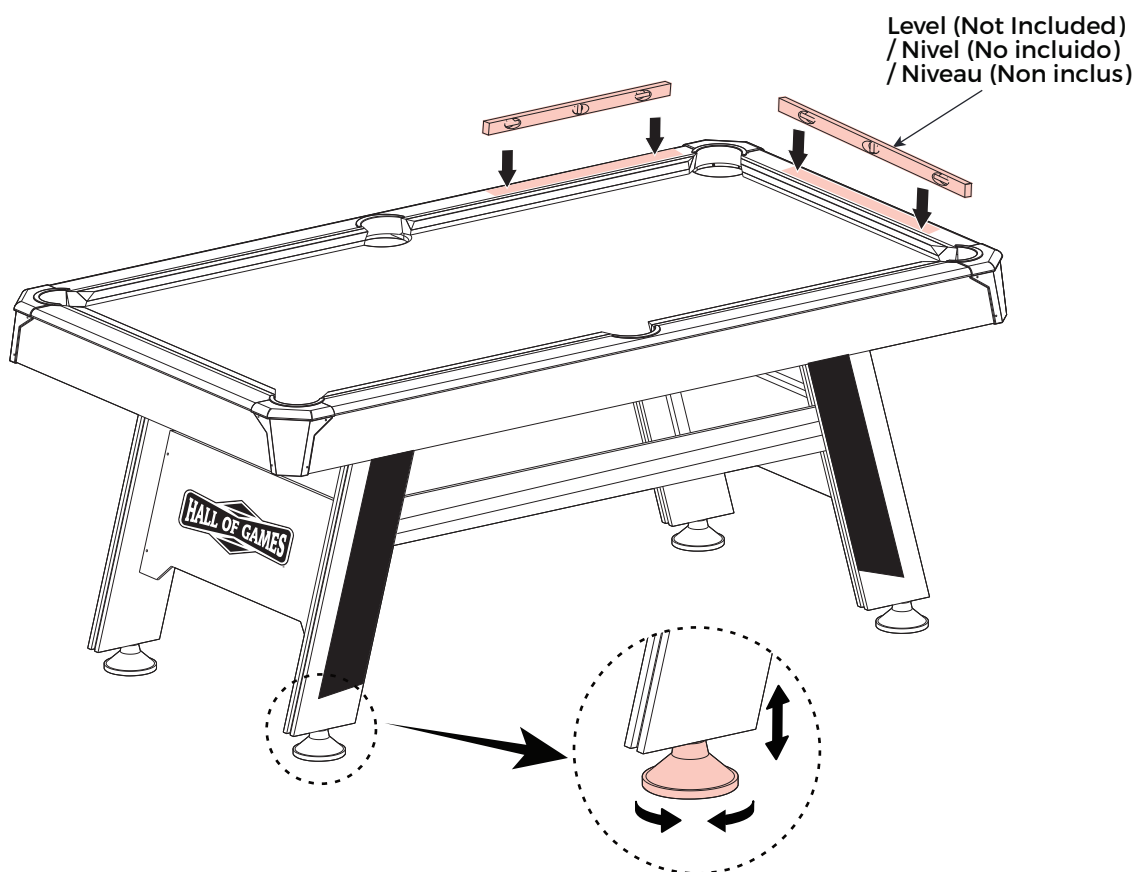

STEP 2

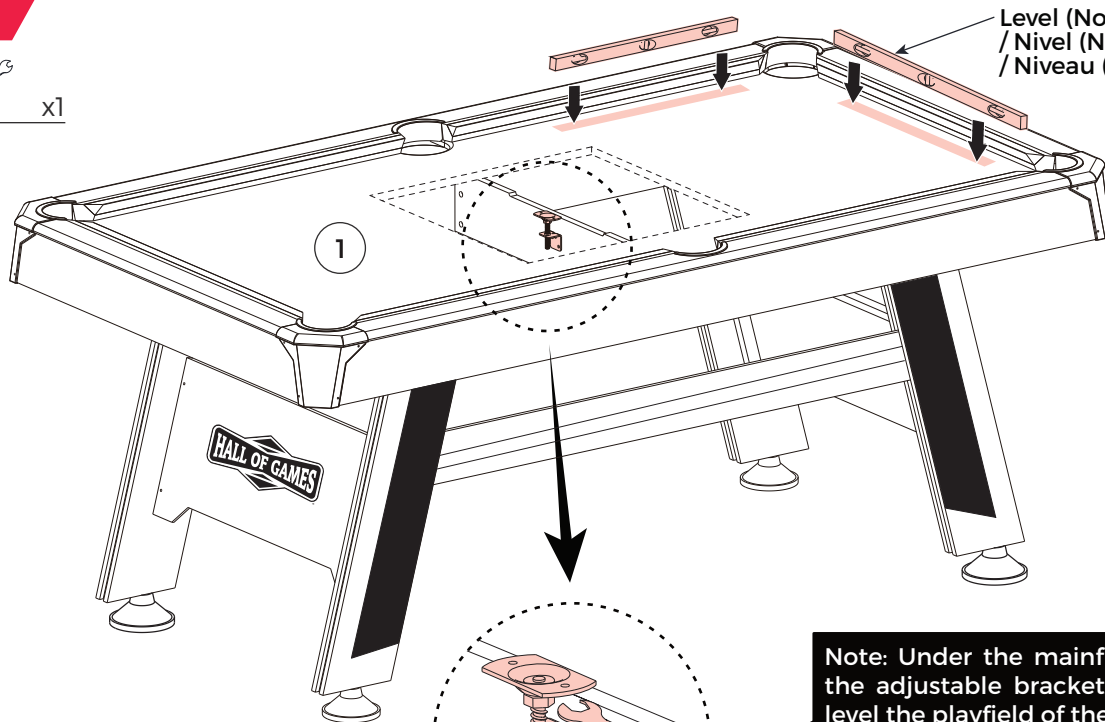

Level (Not Included)
/ Nivel (No incluido)
/ Niveau (Non inclus)

Note: Under the mainframe (1), adjust the adjustable bracket (3) in order to level the playfield of the mainframe.

Nota: Debajo del unidad principal (1), ajuste los corchete regulable (3) por el orden de nivel del campo de juego del unidad principal.

Note : Sous l'Unité centrale (1), réglez les support réglable (3) afin d'aplanir la surface de jeu du l'Unité centrale.

**ADJUST CONCAVE TABLE
/ AJUSTAR LA MESA CÓNCAVA
/ POUR AJUSTER LA TABLE CONCAVE**

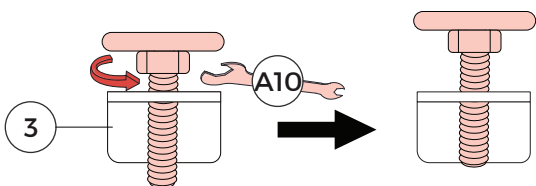

**ADJUST CONVEX TABLE
/ AJUSTAR LA MESA CONVEXA
/ POUR AJUSTER LA TABLE CONVEXE**

