

ASSEMBLY INSTRUCTIONS

TERRA CONSOLE TABLE

ASSEMBLY
REQUIREMENTS

2-Person
Assembly

Assembly Time
(Approximate)
45min

Tools Required
(Not Provided)

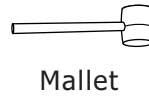

Thank you for purchasing our product!

Please refer and use this assembly instruction to assemble the product. Contact our customer service department in case there are any missing or damage parts or hardware. Replacement parts are normally shipped within 2 or 3 days.

PRODUCTS PURCHASED THROUGH OUR AUTHORIZED VENDORS ONLY ARE ELIGIBLE FOR REPLACEMENTS PARTS.

We appreciate your business!

THIS PRODUCT IS FOR INDOOR AND HOUSEHOLD USE ONLY-NOT FOR COMMERCIAL USE.

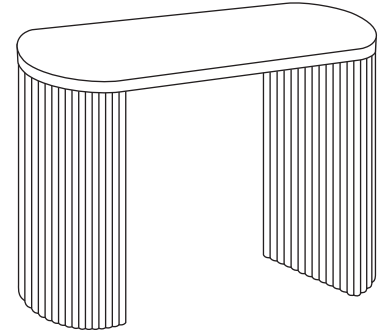

ASSEMBLY PREPARATION

1. Remove all packaging materials, staples and packing straps from the carton.
2. Refer to Parts List and Hardware List, and ensure parts and hardware are correct before assembly. Contact customer service for missing parts.
3. Place all wooden parts on a clean, flat and soft surface (e.g. carpet or rug) to prevent scratch and damaged to parts.

SAFETY PRECAUTION

1. KEEP ALL HARDWARE PARTS OUT OF REACH OF CHILDREN.
2. DISPOSE PLASTIC PACKAGING MATERIAL IMMEDIATELY TO AVOID ANY RISK OF SUFFOCATION TO CHILDREN AND ANIMALS.

TIPS FOR ASSEMBLY

1. Allow ample room for assembly and assemble the product near where the product will be placed.
2. Assemble the product on a surface that does not scratch or damage the exterior gloss and finish of the furniture.
3. Identify all of the parts, hardware and quantities required for each step.
4. During assembly, do not over-tighten any fittings as this may cause damage.
5. DO NOT USE POWER TOOLS TO ASSEMBLE THIS PRODUCT.
6. Always place the product on a flat, level surface.
7. Do not sit or stand on the partially assembled product; only use the product for which it is intended.

CARE AND MAINTENANCE



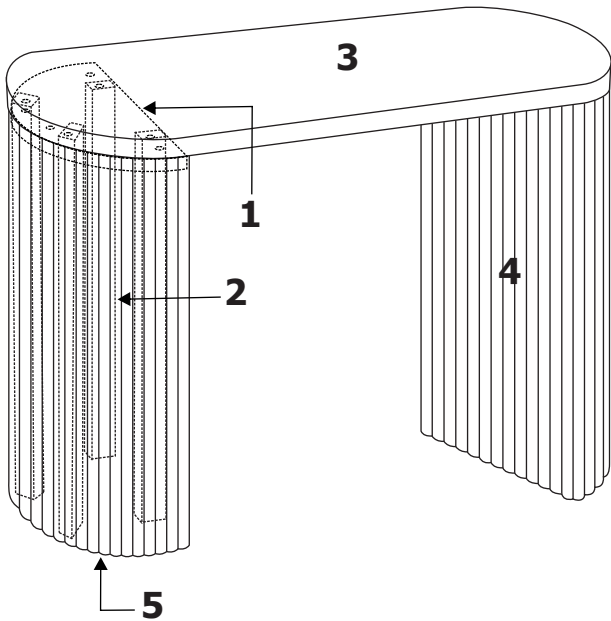

- Wipe clean with a soft, dry cloth; avoid the use of harsh chemicals or household cleaners as they may damage the exterior finish of the furniture.
- Hardware may loosen over time. Periodically, check that all connections are tight; re-tighten as necessary.
- Solid wood is impacted by heat and humidity fluctuations which may cause small joint separations or hairline cracks; place the furniture away from direct sunlight and air conditioning vents, heating vents or units to protect the furniture.

ASSEMBLY INSTRUCTIONS









TERRA CONSOLE TABLE ITEM # 67003



PARTS LIST

No.	Description	Qty
1	Mounting Plate 	2pcs
2	Support Bar 	8pcs
3	Table Top 	1pc
4	Column 	2pcs
5	Bottom Cover 	2pcs

HARDWARE LIST

No.	Description	Qty	Extra
A	JCBC Screw M6 X 35mm 	16pcs	1pc
B	JCBC Screw M6 X 50mm 	8pcs	1pc
C	Spring Washer M6 x 13.5mm 	24pcs	1pc
D	Small Flat Washer M6 x 13.5mm 	8pcs	1pc
E	Big Flat Washer M6 x 18mm 	16pcs	1pc
F	Adjustable Stud 	6pcs	1pc
G	Wood Dowel M8 x 30mm 	8pcs	1pc
H	Wood Screw M4 x 16mm 	8pcs	1pc
I	M4 x 100mm Allen Key 	1pc	-

* Extra Hardware For Spare Use

STEP 1

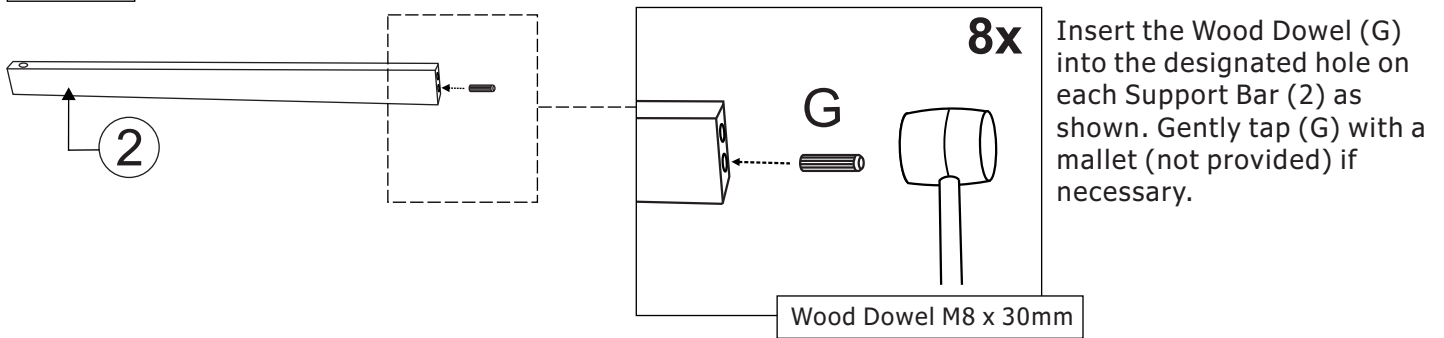

STEP 2

JCBC Screw M6 x 35MM
+ Spring Washer
+ **Small** Flat Washer 13.5mm

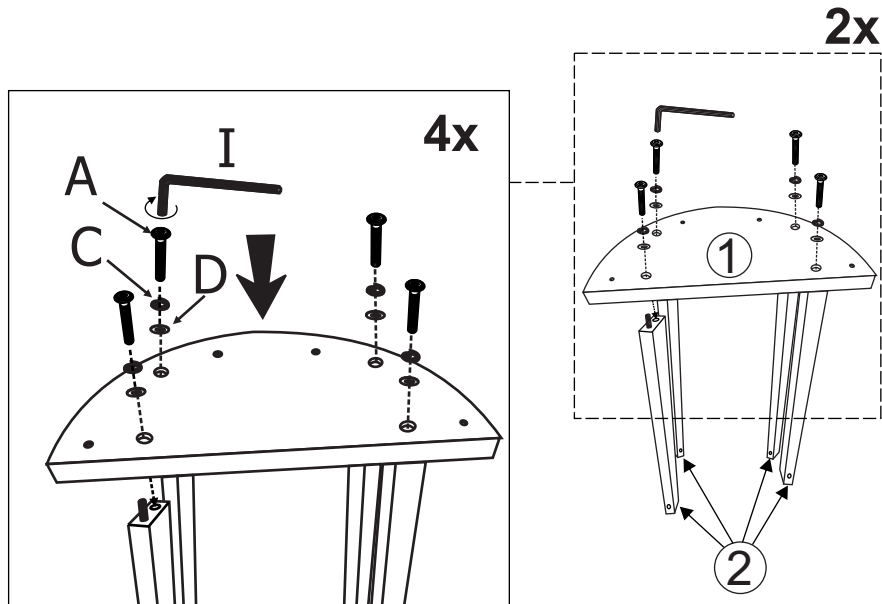
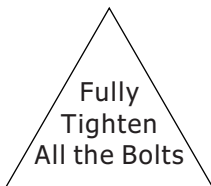

a) Attach Support Bar (2) with wood dowel from STEP 1 to Mounting Plate (1) and fasten using JCBC screw (A) fitted with Spring Washer (C) and Small Flat Washer (D). Use Allen Key (I) to drive and fully tighten (A).

b) Repeat the above procedure for the other three Support Bars.

STEP 3

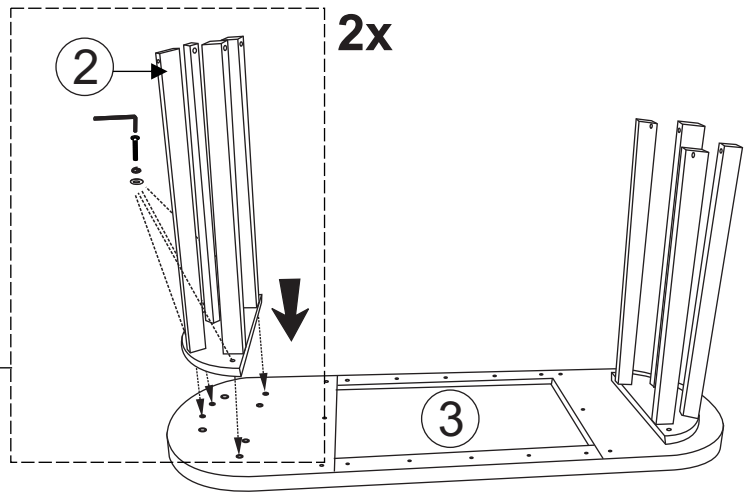
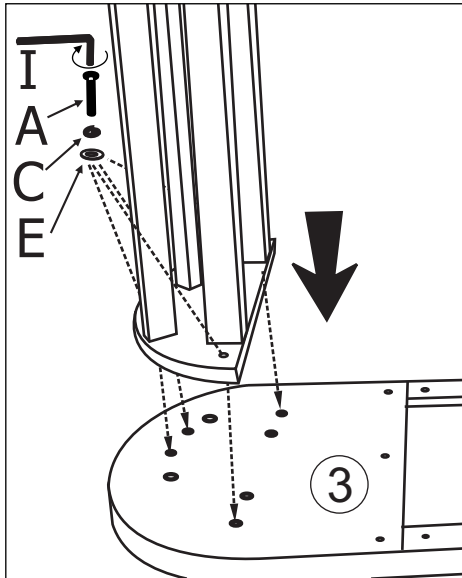

a) Lay Table Top (3) bottom-side up on a material to avoid scratch the part. Attach Mounting Plate with Support Bar assembly from STEP 2 to (3) and fasten with JCBC screw (A) fitted with Spring Washer (C) and Big Flat Washer (E). Use Allen Key (I) to drive and fully tighten (A).

b) Repeat the above procedure for the other Mounting Plate with Support Bar assembly.

JCBC Screw M6 x 35MM
+ Spring Washer
+ Big Flat Washer 18mm

4x

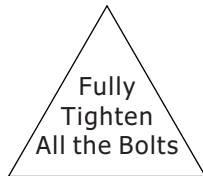

STEP 4

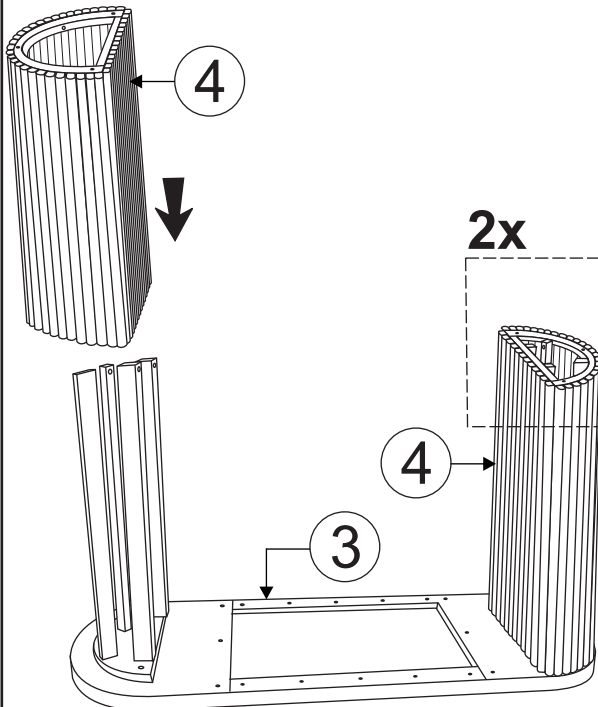

Bottom View

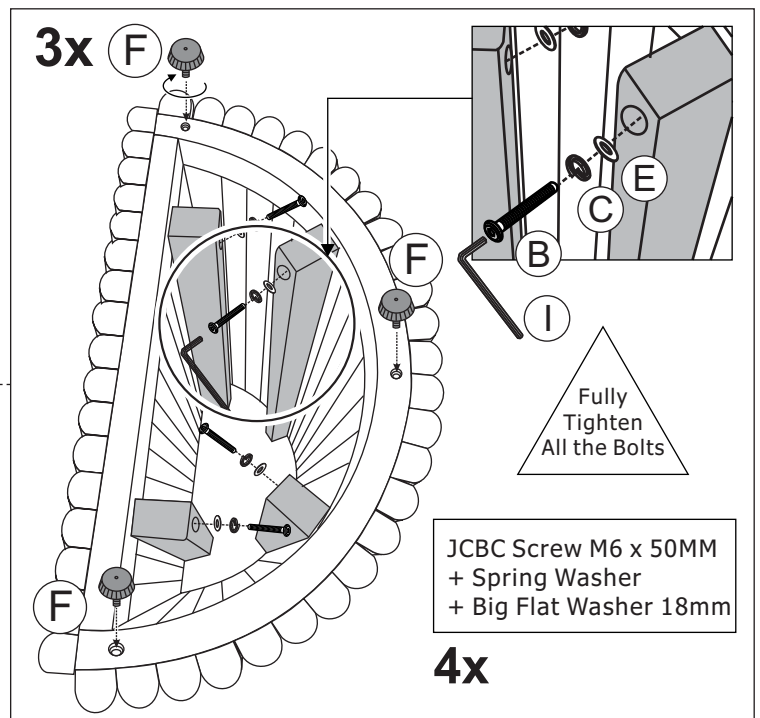

JCBC Screw M6 x 50MM
+ Spring Washer
+ Big Flat Washer 18mm

4x

a) Use Column (4) to encase Support Bar and Mounting Plate assembly and secure with JCBC screw (B) fitted with Spring Washer (C) and Big Flat Washer (E). Use Allen Key (I) to drive and fully tighten (B).

b) Screw in Adjustable Stud (F) to the bottom edge of Column (4) as shown.

STEP 5

Bottom View

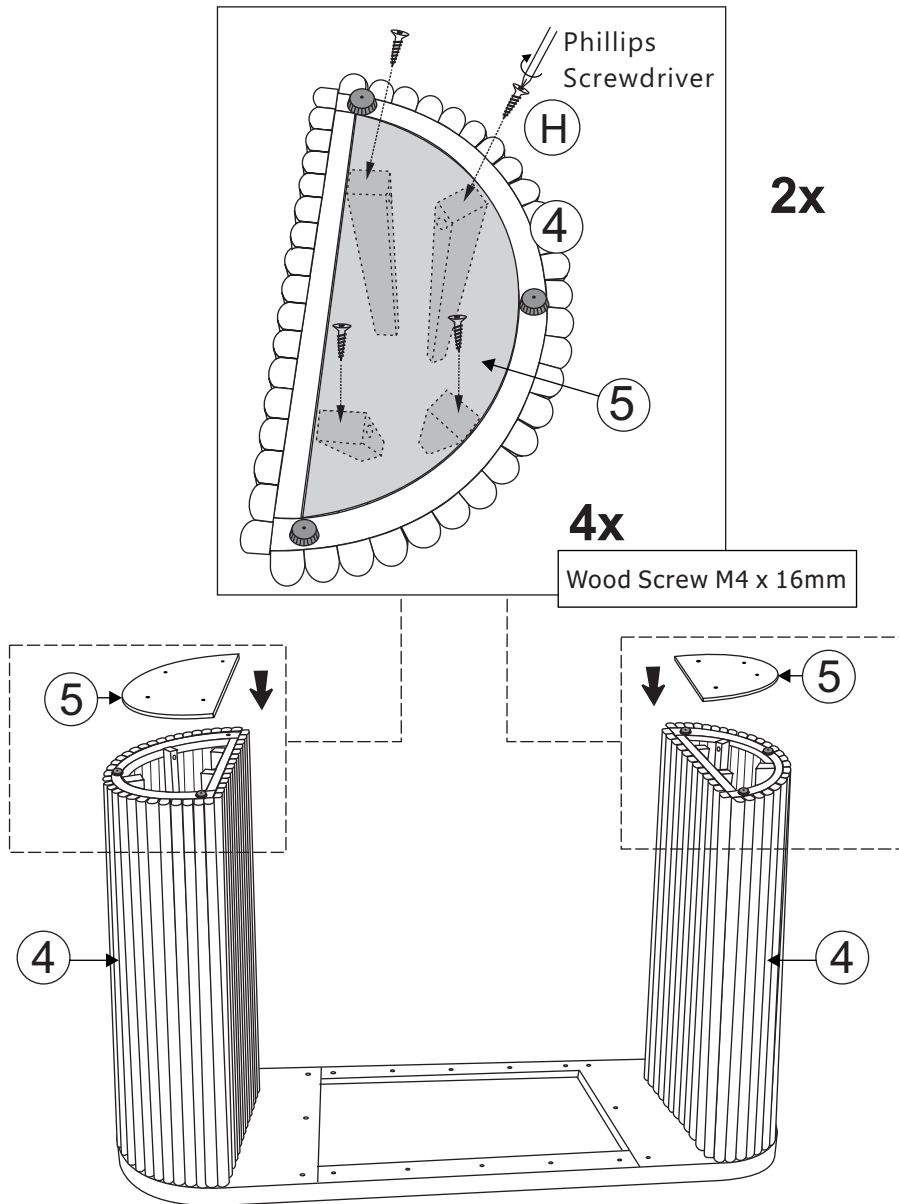

Secure Bottom Cover (5) to Column (4) with Wood Screw (H). Use Phillips screwdriver (not provided) to fully tighten (H).

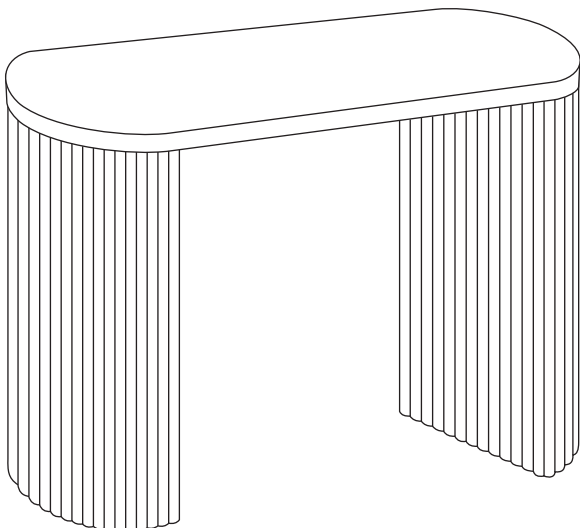

With assistance, set the table right-side up. Adjust stud as needed to level the table, if necessary.

The assembly of the table is complete.