

IMPORTANT!! PLEASE READ ENTIRE INSTRUCTION SHEET BEFORE ASSEMBLY!!

4pcs Deep Seating- Chair

Identify all parts packed in the carton against the parts list. Remove all protective materials. Place parts on a non-abrasive surface. If you are missing any parts or Are unsure how to proceed with assembly, please call customer service center

Do not attempt to assemble the product if any parts are missing or damaged.

Step 1

Place the chair back (C), chair seat(D) on a flat soft surface. Attached chair seat (D) to chair back (C) by using bolts M6 x 20mm (M) with metal washer (O).
(DO NOT TIGHTEN THE BOLTS COMPLETELY!)

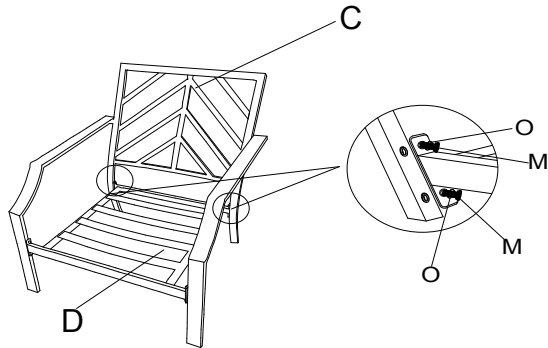

Step 1

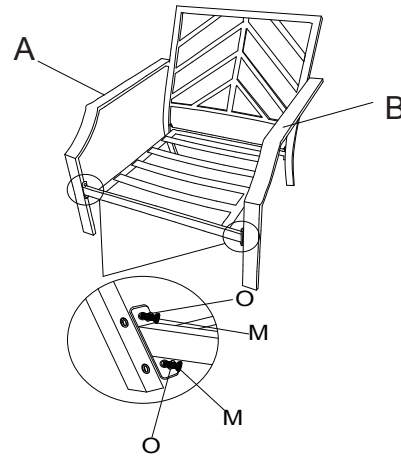

Step 2

Parts List							
A	Right Chair Arm&leg		2	B	Left Chair Arm&leg		2
C	Chair back		2	D	Chair seat		2
G	Back cushion		2	H	Seat Cushion		2
M	Bolt(M6*20)		16	N	Bolt(M6*40)		4
O	Washer		20	P	Allen wrench		1

Step 3

Attach the chair arm&leg (A&B) to the chair back(C) by using bolts(N) with metal washers(O)
(DO NOT TIGHTEN THE BOLTS COMPLETELY!).

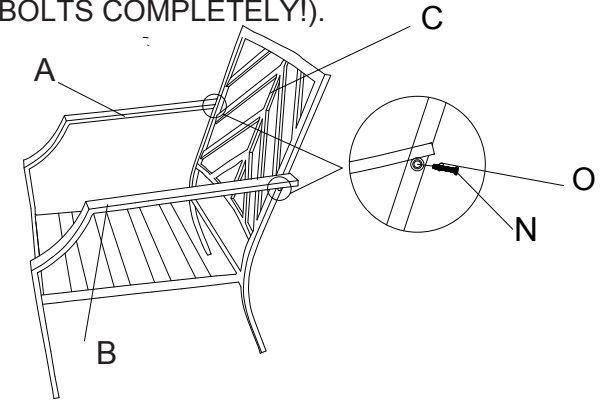

Step 4

Tighten all bolts (M&N) by using Allen wrench (P).

Step 5

Carefully turn the Chair in the upright position. Put the cushions (G & H) on the Chair
Your Chair is now ready for use.

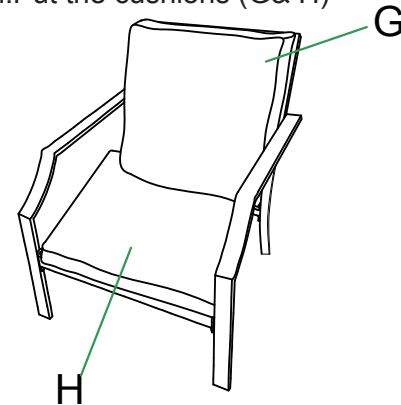







IMPORTANT!! PLEASE READ ENTIRE INSTRUCTION SHEET BEFORE ASSEMBLY!!

4PC SEATING SET-COFFEE TABLE

Identify all parts packed in the carton against the parts list. Remove all protective materials. Place parts on a non-abrasive surface. If you are missing any parts or are unsure how to proceed with assembly, please call our customer service center

Do not attempt to assemble the product if any parts are missing or damaged.

PART LIST							
NO.	Description	Sketch	Qty	NO.	Description	Sketch	Qty
I	Table top		1	J	Table connector		1
K	Table Leg		2	L	M6x15mm allen bolt		10
O	washer		10	P	Allen wrench		1

Step 1:
Place the table top(I) on a soft, flat non-abrasive surface. Attach the leg (K) to the table top(A) using M6 allen bolts (L) and M6 washers (O).

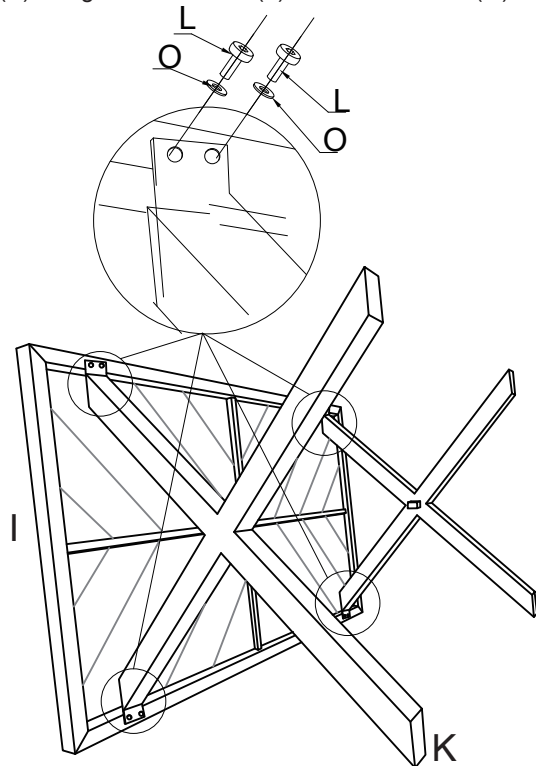

Step 2:
Attach the leg connector(J) to the leg(K) by using M6 allen bolts (L) and washers (O). Ensure all bolts are aligned and assembled correctly. Tighten all M6 bolts (L) with the wrench (P).

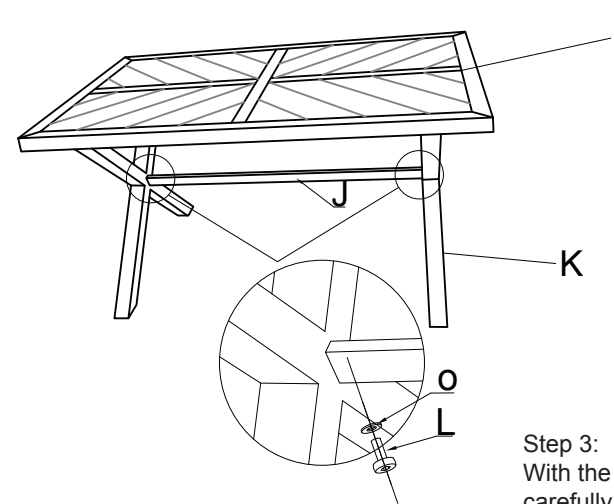

Step 3:
With the assistance of another person, carefully turn the table over right side up. The coffee table is ready for your enjoyment.

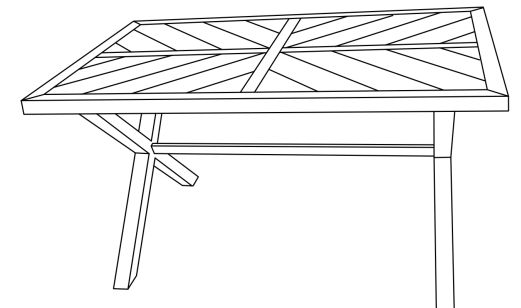

IMPORTANT!! PLEASE READ ENTIRE INSTRUCTION SHEET BEFORE ASSEMBLY!!

4pcs deep seating-Loveseat

Identify all parts packed in the carton against the parts list. Remove all protective materials. Place parts on a non-abrasive surface. If you are missing any parts or Are unsure how to proceed with assembly, please call customer service center

Do not attempt to assemble the product if any parts are missing or damaged.

Step 1
Place the loveseat seat (E), loveseat back(F) on a flat soft surface.
Attached loveseat seat (E) to loveseat back (F) by using bolts M6 x 20mm (M) with metal washer (O) .
(DO NOT TIGHTEN THE BOLTS COMPLETELY!)

Step 2:
Attached loveseat seat(E) to the loveseat arm&leg(A&B) by using bolts M6 x20mm(M) with metal washer (O).
(DO NOT TIGHTEN THE BOLTS COMPLETELY!)

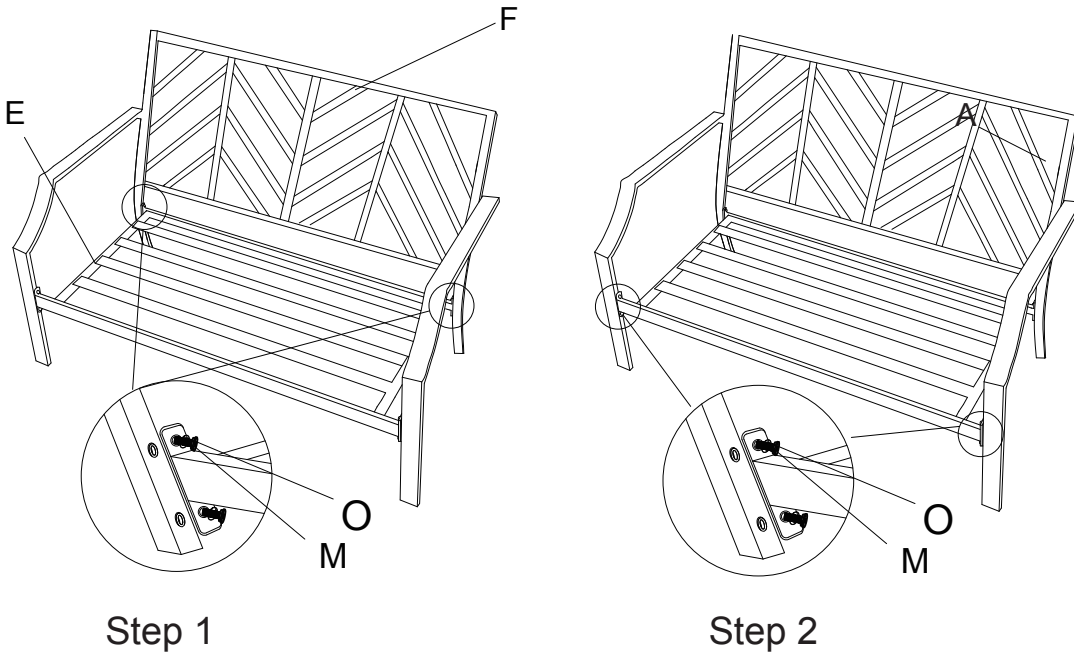

Parts List							
A	Right Loveseat Arm&leg		1	B	Left Loveseat Arm&leg		1
E	Loveseat seat		1	F	Loveseat back		1
G	Back cushion		2	H	Seat Cushion		2
M	Bolt(M6*20)		8	N	Bolt(M6*40)		2
O	Washer		10	P	Allen wrench		1

Step 3
Attach the loveseat arm&legs (A&B) to the loveseat back (F) by using bolts(N)with metal washers(O)
(DO NOT TIGHTEN THE BOLTS COMPLETELY!).

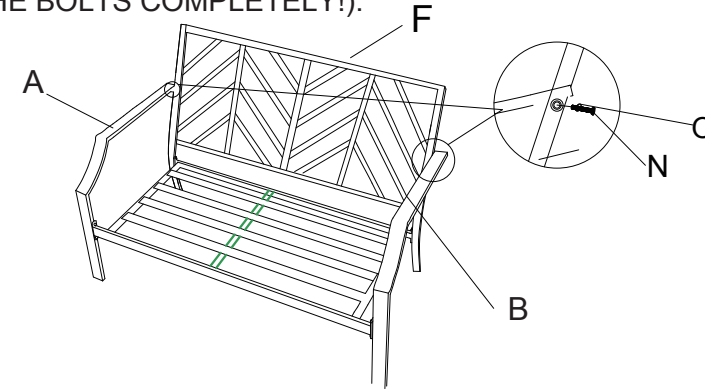

Step 4
Tighten all bolts (M&N) by using Allen wrench (P).

Step 5
Carefully turn the loveseat in the upright position. Put the cushions (G & H) on the loveseat.
Your loveseat is now ready for use.

