

# Assembly Instructions

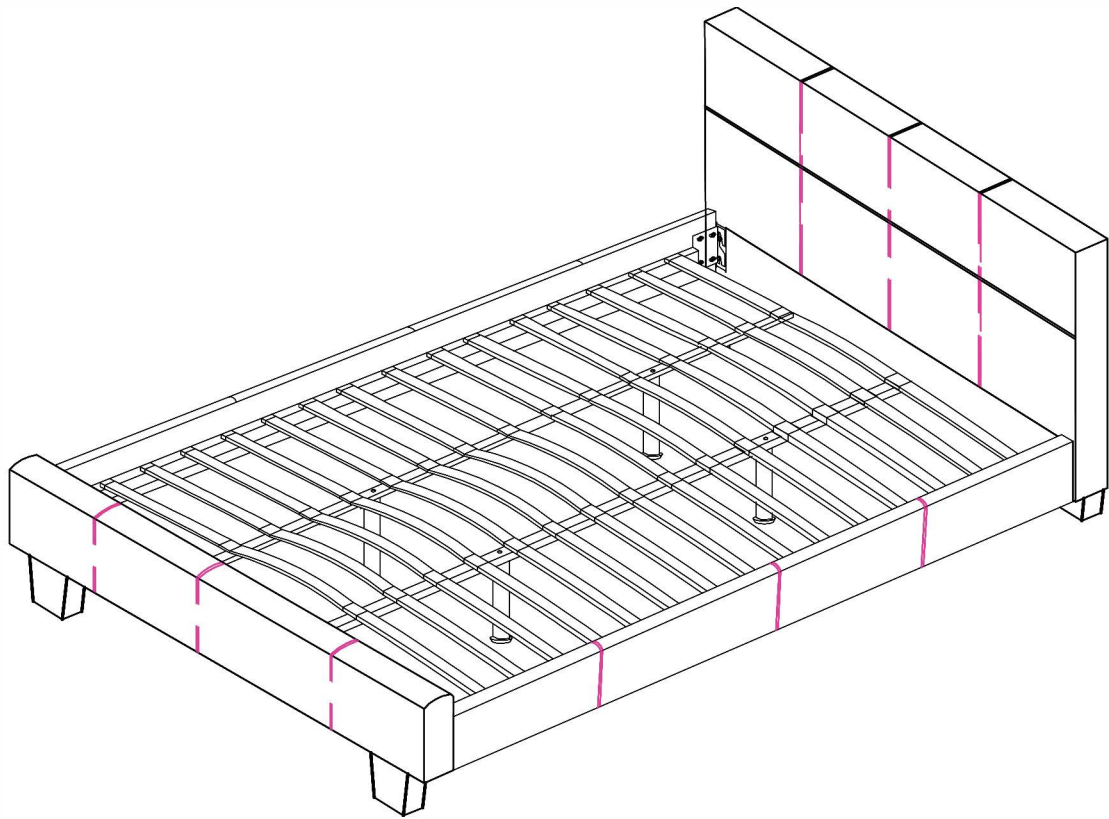

## ASSEMBLY RATING

The Assembly Rating is a 5-point system that shows the degree of effort needed in assembling a specific product (with 1 being easy and 5 being difficult). For some products, two persons are recommended.

EASY



DIFFICULT

## Tools Required For Assembly:

Allen Wrench

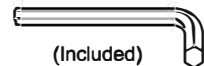

2 PERSONS RECOMMENDED

# ASSEMBLY & CARE ADVICE

FOR YOUR FURNITURE TO LAST, CORRECT ASSEMBLY AND PROPER MAINTENANCE ARE NECESSARY. PLEASE FOLLOW THE INFORMATION PROVIDED BELOW TO FULLY ENJOY YOUR FURNITURE.

## BASIC ASSEMBLY TECHNIQUES

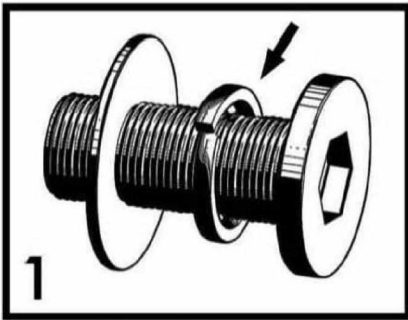

When lock or spring washer is used in an assembly, please make sure the lock or spring washer is placed between the larger flat washer and the head of the screw or bolt.

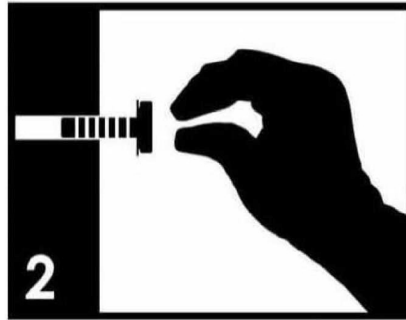

Position each part correctly and insert screws or bolts into their respective holes by hand tighten or using the proper hand tool. Only tighten when step is completed or when instructed to do so.

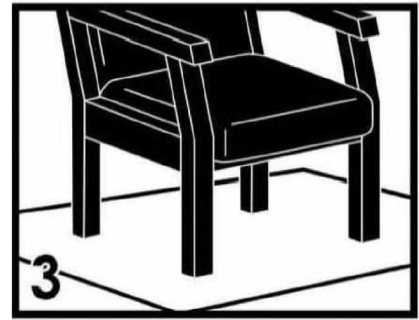

Use cardboard or carpet area when assembling furniture to prevent scratches. Make sure the furniture rests on a flat and level surface with each leg evenly touching the floor.

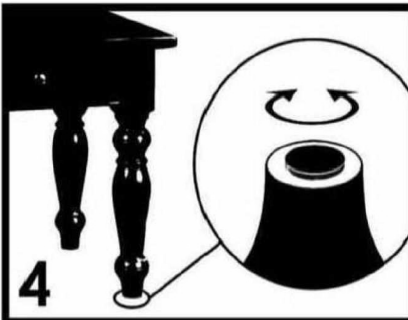

Some furniture comes with height adjustment knobs underneath each leg. To lower or to raise each leg, you need to turn clockwise or counterclockwise, respectively.

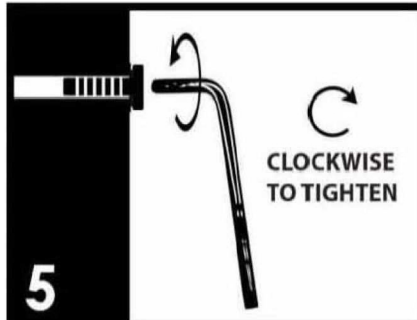

Make sure all parts are properly aligned, then use the appropriate hand tool to completely tighten the bolts or screws. Do not use power tools and do not overtighten.

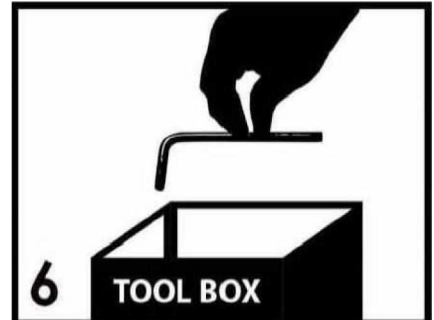

Save the instructions and store the Allen wrench or any supplied tool for later maintenance. After two weeks, check and tighten any loose hardware and repeat again every six months thereafter.

IT IS THE USER'S RESPONSIBILITY TO MAINTAIN THE FURNITURE. THE HARDWARE MAY LOOSEN OVER TIME AND MAY CAUSE THE FURNITURE TO BE WOBBLY AND UNABLE TO SUPPORT ITS INTENDED WEIGHT CAPACITY. THIS MAY LEAD TO COLLAPSE AND MAY CAUSE SERIOUS INJURY.



**FAILURE TO FOLLOW THE GUIDELINES ABOVE MAY RESULT IN INJURY AND/OR PROPERTY DAMAGE.**

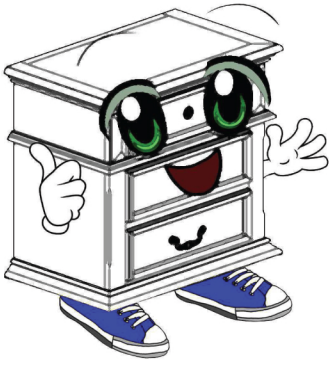

Before you begin, please read Page 2 of "Assembly and Care Advice".

And remember, do not tighten until each step is completed or instructed.

### Parts List

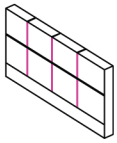

#1 x 1pc  
Headboard

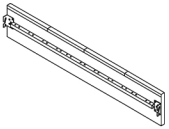

#2 x 2pcs  
Side Rail

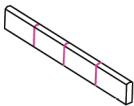

#3 x 1pc  
Footboard

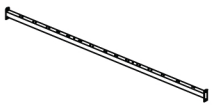

#4 x 2pcs  
Support Rail



#5 x 4pcs  
HB/FB Foot



#6 x 45pcs  
Slat



#7 x 4pcs  
Support Rail Leg

### Hardware List



#A x 8pcs  
Bolt 5/16"X1"



#B x 12pcs  
Bolt 5/16"X1-3/4"



#C x 8pcs  
Bolt 5/16"X4-3/4"



#D x 28pcs  
Flat Washer



#E x 28pcs  
Lock Washer



#F x 30pcs  
Center Connector



#G x 30pcs  
End Cap



#H x 1pc  
Allen Wrench



- I. Align the HB/FB legs to the pre-drilled holes located under the headboard (#1) and footboard (#3).
- II. Prepare 8 bolt assemblies by FIRST inserting the lock washer (#E) onto the bolt (#C) then the flat washer (#D) onto that SAME bolt (#C). Secure using the Allen wrench (#H).

#C x 8pcs  
#D x 8pcs  
#E x 8pcs

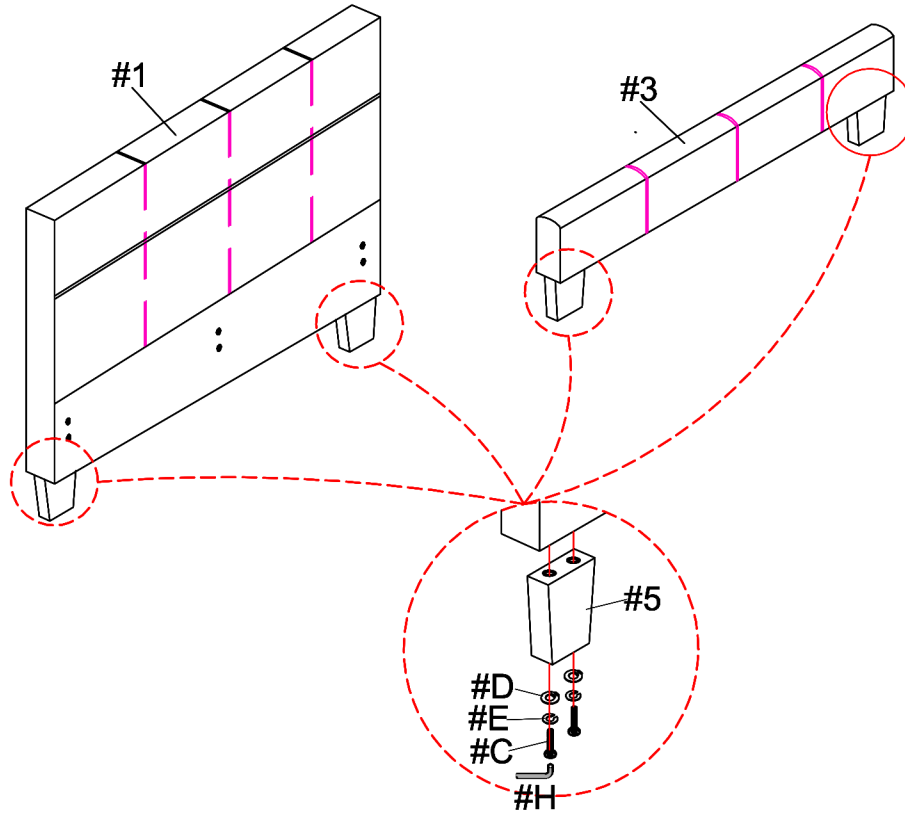

- I. Align the hooks on the side rails (#2) to the pre-drilled holes on the headboard (#1) and footboard (#3).
- II. Prepare 8 bolt assemblies by FIRST inserting the lock washer (#E) onto the bolt (#A) then the flat washer (#D) onto that SAME bolt (#A). Secure using the Allen wrench (#H).

#A x 8pcs  
#D x 8pcs  
#E x 8pcs

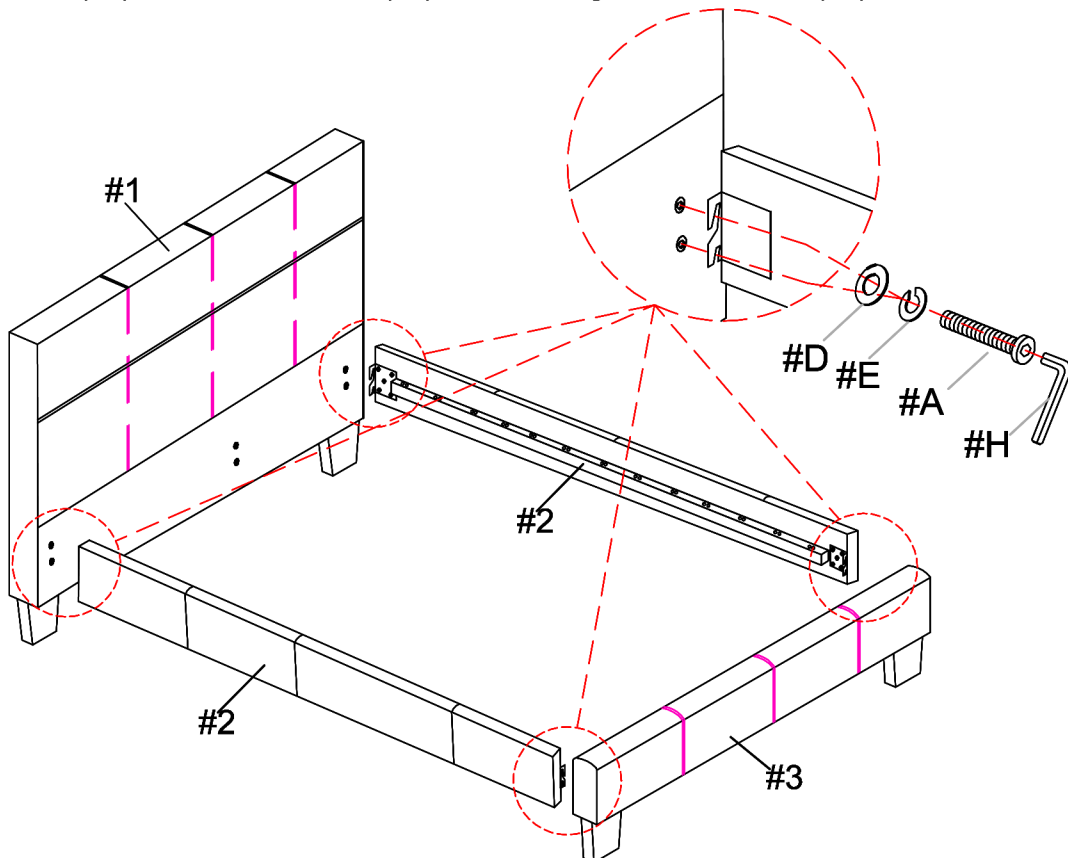



#B x 4pcs  
#D x 4pcs  
#E x 4pcs

- I. Align the support rail legs (#7) to the single pre-drilled holes on the support rail (#4).
- II. Prepare 4 bolt assemblies by FIRST inserting the lock washer (#E) onto the bolt (#B) then the flat washer (#D) onto that SAME bolt (#B). Secure using the Allen wrench (#H). Repeat process on the second support rail.

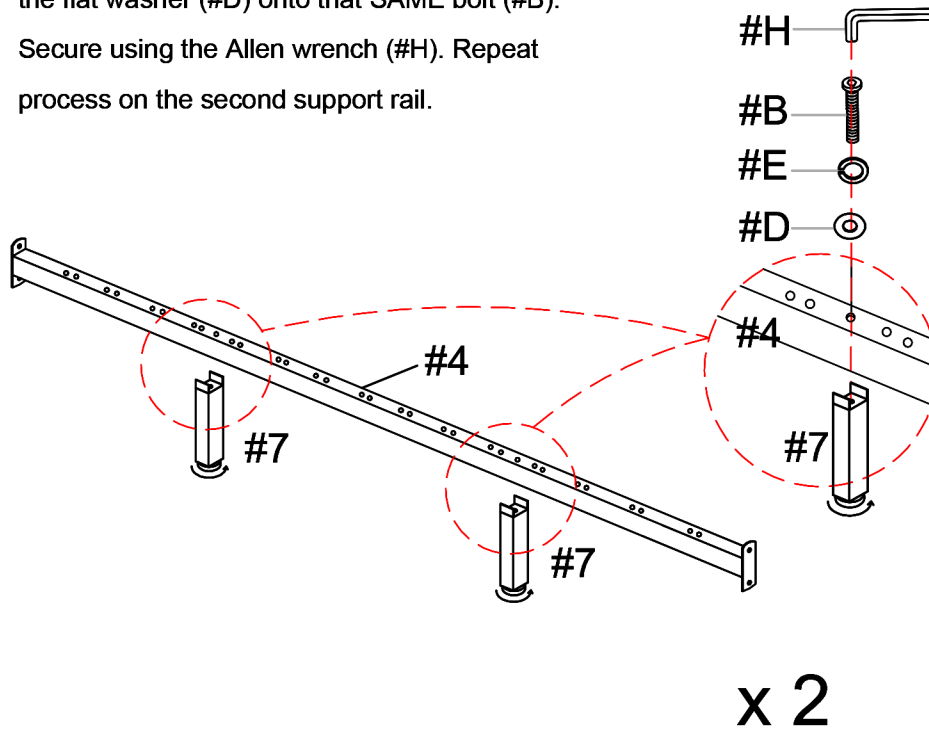

#B x 8pcs  
#D x 8pcs  
#E x 8pcs

- I. Align the support rails (#4) to the pre-drilled holes located on the center of the headboard (#1) and footboard (#3).
- II. Prepare 8 bolt assemblies by FIRST inserting the lock washer (#E) onto the bolt (#B) then the flat washer (#D) onto that SAME bolt (#B). Secure using the Allen wrench (#H). Repeat process on the second support rail.

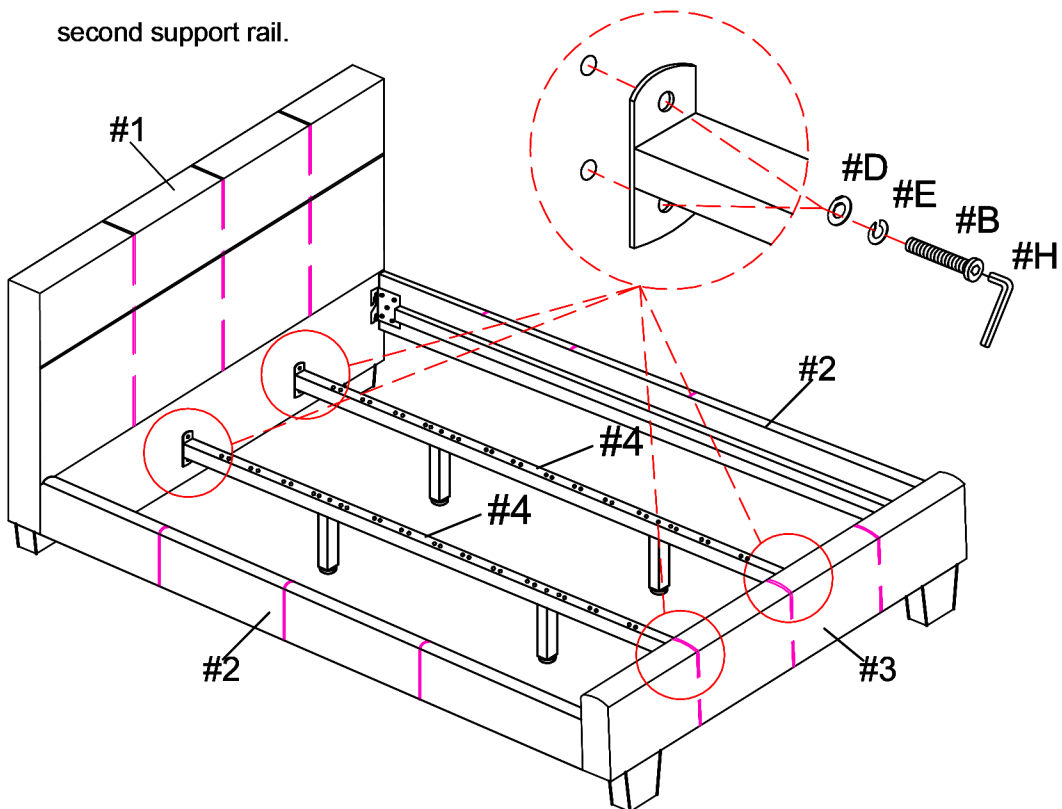



#5

Assemble slats by connecting an end cap (#G) to a slat (#6) followed by a center connector (#F) then slat (#6) another center connector (#F) then slat (#6) and finally another end cap (#G). Repeat the process for a total of 15 complete slats.

#F x 30pcs  
#G x 30pcs

Note: make sure the curved side is facing up when assembled.

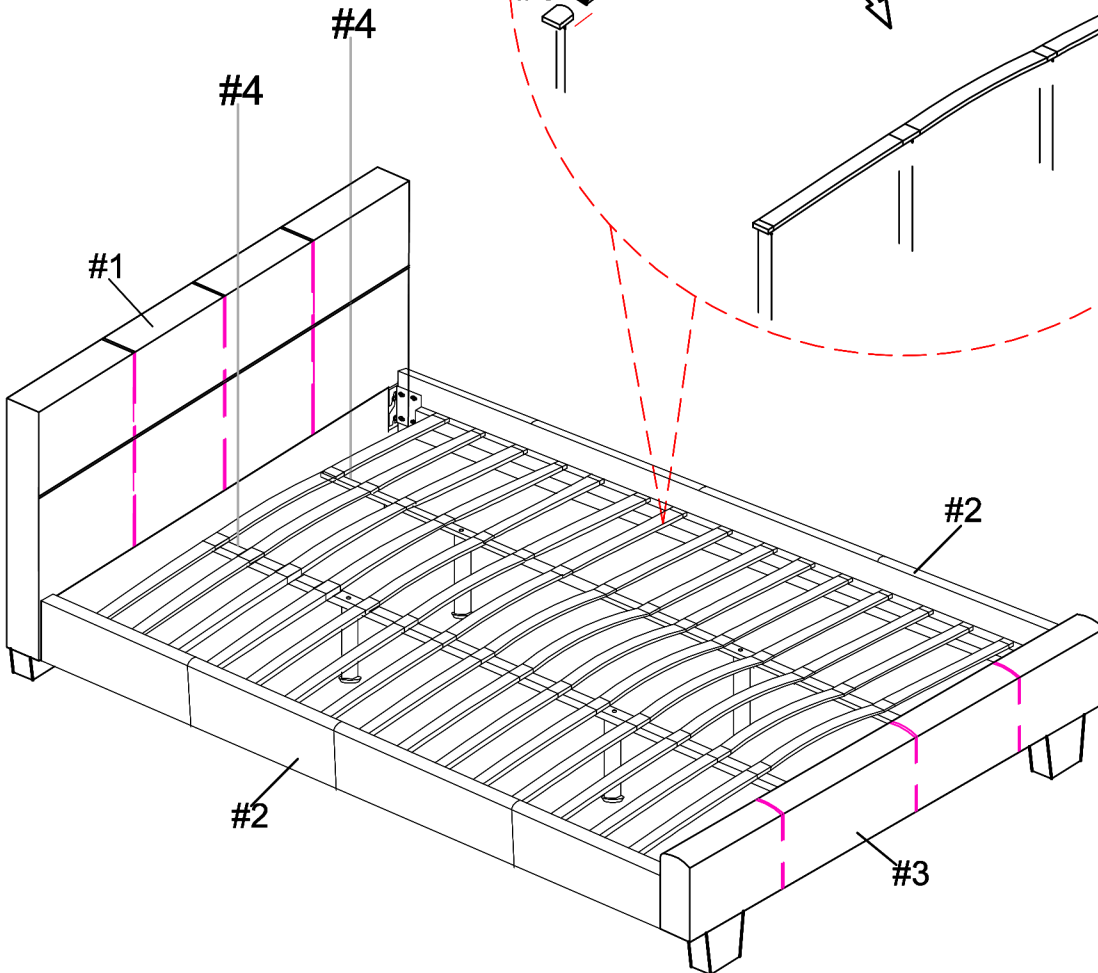
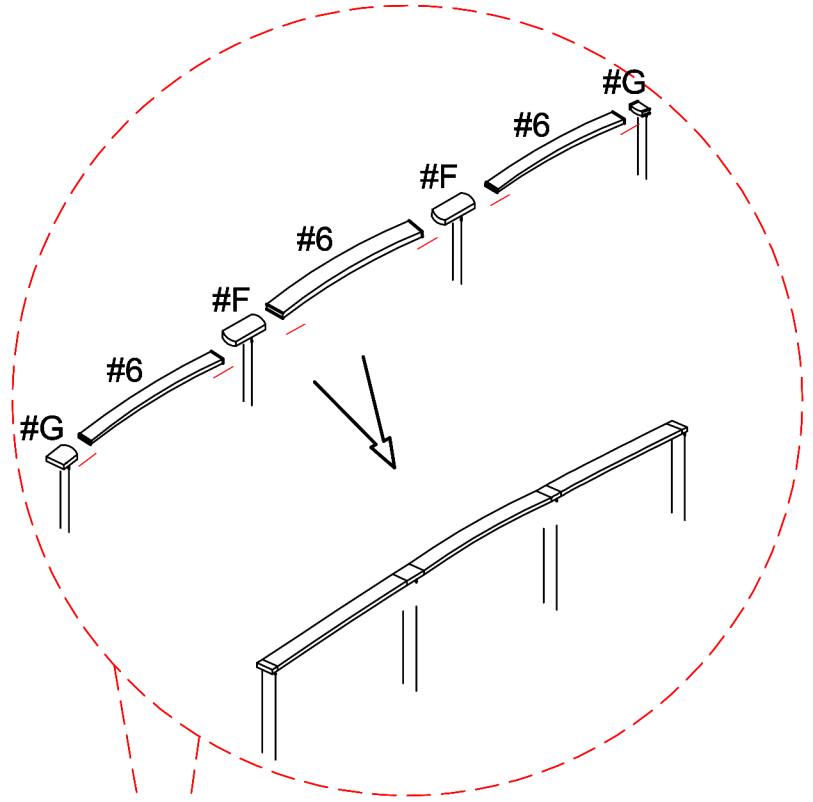

ASSEMBLY IS COMPLETED