

# ASSEMBLY INSTRUCTIONS

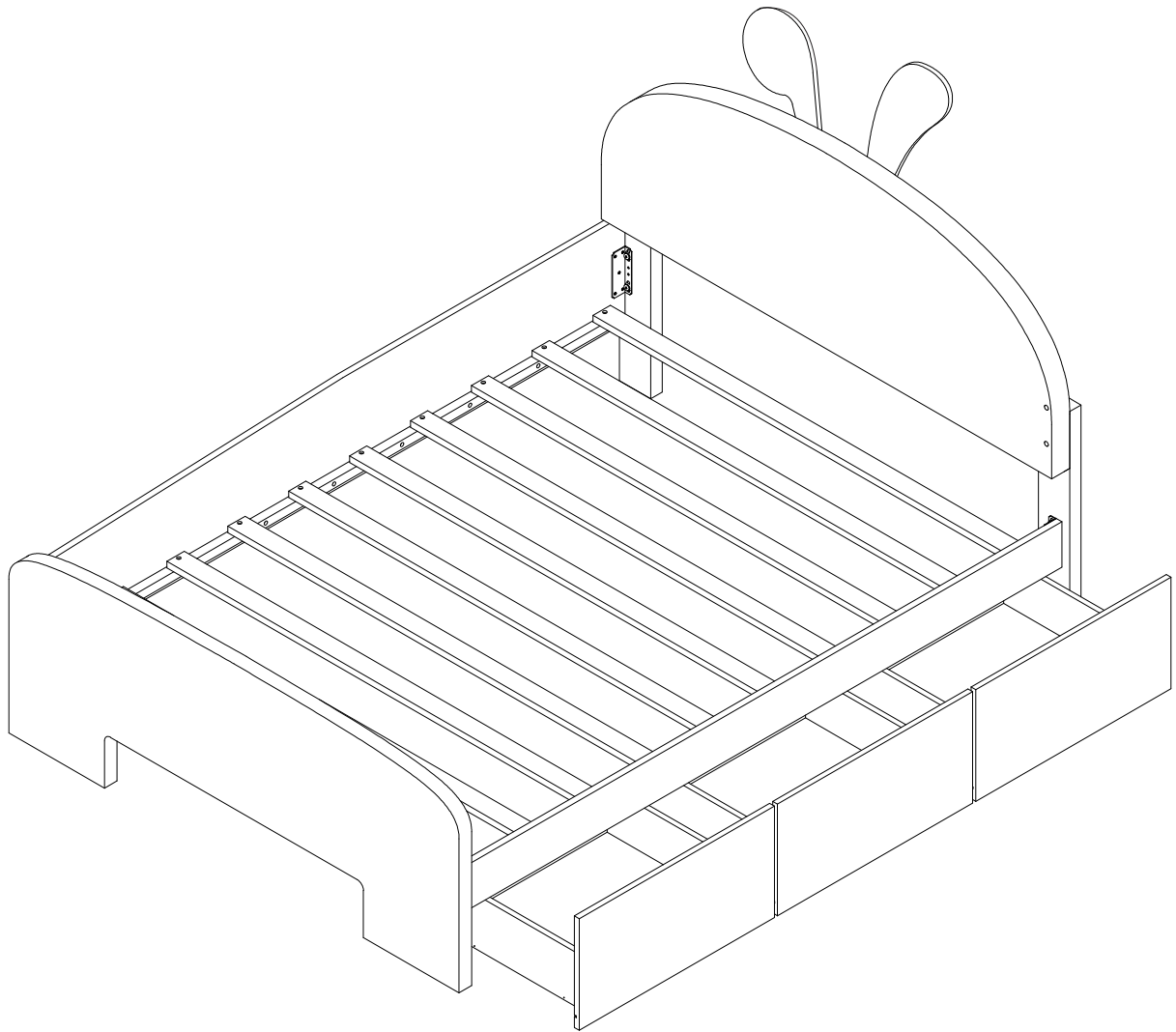

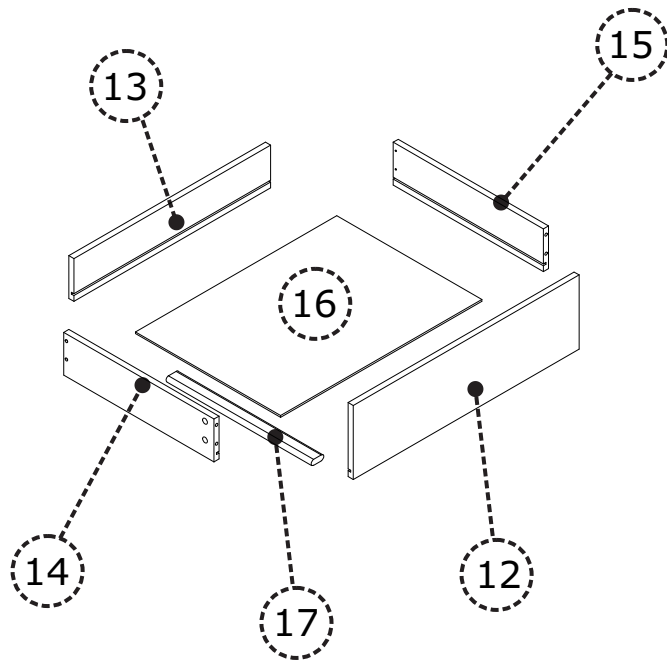
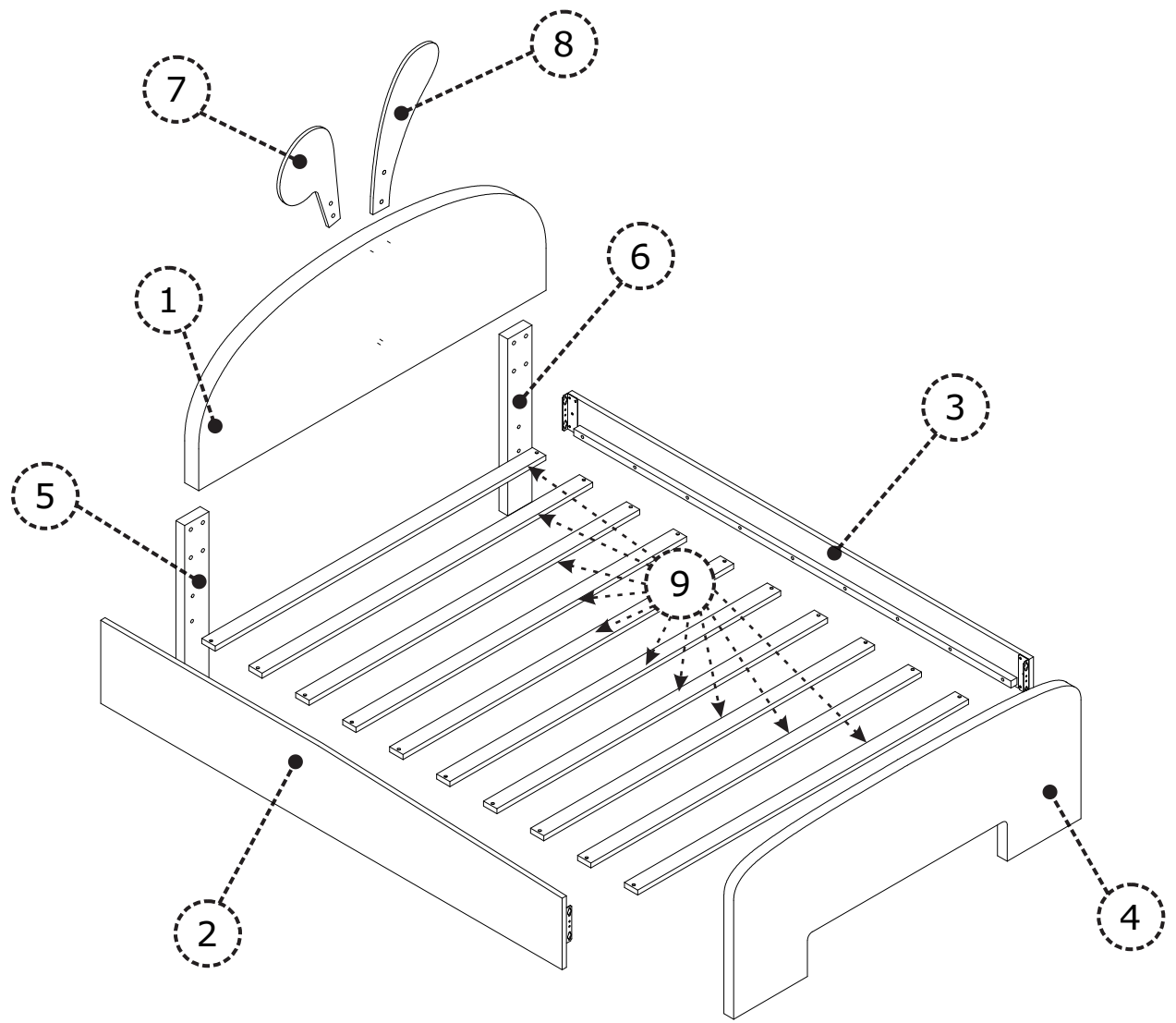

# PARTS

Check that you've received  
all parts listed below.

**BOX: 1/2**

1 x 1

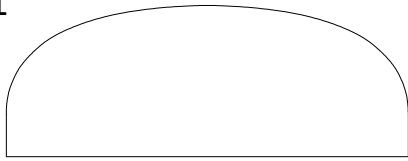

Head Board

4 x 1

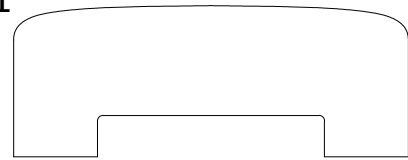

Foot Board

9 x 10



Slats

16 x 3



Bottom Drawer

17 x 3

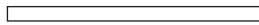

Support Drawer

Hardware

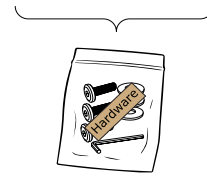

# PARTS

Check that you've received  
all parts listed below.

**BOX: 2/2**

2 x 1



Side Board Left

3 x 1



Side Board Right

5 x 1



Leg Board Left

6 x 1

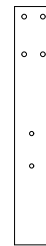

Leg Board Right

7 x 1

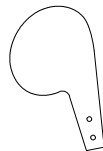

Rabbit Ear Left

8 x 1

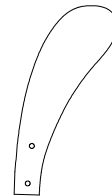

Rabbit Ear Right

12 x 3

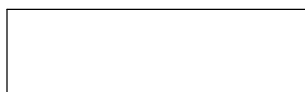

Front Drawers

13 x 3



Back Drawer

14 x 3

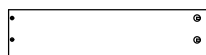

Left Drawer

15 x 3













Right Drawer

# HARDWARE

Check that you've received all hardware listed below.

## Hardware List

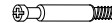
No.	OUTLOOK	DESC	QTY
(A)		<b>Bolts</b> 5/16"x30 mm	12
(B)		<b>Bolts</b> 5/16"x60 mm	8
(C)		<b>Plain washer</b> Ø19x1.5 mm	20
(D)		<b>Spring washer</b> Ø13x1 mm	20
(E)		<b>Allen key</b> 80x30x4 mm	1
(F)		<b>Screws</b> Ø4x30 mm	35
(G)		<b>Screws</b> Ø4x15 mm	54
(H)		<b>Wheel</b> 50x35x38 mm	12
(I)		<b>Steel Pat</b> 50x35x38 mm	3
(K)		<b>Cam lock</b> Ø15x13 mm	12
(L)		<b>Cam lock</b> Ø6x35 mm	12



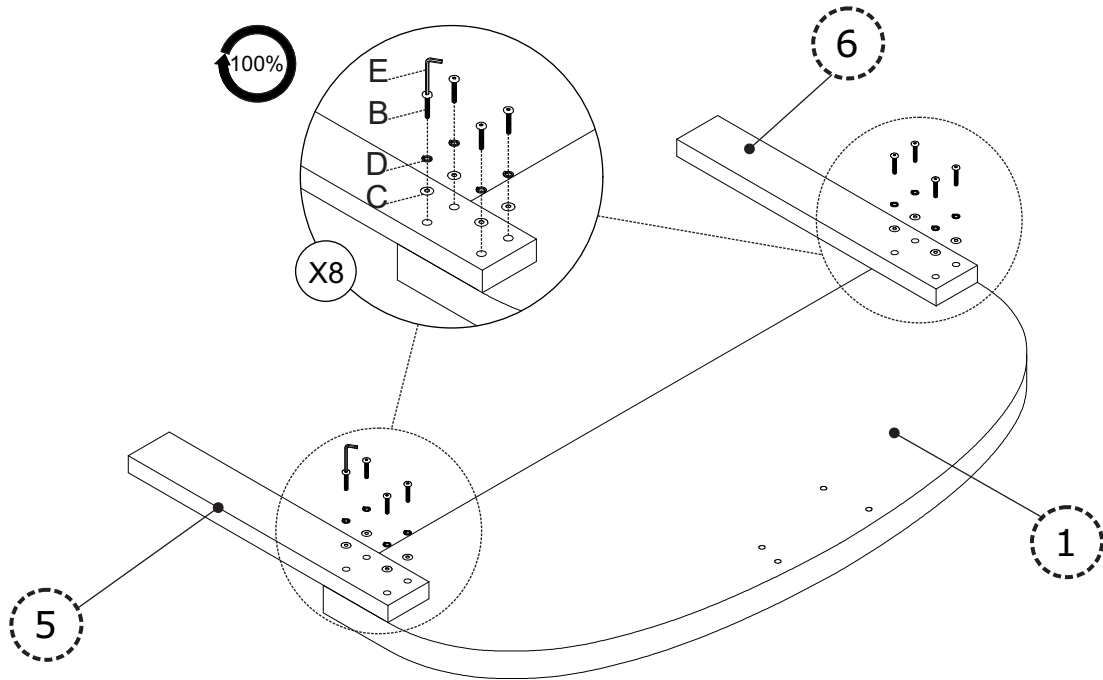
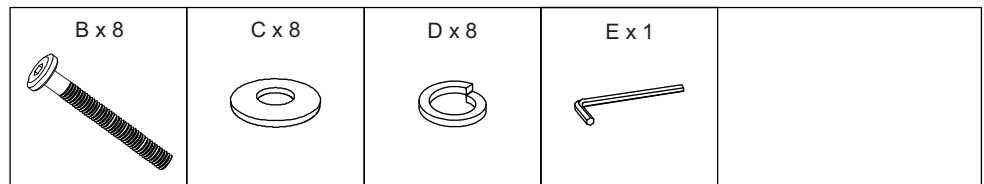

# STEP 1

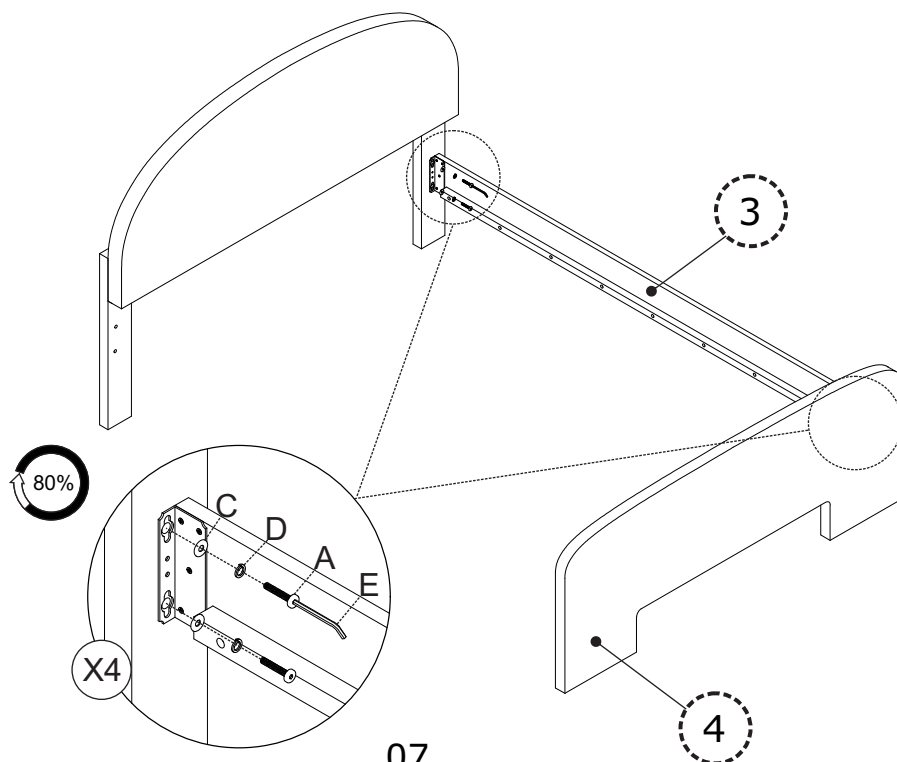
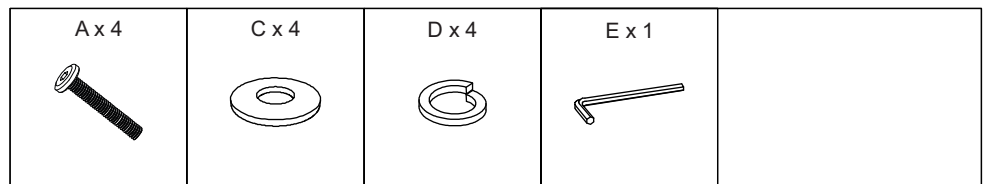

# STEP 2



# STEP 3

A x 4 	C x 4 	D x 4 	E x 1 	
--	--	--	--	--

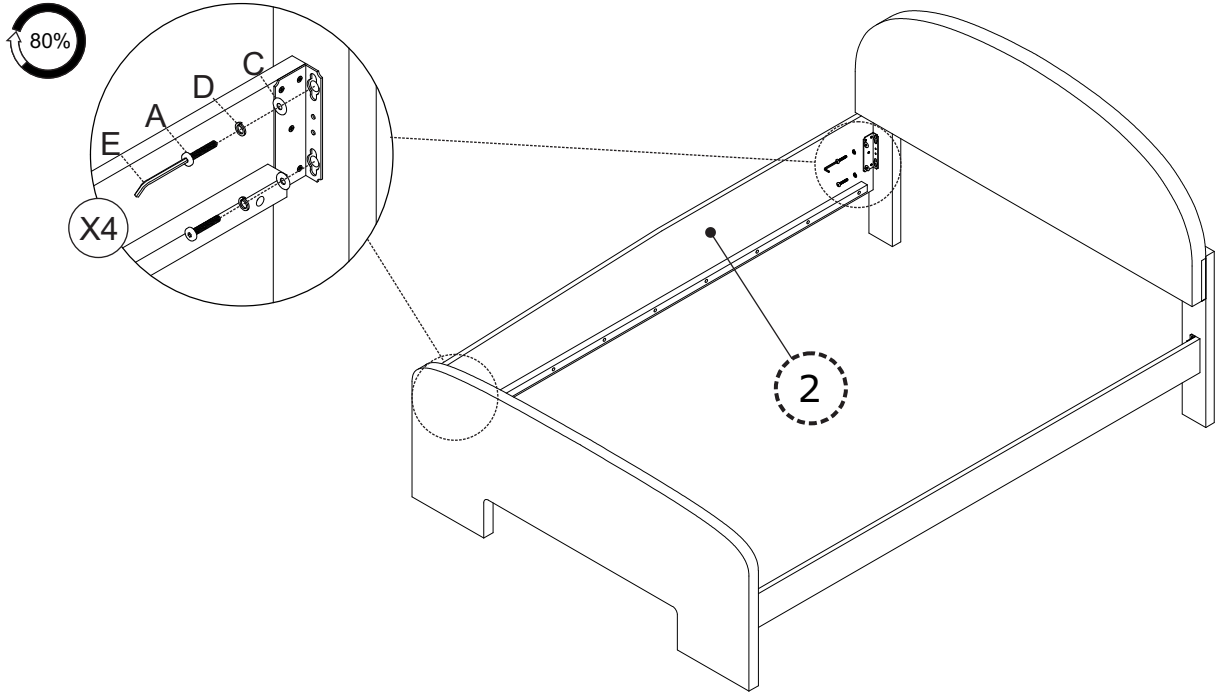

# STEP 4

E x 1 				
--	--	--	--	--

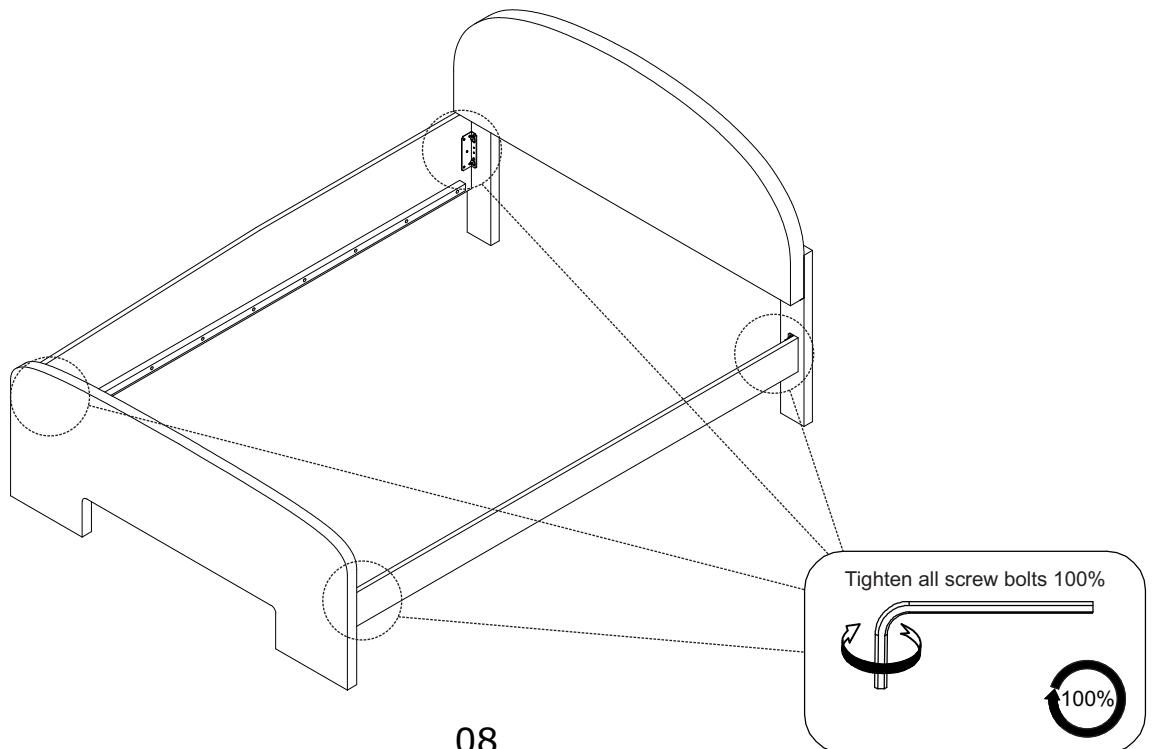

# STEP 5

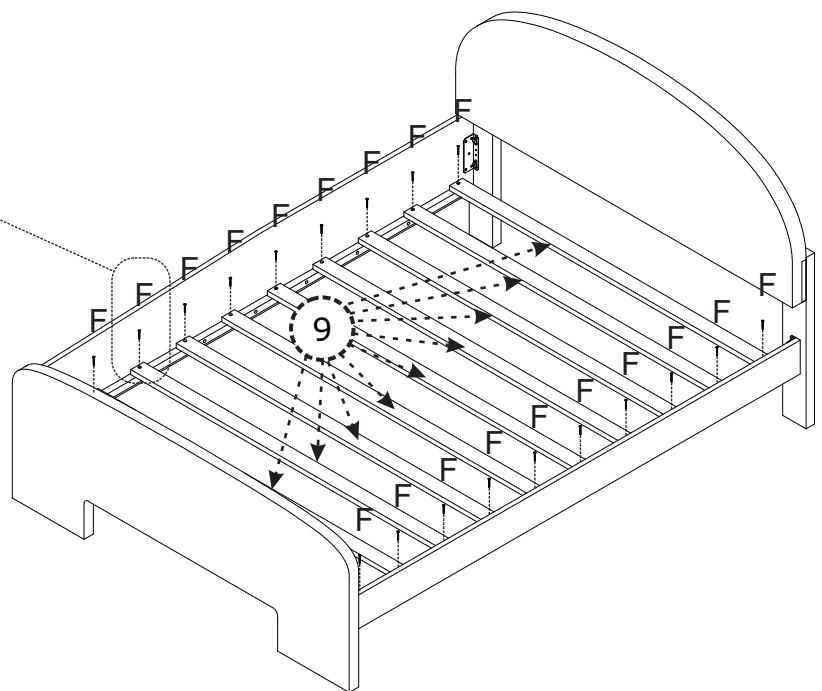
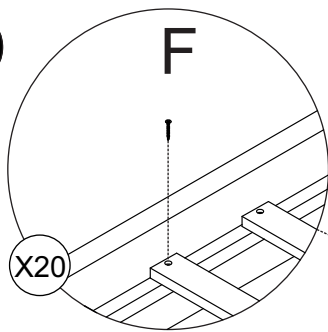
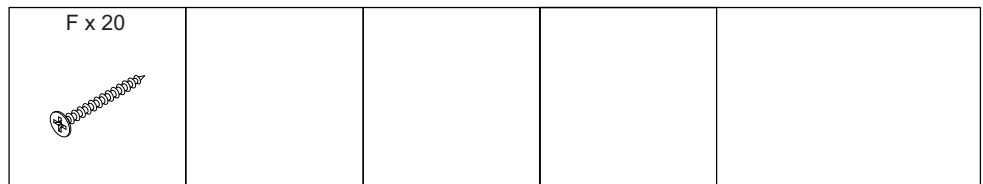

# STEP 6

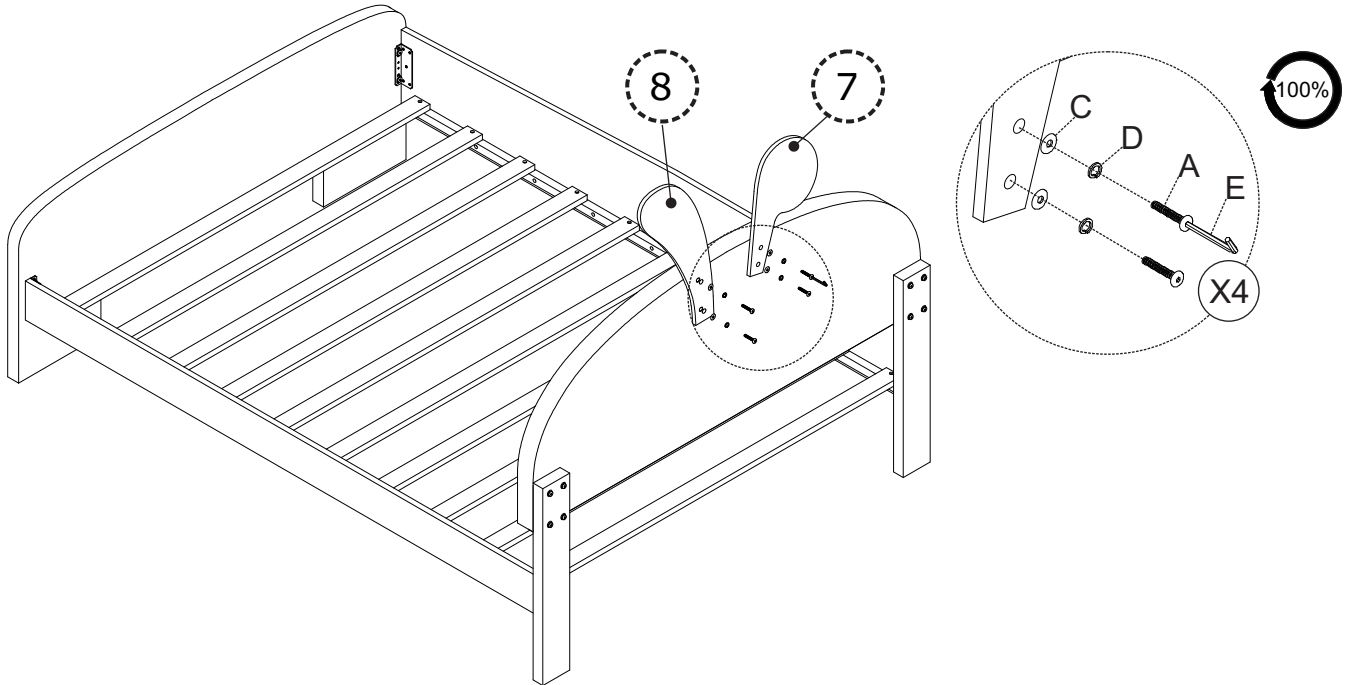
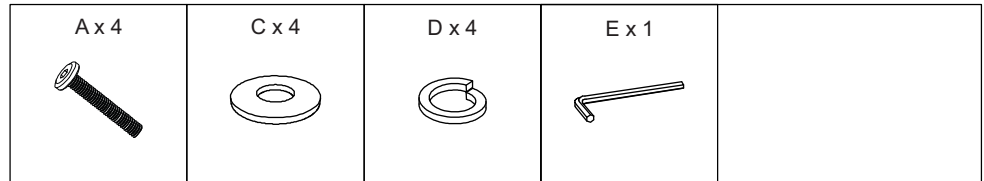

# STEP 7

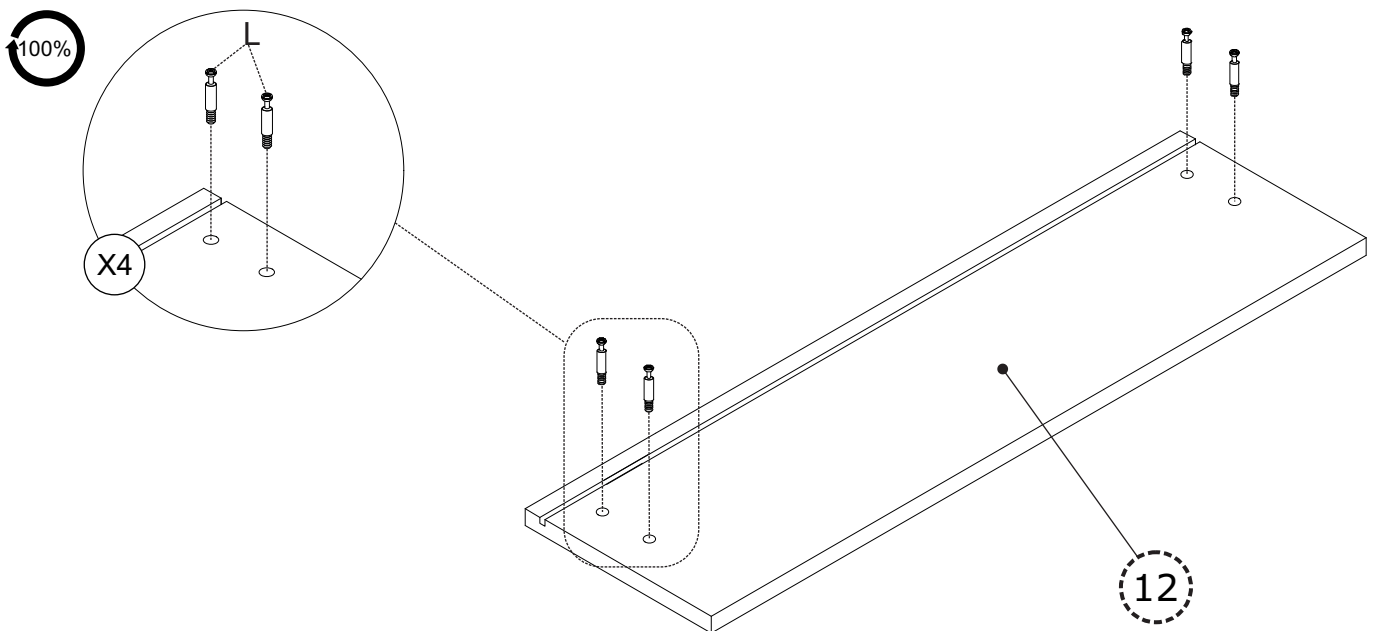
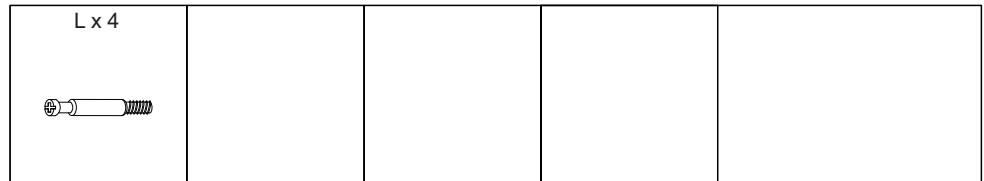

10

# STEP 8

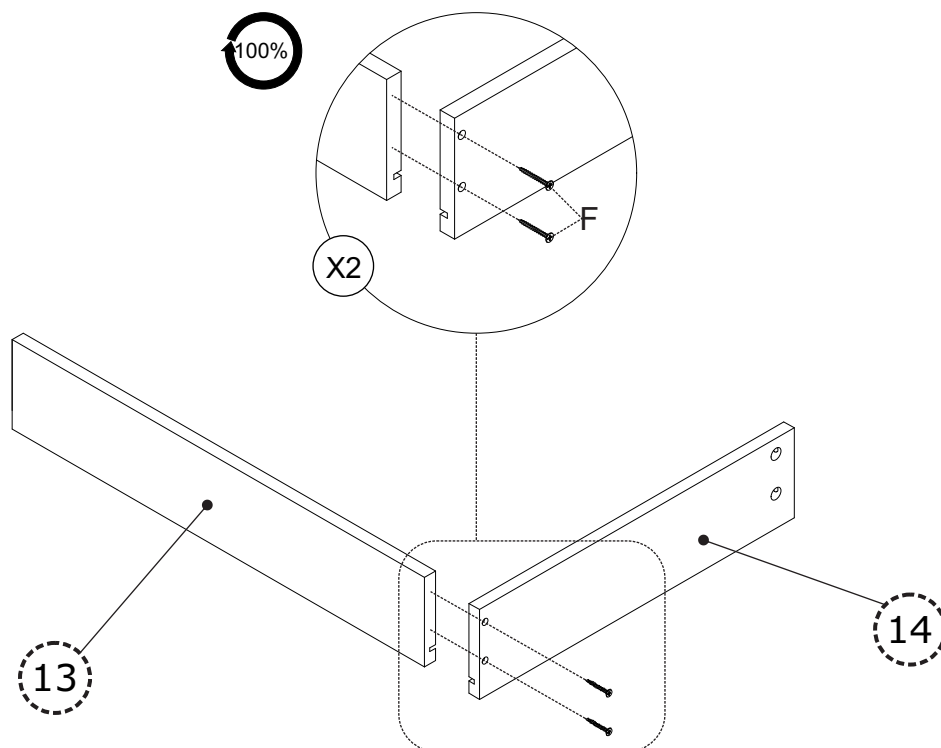
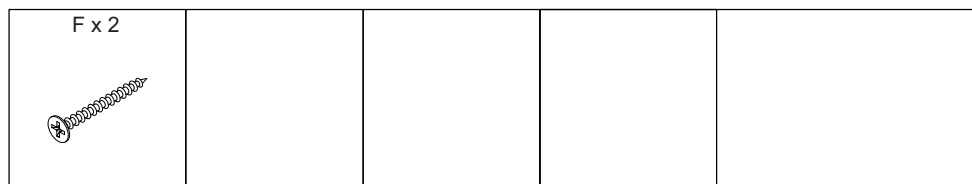

# STEP 9

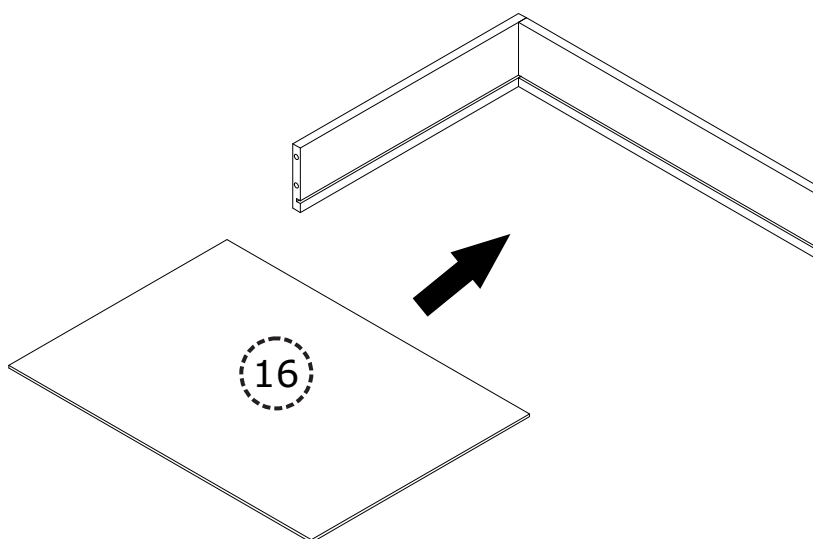
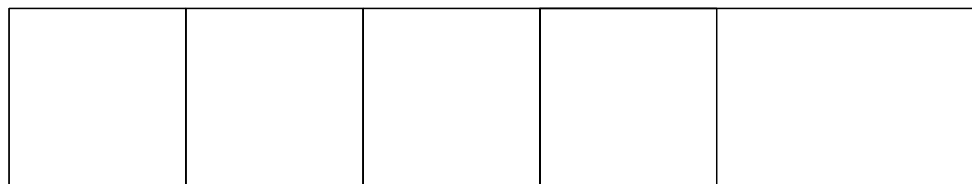

# STEP 10

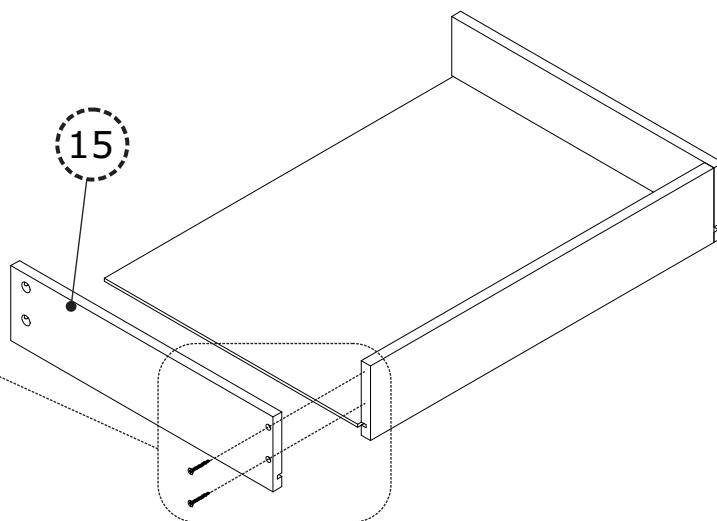
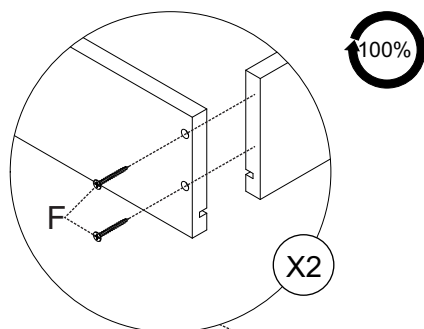
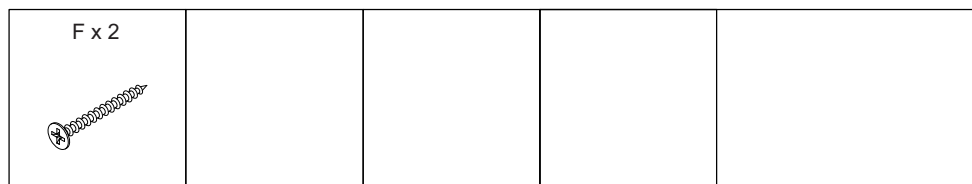

# STEP 11

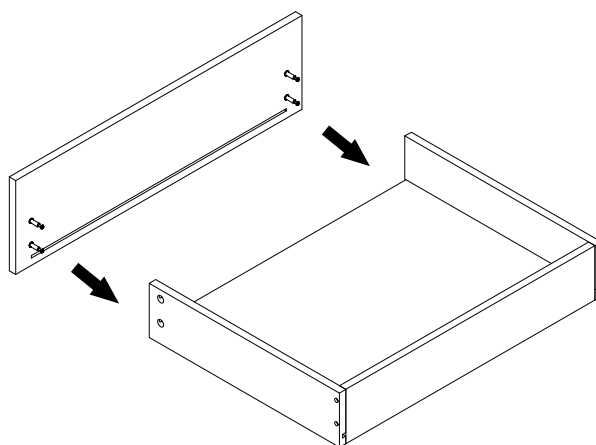
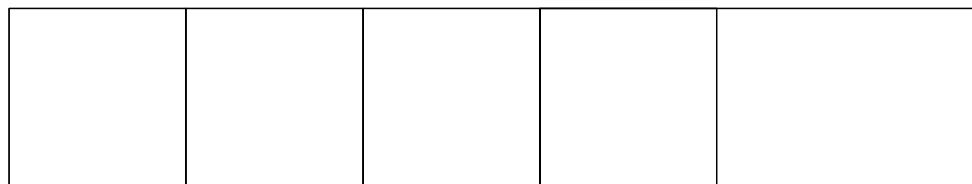

# STEP 12

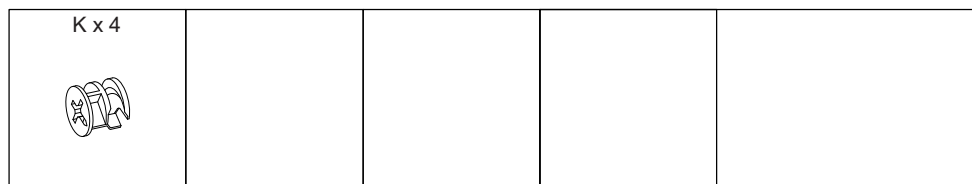

100%

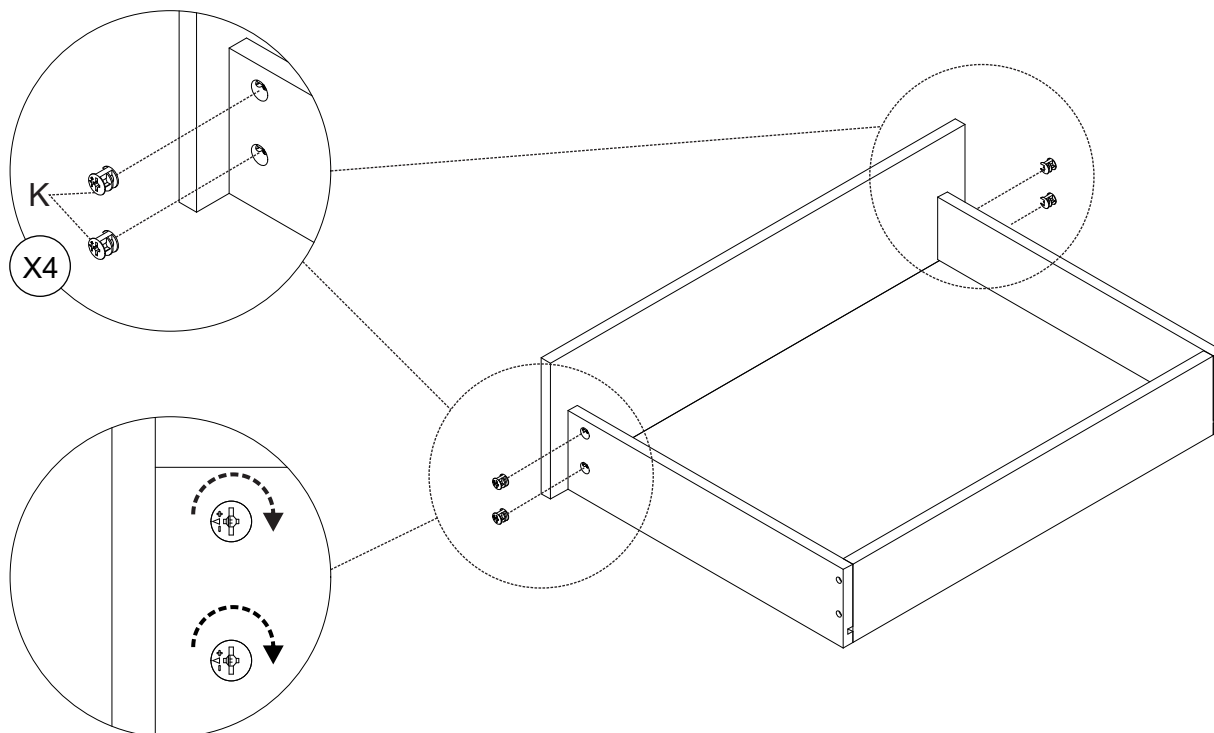

# STEP 13

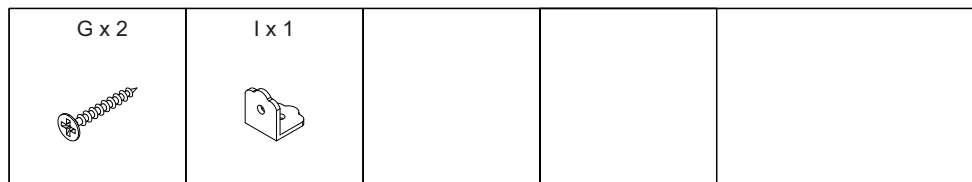

100%

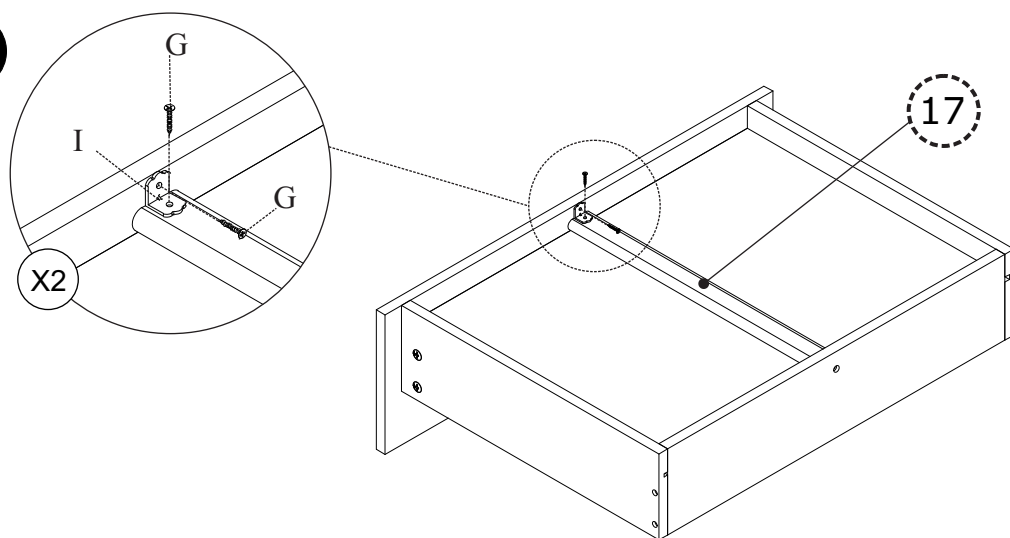

# STEP 14

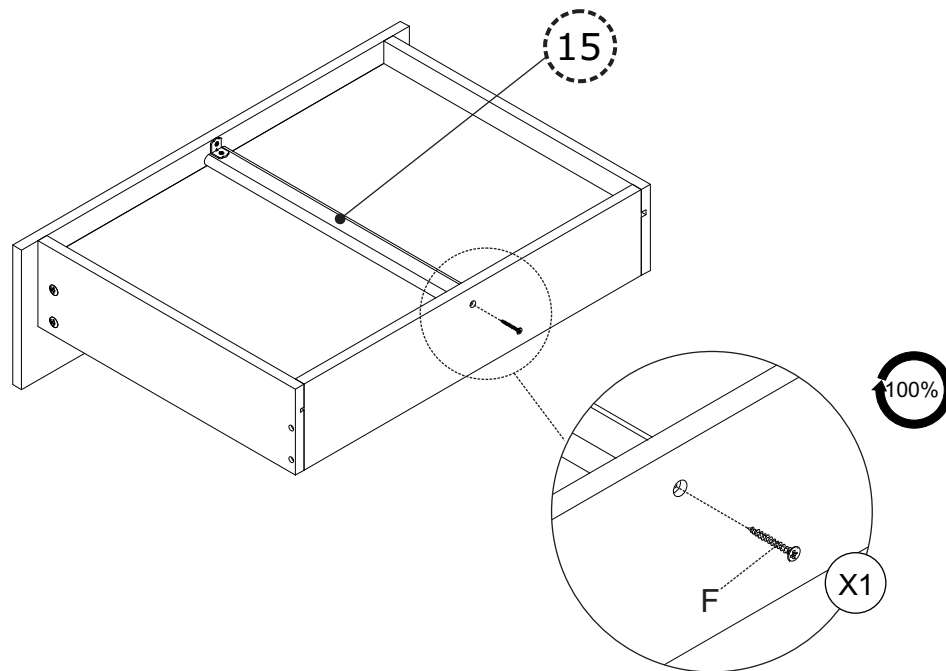
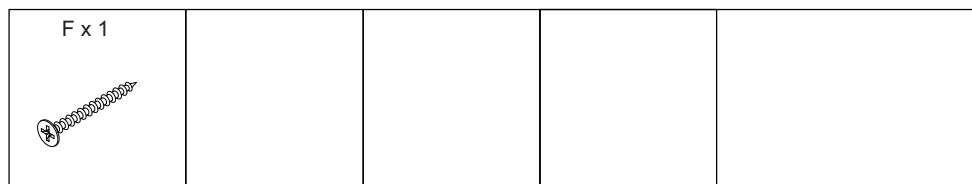

# STEP 15

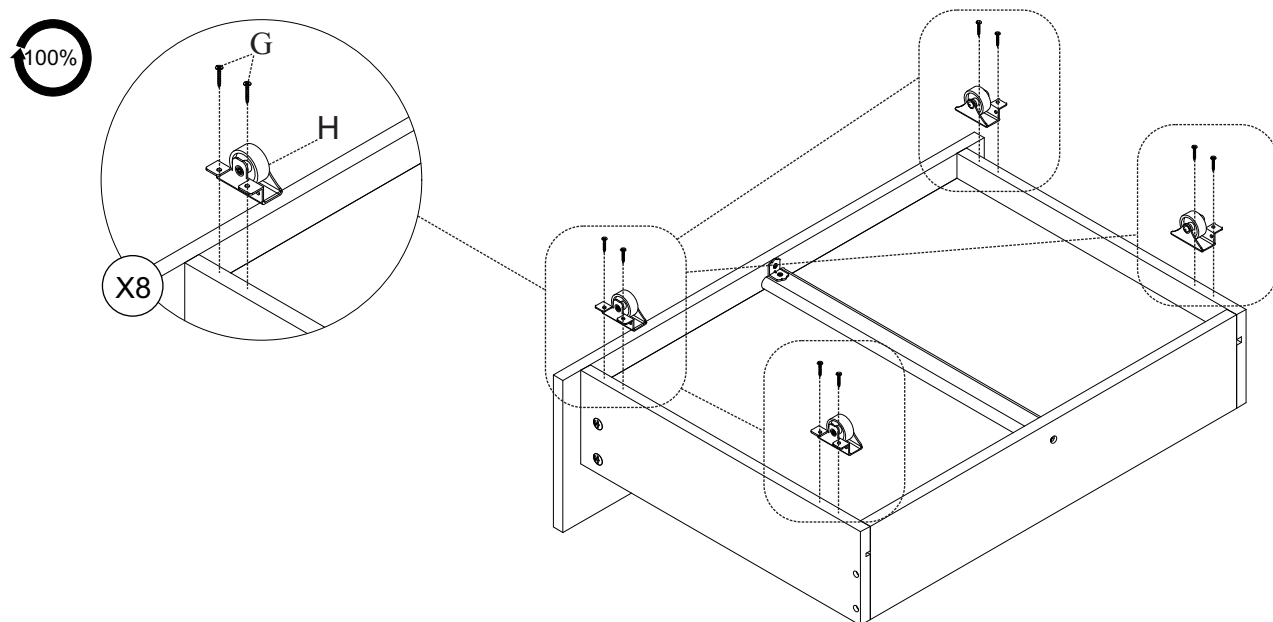
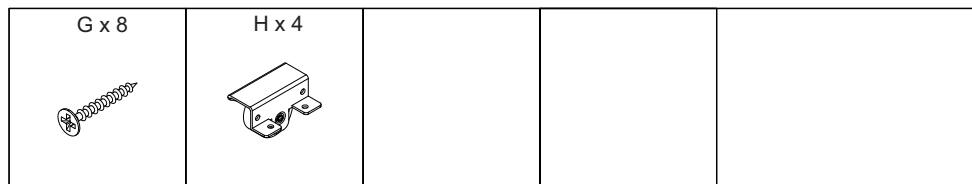

# STEP 16

