

# Installation & Assembly

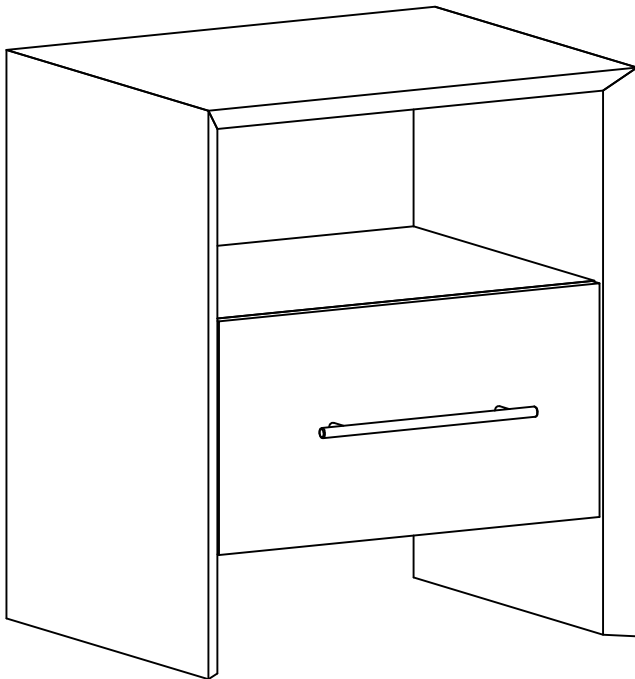

## TOOLS REQUIRED



Screwdriver  
( Not included)



(Included)  
Allen Wrench



2 - People

## ASSEMBLY RATING



EASY → DIFFICULT

The Assembly Rating is a 5-point system showing the level of effort needed to assemble a specific product.



## CHECK BEFORE STARTING

### Are you missing anything?

Double-check all parts, hardware and accessories listed on Page 6 are accounted for.

### Check out our Quick Tips!

We recommend reviewing the pre-assembly handouts. Even experts need a refresher now and then!

### Should we send any replacements?

Are there any irregularities or flaws in the parts? We can send replacements!

### Prep Time!

Please review the assembly instructions and all diagrams prior to assembling. Arrange parts as recommended on Page 7 and group identical hardware together to make assembling easier.

# PRE ASSEMBLY INTRODUCTION

We understand building ready-to-assemble furniture can be a challenging experience for some. To help avoid confusion, we have provided some helpful tips that may speed up the process.



## Teamwork

ALWAYS have at least two people to help with transporting and assembling the product to avoid potential injury and/or damage.



## Suitable Location

Assembling near the area of the intended location is highly recommended.



## Sufficient Space

Make sure you have enough space to move around during the assembly.



## Avoid Scratches

Use cardboard, blankets or a carpeted area while assembling furniture to prevent to prevent scratches and damages.



## Flat Surface

Make sure the furniture rests on a flat and level surface with each leg evenly touching the floor.

# ASSEMBLY AND CARE ADVICE



**FAILURE TO FOLLOW THE GUIDELINES BELOW MAY RESULT IN INJURY AND/OR PROPERTY DAMAGE.**



Position each part correctly and insert screws or bolts into their respective holes.



Turn clockwise to tighten and only tighten when step is completed or when instructed to do so.



Use the appropriate hand tools or power tools for assembly. Select steps, such as tightening screws and/or bolts, may require hand tools to avoid causing damage during assembly.



Save the instructions and store any supplied tools for later maintenance.



After two weeks, check and tighten any loose hardware and repeat again every six months thereafter.

**IT IS THE USER'S RESPONSIBILITY TO MAINTAIN THE FURNITURE. THE HARDWARE MAY LOOSEN OVER TIME AND MAY CAUSE THE FURNITURE TO BE WOBBLY AND UNABLE TO SUPPORT ITS INTENDED WEIGHT CAPACITY. THIS MAY LEAD TO COLLAPSE AND MAY CAUSE SERIOUS INJURY.**

# CAMLOCK FASTENER ASSEMBLY INSTRUCTIONS

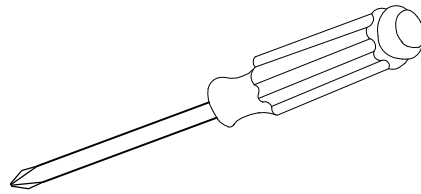
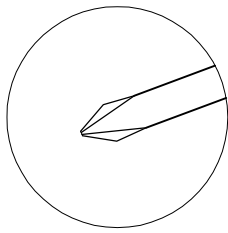

Note: Every cam lock bolt must have a cam lock connector in order to fasten the parts together.

- (1) **Secure the threaded end of the cam bolt by using a screwdriver.**

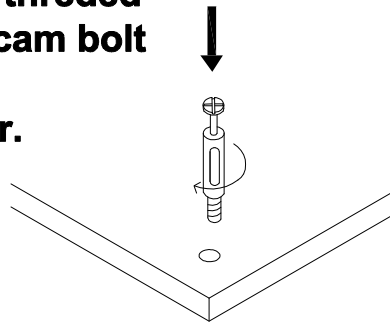

Turn right (clockwise) to tighten.

**Align the cam connector with its side opening (or arrow) pointing to the small drilled hole.**

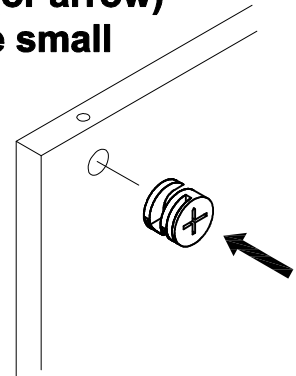

- (2) **Insert the cam lock bolt into the pre-drilled hole above the cam connector.**

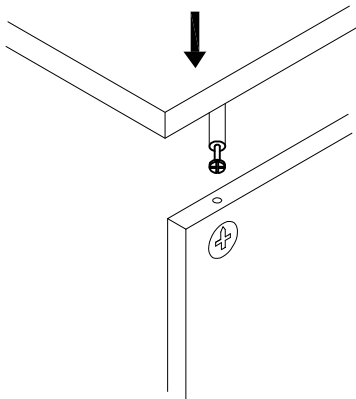

- (3) **Two parts should fit snugly against each other.**

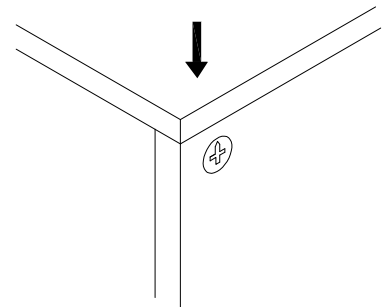

- (4) **Turn right (clockwise) to tighten.**

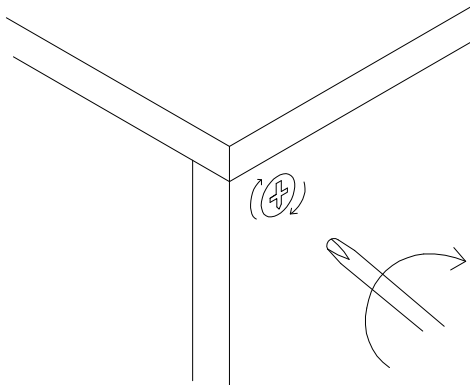

**Turn the cam connector with a screwdriver until it will not turn any more with light to moderate force.**



# END TABLE



- Please keep instructions for future reference.
- Check the quantity and irregularity of parts and hardware before you start.

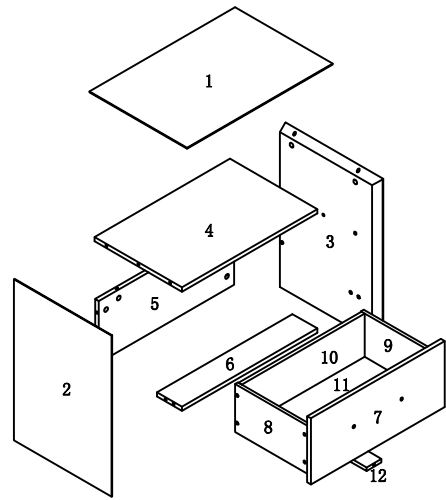

## PARTS

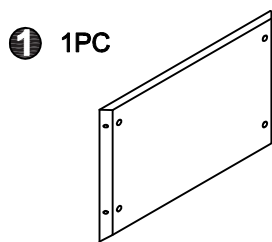

① 1PC

TOP

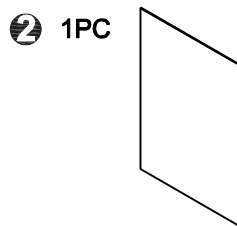

② 1PC

LEFT SIDE PANEL

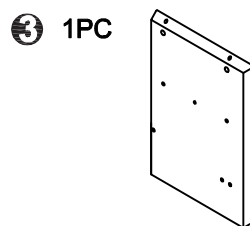

③ 1PC

RIGHT SIDE PANEL

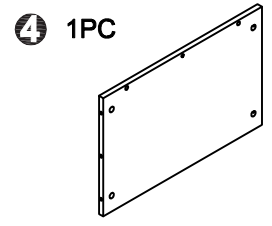

④ 1PC

LAYER PLATE

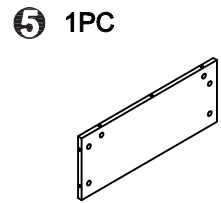

⑤ 1PC

BACK PANEL

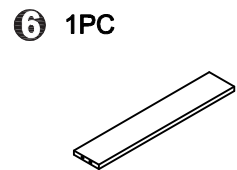

⑥ 1PC

BOTTOM BRACE

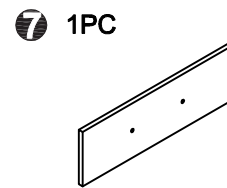

⑦ 1PC

DRAWER FRONT PANEL

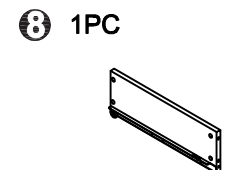

⑧ 1PC

DRAWER LEFT SIDE PANEL

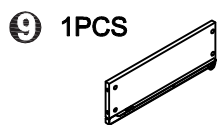

⑨ 1PCS

DRAWER RIGHT SIDE PANEL

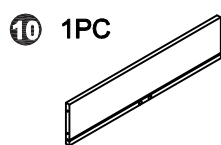

⑩ 1PC

DRAWER BACK PANEL

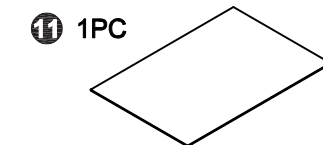

⑪ 1PC

DRAWER BOTTOM PANEL

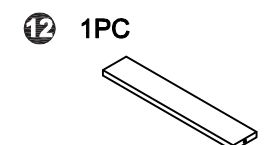

⑫ 1PC

DRAWER BOTTOM SUPPORT

# HARDWARE

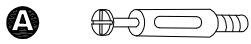

**A**  
CAMBOLT  
L29 14PCS



**B**  
CAMLOCK L  
Ø15 22PCS

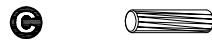

**C**  
DOWEL  
Ø8X25 3PCS



**D**  
STICKER  
Ø22 8PCS

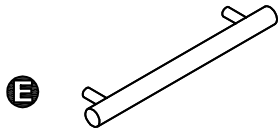

**E**  
HANDEL  
#192 1PC

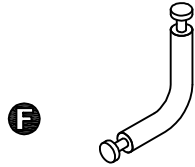

**F**  
DOUBLE SCREW  
4PCS

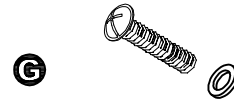

**G**  
SMALL SCREW  
Ø4X22 2PCS

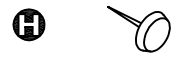

**H**  
SHACKLES  
Ø16 4PCS



**I**  
SMALL CAMBOLT  
L20 5PCS



**J**  
SMALL CAMLOCK L  
Ø12 5PCS



**K**  
SMALL SCREW  
Ø4X30 6PCS



**L**  
STICKER  
Ø15 4PCS

# ASSEMBLY INSTRUCTIONS

# 1

HARDWARE **A** X2PCS

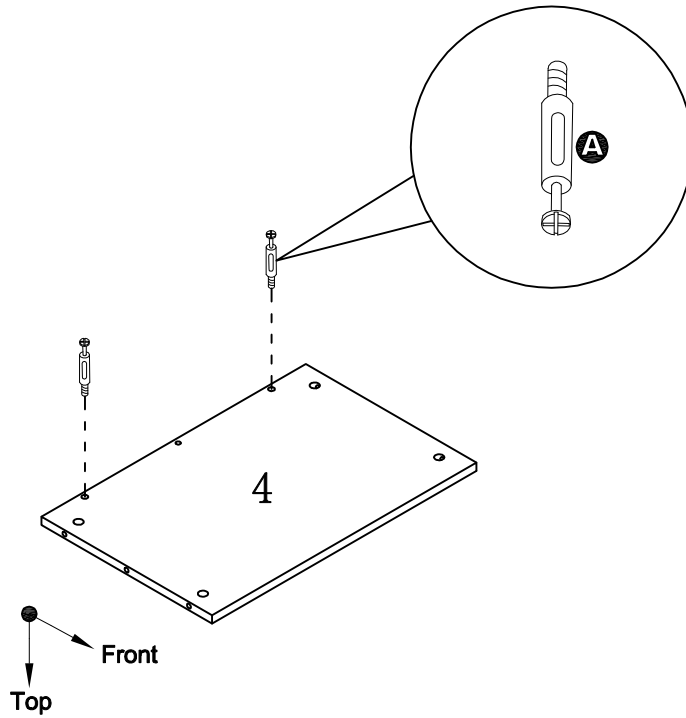

# 2

HARDWARE **B** X 2PCS

HARDWARE **C** X 1PC

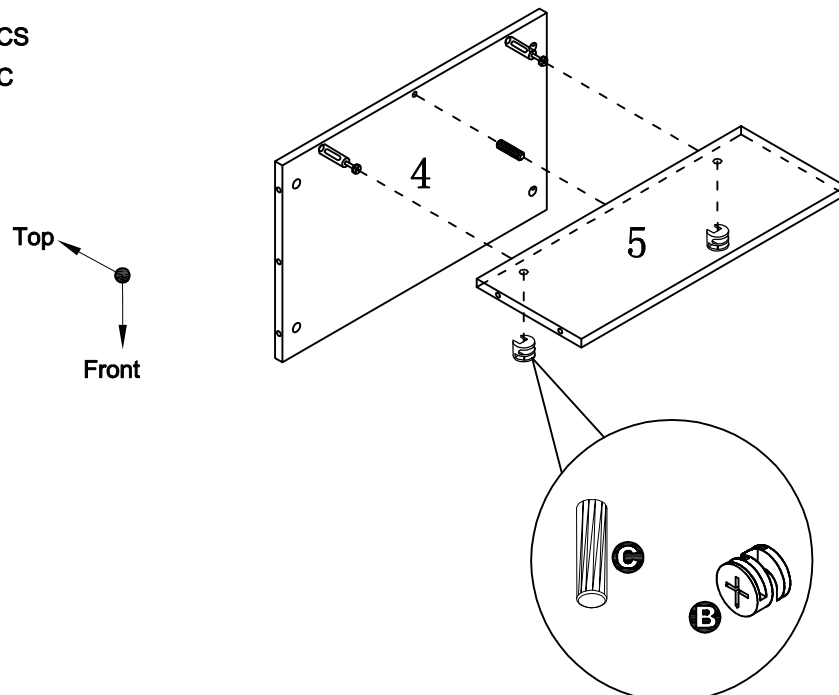

# ASSEMBLY INSTRUCTIONS

## 3

HARDWARE **A** X 6PCS

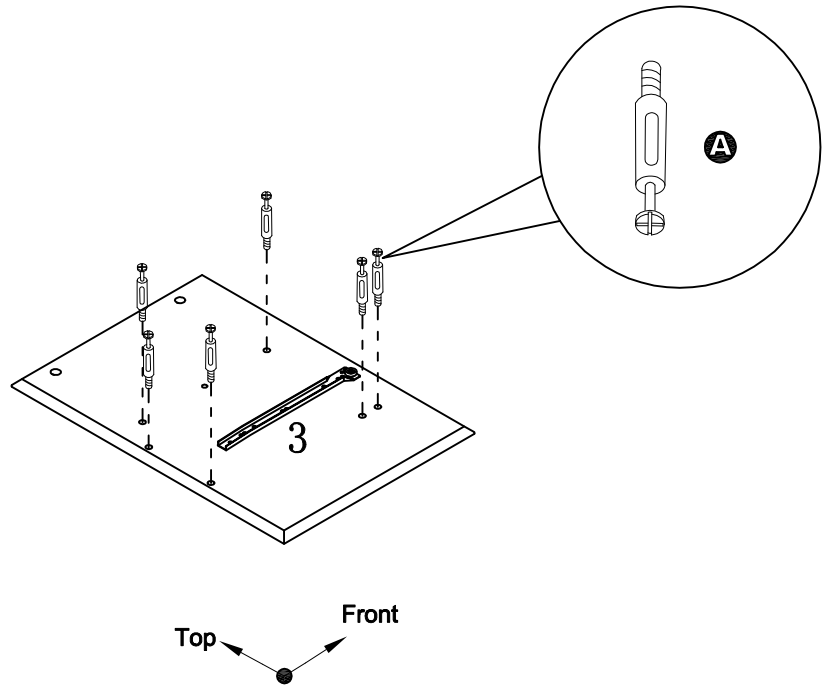

## 4

HARDWARE **B** X 4PCS

HARDWARE **C** X 1PC

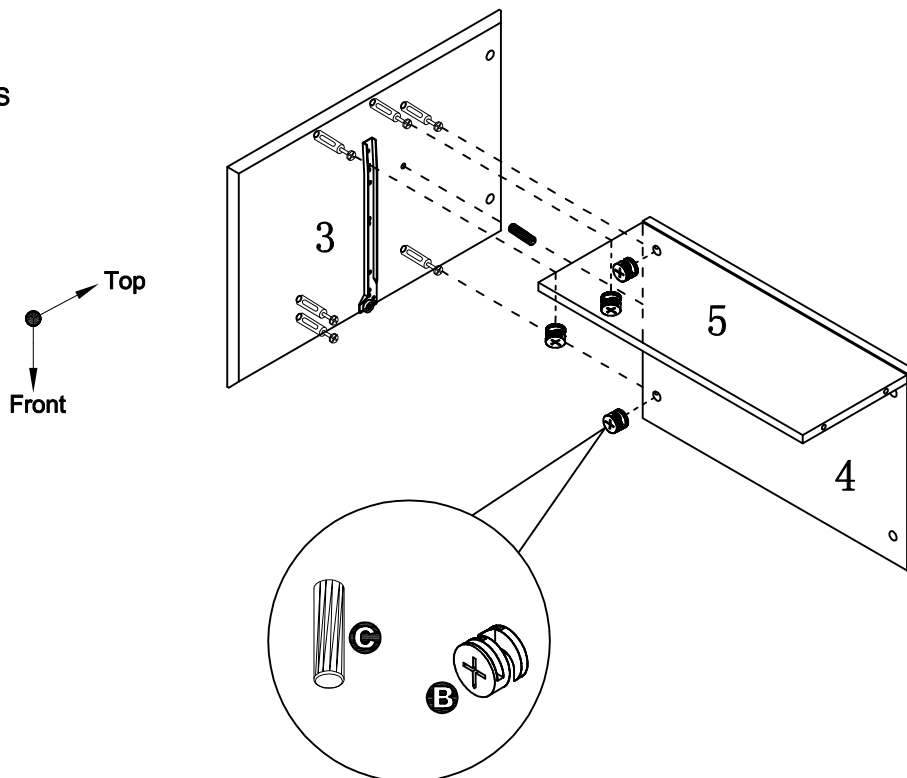

# ASSEMBLY INSTRUCTIONS

## 5

HARDWARE **B** X 2PCS

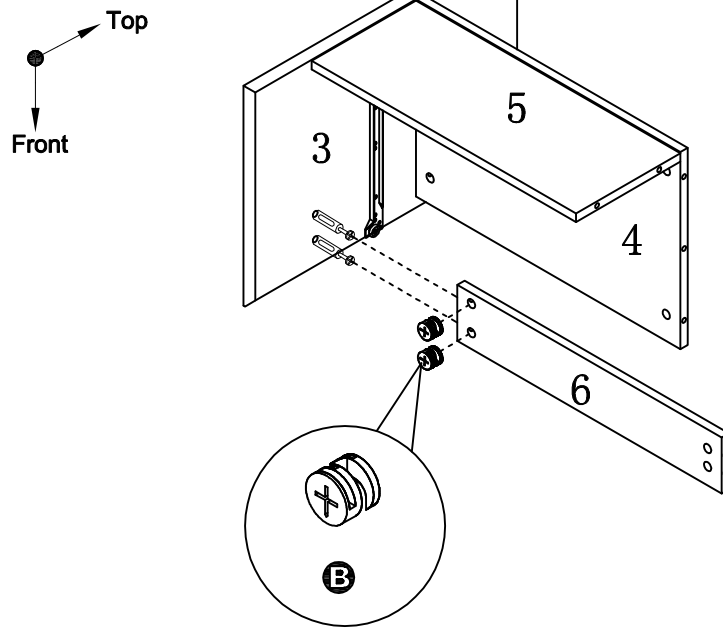

## 6

HARDWARE **A** X 6PCS

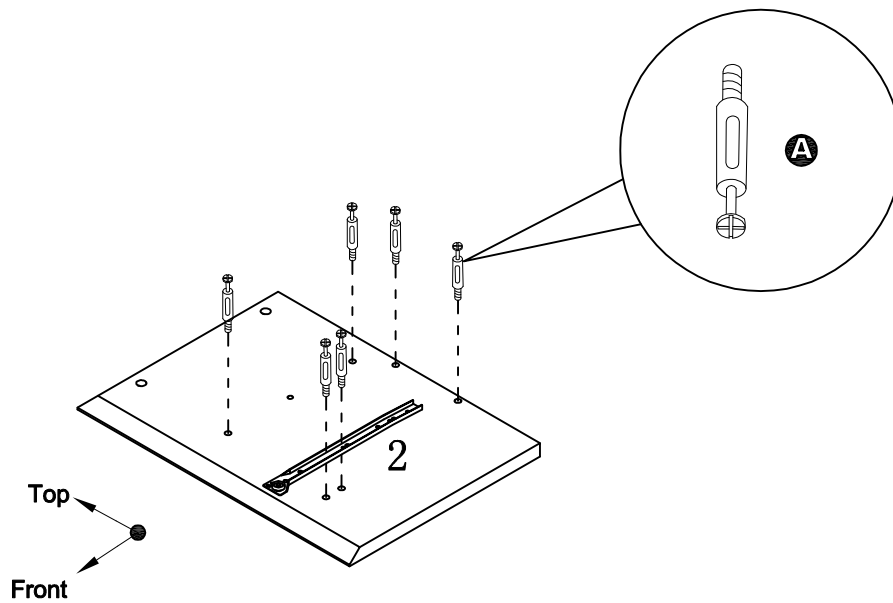

# ASSEMBLY INSTRUCTIONS

## 7

HARDWARE **B** X 6PCS

HARDWARE **C** X 1PC

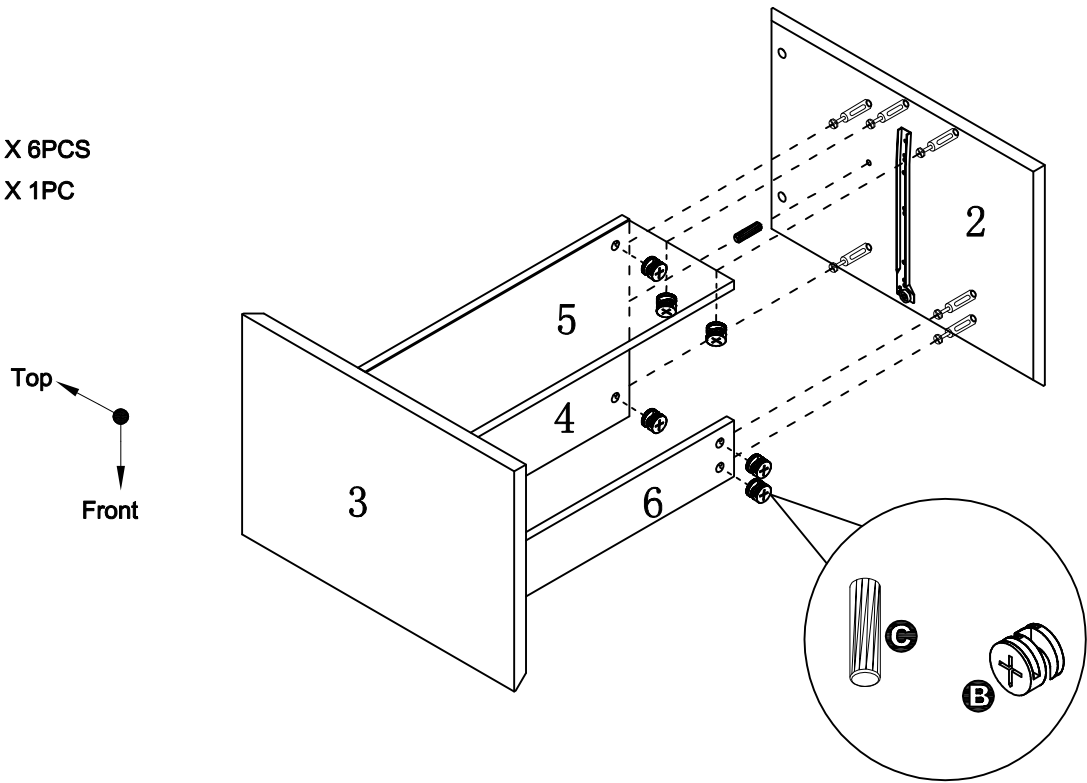

## 8

HARDWARE **B** X 4PCS

HARDWARE **D** X 4PCS

HARDWARE **F** X 4PCS

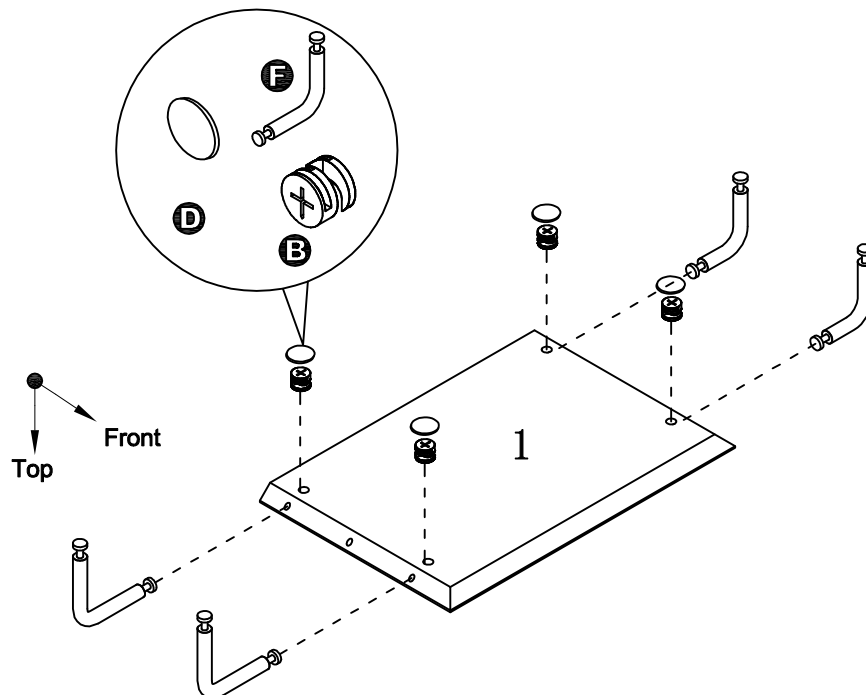

# ASSEMBLY INSTRUCTIONS

## 9

HARDWARE **B** X 4PCS

HARDWARE **D** X 4PCS

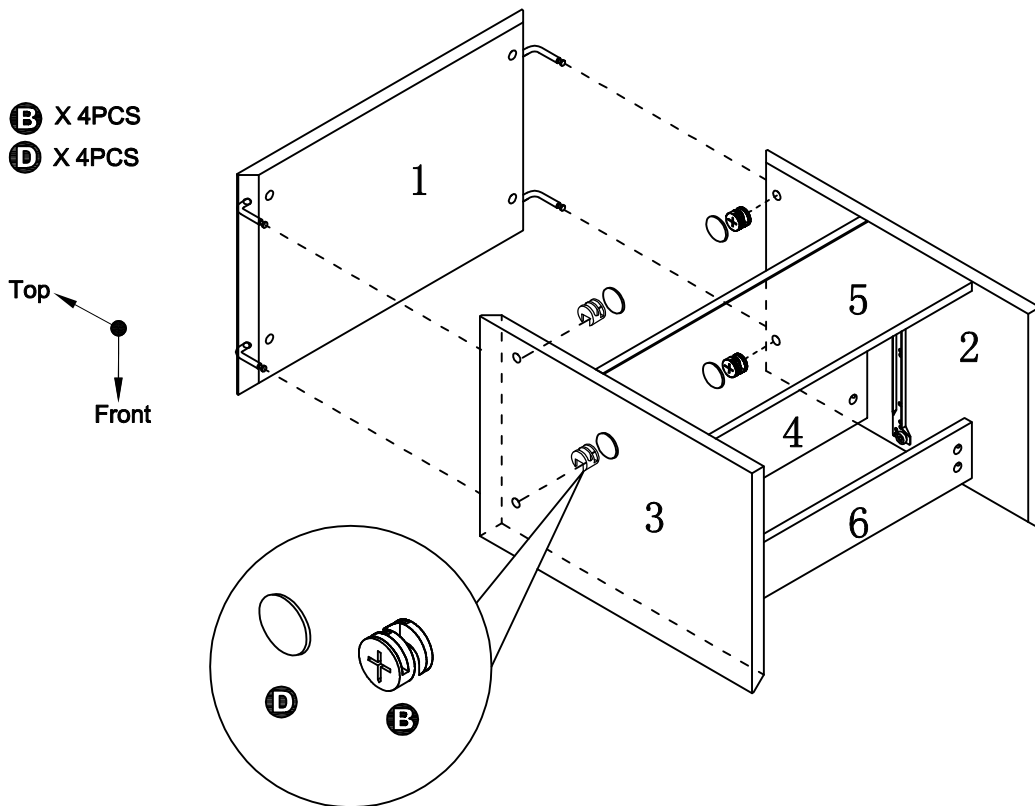

## 10

HARDWARE **H** X 4PCS

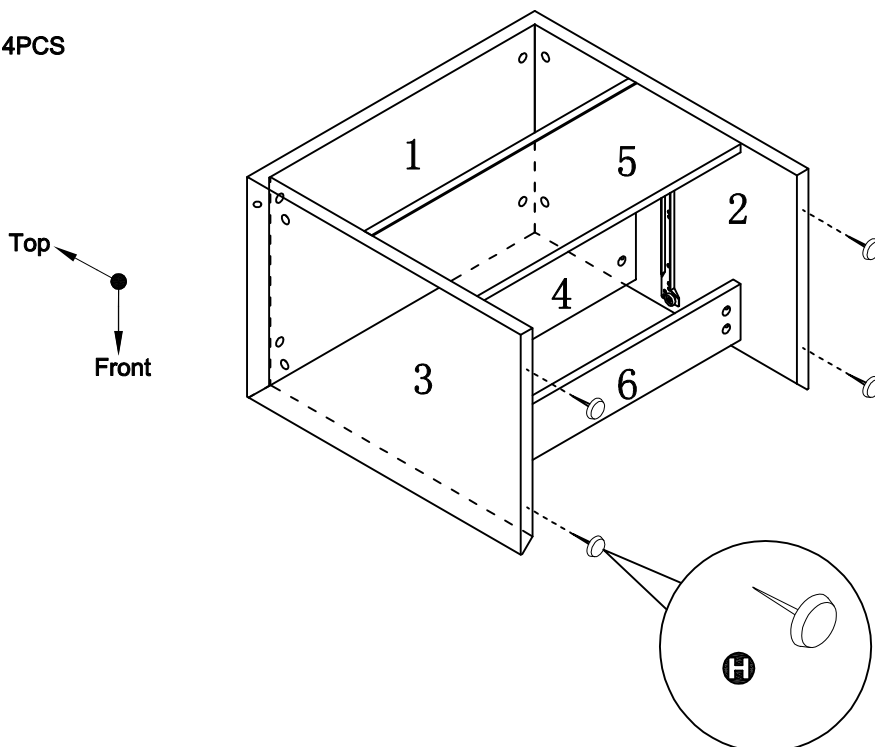

# ASSEMBLY INSTRUCTIONS

## 11

HARDWARE  X 6PCS

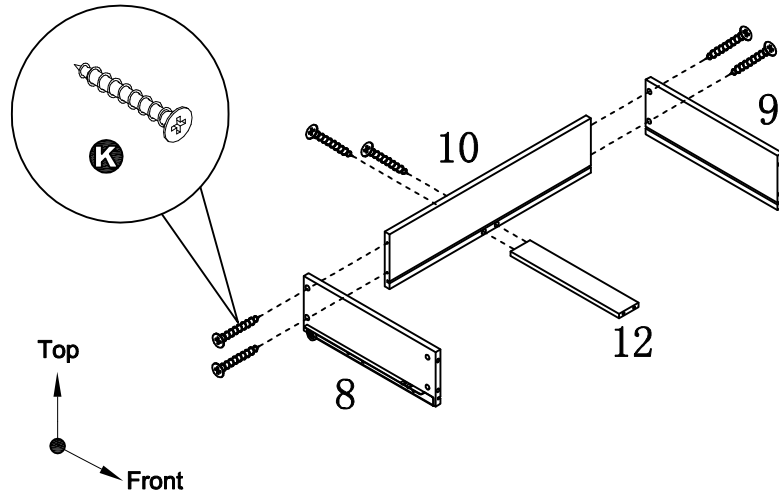

## 12

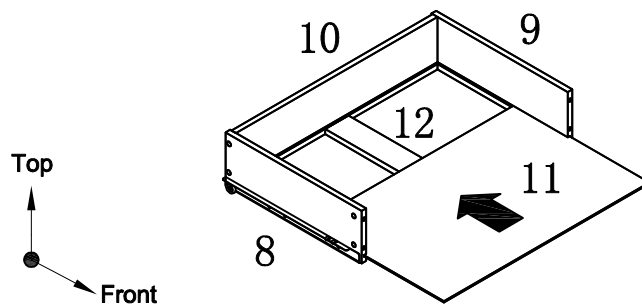

# ASSEMBLY INSTRUCTIONS

## 13

HARDWARE  X 5PCS

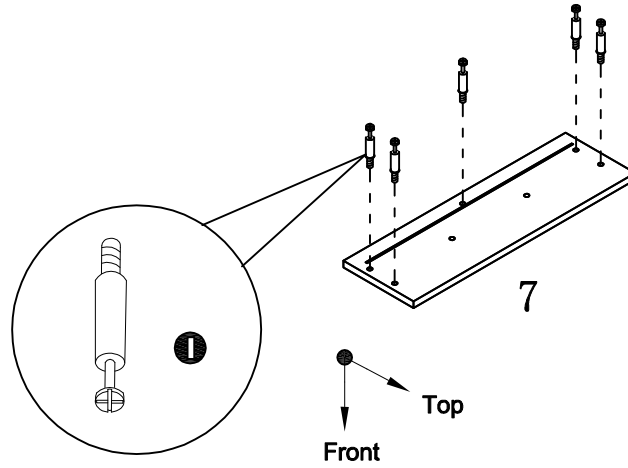

## 14

HARDWARE  X 5PCS

HARDWARE  X 4PCS

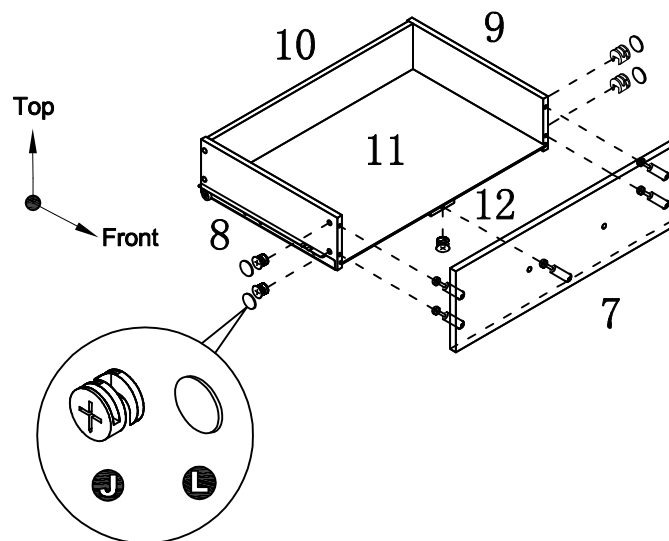

# ASSEMBLY INSTRUCTIONS

## 15

HARDWARE **E** X 1PC  
HARDWARE **G** X 2PCS

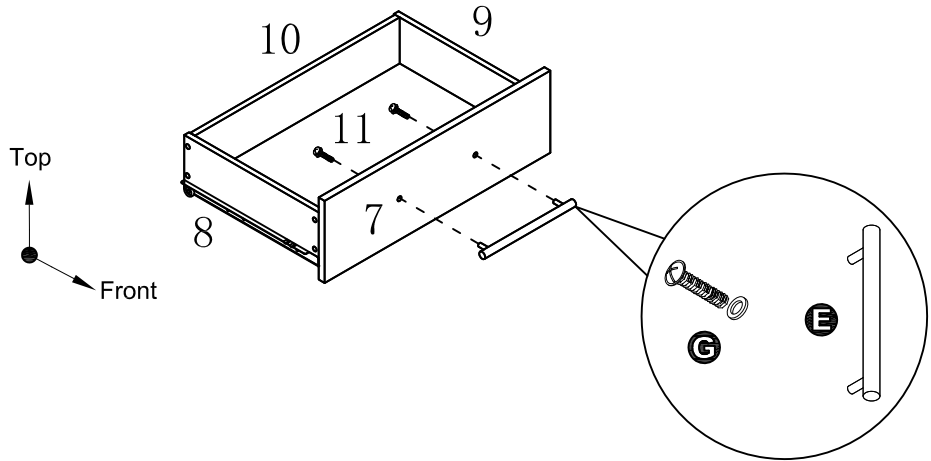

## 16

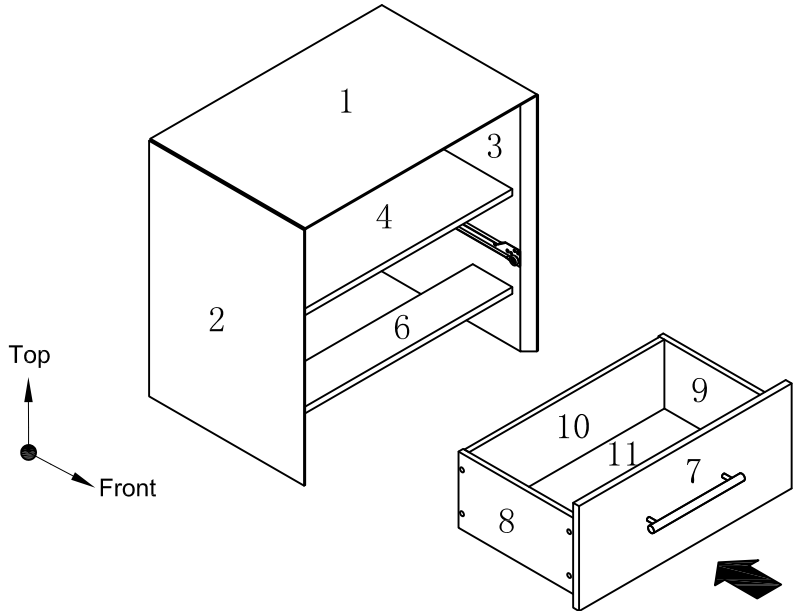

### ASSEMBLY COMPLETED



Please ensure the furniture rests on an even and flat surface. If the product wobbles or feels loose, double-check all bolts and/or screws are properly tightened and secured.

#### ✓ Keep this handy!

Please retain this instruction manual and any order-related information for future reference.

#### ✓ Lift, don't drag!

To avoid damage to product please always LIFT the product when transporting or adjusting the placement.

