

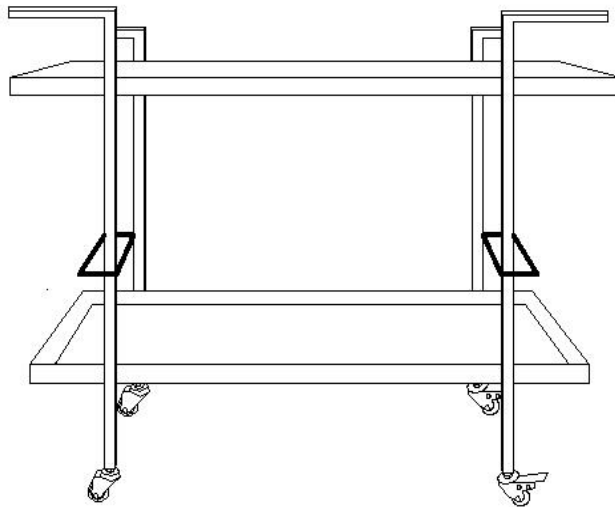

# Assembly Instructions

**Caution : You must read this before you proceed**

## Trolley





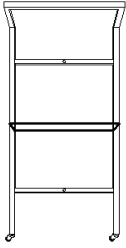
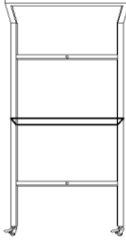

### Parts List

Label	Picture	Description	QTY
A		Top Tray	1
B		Bottom Tray	1

C		Left Side Panel (with Wheels)	1
D		Right Side Panel (with Wheels)	1

## Hardware

Label	Picture	Description	QTY
①		Bolt (M6X30mm)	9
②		Bolt (M6X50mm)	5
③		Washer	13
④		Allen Key	1

## Assembly Preparation

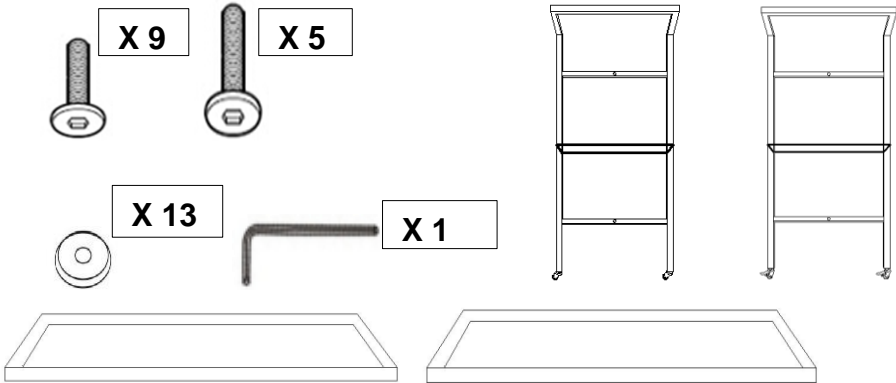
<p>Before Beginning Assembly:</p>	
-----------------------------------	--



- Read instructions, cover to cover-



- Have 2 adults on hand for assembly-



- Do not assemble on flooring or carpet-



- Assemble on a clean non-marring surface (packing foam)-



- Save all packaging until finished-

## Assembly Steps

### Overview

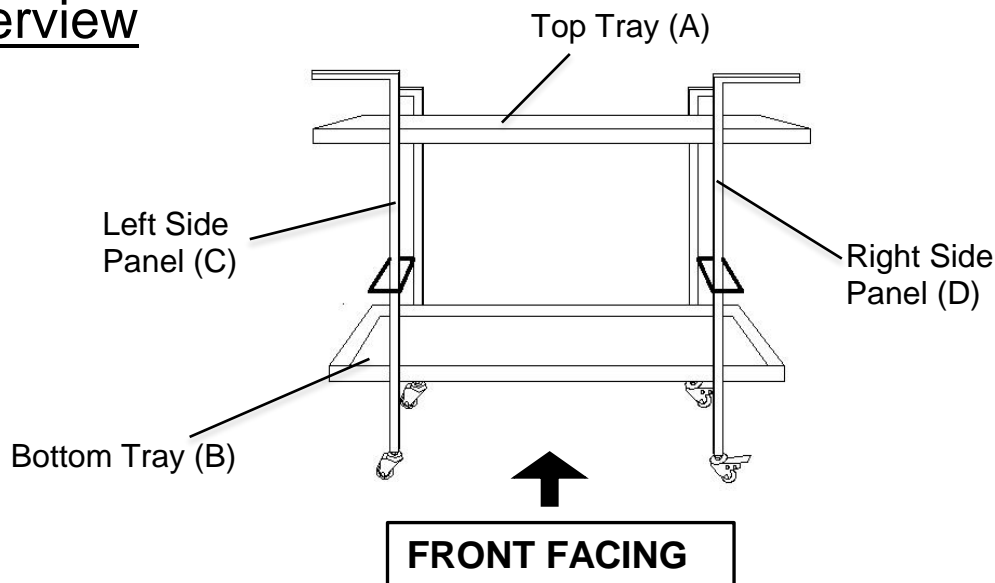

This Trolley has multiple parts and may require up to 30 minutes to assemble. To give you an overview of the Trolley parts, the above picture is to help you put the various parts into perspective. Please read through the instructions below to familiarise yourself with the parts and steps before assembly.

## Step 1

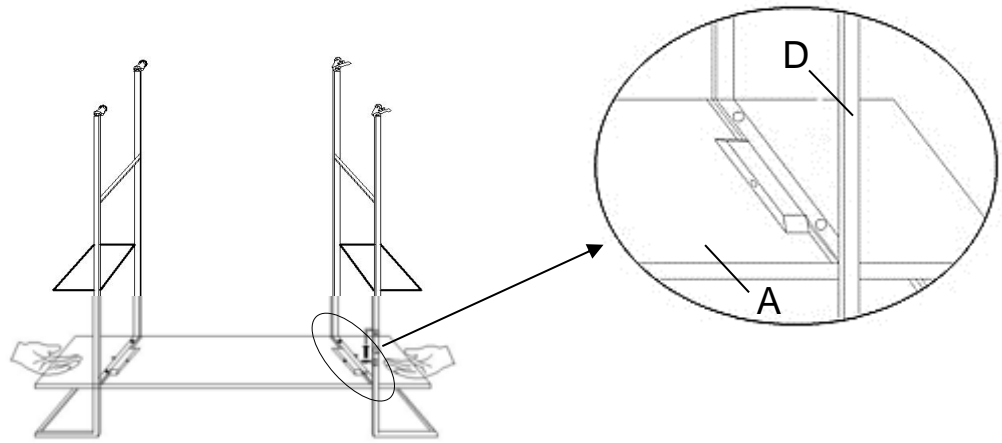

Place the Left Side Panel(C) and Right Side Panel(D) facedown on a clean non-marring surface.

With assistance from an adult partner, align the mounting positions on Top Tray(A) with Left Side Panel(C) and Right Side Panel(D).

## Step 2

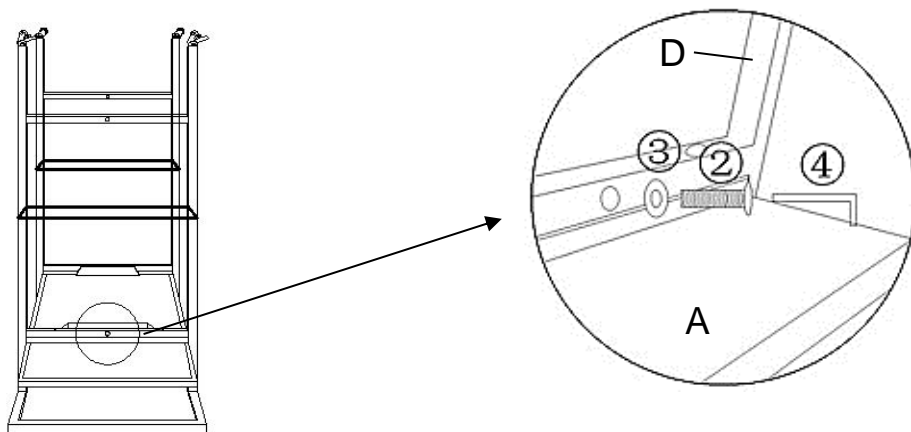

Attach Right Side Panel(D) to the Top Tray(A) through the pipe into the wooden block using Bolt(②) and Washer(③) with Allen Key(④).

Repeat the same process to attach Left Side Panel(C).

**Do not fully tighten the Bolts.**

### Step 3

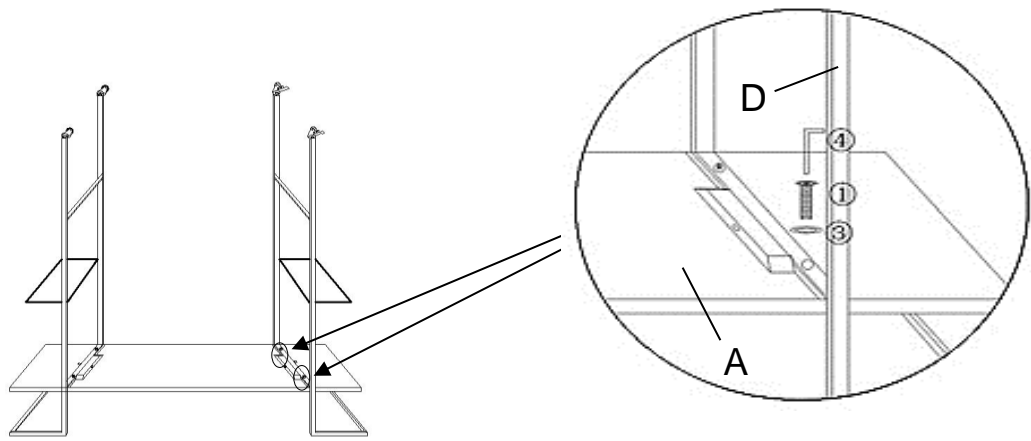

Attach Tray(A) to Right Side Panel(D) using Bolts(①) and Washers(③) with Allen Key(④) as pictured above.

Repeat the same process to attach Left Side Panel(C).

**Do not fully tighten the Bolts.**

### Step 4

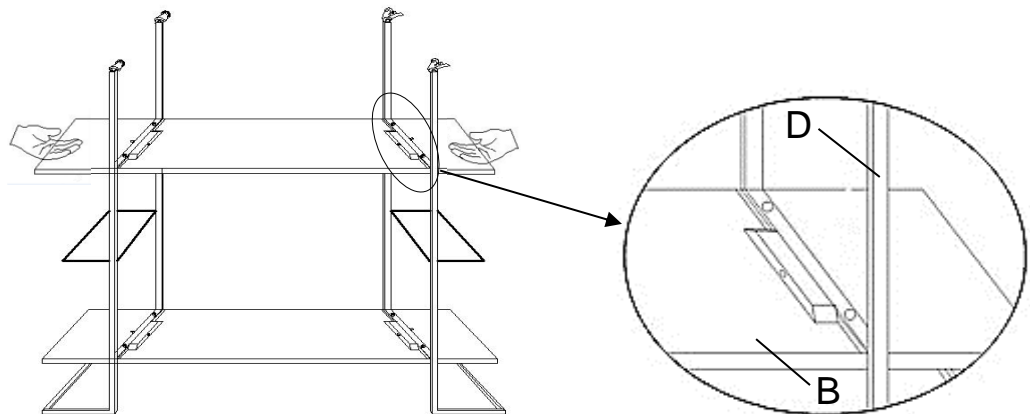

With assistance from your adult partners, place the Bottom Tray(B) facedown and align the mountings positions on Left Side Panel(C) and Right Side Panel(D).

Repeat the same process from **Step 2** and **Step 3** to attach Bottom Tray(B).

**Now fully tighten all Bolts at all joints in a sequential manner.**

## Step 5

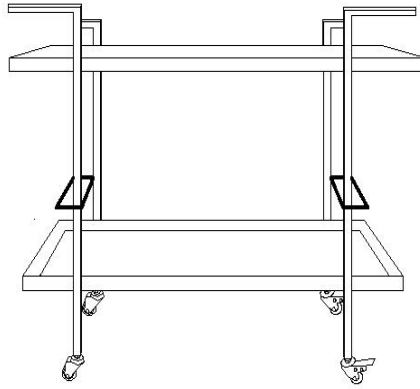











Stand the Trolley up.

Your Trolley is now ready for use.

**This Trolley can only be used on a flat, level surface.**

**Note: The wheels on the Right Side Panel(D) can be braked by pushing down on the Levers.**

## Care & Maintenance

-  ● Do not put hot items directly on furniture surface
  -  ● Do not clean furniture with harsh cleansers or polish.
  -  ● Do not place furniture under direct sunlight.
  -  ● Do not place furniture near heating or cooling vents.
  -  ● Do not write on furniture without a padded barrier to protect the surface.
  -  ● Do not place furniture outside . For indoor use only .
  -  ● Not for commercial use. For residential use only .
  -  ● Stains may be removed with mild soap solution and damp cloth.
  -  ● Children should not climb or jump on the furniture.
- 
-  ● Dust and pick-up spills using a clean, non-colored, lint-free cloth .

### What is Proposition 65?

Proposition 65 is a California law that requires warning labels on products that may contain one of more than 800-plus chemicals or ingredients that the California Office of Environmental Health Hazard Assessment (OEHHA) has deemed to cause cancer or other reproductive toxicity. Chemicals and elements on this list include wood dust, brass, and other everyday substances, which can be found in very common household items, such as: lamps, tableware, jewelry, crystal glasses, electric cords, beauty products, automobiles, and furniture.

### Why Did I Find a Proposition 65 Warning on My Home Goods Product?

We include Proposition 65 warnings on all of our products because there is always a chance that one of the 800-plus common chemicals and ingredients listed under this law could potentially be on our furniture or packing materials. We risk large fines under this law, if we don't include this warning.

### Should I worry?

We realize you may be worried finding this warning on our products, but we want to reassure you that the hazardous exposure limits for any of these chemicals have never been found on furniture products that we've shipped to our customers. Additionally, this warning label is very common and can be found on almost every piece of furniture sold in the state of California.

### Just How Common Are Proposition 65 Warnings?

Proposition 65 warnings have become so common in California that it is hard to take a trip to a local bank, grocery store, or restaurant without finding at least one warning. In fact, even the Disney Land Resort has a Proposition 65 warning:

