

Let's build the

# Tamlin Wall Light

SKU 15002

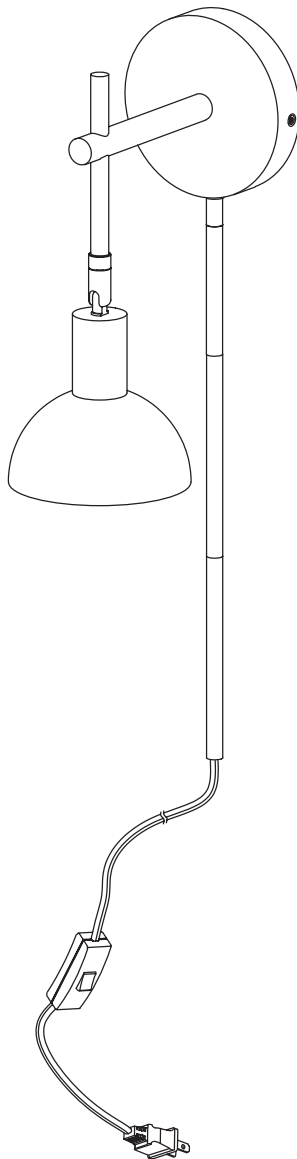

**Scan me!**

Free Lifetime  
Warranty

nathan james

# Ok, let's get rolling

This should be easy, just follow our instructions and you will be back to Netflix in no time.

## Estimated time for assembly



35:00

## What you need

- Your favorite snack or energy bar (Save the bubbly for once your fixture is safely installed!)
- Use the packaging carton as a working surface to prevent product damage during assembly
- Phillips head screwdriver
- Pencil
- Electric Drill
- 1/4" Drill Bit
- Mallet or hammer (for plug-in installation)

Toll-free at 1-866-619-1004  
Help@nathanjames.com  
Nathanjames.com/help

## What's included

Description	Qty
1 Fixture	1
2 6" Stem	1
3 12" Stem	1
4 12" Stem	1
A M3.5*35mm Wood Screws	3
B Wall Anchors	3
C Mounting Plate (Wall)	1
D M4*15mm Fixture Screws	2
E M4*26mm Junction Box Screws	2
F Plastic Plug	1
G Mounting Plate (Electrical Box)	1
H Wire nuts	1
J Wrench	1

Scan me!

Free Lifetime  
Warranty



# Safety first, fun later

Safe use of this product starts with you.

Use this light fixture responsibly with the primary concern for your safety. Follow assembly instructions carefully and inspect product upon receipt and each use.

Nathan James and its parent companies cannot be held legally responsible for any injuries or death resulted from failure to follow instructions or improper use of this product.

Do not modify the structure of this product in any way.

Our products have been tested to meet specific safety measures as they were originally intended to be sold. Any modifications will present the risk of creating significant safety issues which Nathan James will not be responsible for.

## Proper use

- DO NOT** use for commercial purposes
- DO NOT** leave spilled liquid on fixture
- DO NOT** use light fixture if damaged
- DO NOT** make temporary repairs
- DO NOT** use outdoors



### WARNING

Inspect the wire insulation for any cuts, abrasions, or exposed copper that may have occurred during shipping. If there is a defect in the wire, do not attempt installation. Please reach out to our Customer Happiness team at [help@nathanjames.com](mailto:help@nathanjames.com) or 1-866-619-1004



### WARNING: RISK OF ELECTRIC SHOCK

Before starting the installation, disconnect the power by turning off the circuit breaker or by removing the appropriate fuse at the fuse box. Turning the power off at the switch is NOT SUFFICIENT to prevent electrical shock. PLEASE CONSULT A QUALIFIED ELECTRICIAN IF YOU HAVE ANY ELECTRICAL QUESTIONS.

# The goods

1

2

3

4

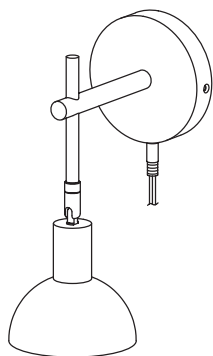

A

B

C

D

E

F

G

H

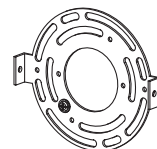
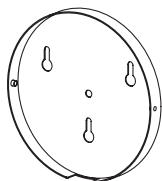
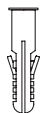

J

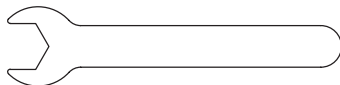

## IMPORTANT

1. Do not tighten bolts / screws completely until all bolts / screws are lined up and inserted into holes.
2. Do not over tighten screws and bolts to avoid stripping.
3. Please use hand tools to assemble this product. Do not use power tools.

## Pre-Installation

- Read all instructions prior to beginning assembly.
- To avoid damaging this product, assemble it on a soft, non-abrasive surface such as carpet or cardboard.
- Keep the receipt and these instructions for proof of purchase.
- Suggested Bulb: G16.5 LED 60 Watt Equivalent | E12 Medium Base | Dimmable
- Max. Wattage: 60W

# Option 1: For Wall-Mounted/ Plug-in Installation

## Step 1

Remove Mounting Plate from the back of the Fixture by unscrewing Part D & separating the Mounting Plate from the Fixture.

Friendly tip:

If you don't need to adjust the length of the stem, skip to Step 7!

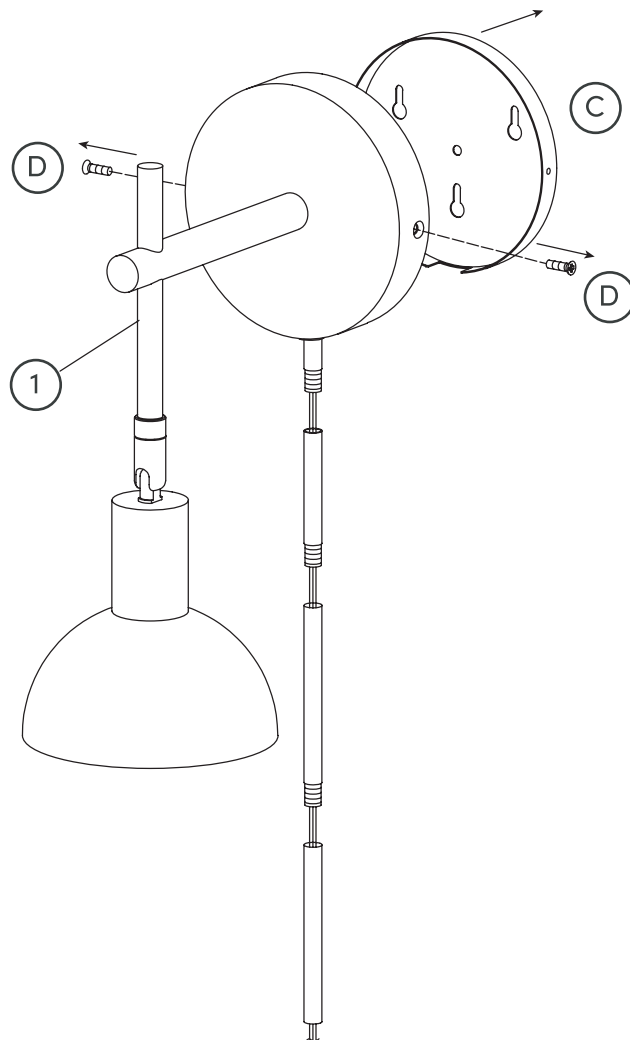

# Step 2

Remove wires that run to the plug from each wire connector component in order to allow the cord to be released out the bottom of the fixture.

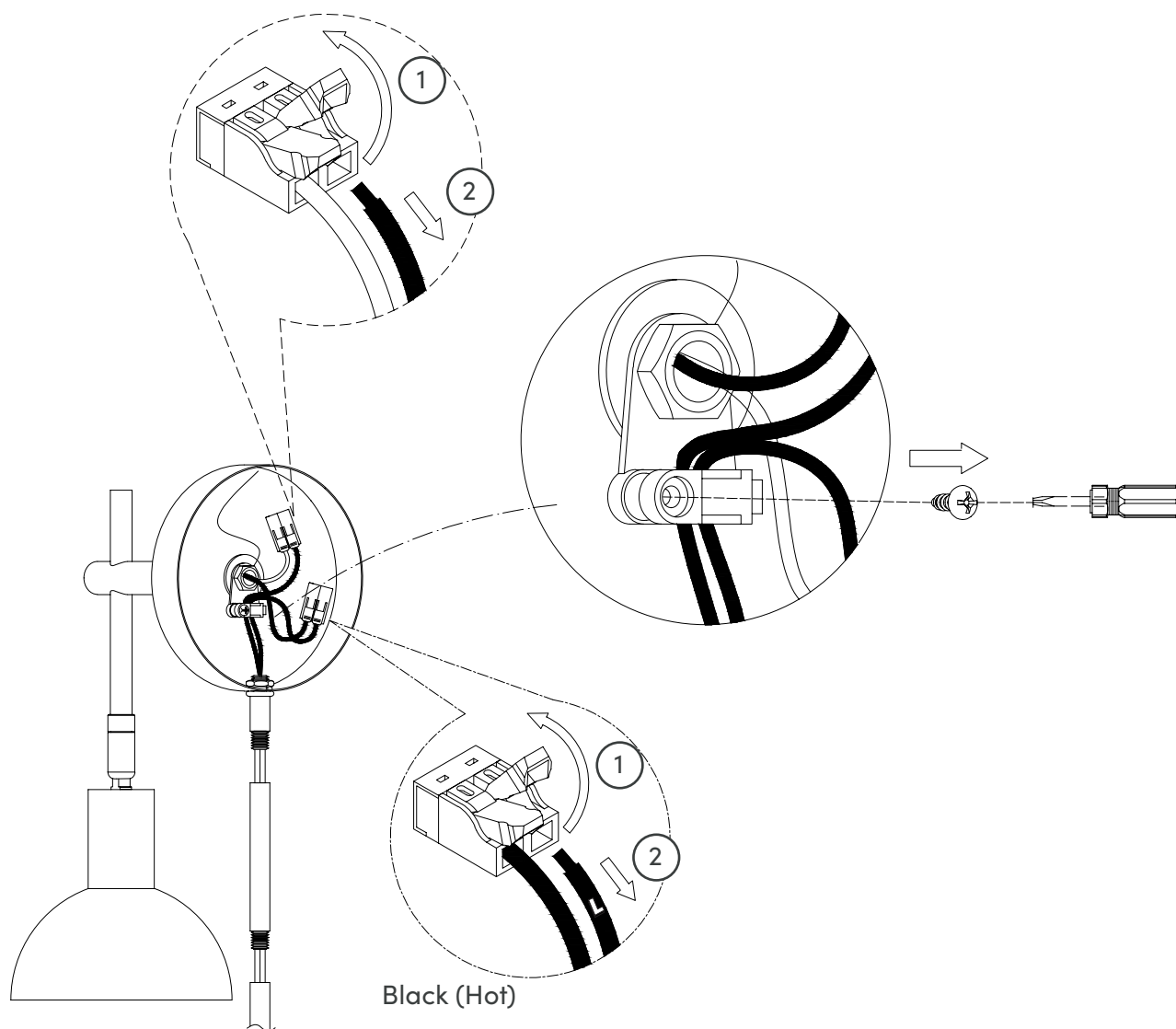

# Step 3

Remove the cord out the bottom of the fixture in order to install the decorative cord stem at its desired length.

You're doing great!

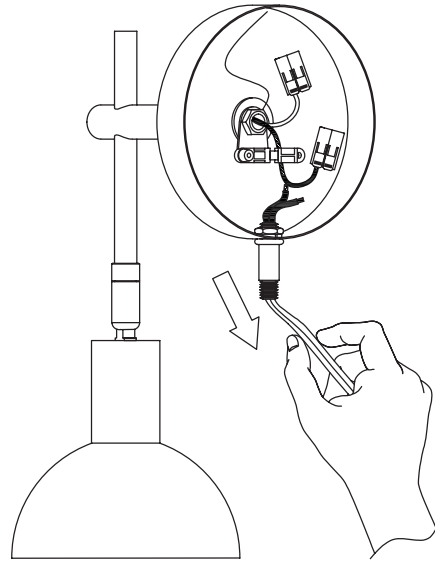

# Step 4

Decide your decorative cord stem desired length.  
(See possible configurations)

Then, pass the cord through each of the selected decorative cord stem components.

12" cord: (4)

18" cord: (2) (4)

24" cord: (3) (4)

30" cord: (2) (3) (4)

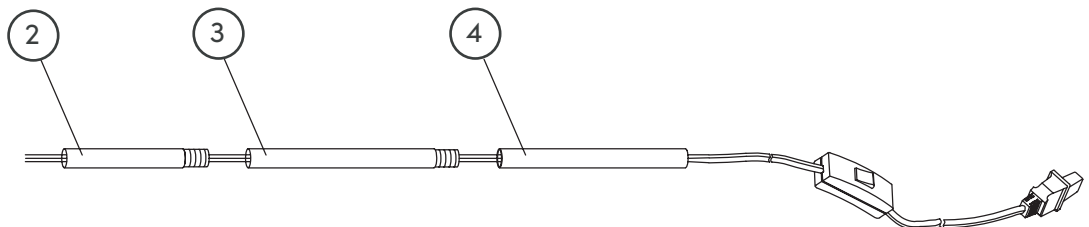
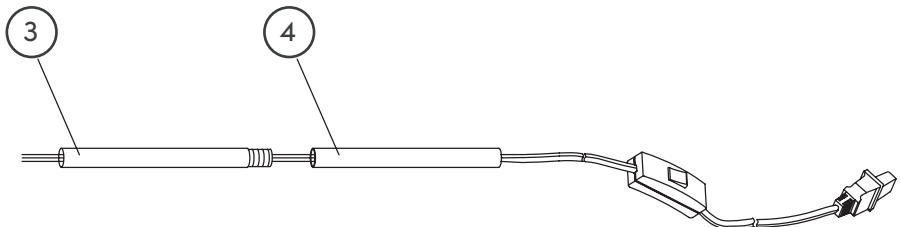
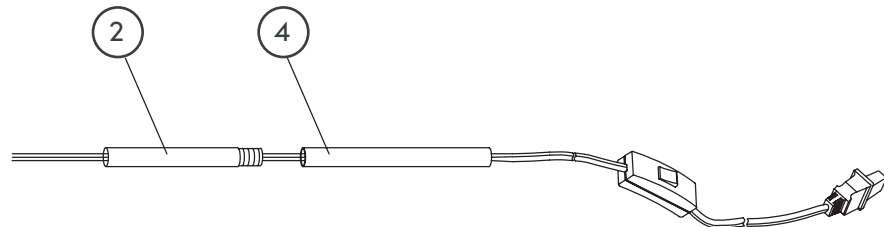
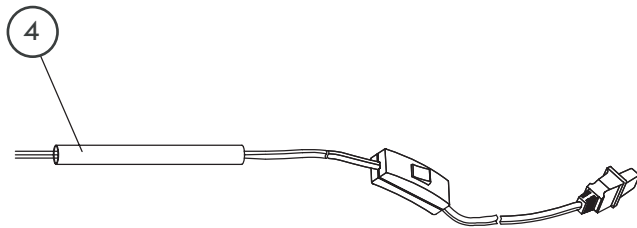
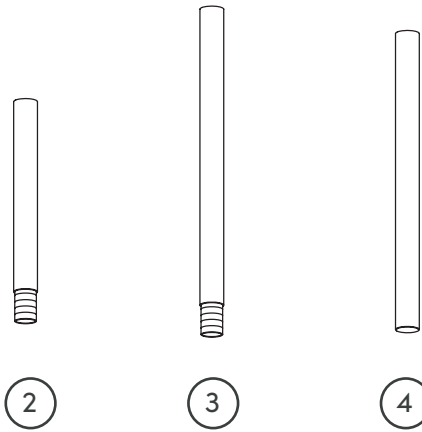

# Step 5

Thread the cord back into the Fixture (1).

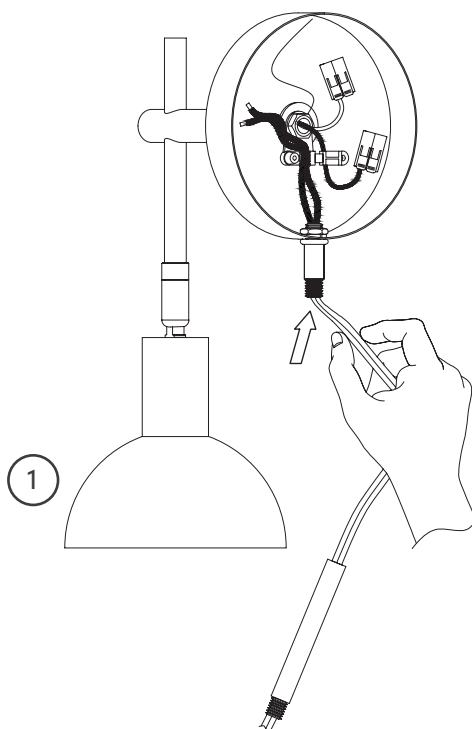

# Step 6

Using the pre-attached wire connectors in the Fixture (1), insert the White (Neutral) wire into the connector with the White wire. Insert the Black (Hot) wire into the connector with the Black wire.

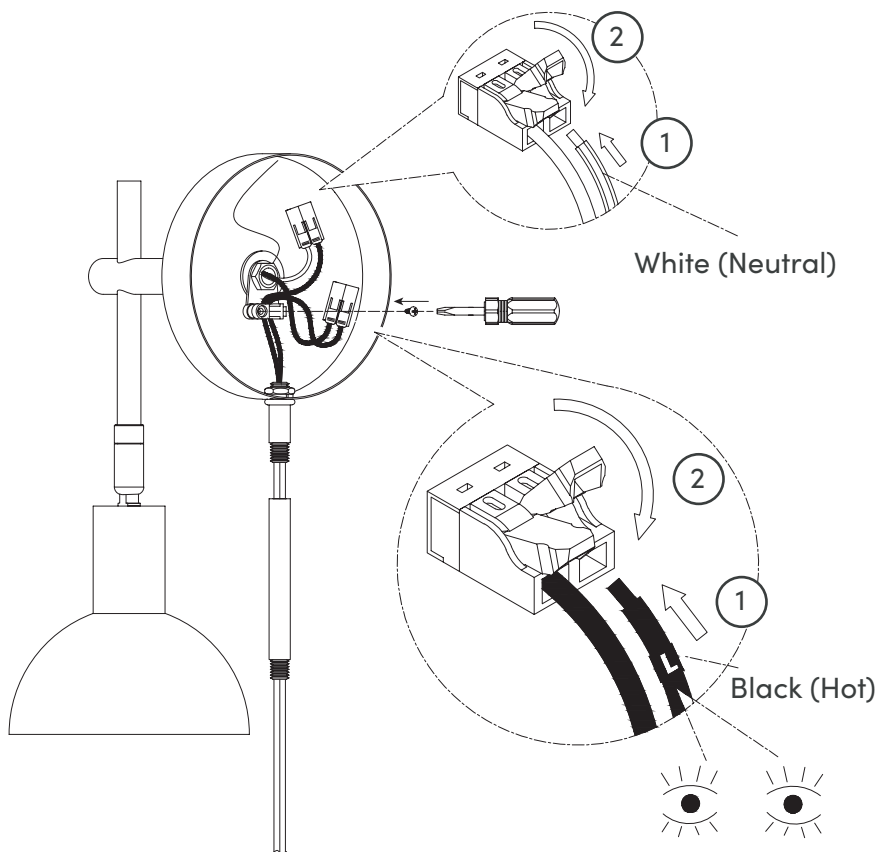

Note: Be sure that you are only making the connections to a 120V 60Hz AC circuit. If you do not have a pre-existing electrical box, we strongly advise using a certified electrician.

# Step 7

Thread the chosen decorative cord stem components (from Step 4) together before finally attaching them to the bottom of the Fixture (1).

Good news: You're halfway done with putting together your wall light!

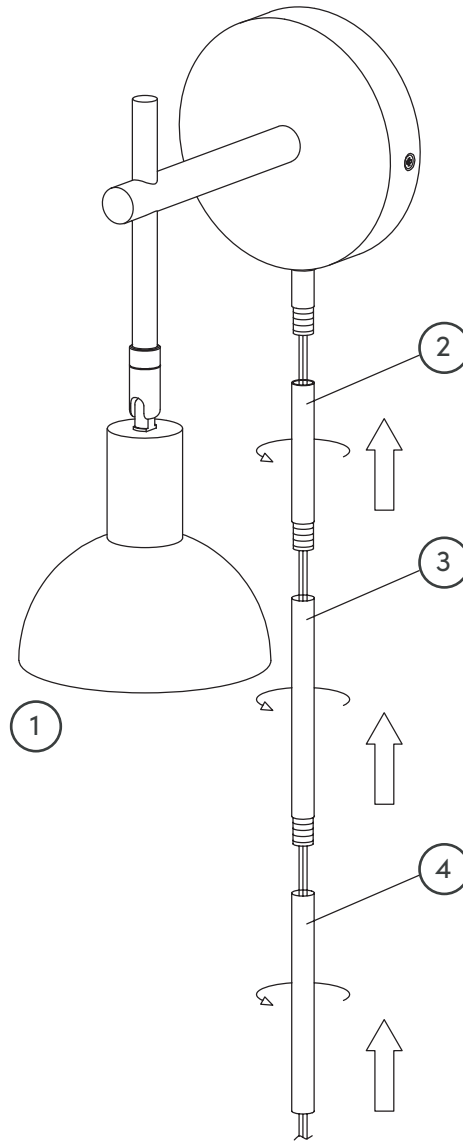

# Step 8

Place Mounting Plate (Wall) (C) in the desired location & height. Use the holes as a guide to mark where you will drill the holes for the wall anchors.

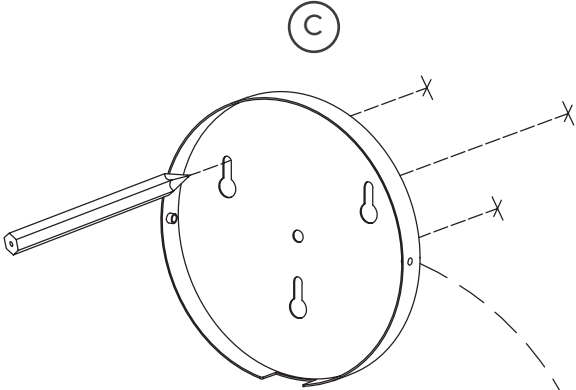

Double check to make sure that everything is level!

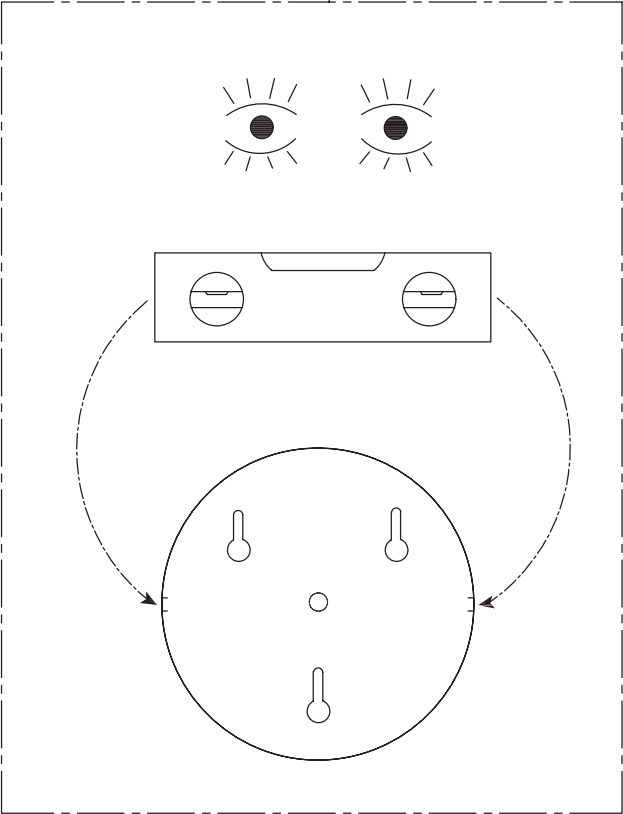

# Step 9

Using a 1/4" (or 6mm) Drill Bit, drill your holes for the wall anchors to be placed in.

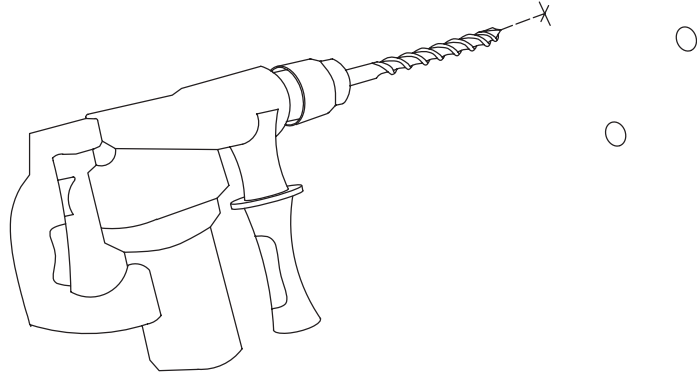

# Step 10

Insert the Wall Anchors (B) into the drilled holes.

If you encounter some resistance, feel free to use something to slightly tap them into place.

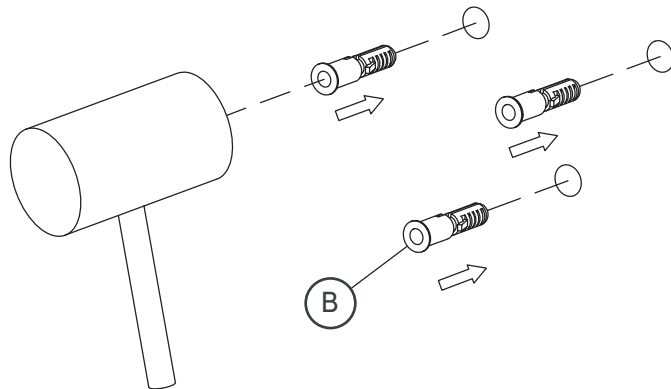

# Step 11

Mount the Mounting Plate (Wall) (C) to the wall by screwing the wood screws (A) into the wall anchors.

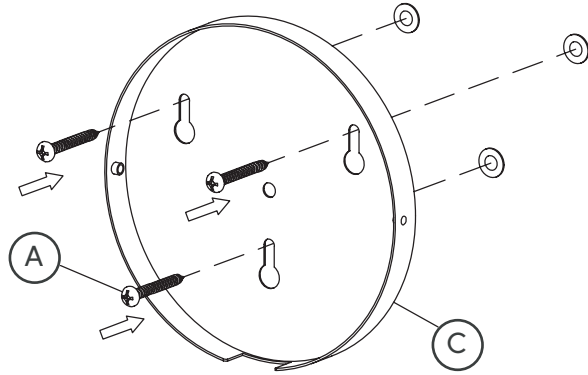

# Step 12

Secure the Fixture (1) to the Mounting Plate (C).

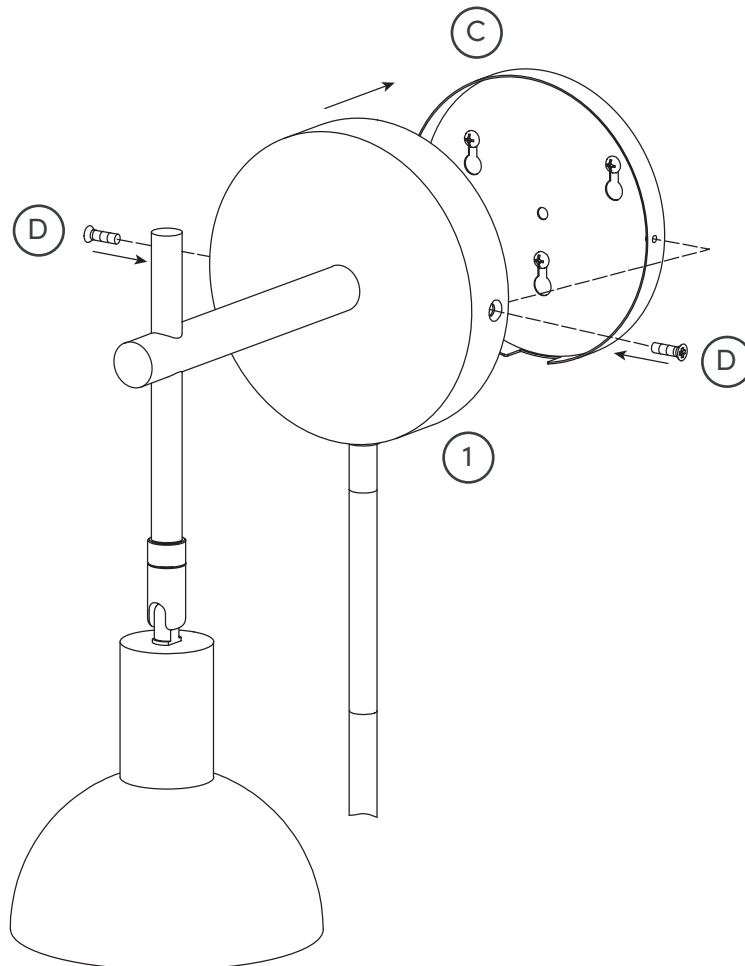

# Step 13

Secure one bulb (we suggest a G16.5 LED 60 Watt Equivalent) into the fixture and hurray! Assembly is complete!

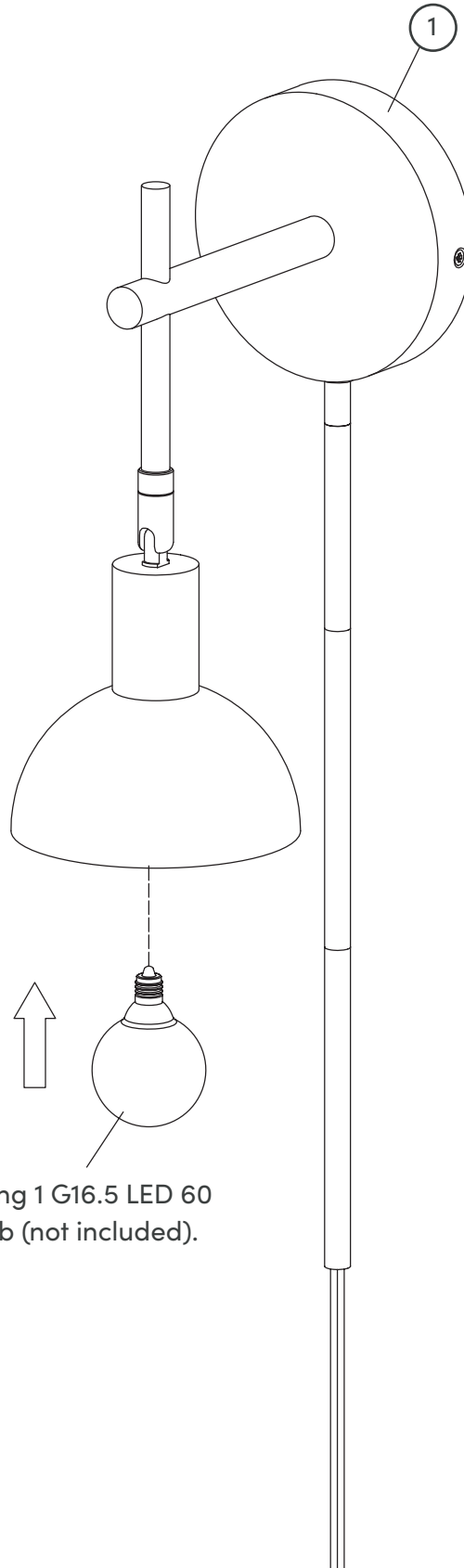

We recommend using 1 G16.5 LED 60 Watt Equivalent bulb (not included).  
120V 60Hz AC only.

# Step 14

Plug it in and let there be light!

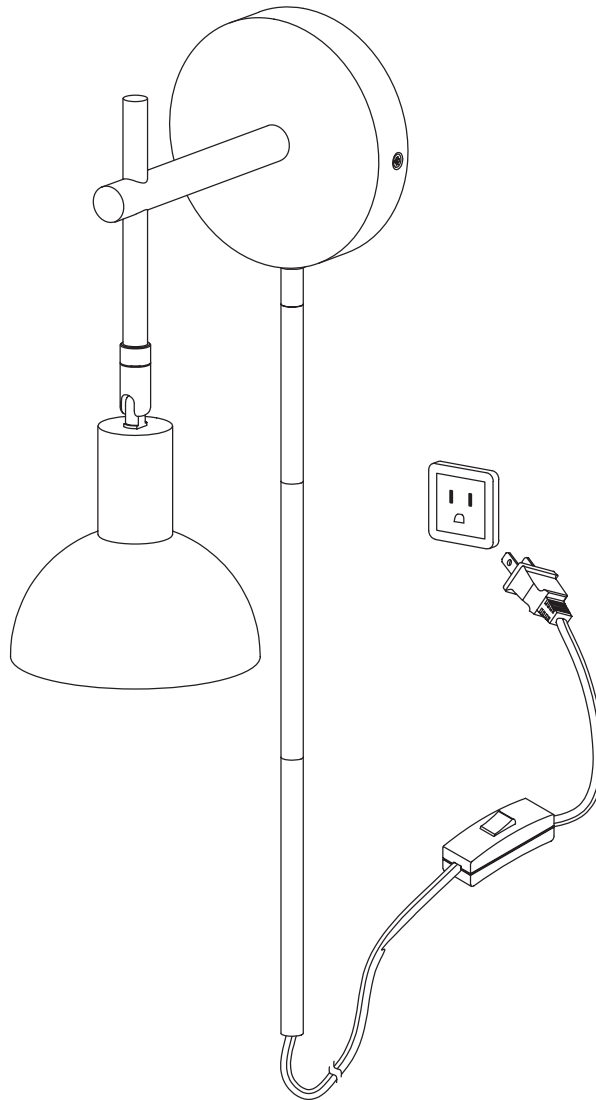

## Troubleshooting

Problem	Possible Causes	Solutions
The bulb will not light.	The bulb is burned out.	Replace the light bulb.
	The power is off.	Ensure the power supply is on.
	The circuit breaker is off.	Ensure the circuit breaker is in the ON position.
The fuse blows or circuit breaker blows when the light is turned on.	There is an exposed wire.	Discontinue use of the light. Contact a qualified electrician or reach out to our Customer Happiness team at <a href="mailto:help@nathanjames.com">help@nathanjames.com</a> or 1-866-619-1004.

# Option 2: For Electrical Box Mounting / Hardwire Installation

## Step 1

Let's get this thing fired up!  
Remove the Mounting Plate (C) from the back of the Fixture by unscrewing the Fixture Screws (D).

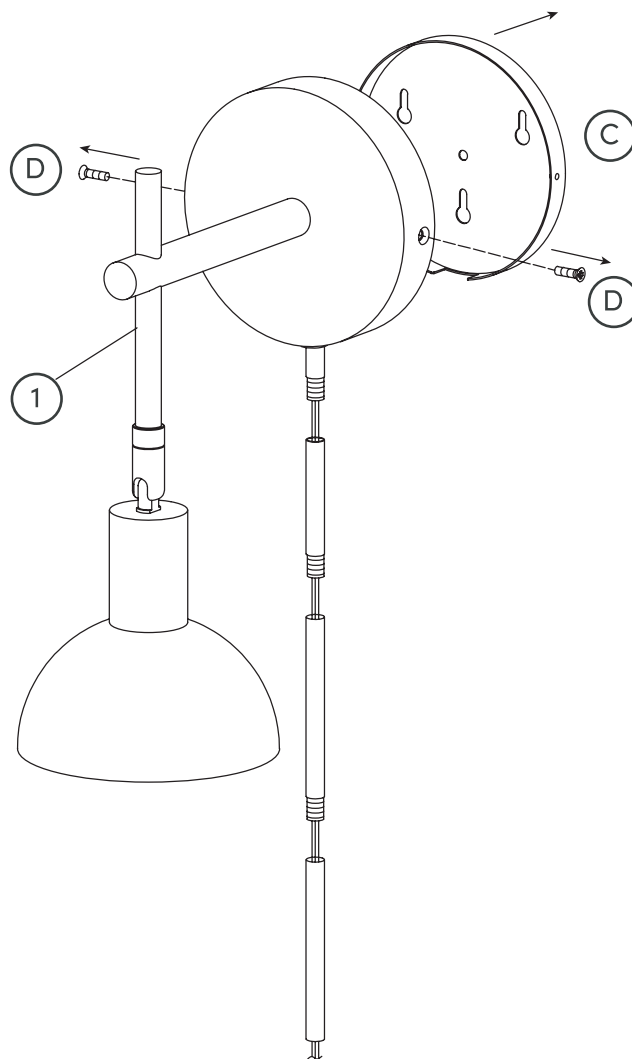

# Step 2

Remove wires that run to the plug from each wire connector component in order to allow the cord to be released out the bottom of the fixture.

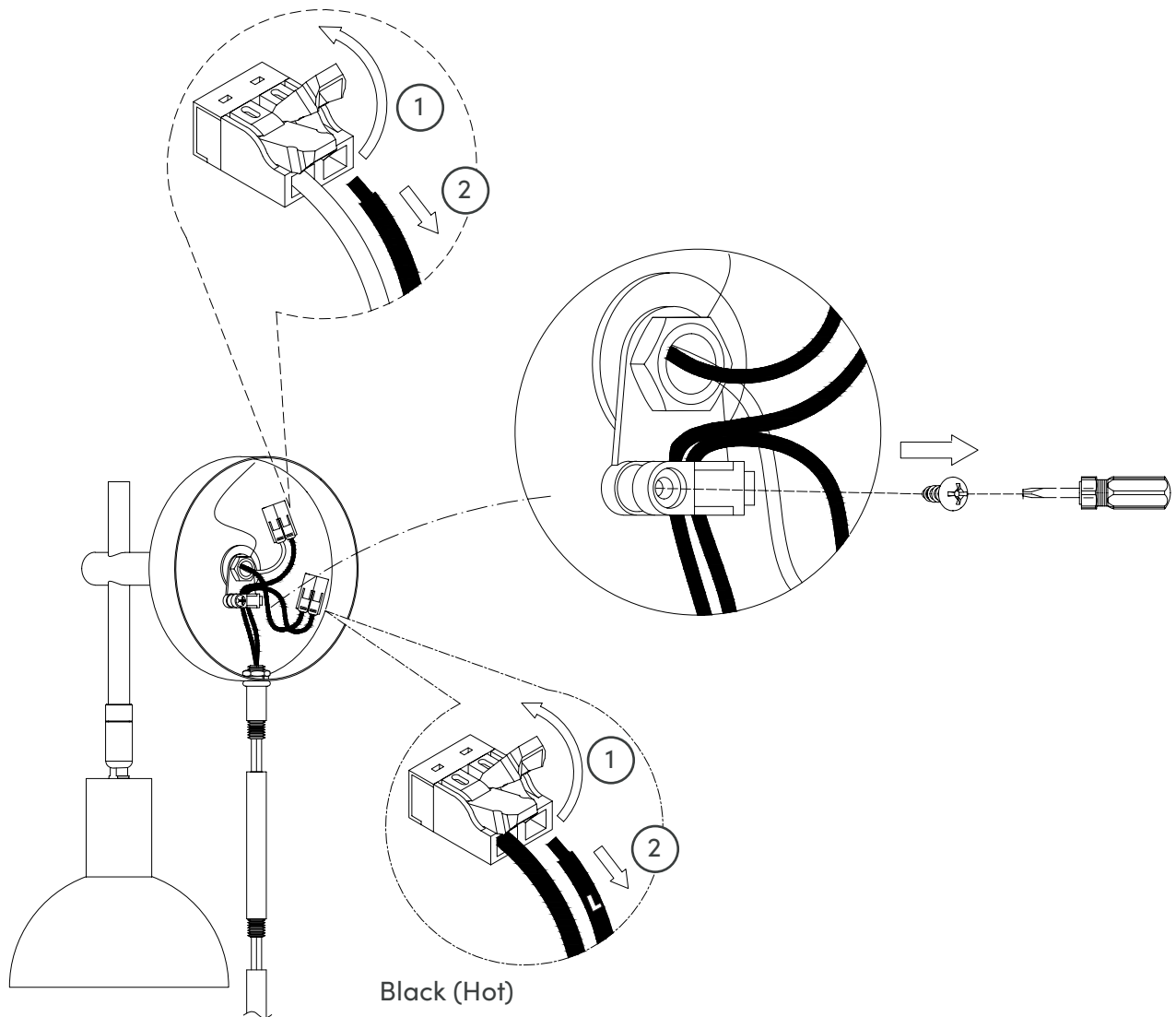

# Step 3

Remove the cord with the plug from the bottom of the fixture.

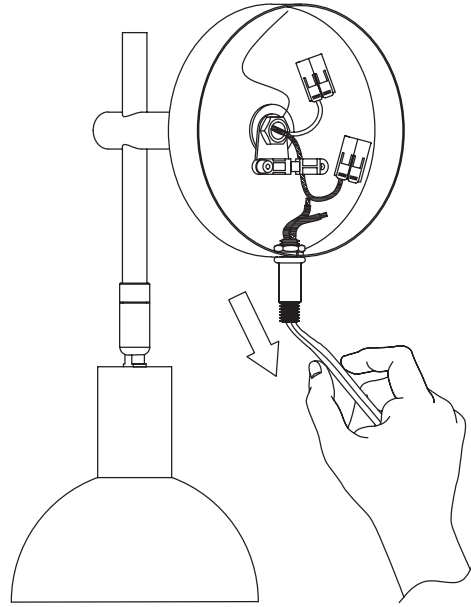

# Step 4

Using the provided wrench, remove the small stem from the bottom of the fixture.

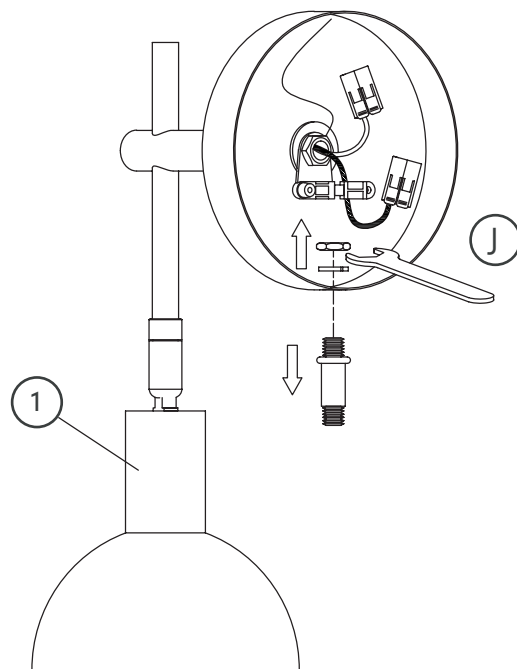

# Step 5

Place the plastic plug inside the hole in the bottom of the fixture that the small stem filled originally.

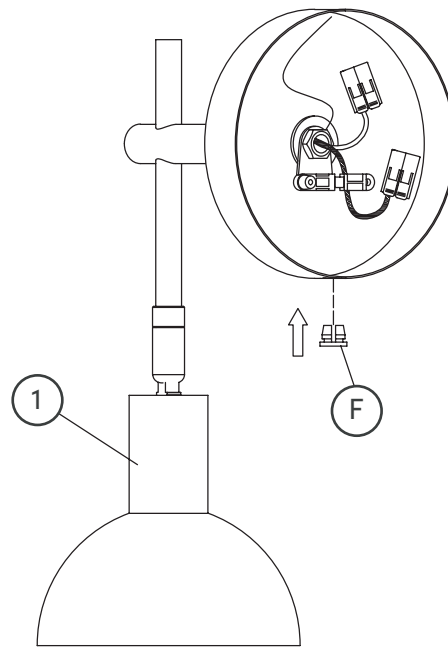

# Step 6

Mount the Mounting Plate (Electrical Box) (G) to the electrical box.

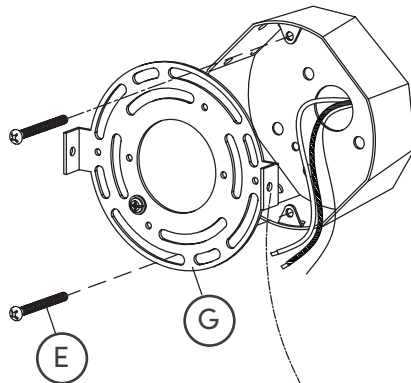

Double check that everything is level!

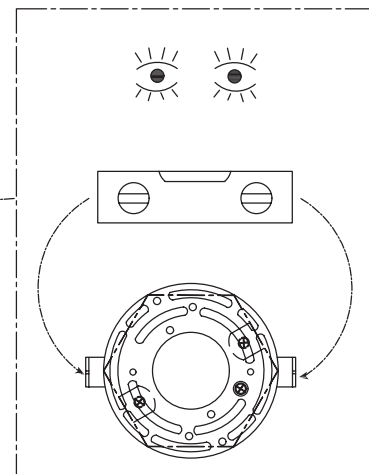

Note: Be sure that you are only making the connections to a 120V 60Hz AC circuit. If you do not have a pre-existing electrical box, we strongly advise using a certified electrician.

# Step 7

Wrap the ground wire from the Fixture around the grounding screw on the Mounting Plate (G) & then secured by tightening the screw.

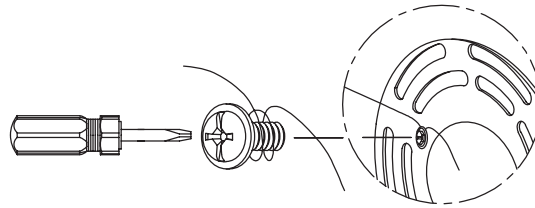

You're doing great! Snack break? We think so.

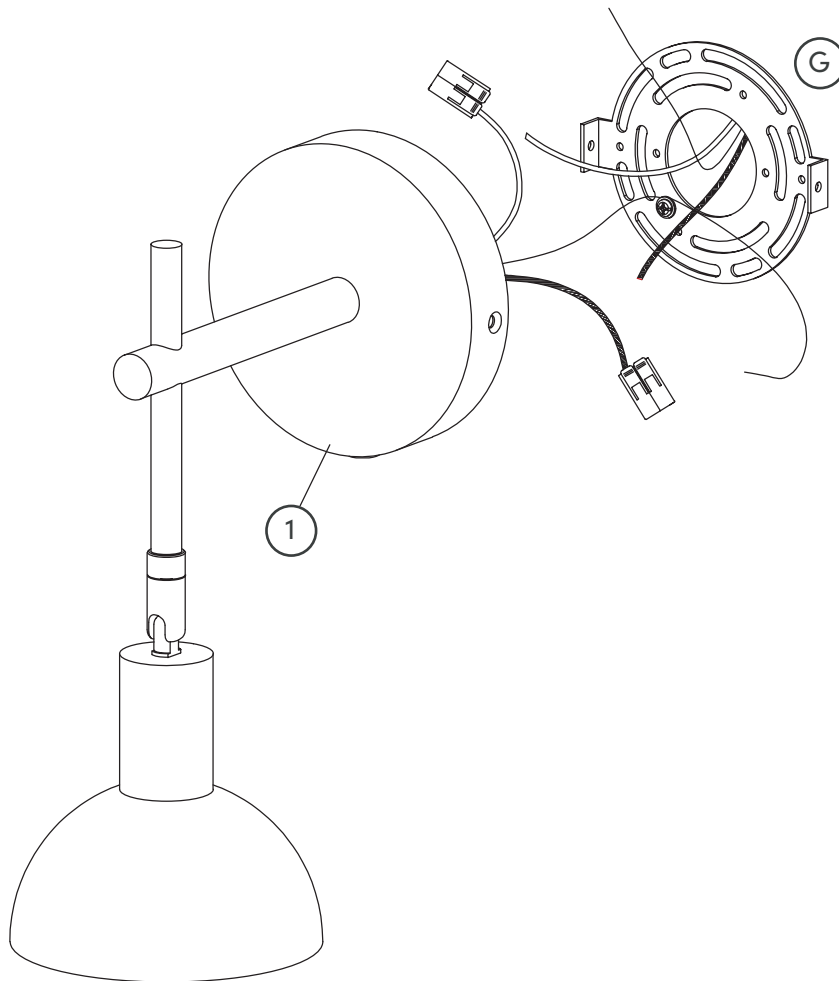

# Step 8

Okay, let's get back to it! Use wire connectors to connect the matching colored wires (White to White, Black to Black). Use the Wire Nuts (H) to connect the ground wire from the Electrical Box to the Ground wire from the Fixture (1).

Once complete, tuck the excess wire into the Electrical Box.

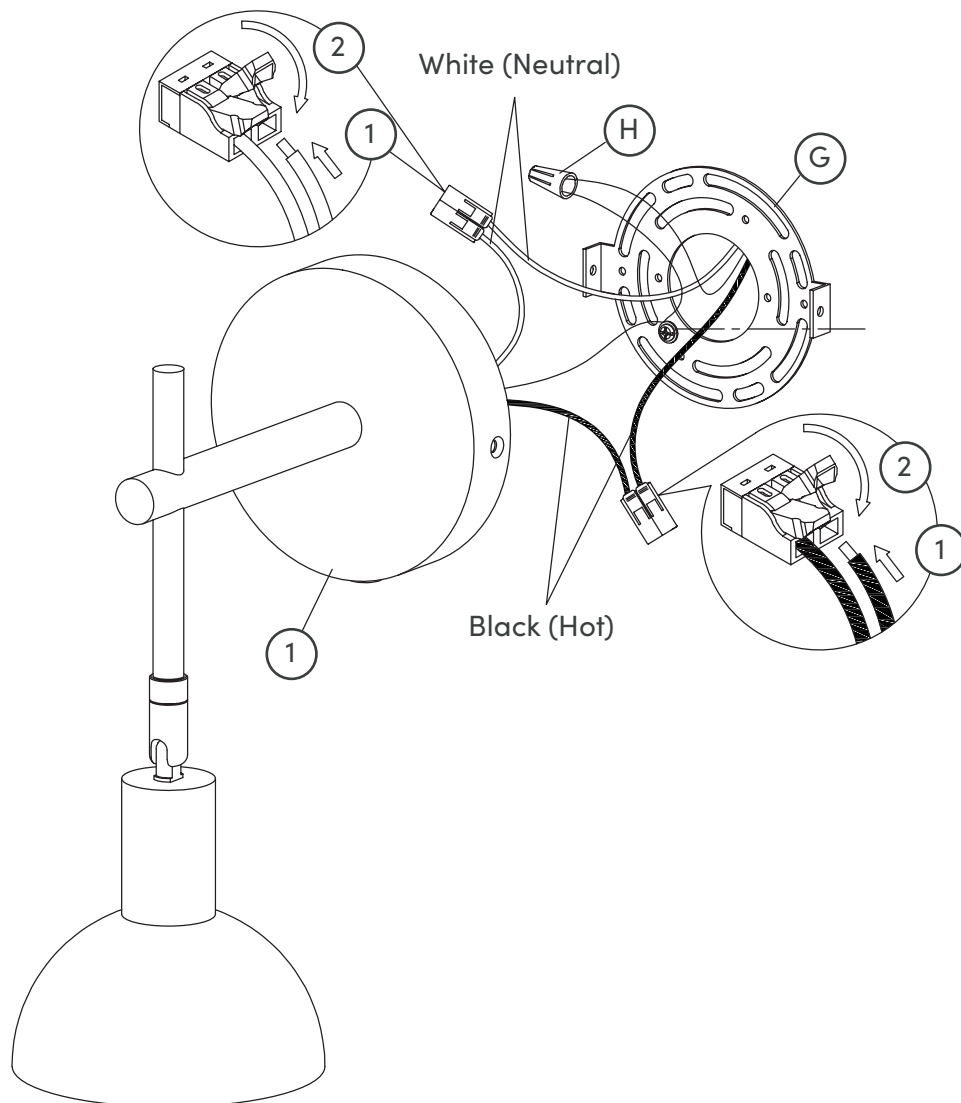

# Step 9

Last step! First secure the Fixture (1) to the Mounting Plate (G). Once fully secure, then install a light bulb (not included) and voila!

Let there be light!

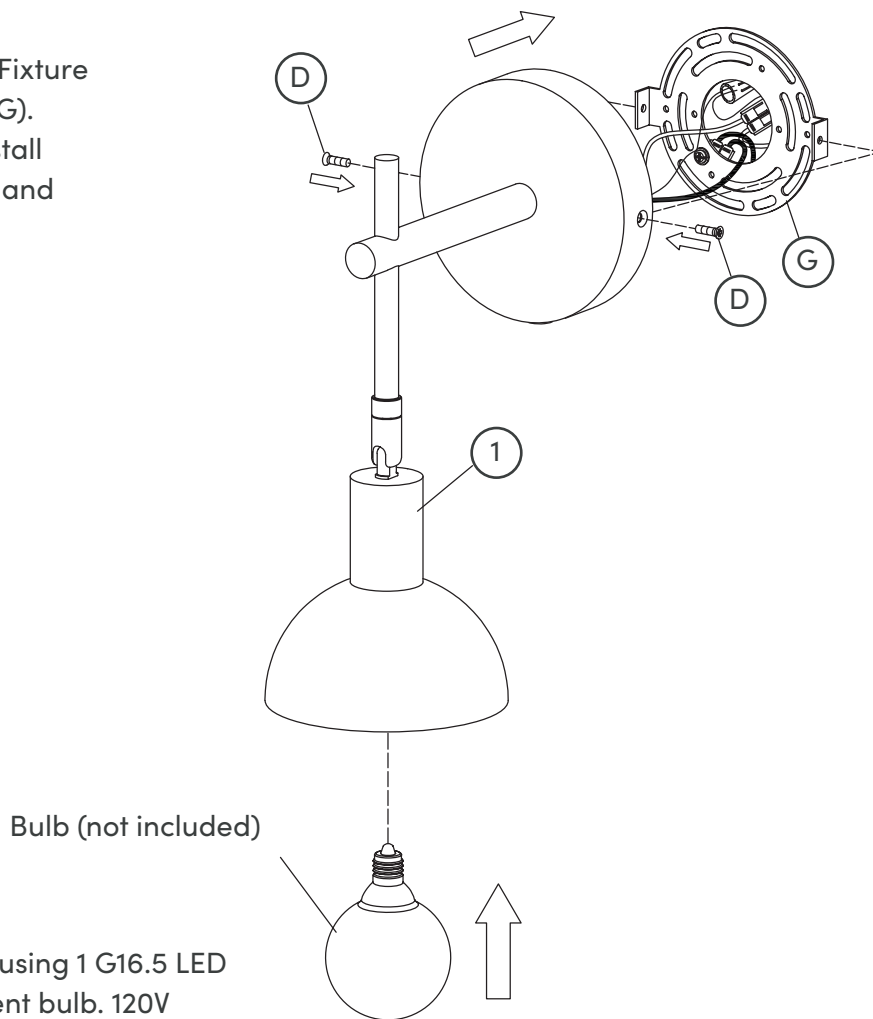

We recommend using 1 G16.5 LED 60 Watt Equivalent bulb. 120V 60Hz AC only.

# Troubleshooting

Problem	Possible Causes	Solutions
The bulb will not light.	The bulb is burned out.	Replace the light bulb.
	The power is off.	Ensure the power supply is on.
	The circuit breaker is off.	Ensure the circuit breaker is in the ON position.
The fuse blows or circuit breaker blows when the light is turned on.	There is an exposed wire.	Discontinue use of the light. Contact a qualified electrician or reach out to our Customer Happiness team at <a href="mailto:help@nathanjames.com">help@nathanjames.com</a> or 1-866-619-1004.

# Questions? Don't worry, we've got the answers

## **What other light bulbs can fit in this light?**

The bulb must not be greater than the max wattage for the fixture. It must match the base size, and the diameter of any area of the bulb should be less than diameter of any area of shade, so that it can fit.

## **Can I use an LED light bulb?**

Yes, so long that the base size matches and the diameter of any area of bulb is less than diameter of any area of shade, so that it can fit.

## **Is this UL/ETL certified?**

Yes, all our products are either UL or ETL.

## **Do I need an electrician to set up the hardwire?**

We recommend using a certified electrician for all hardwiring, although all of our fixtures can be set up without an electrician, as long as you are replacing an existing fixture or have an existing junction box ready for a fixture installation. ENSURE POWER IS OFF WHEN INSTALLING. For all new constructions, please use a certified electrician.

## **Can I retrofit this hard-wired to a plug-in or vice-versa?**

Yes, a plug-in fixture can be turned into a hardwire fixture and a hardwire fixture can become a plug-in fixture. For many products we will provide all the necessary hardware to make these changes, if not, you will need to purchase the necessary hardware.

## **Is this light compatible outside North America?**

Our lighting is only warranted in Canada and the United States.

## **What do I do if the product is not working?**

Try a different light bulb and confirm proper installation.

## **Can these lights work on a dimmer?**

Dimmability is related to the light bulb and the wall switch, not the light fixture. All our hardwire fixtures are compatible with dimmable light bulbs. We recommend using a dimmer switch, as it extends the life of the bulb and allows for energy saving and great ambiance. If using a LED bulb, please ensure both your LED bulb and dimmer switch are compatible.

## **Can I use the fixture outdoors?**

No, this product was designed to be used indoors only in dry locations.

# No heartburn, when we handle the return

Give us a call **1-866-619-1004** or shoot us a message at **help@nathanjames.com** we will issue you a free replacement with **zero hassle**.

## Our way



Give us a call

---



Replacement

---



You

## Their way



Re-package item

---



Schedule pick up

---



Track package

---



Replacement

---



You

We really don't want you to go through the hassle of re-packaging your item and sending it back, because let's be honest...nobody has time for that.

# We are only in business if you're happy

For starters, thanks for being you.

☎ Toll-free at 1-866-619-1004

✉ Help@nathanjames.com

🌐 NathanJames.com/help

We do our best to ensure your product arrives without any problems, but occasionally mistakes happen—as humans we are imperfect beings. In the event that a part is damaged or missing, we will be more than happy to provide you with replacement part(s) for free.

## Warranty

This product comes with a lifetime warranty from the date of purchase. Please use your phone to scan the QR code to register your product or visit <https://goo.gl/i9dk3q>

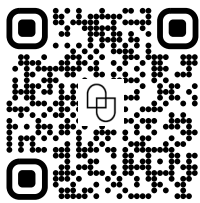

### Did we do alright? Please spread the love!

If you are happy with your product, tell your friends and family about us or even better leave us a review online. Spreading the word gives us the opportunity to make more people happy and keep our prices low for your next purchase.

*Brooklyn Burden*

Founder, Nathan James