

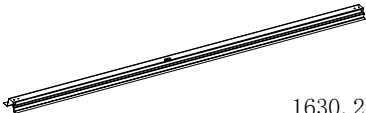











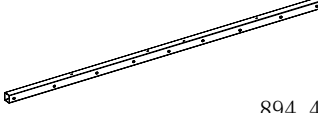
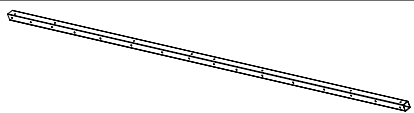
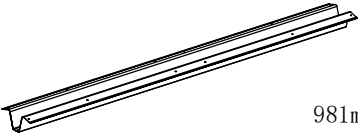



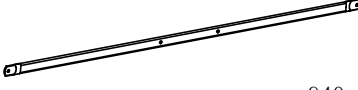
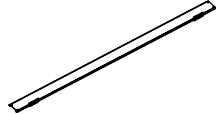

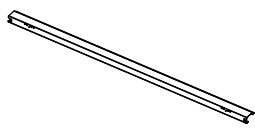
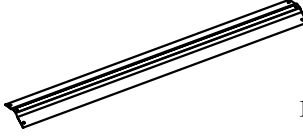

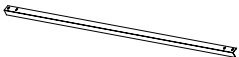
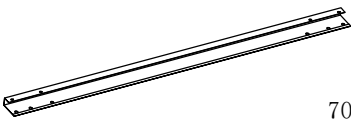
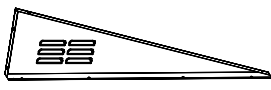
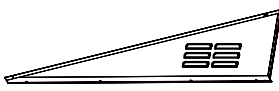

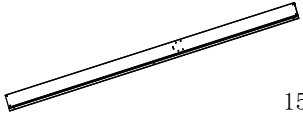

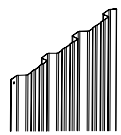
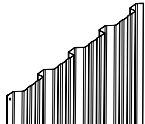

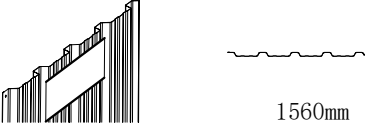

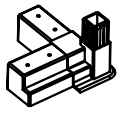

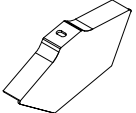

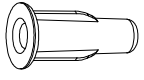

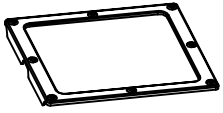

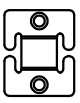
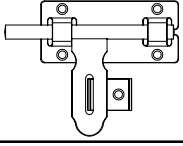
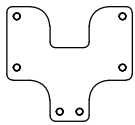
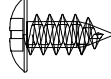
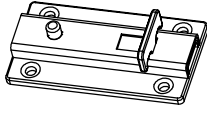

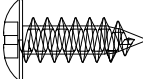

NO.	PART.	Qty.
1	 1630.2mm	1
2	 881.2mm	2
3	 1630.2mm	1
5	 1510mm	4
6	 1643.6mm	1
7	 894.4mm	2
8	 1643.6mm	1
9	 981mm	1
10F	 353mm	1
10B	 353mm	1
11L	 230mm	2
11R	 230mm	2
15	 940.9mm	4
16	 1555mm	2

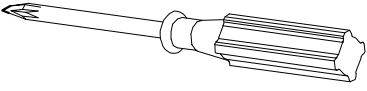
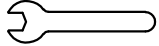
NO.	PART.	Qty.
17L	 1560mm	1
17R	 1560mm	1
18	 1090mm	1
19	 1090mm	2
20	 951mm	4
21	 705mm	4
21L		2
21R		2
22	 1555mm	1
23	 1555mm	1
W1	 1560mm	4
W3	 1560mm	5
W5	 1560mm	2
W7	 1560mm	4

NO.	PART.	Qty.
C1		1
W15		4
M1		2
C		4
F		4
F4		4
F5		2
F7		50
F8		24
F9		2
F15		1
F16		1
F17		1
S1		1

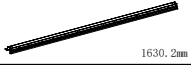

NO.	PART.	Qty.
S2		1
S3		1
S4		202
S5		2
S6		47
S6A		10
S7		51
S8		4
S9		4
S12		1
S15		1
S17		2

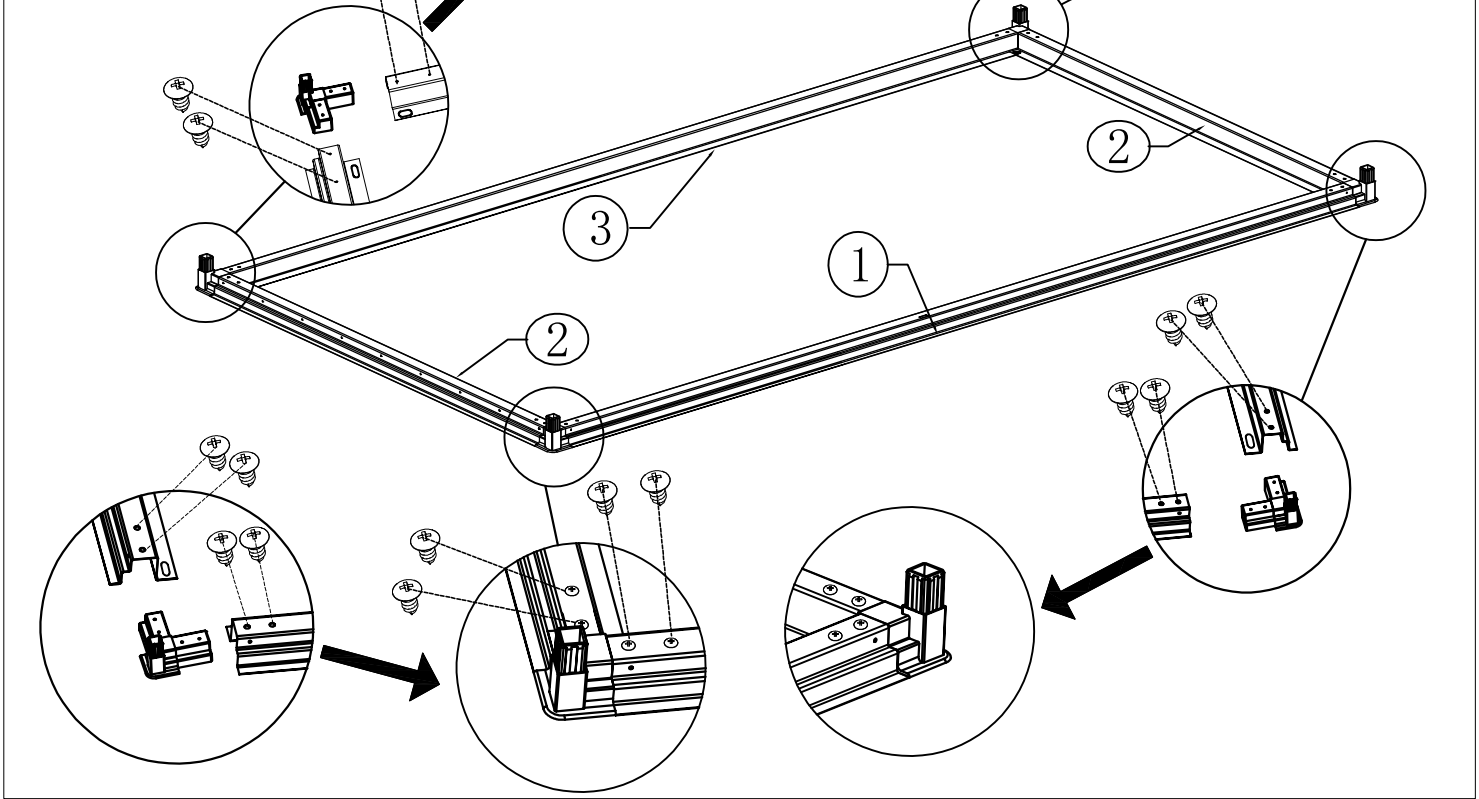
NO.	PART.	Qty.
1	 1630, 2mm	1
2	 881, 2mm	2
3	 1630, 2mm	1
C		4
S4		16



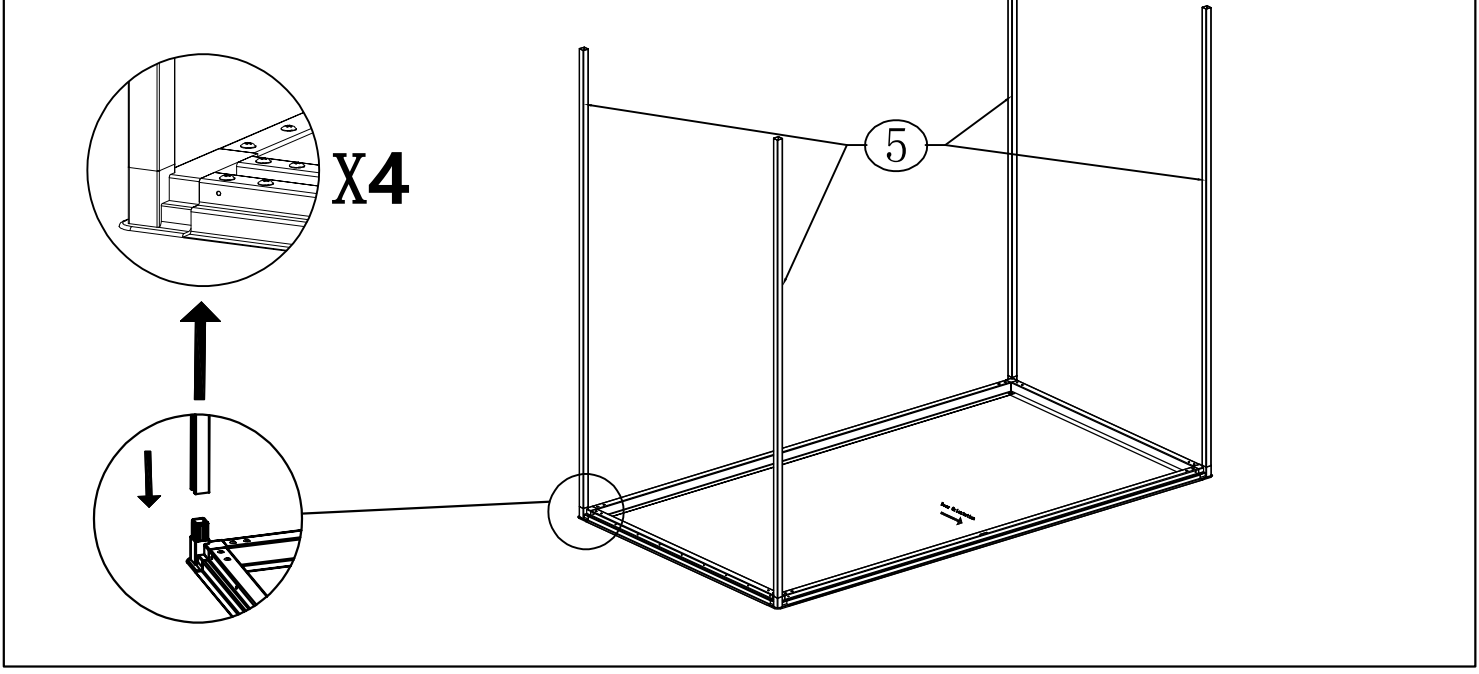

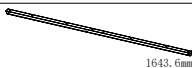
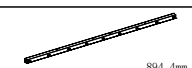
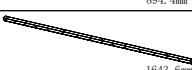

NO.	PART.	Qty.
5	 1510mm	4

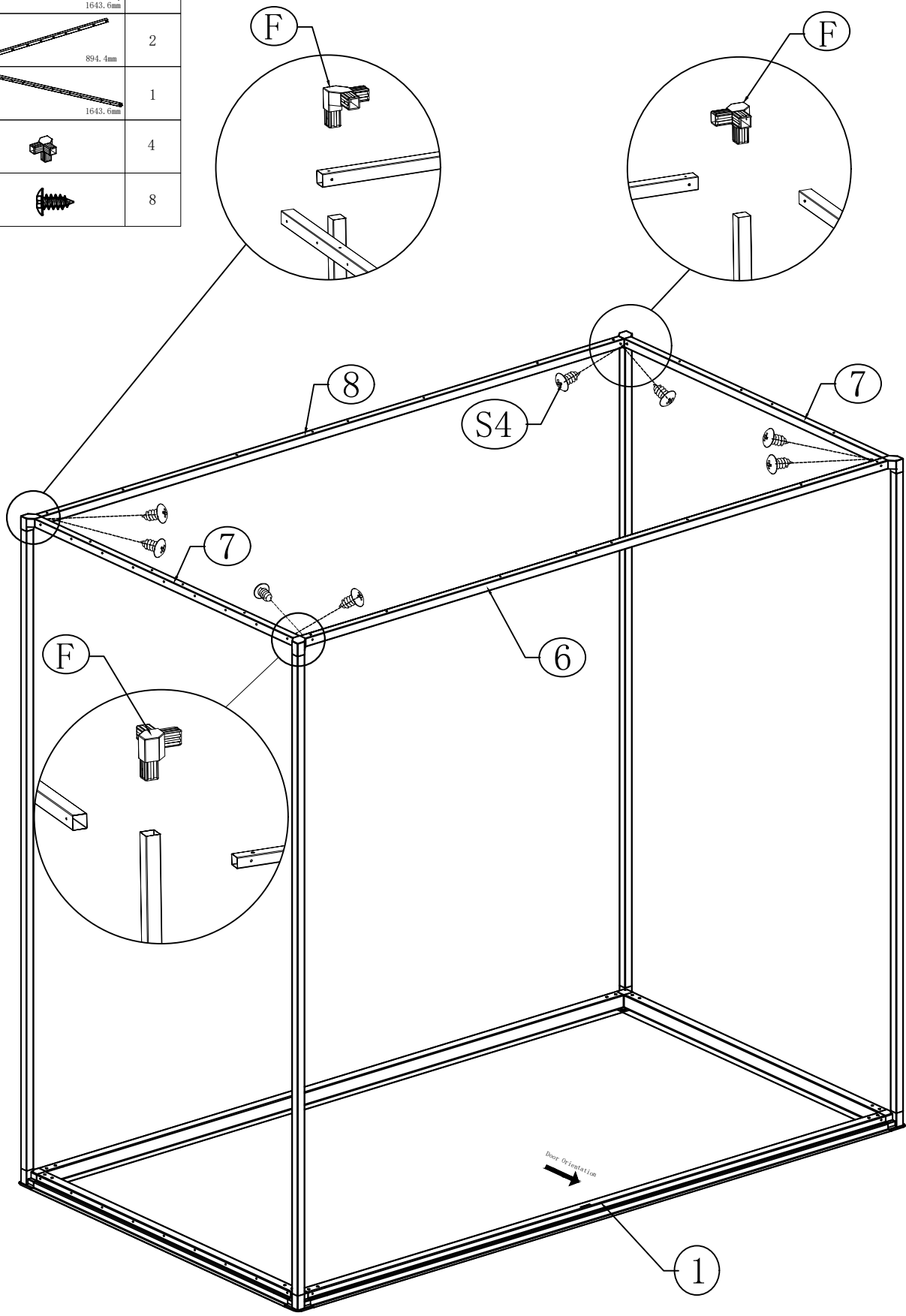





NO.	PART.	Qty.
6	 1643.6mm	1
7	 894.4mm	2
8	 1643.6mm	1
F		4
S4		8

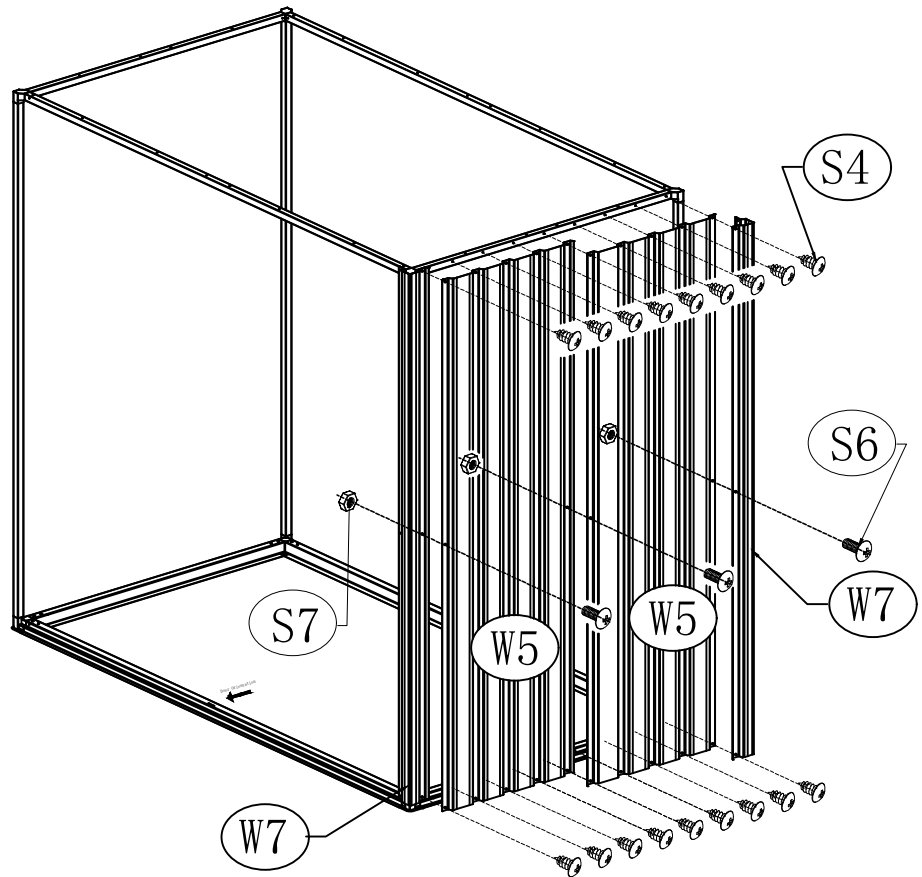





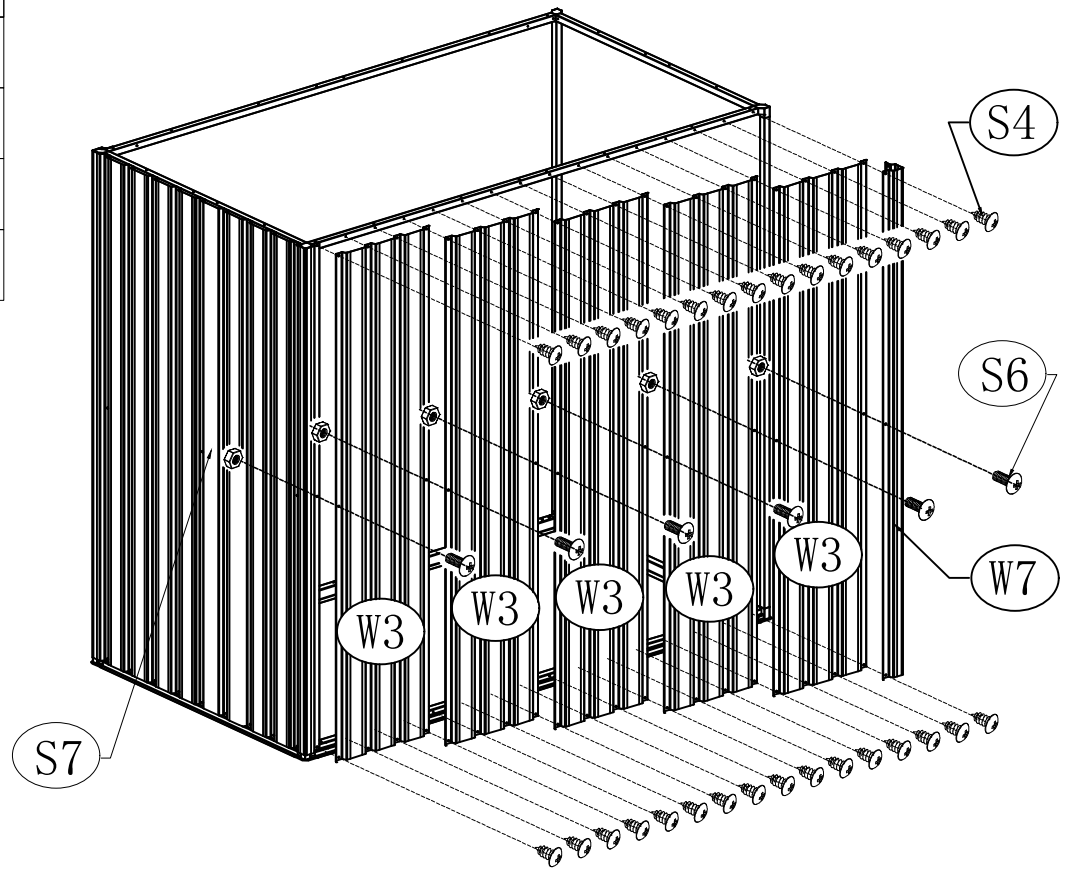

NO.	PART.	Qty.
W7	 2	2
W5	 2	2
S4	 18	18
S6	 3	3
S7	 3	3







NO.	PART.	Qty.
W7	 1	1
W3	 5	5
S4	 32	32
S6	 6	6
S7	 6	6

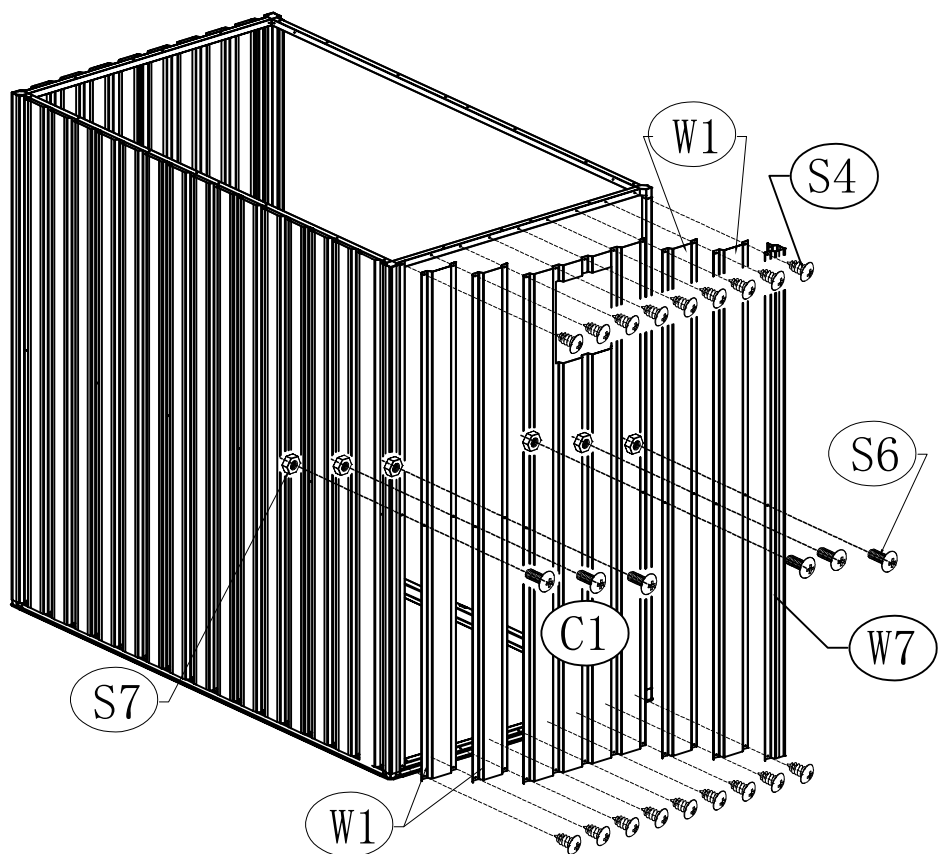





NO.	PART.	Qty.
W7	 1560mm	1
W1	 1560mm	4
C1	 1560mm	1
S4		18
S6		6
S7		6

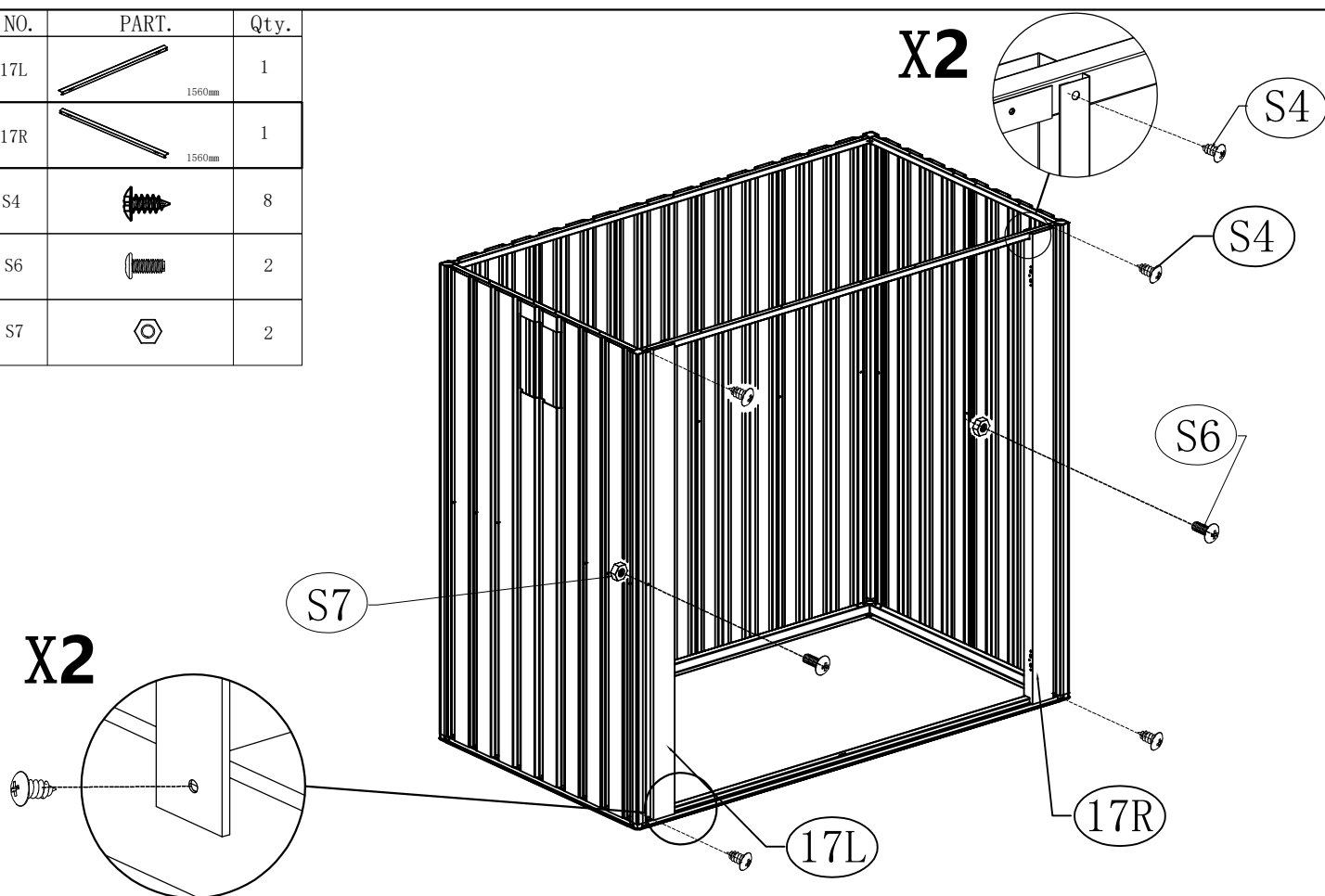







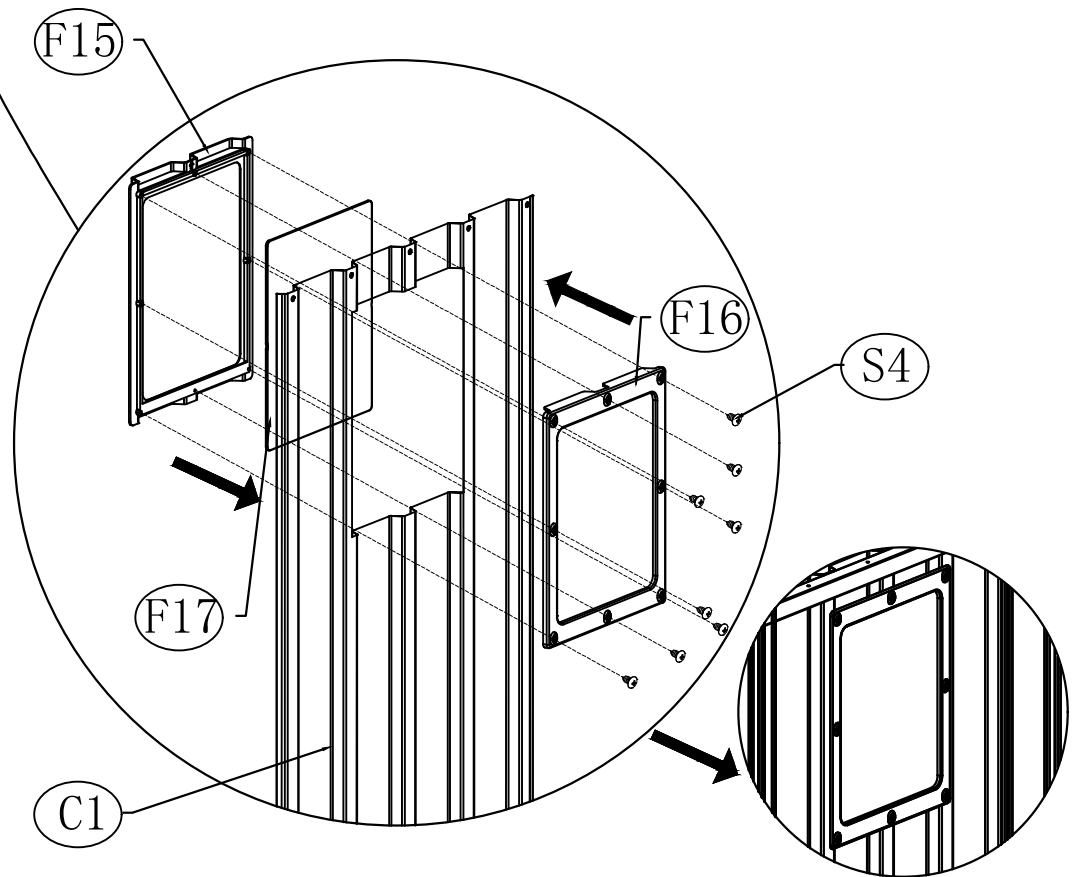
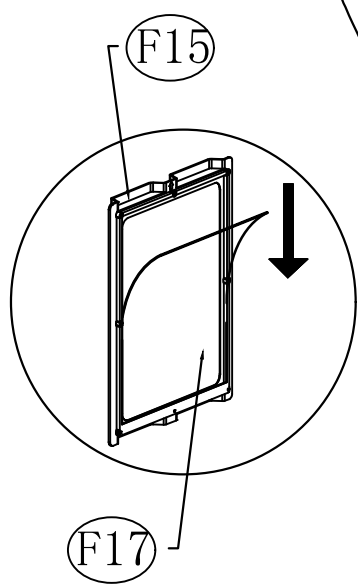
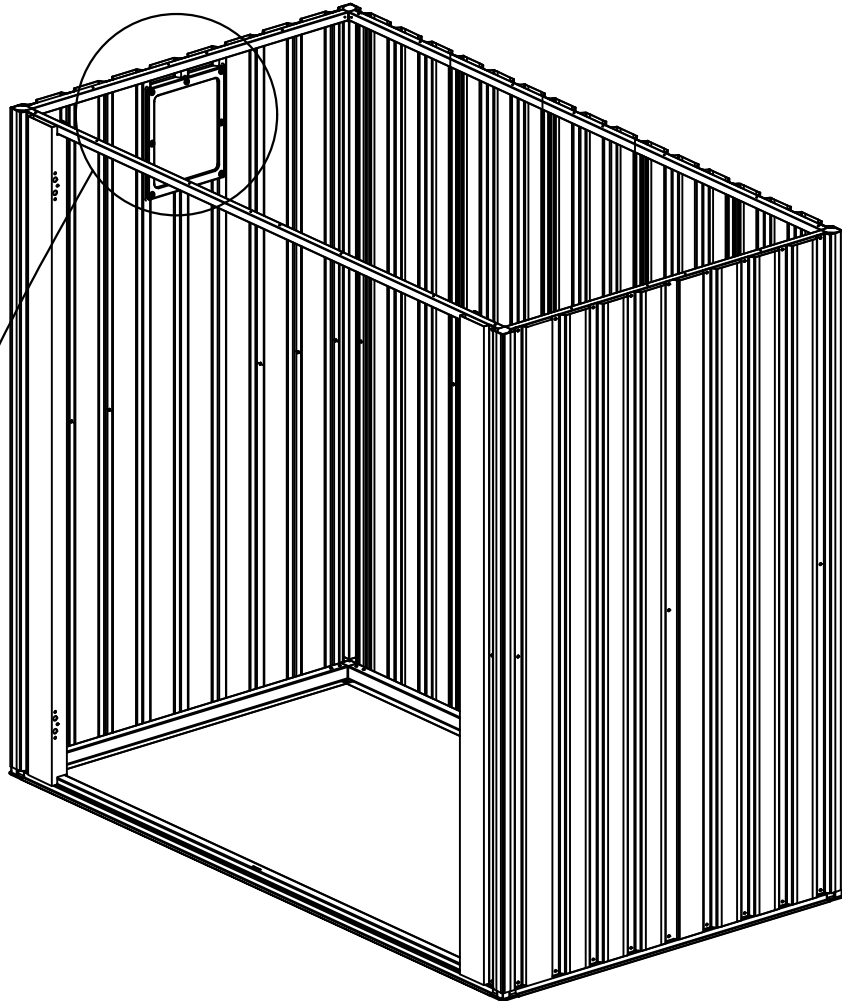

NO.	PART.	Qty.
17L	 1560mm	1
17R	 1560mm	1
S4		8
S6		2
S7		2





NO.	PART.	Qty.
F15		1
F16		1
F17		1
S4		8



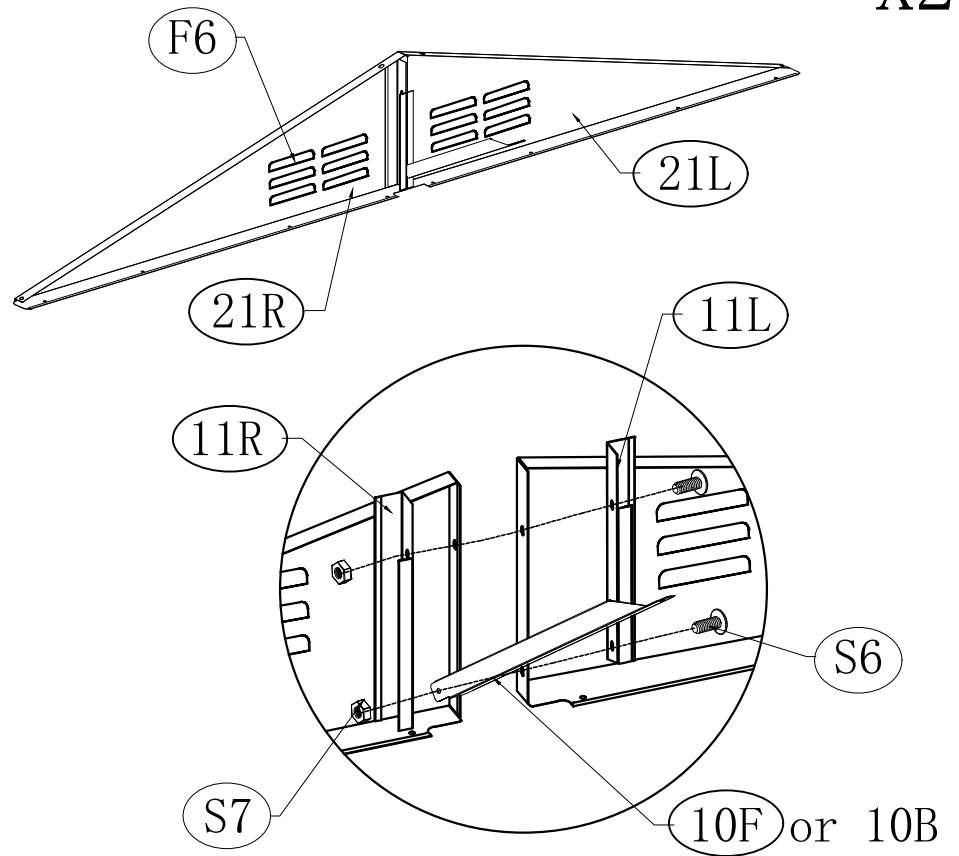

NO.	PART.	Qty.
10F	 353mm	1
10B	 353mm	1
11L	 230mm	2
11R	 230mm	2
21L		2
21R		2
S6		4
S7		4

X2



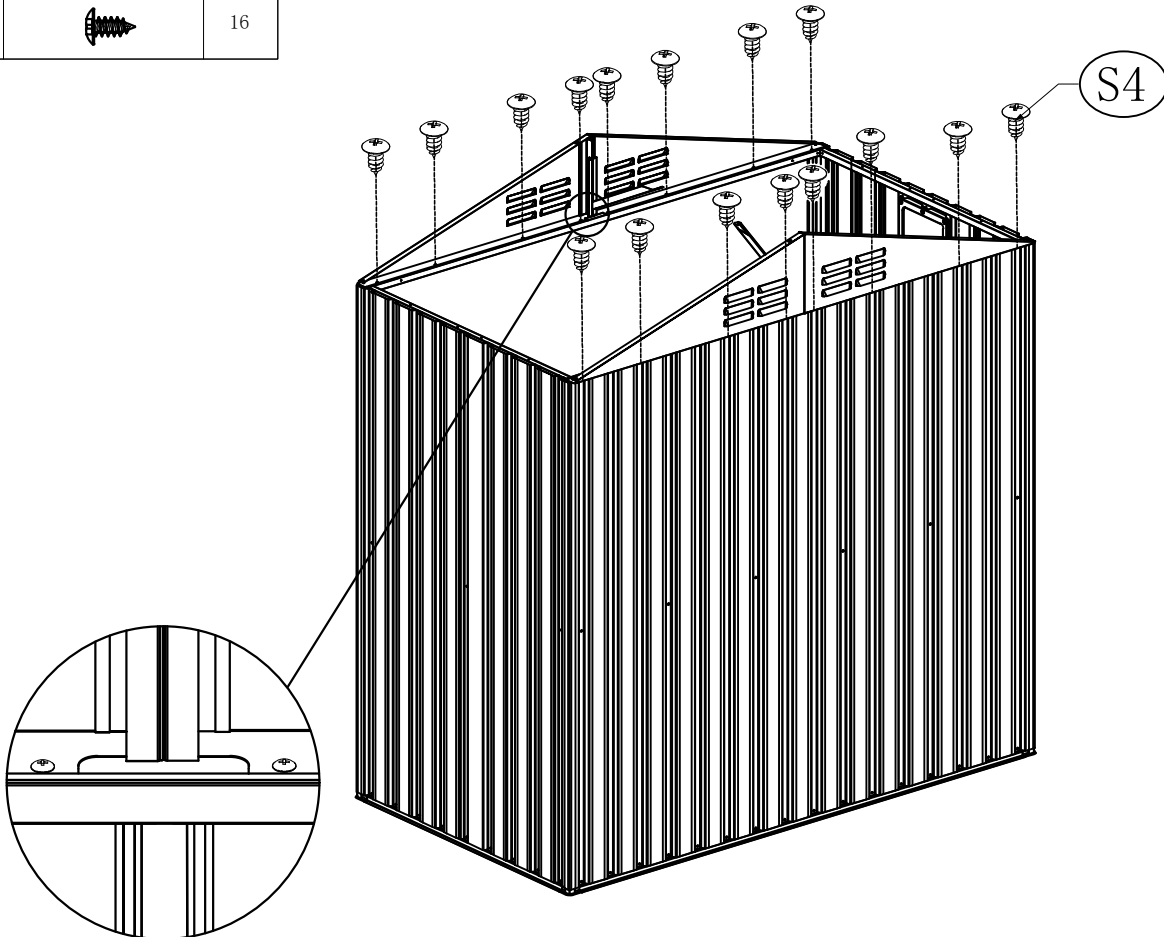

NO.	PART.	Qty.
S4		16



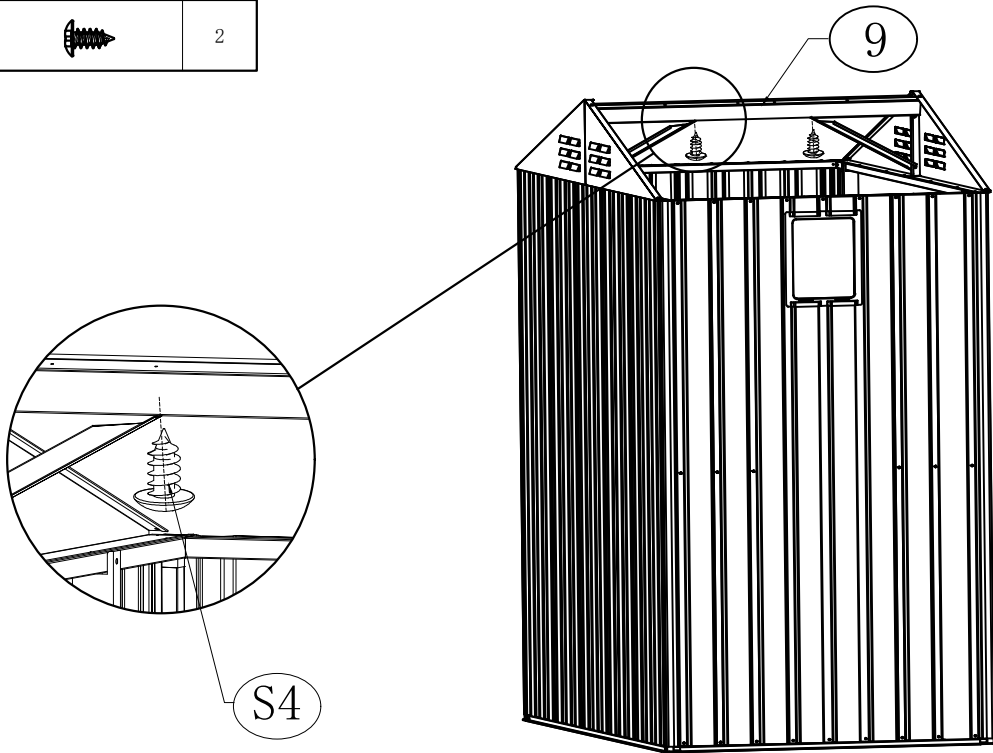



NO.	PART.	Qty.
9	 981mm	1
S4		2



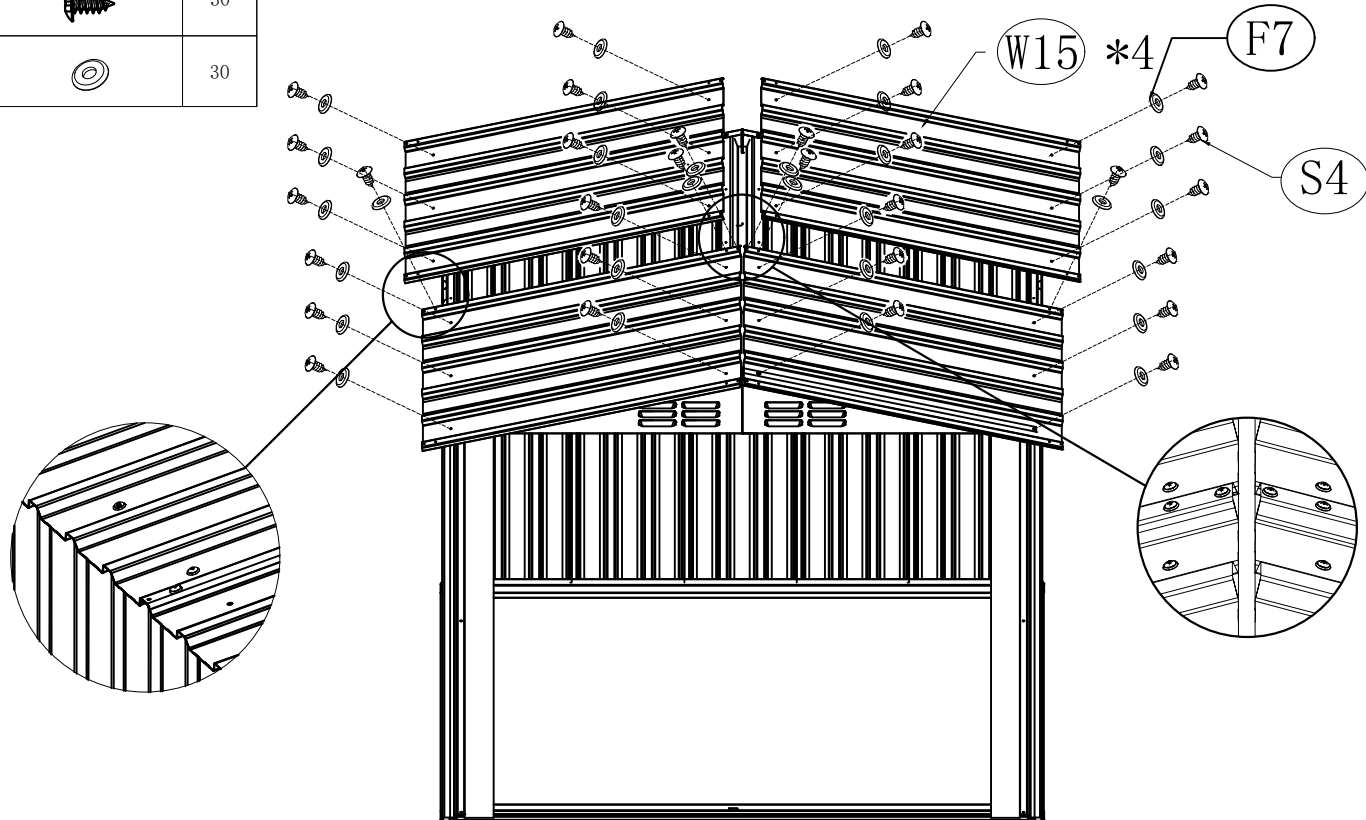



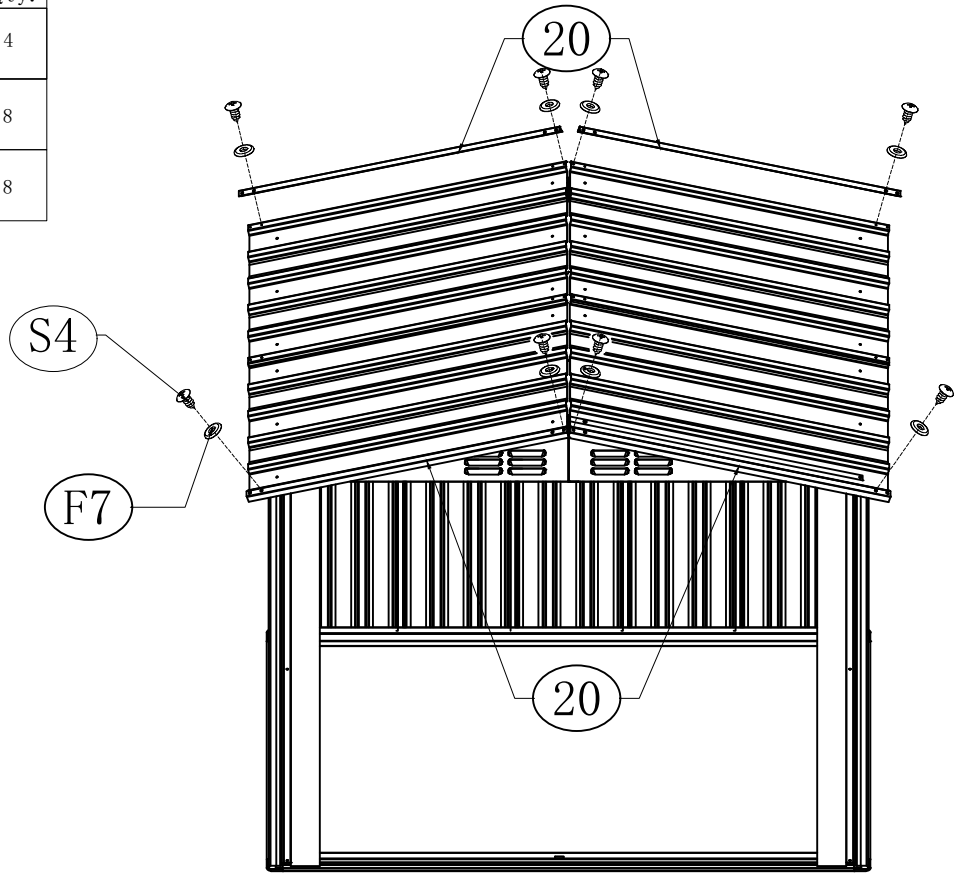

NO.	PART.	Qty.
W15	 943mm	4
S4		30
F7		30

Place the side with small distance between holes and edges on the top



NO.	PART.	Qty.
20	 951mm	4
S4		8
F7		8





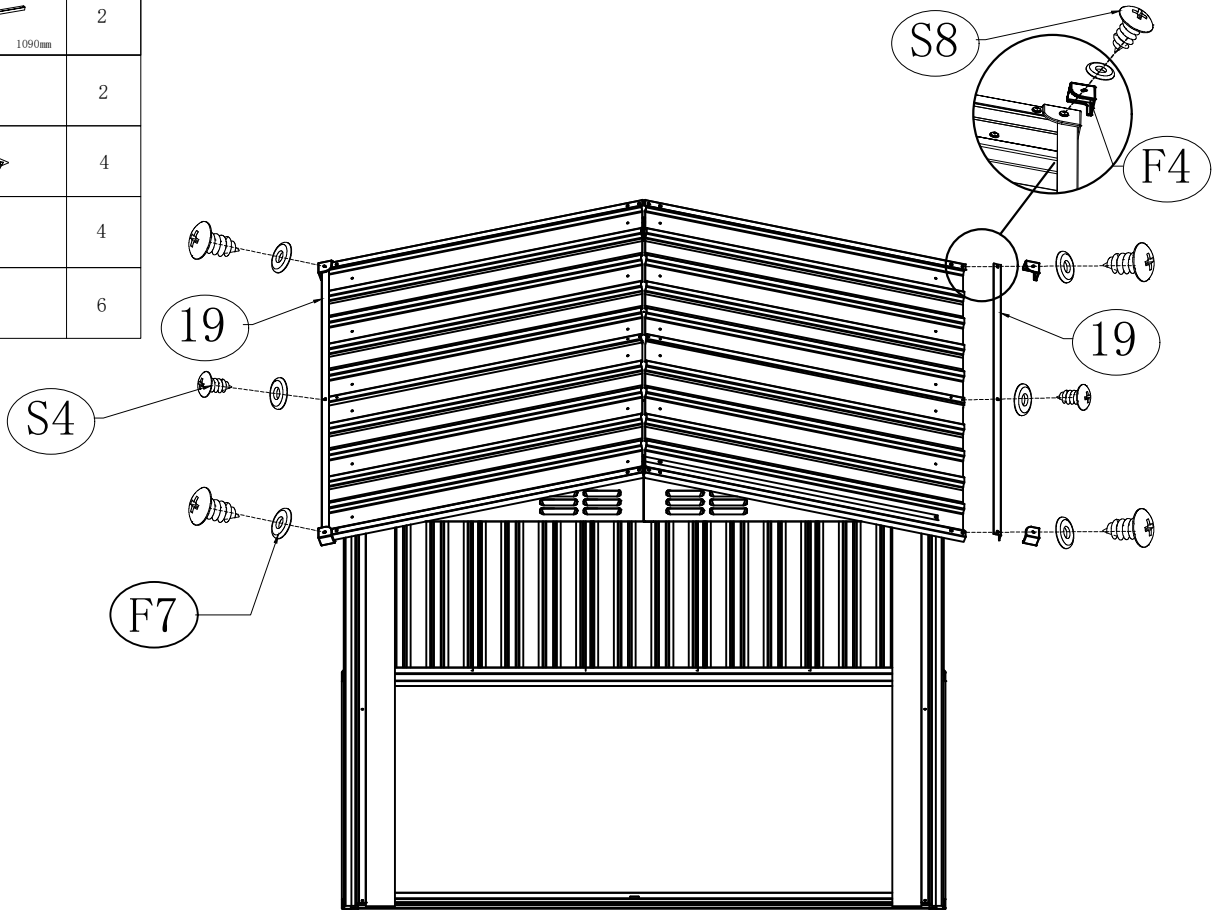

NO.	PART.	Qty.
19	 1090mm	2
S4		2
S8		4
F4		4
F7		6

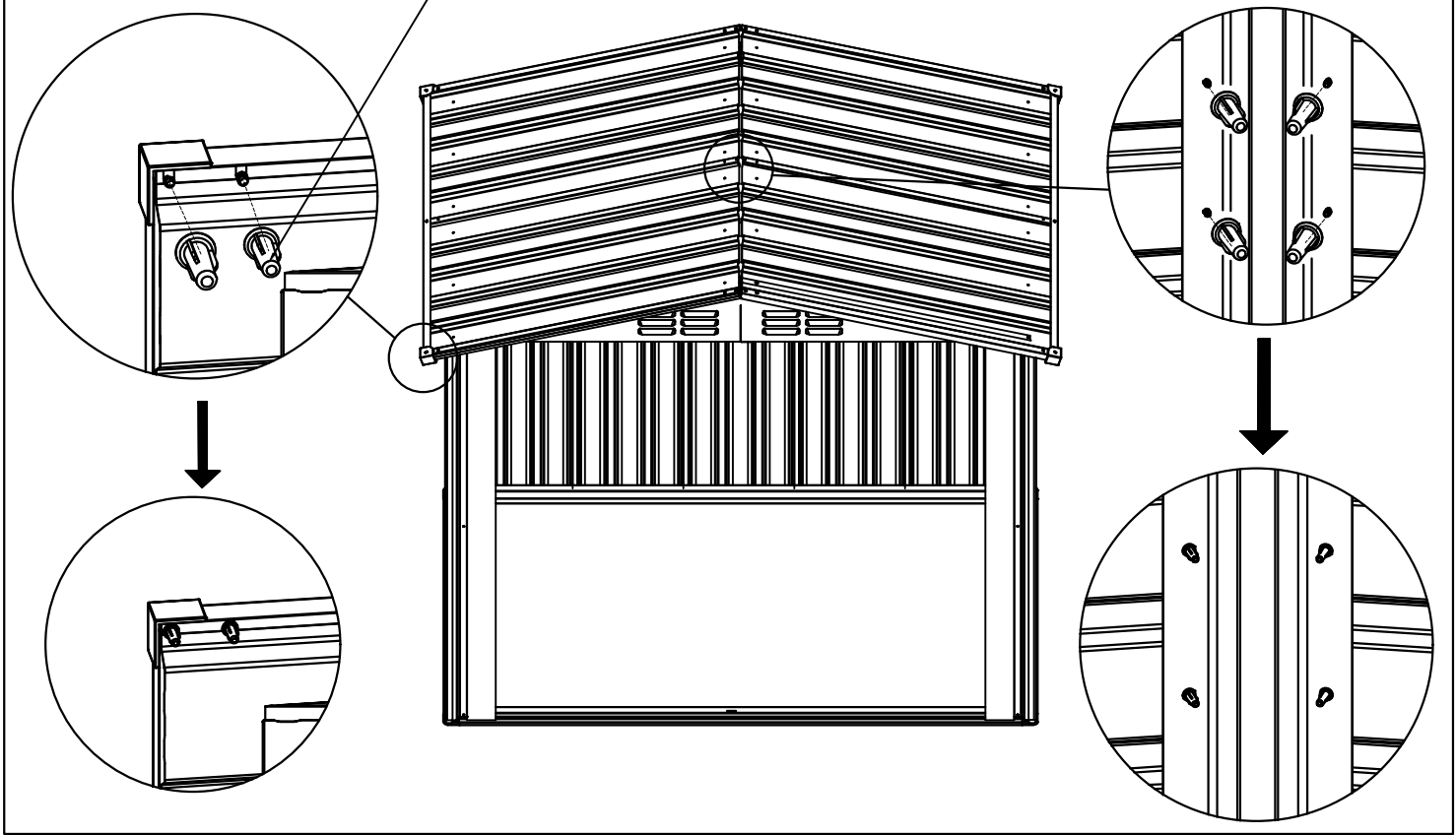







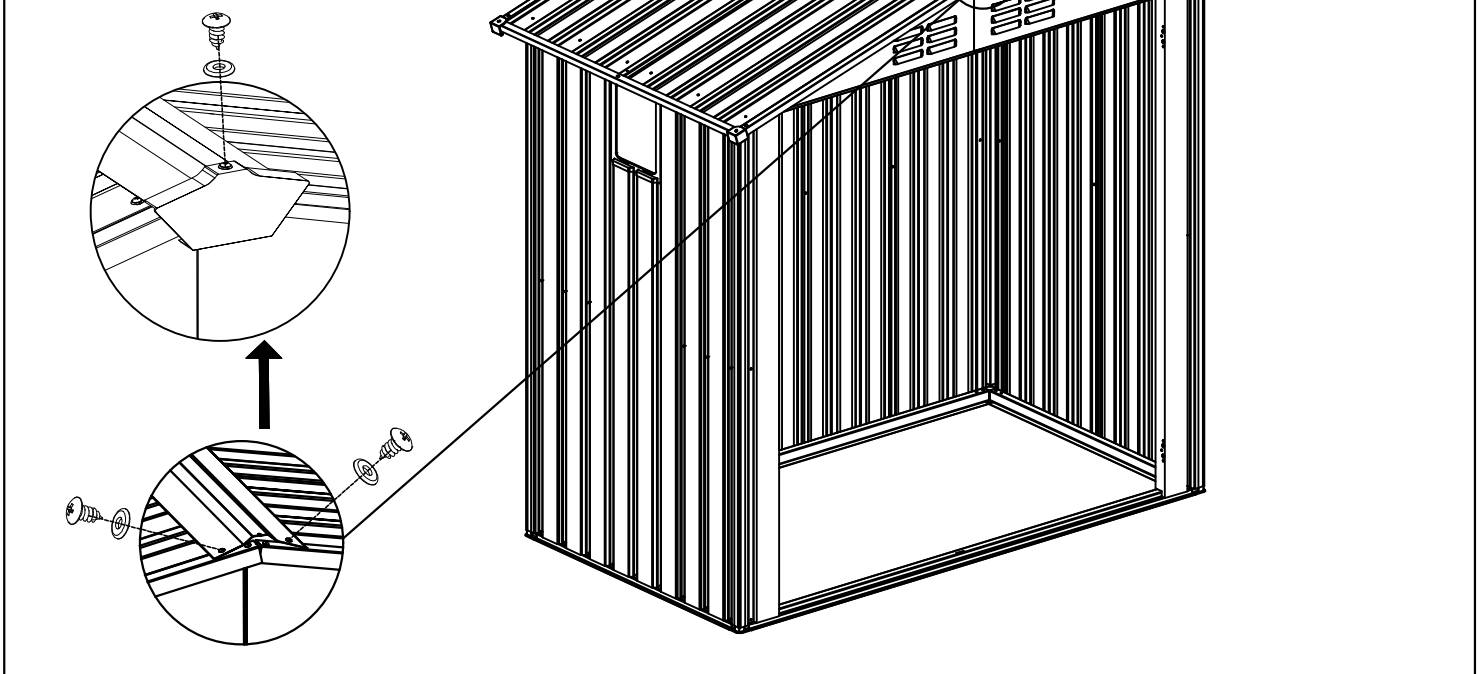

NO.	PART.	Qty.
F8		24



NO.	PART.	Qty.
18	 1090mm	1
F5		2
S4		6
F7		6





NO.	PART.	Qty.
15	 940.9mm	2
16	 1555mm	1
22	 1555mm	1
M1	 1553mm	1
S6		3
S6A		3
S7		6
S1		1

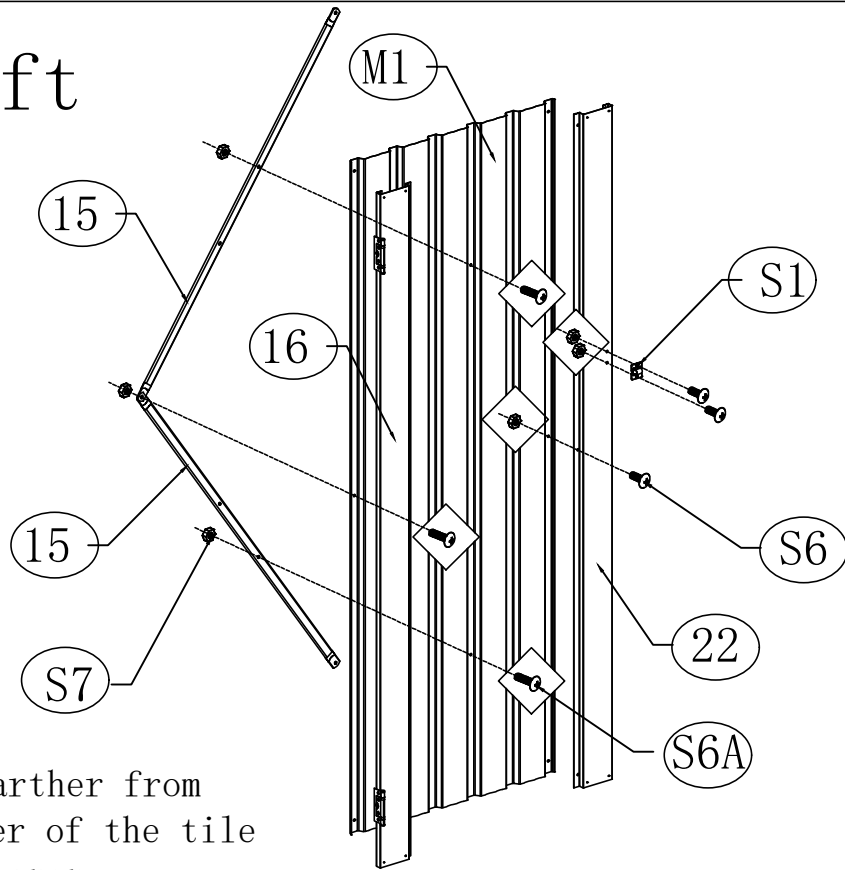



Left



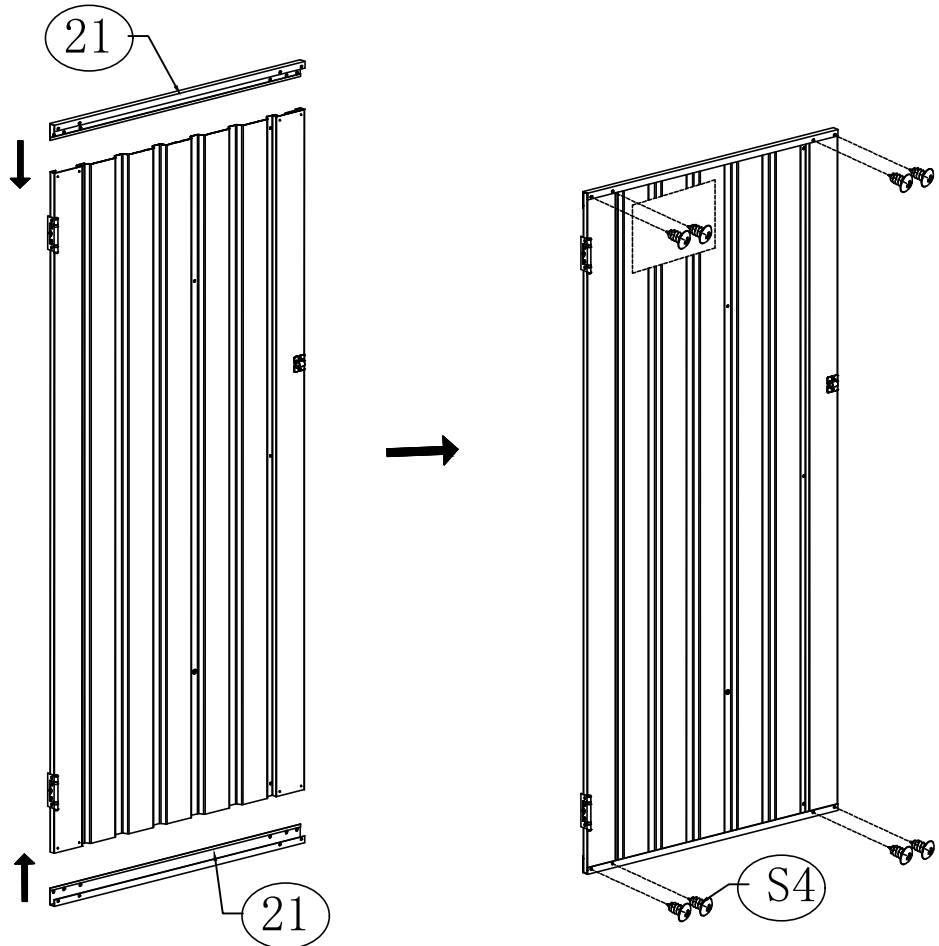





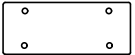

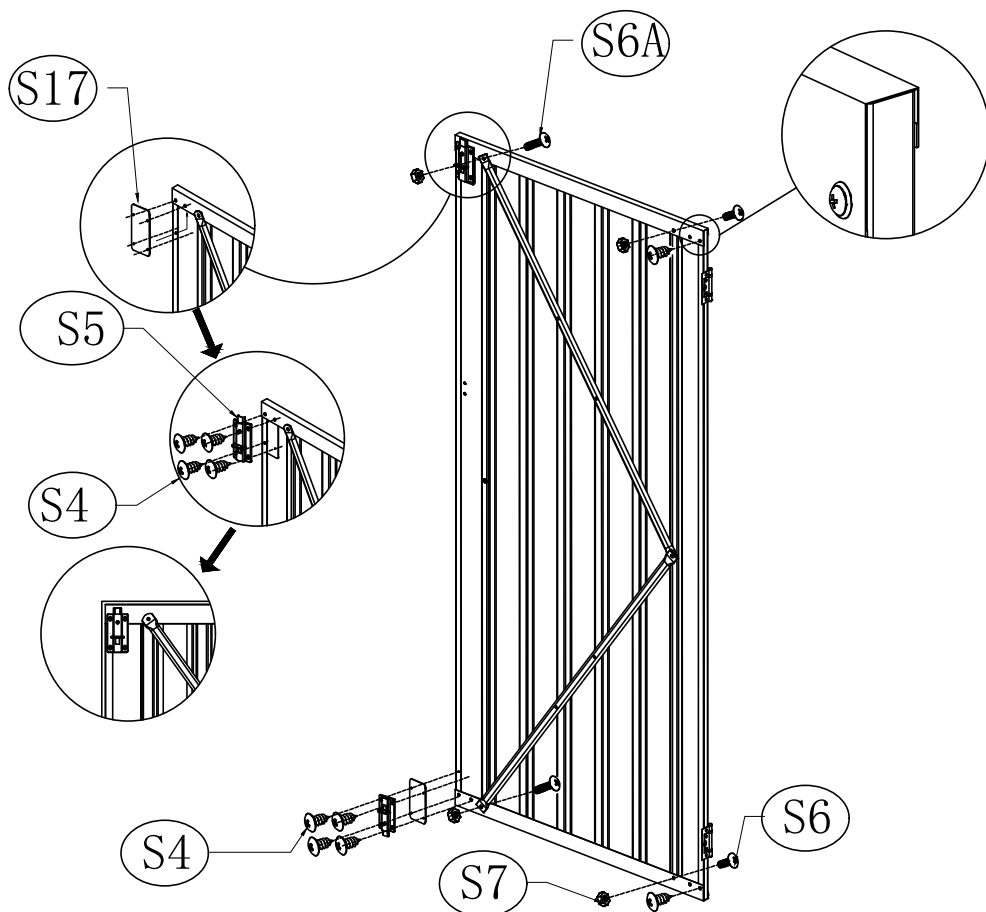

Put 16 on the side farther from the hole in the center of the tile and 22 on the side nearer.

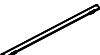
NO.	PART.	Qty.
21	 705mm	2
S4		8

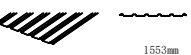

NO.	PART.	Qty.
S4		10
S5		2
S6		2
S6A		2
S7		4
S17		2





NO.	PART.	Qty.
15	 940.9mm	2
16	 1555mm	1
23	 1555mm	1
M1	 1553mm	1
S2		1
S3		1
S6		7
S6A		3
S7		4

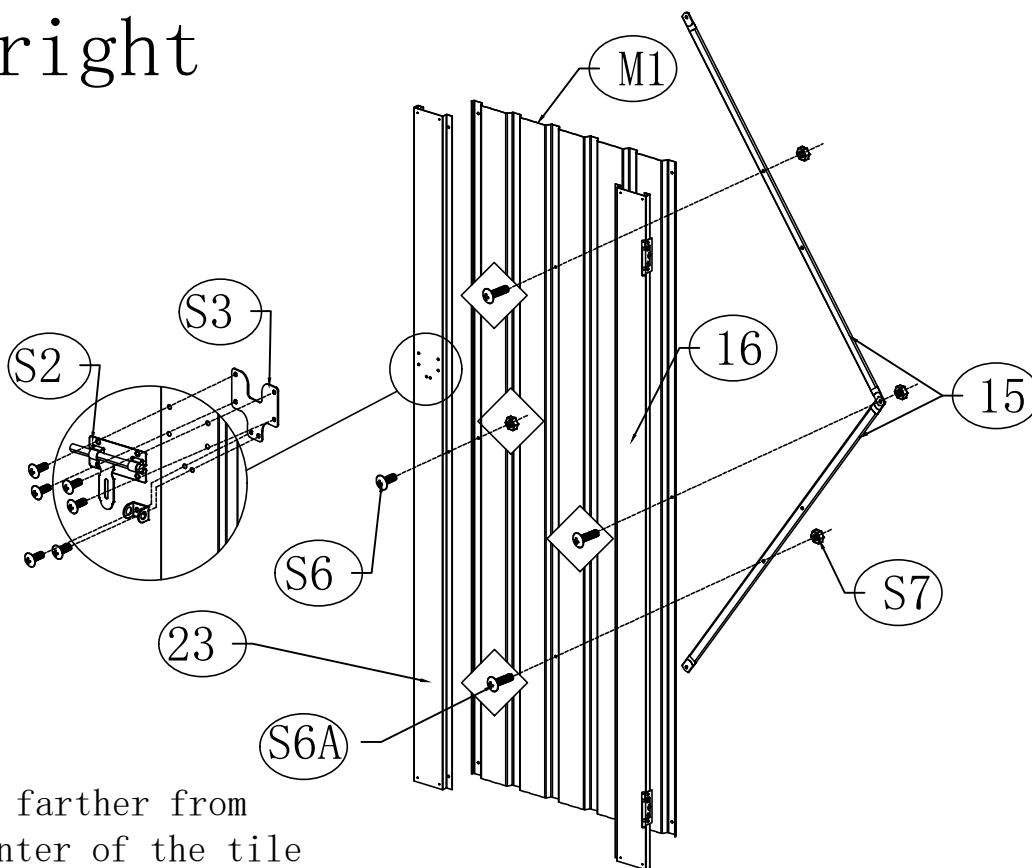



right



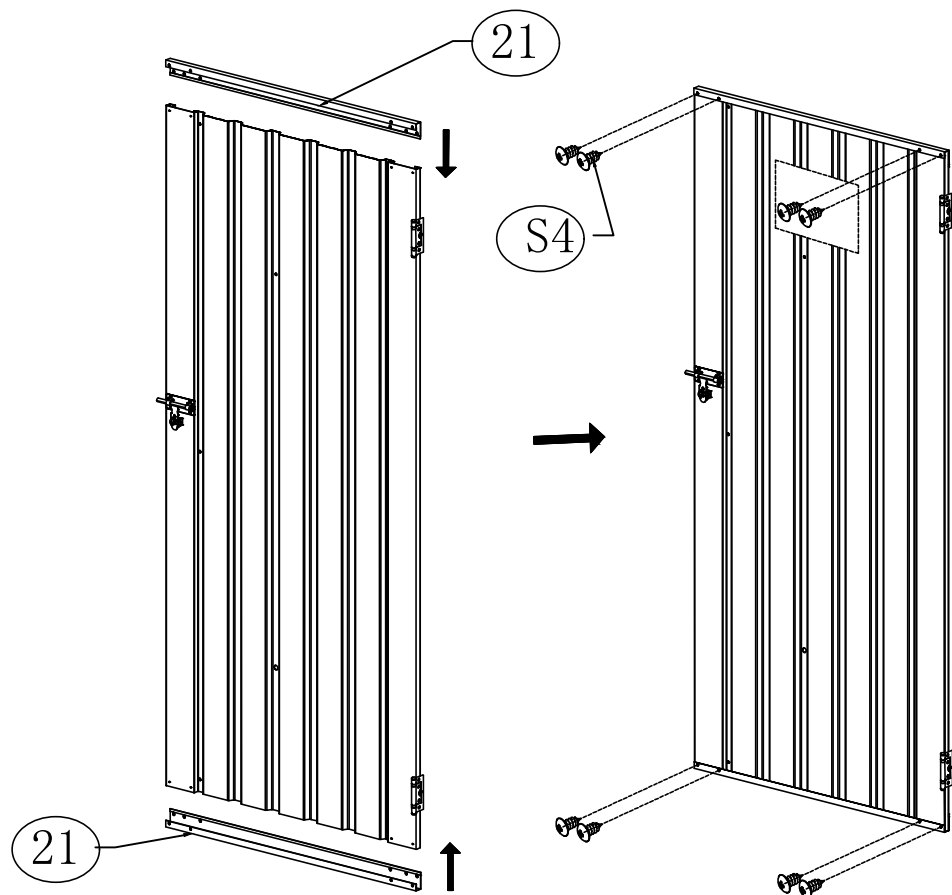

Put 16 on the side farther from the hole in the center of the tile and 23 on the side nearer.

NO.	PART.	Qty.
21	 705mm	2
S4		8

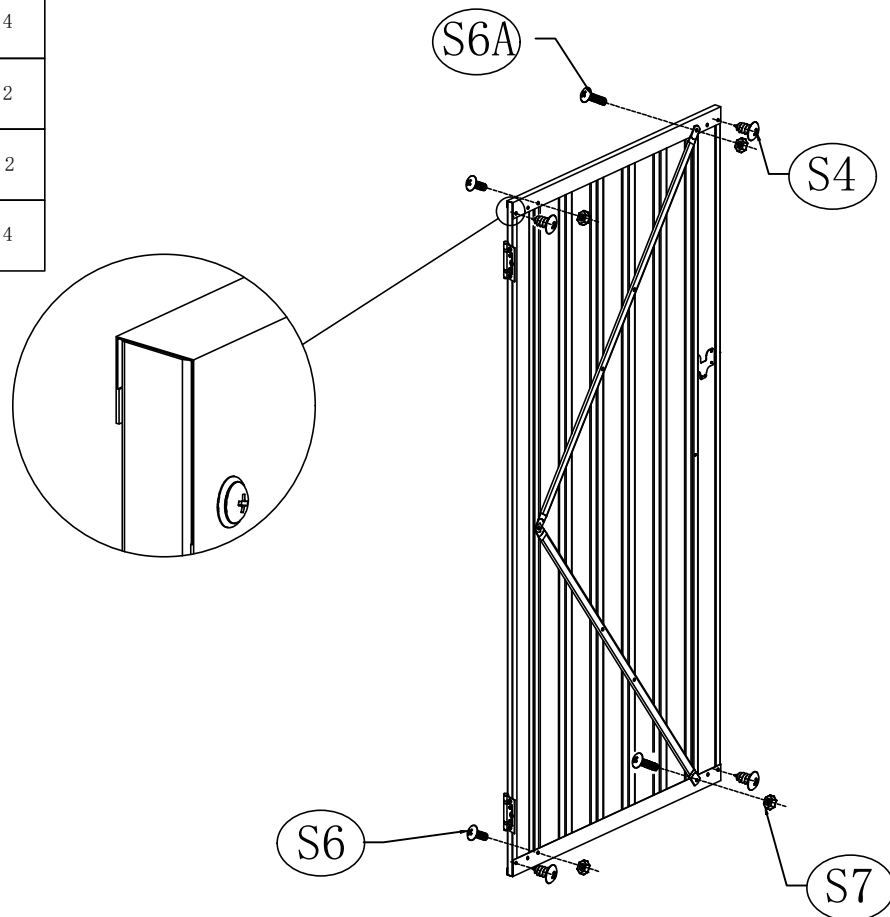

NO.	PART.	Qty.
S4		4
S6		2
S6A		2
S7		4



NO.	PART.	Qty.
S6		12
S7		12

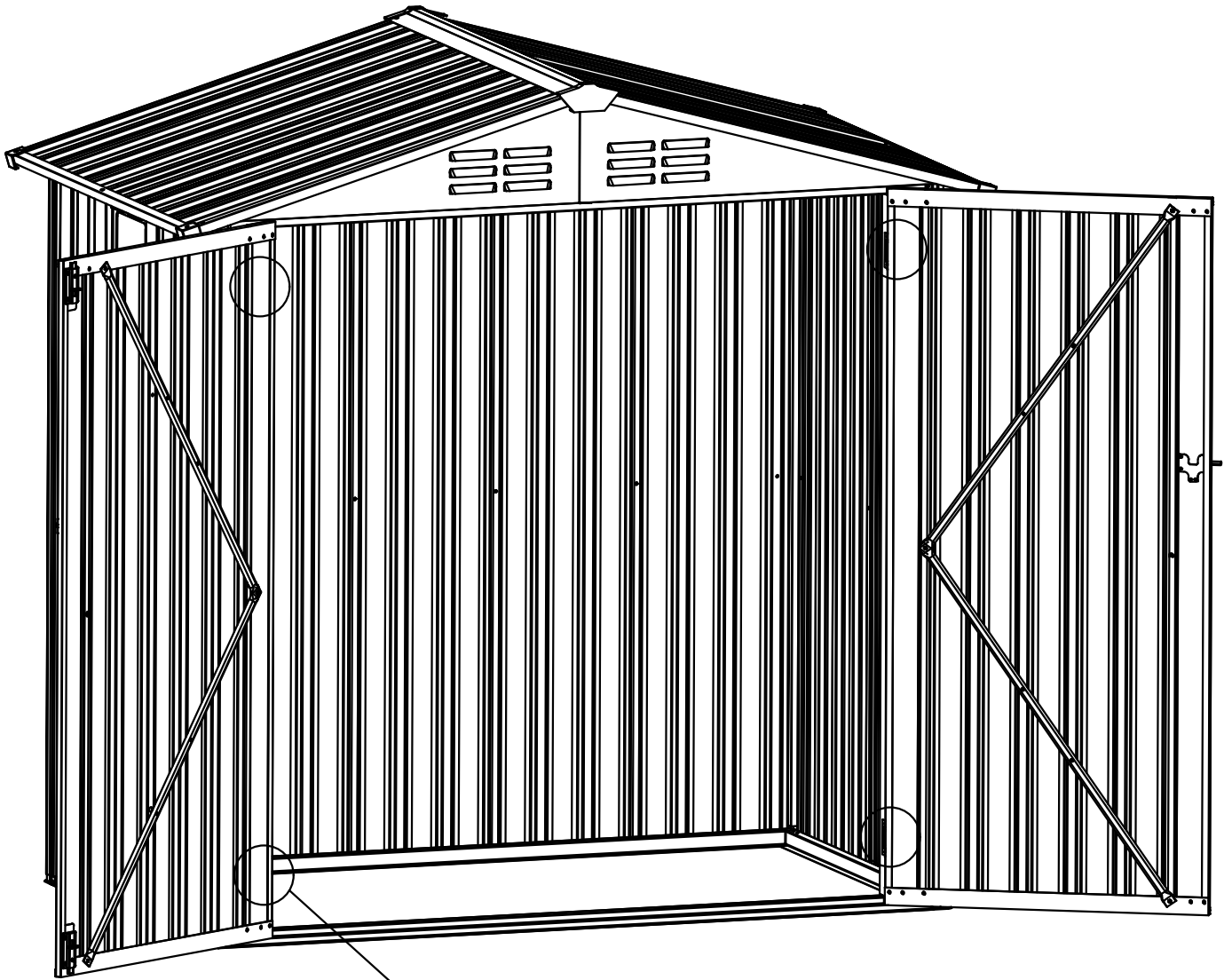

X4

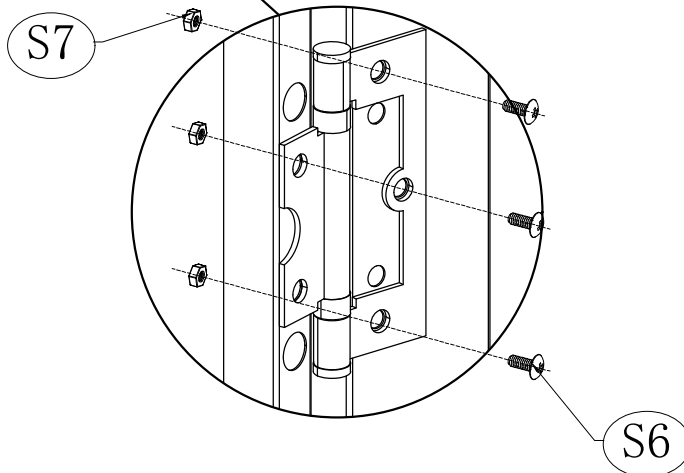

NO.	PART.	Qty.
S9		4

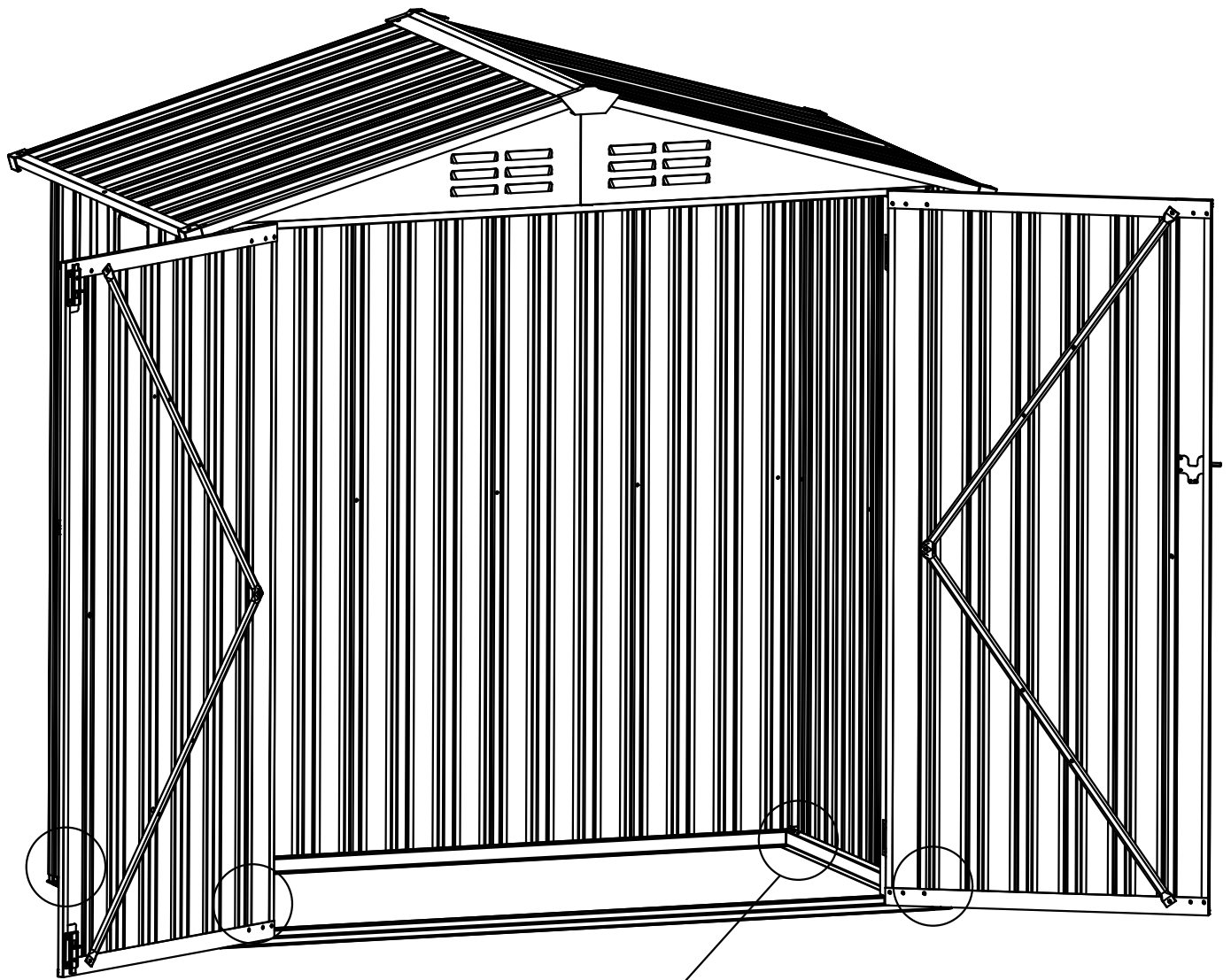

X4

