



# ASSEMBLY INSTRUCTIONS

Item No : T3527-3P







**FLAHERTY 3 PIECE OCCASIONAL SET- 1  
COFFEE & 2 END TABLES**

Thank you for purchasing this quality product. Be sure to check all packing materials carefully for small parts, which may have come loose inside the carton during shipment. Identify and count all items and compare with the PARTS LIST and/or HARDWARE LIST shown below.

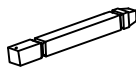

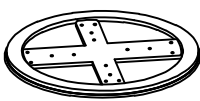
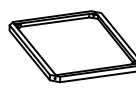
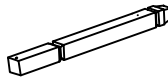

Please read the instructions thoroughly before assembly.

1. We recommend that you assemble this product with the assistance of another person; this will make the assembly easier, and will help eliminate damage to the product or injury to persons during assembly.
2. Please do not tighten screws or bolts until the assembly is completed.
3. To level the chairs or table, before tightening all the screws, the chairs or table must be placed on a flat surface and then tighten the screws.
4. Please put all parts on a non-abrasive floor before assembly and follow the assembly steps to assemble your newly purchased product correctly and efficiently.

### PARTS LIST

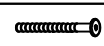
NO.	DESCRIPTION	SKETCH	QTY
A	COFFEE TABLE LEG		4 PCS
B	COFFEE TABLE X-BRACE		2 PCS
C	COFFEE TABLE TOP		1 PC
D	COFFEE TABLE SHELF		1 PC
E	END TABLE LEG		8 PCS
F	END TABLE X-BRACE		4 PCS
G	END TABLE TOP		2 PCS
H	END TABLE SHELF		2 PCS

### HARDWARE LIST

NO.	DESCRIPTION	SKETCH	QTY
1	JCBC Ø0.24" × 2.36"		12 PCS
2	JCBC Ø0.24" × 1.18"		40 PCS
3	SPRING WASHER		28 PCS
4	FLAT WASHER		28 PCS
5	ALLEN KEY		1 PC



New  
Classic®  
FURNITURE

# ASSEMBLY INSTRUCTIONS

Item No : T3527-3P

FLAHERTY 3 PIECE OCCASIONAL SET- 1  
COFFEE & 2 END TABLES

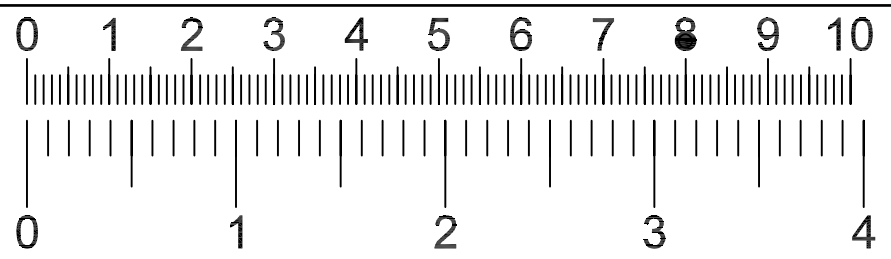

HARDWARE DIMENSIONS  
VERIFICATION TOOL

## STEP 1 : Coffee Table

**PART C** and **B** (Coffee Table X-Brace) need to assemble to **PART A** (Coffee Table Leg) using **HARDWARE 2** (JCBC Ø.4" × 2.36") using the **HARDWARE 5** (ALLEN KEY) as shown.

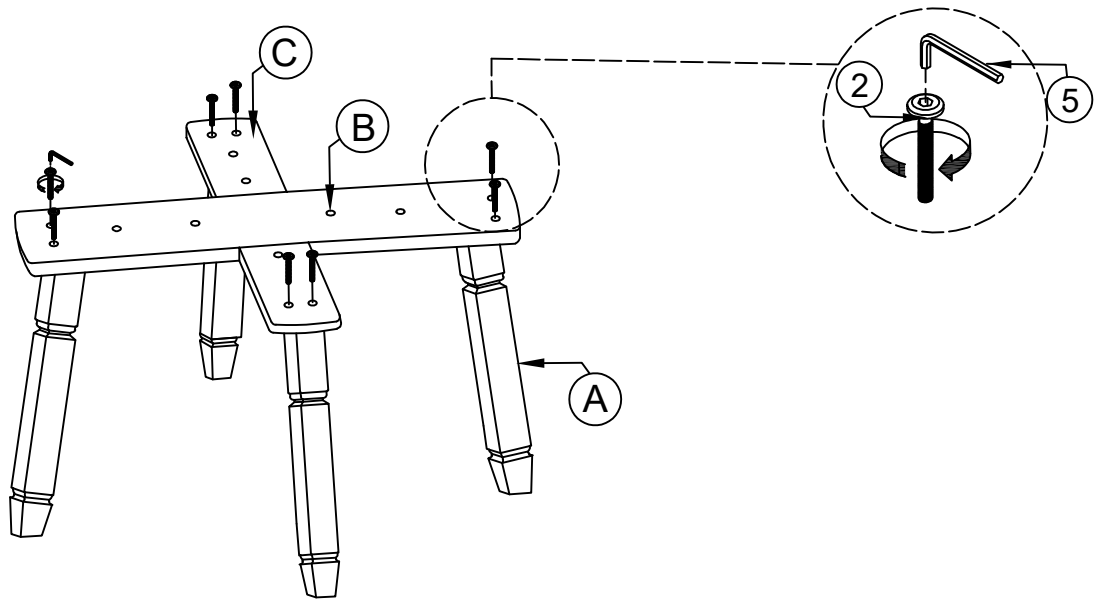

## STEP 2 : Coffee Table

Turn the table updown, **PART E** (Coffee Table Shelf) need to assembly to leg table using a **HARDWARE 4** (Flat Washer), **3** (Spring washer) & **1** (JCBC Ø0.24" × 1.18") using **HARDWARE 5** (Allen Key) as shown.  
After attach, fasten **PART D** (Coffee Table) with Table Leg using **HARDWARE 4** (Flat Washer), **3** (Spring washer) & **2** (JCBC Ø0.24" × 2.36") using the **HARDWARE 5** (Allen key) as shown.

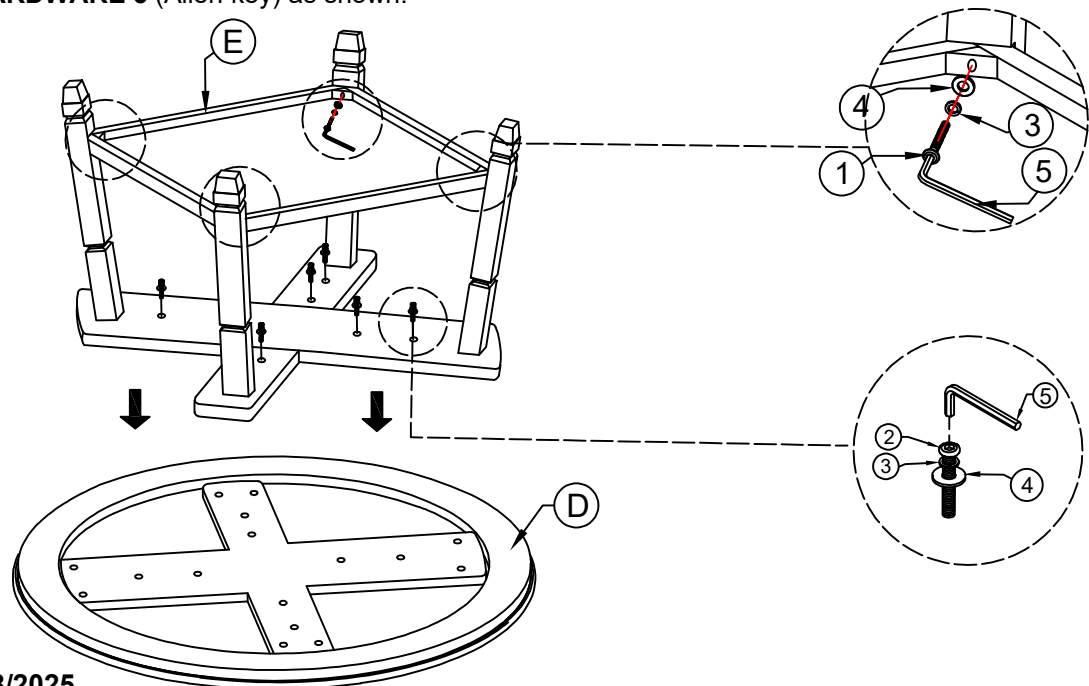



### STEP 3 : Coffee Table

Turn the table upright. Assembly is complete.

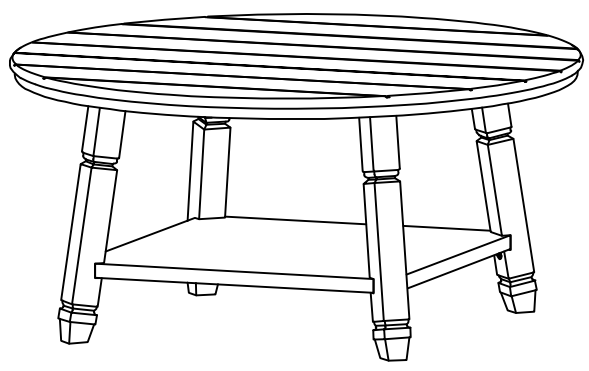

### STEP 4 : End Table

**PART H** and **G** (End Table X-Brace) need to assemble to **PART F** (End Table Leg) using **HARDWARE 2** (JCBC Ø.4" × 2.36") using the **HARDWARE 5** (ALLEN KEY) as shown.

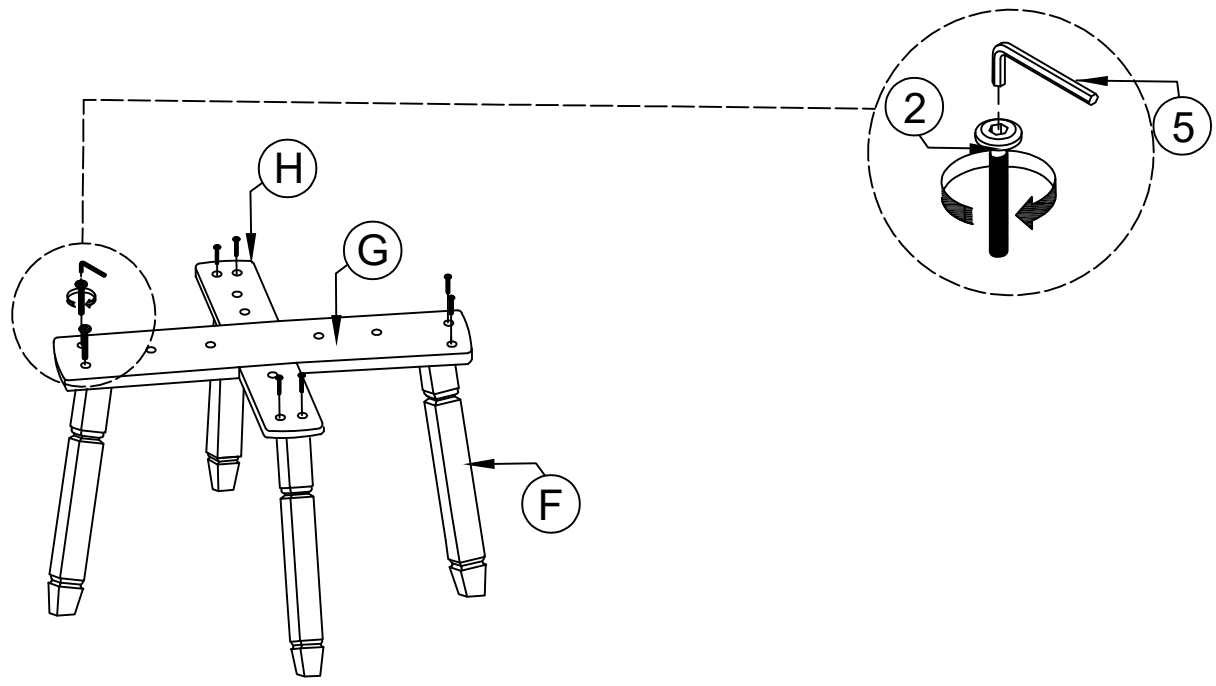



### STEP 5 : End Table

Turn the table updown, **PART J** (End Table Shelf) need to assembly to leg table using a **HARDWARE 4** (Flat Washer),**3** (Spring washer) & **1** (JCBC Ø0.24" × 1.18") using **HARDWARE 5** (Allen Key) as shown. After attach, fasten **PART I** (End Table) with Table Leg using **HARDWARE 4** (Flat Washer),**3** (Spring washer) & **2** (JCBC Ø0.24" × 2.36") using the **HARDWARE 5** (Allen key) as shown.

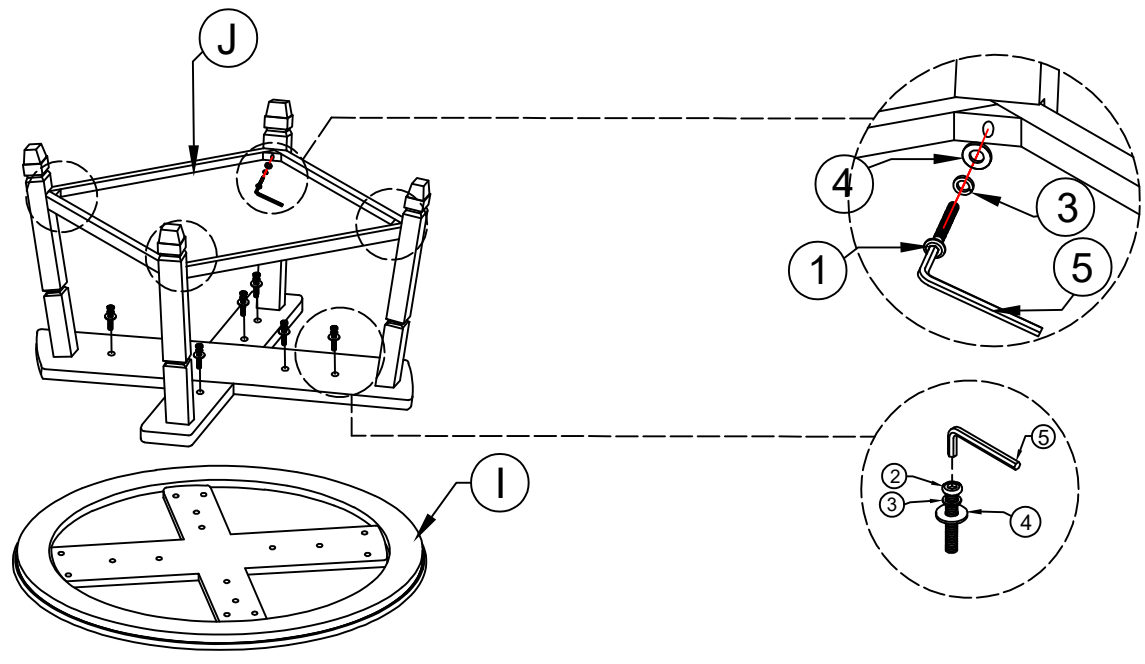

### STEP 6 : End Table

Turn the table upright. Assembly is complete.

