

INSTRUCTION MANUAL

Bar Arm Chair

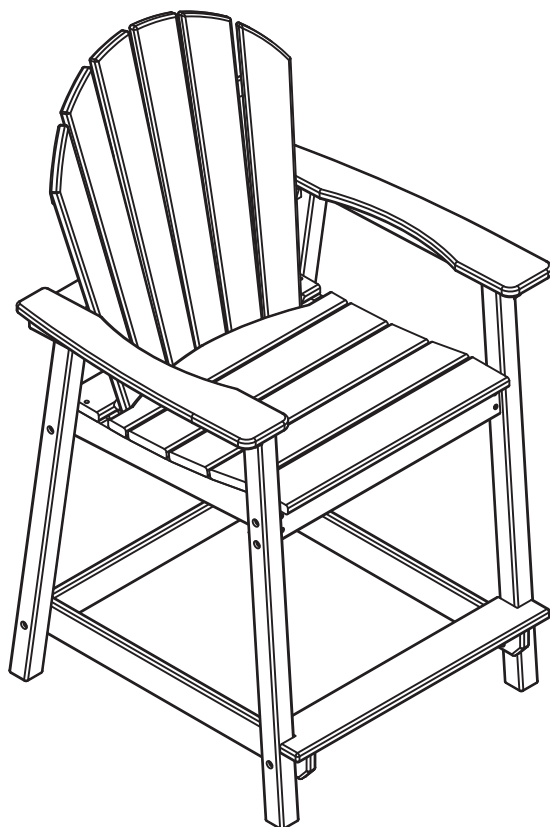

CONTENTS

1. INTRODUCTION	01
2. PREPARATION	02-05
2.1 Precaution	
2.2 Assembly Instruction	
2.3 Part List	
3. INSTALLATION STEPS	06-12
4. COSTOMER SERVICE	13-14

Bar Arm Chair

We are committed to providing consumers with high-quality outdoor furniture so that they can enjoy a comfortable and high-quality living experience in their outdoor spaces. Our mission is to allow people to have a comfortable, secure and wonderful life experience while being in close contact with nature outdoors.

ATTENTION:

Please exercise caution when unpacking the product with sharp tools to avoid inadvertently cutting the balcony chair.

Upon opening the package, kindly inspect the contents to ensure all accessories are present and in good condition. If anything is missing or damaged, please contact us through our official email

Before sitting, meticulously secure all bolts, screws, and knobs to ensure the product's stability and safe operation.

For your safety, please adhere to the specified weight limit. Exceeding this limit can compromise the structural stability of the chair.

Under no circumstance should the product be used as a standing or climbing platform. Standing on any part of the product is strictly prohibited.

During assembly, it is imperative to keep children at a safe distance. The package includes small parts that may be hazardous if swallowed or inhaled.

ASSEMBLY INSTRUCTION

Your furniture requires assembly before use. You must read the entire assembly instructions to become familiar with the unit before you set up this product.

Safety Warning and Precautions

WARNING: When setting up your furniture, basic precautions should always be followed to reduce the risk of personal injury and damage to the product.

Read all instructions before assembly and usage of this product:

1. Select an ideal location. Set out all parts on a clear and level surface before assembly. Ideally, the furniture should be set up in the desired location to avoid moving after assembly.
2. Use caution. During all the processes of assembling, especially when lifting heavy or large parts, pay attention to safety.
3. Tools and Assistance. An adjustable spanner is required for assembly. It is recommended that 2 people assist with assembly.
4. Check all parts before assembling, ensure you have all parts detailed in the parts list on Page 4
5. Refer to the assembly diagram. During assembly, refer to the assembly instructions on the following pages.
6. Caution. Keep children away from the work area during assembly. Do not allow children to handle parts or tools while assembling.
7. If you have any questions, please contact us promptly

PART LIST

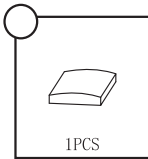
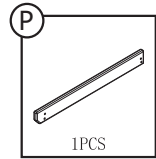
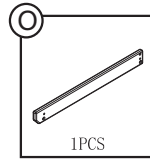
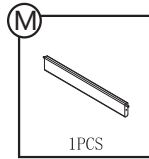
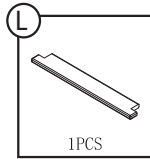
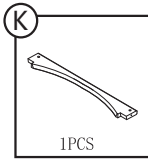
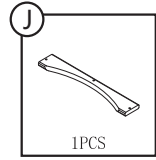
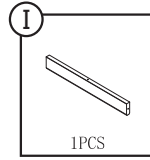
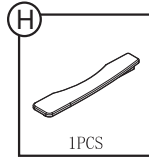
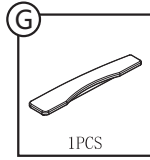
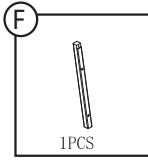
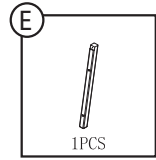
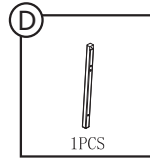
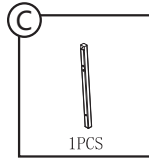
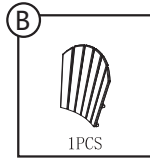
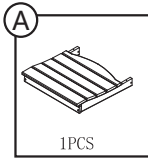

HARDWARE LIST

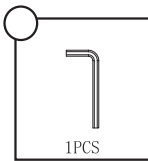
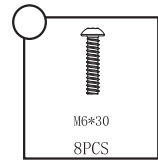
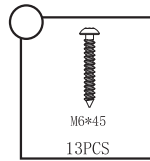
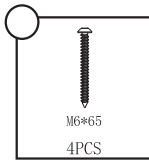
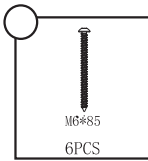

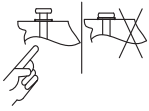

CAUTION: Pre-assemble all the bolts loosely but do not fully turn the bolts into their holes until all bolts are inserted in their holes.

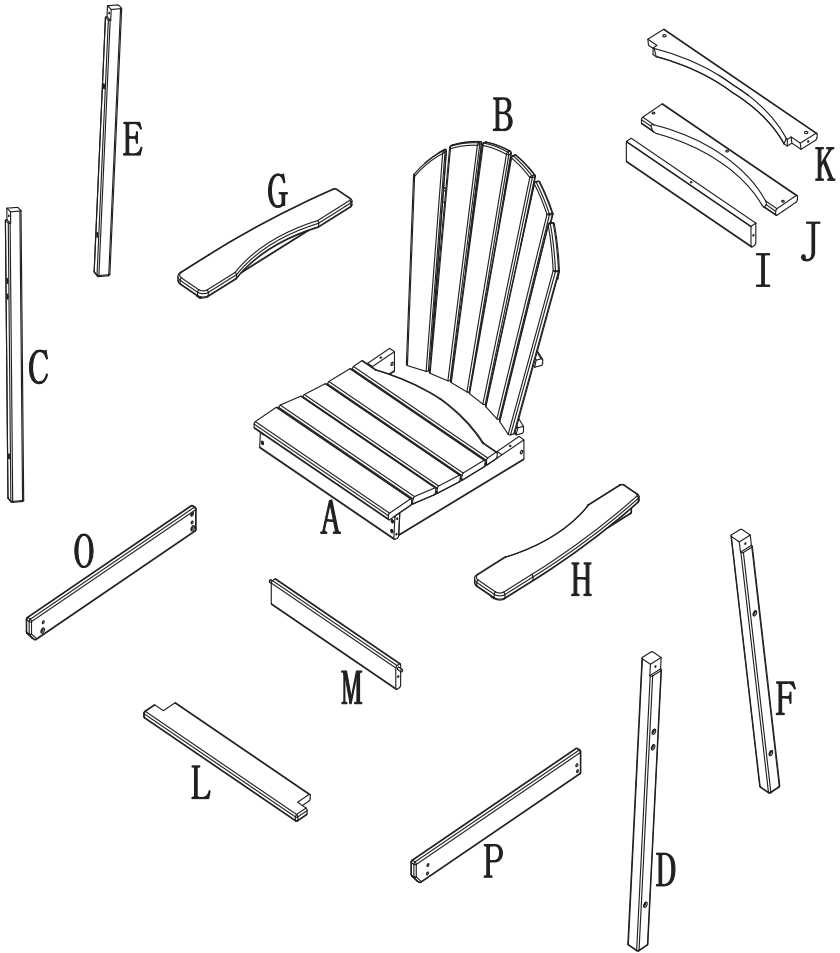
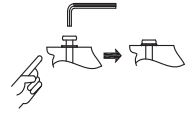

STEP1

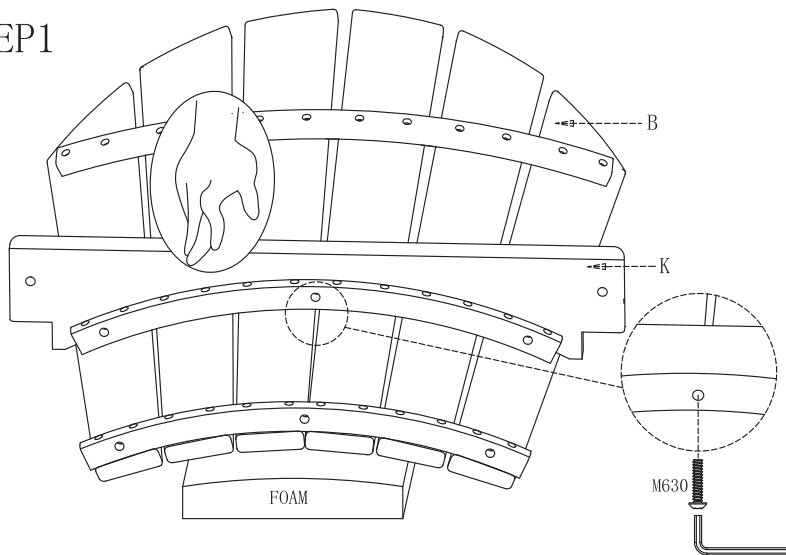

STEP2

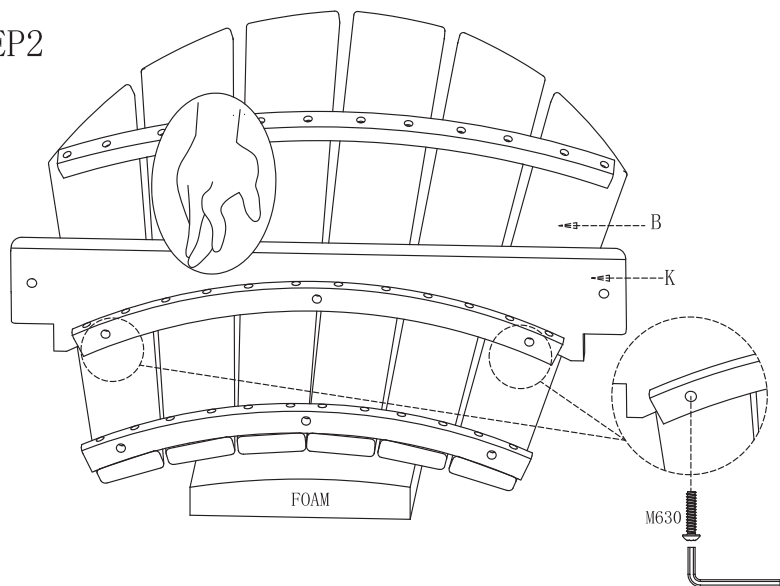

Put the Foam on the bottom as a support. And then press firmly in the middle of (K) to align the screw holes and install it. Attach the Back Panel Support (K) to the Back Panel (B) with Bolt M6*30 (M630) by using Allen Wrench . Install the middle hole first, and then the holes on both sides.

STEP3

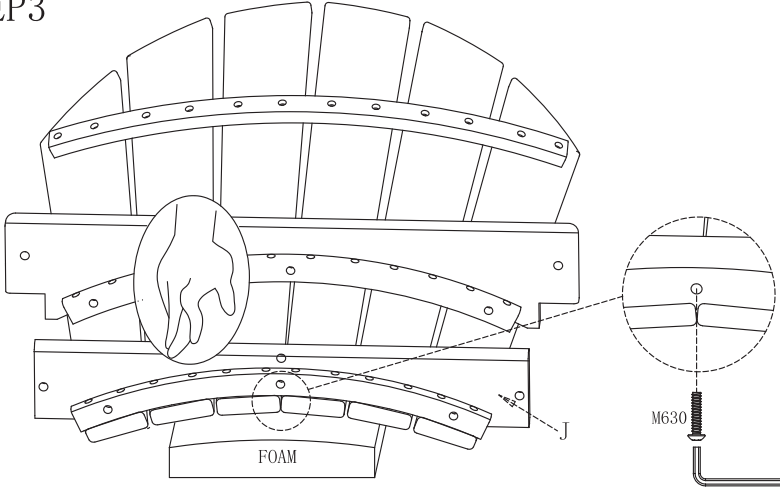

STEP4

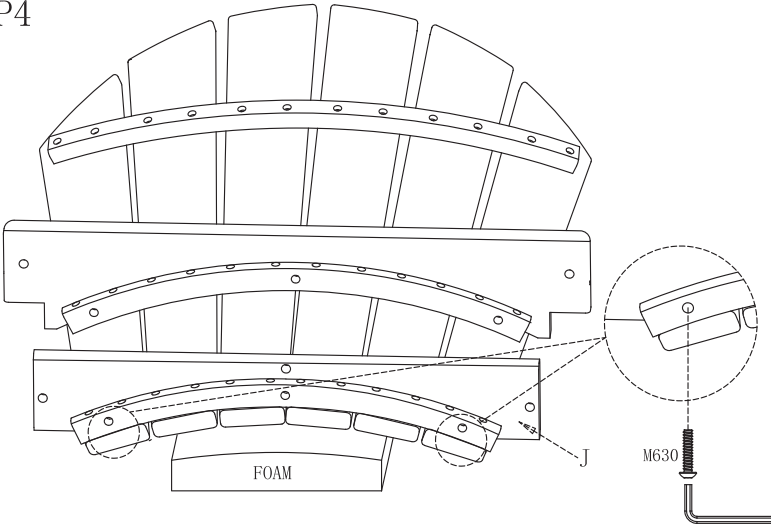

Attach the Back Panel Support (**J**) to the Back Panel (**B**) with Bolt M6*30 (M630) by using Allen Wrench . Install the middle hole first, and then the holes on both sides. Put the Foam Pad on the bottom as a support.

STEP5

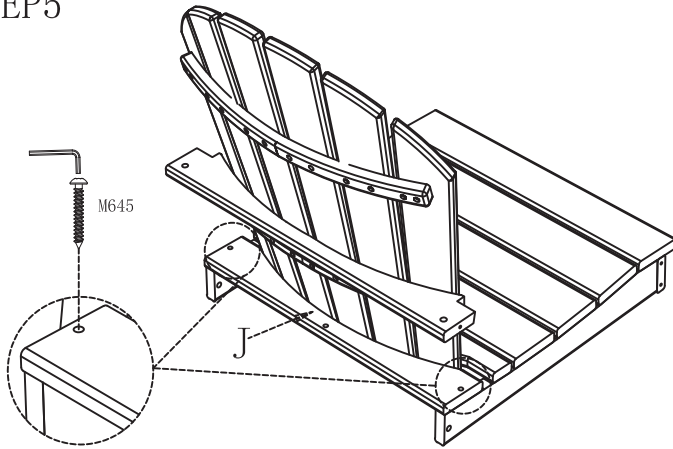

Attach the Back Panel (**B**) to the Seat Panel (**A**) with Bolt M6*45 (M645) by using Allen Wrench .

STEP6

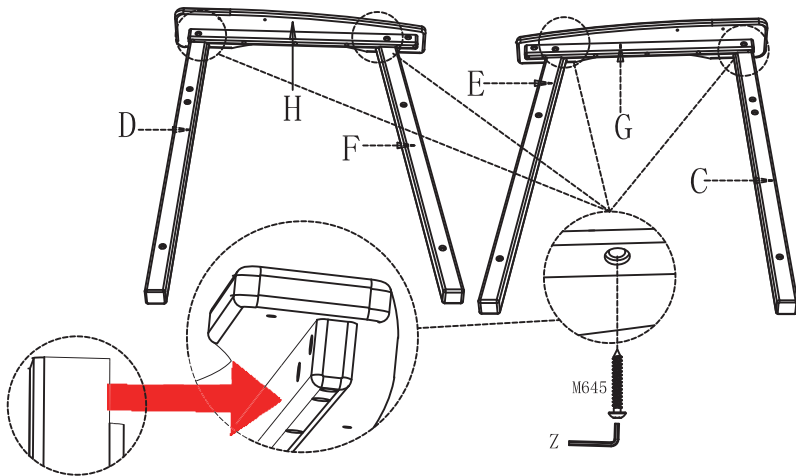

Attach the Right Armrest (**G**) to the (C&E) and the Left Armrest (**H**) to the (F&D) with Screws M6*45 (M645) by using Allen Wrench .

STEP 7

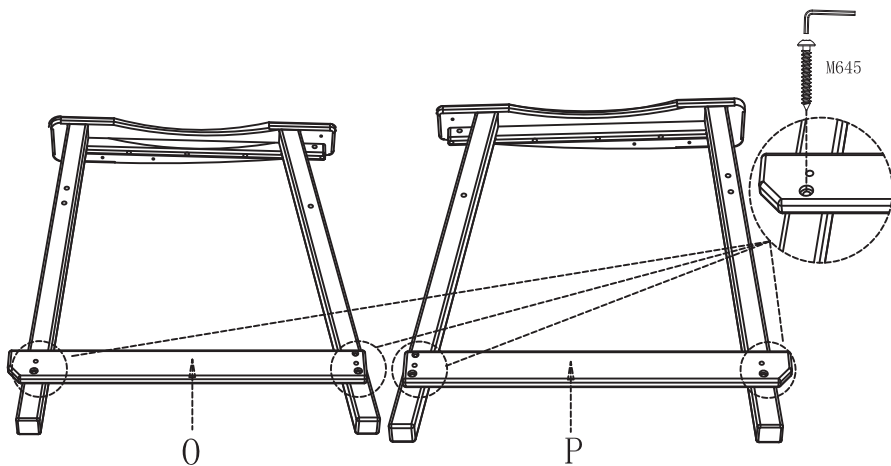

Attach the **(O)** to the Right Armrest Frame and **(P)** to the Left Armrest Frame with Screws M6*45 (M645) by using Allen Wrench .

STEP 8

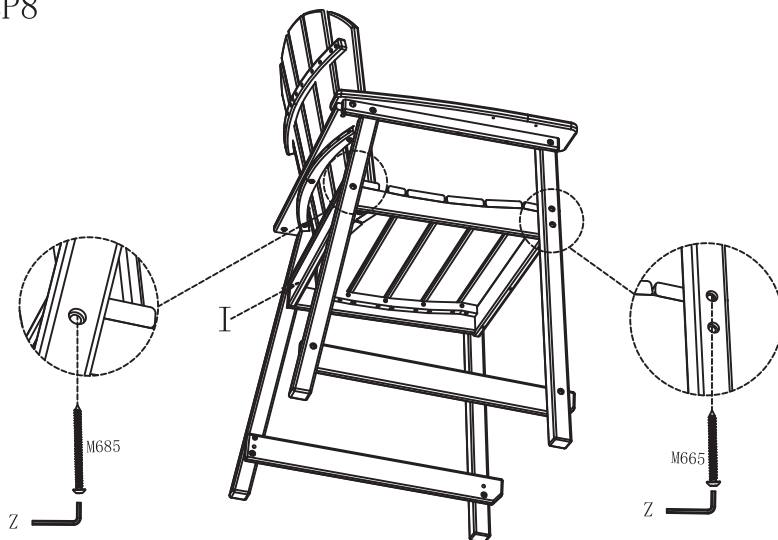

Attach the Right Armrest to the Seat Panel (A) with Screws M6*85 (M685) and Screws M6*65 (M665) by using an Allen Wrench. Please note that need to assemble Part I at the same time.

STEP9

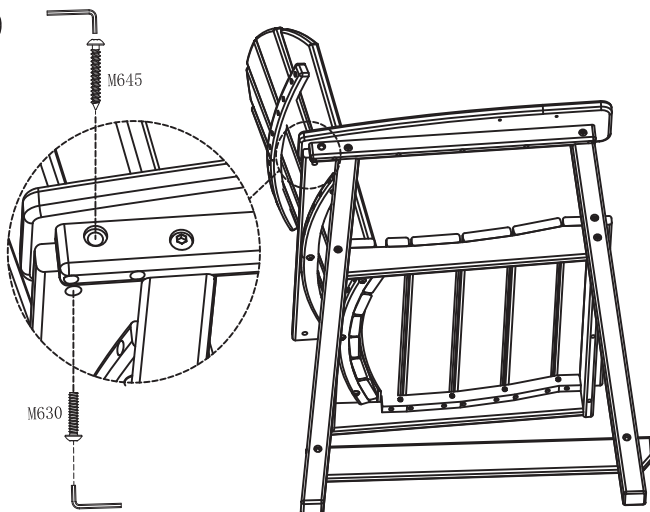

Attach the Right Armrest to the Back Panel Support (K) with Screws M6*45 (M645) and Screws M6*30 (M630) by using Allen Wrench .

STEP10

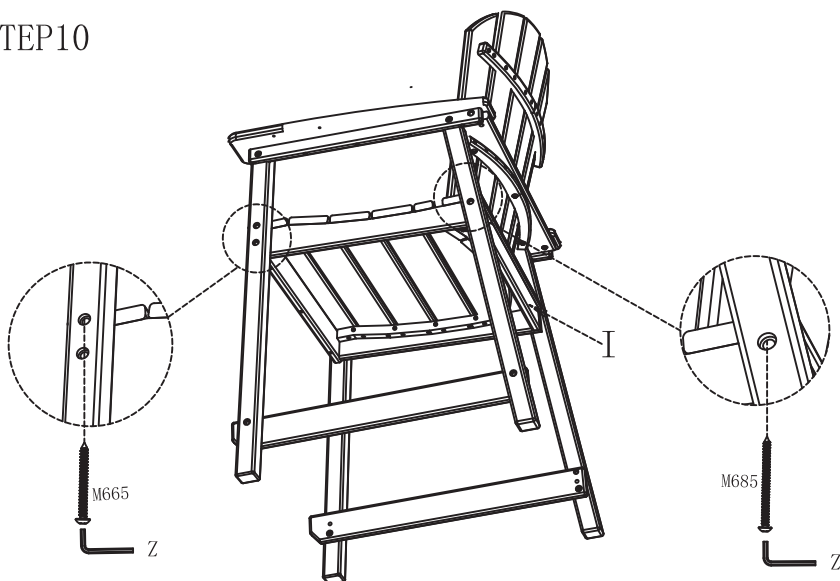

Attach the Left Armrest to the Seat Panel (A) with Screws M6*85 (M685) and Screws M6*65 (M665) by using an Allen Wrench .

STEP11

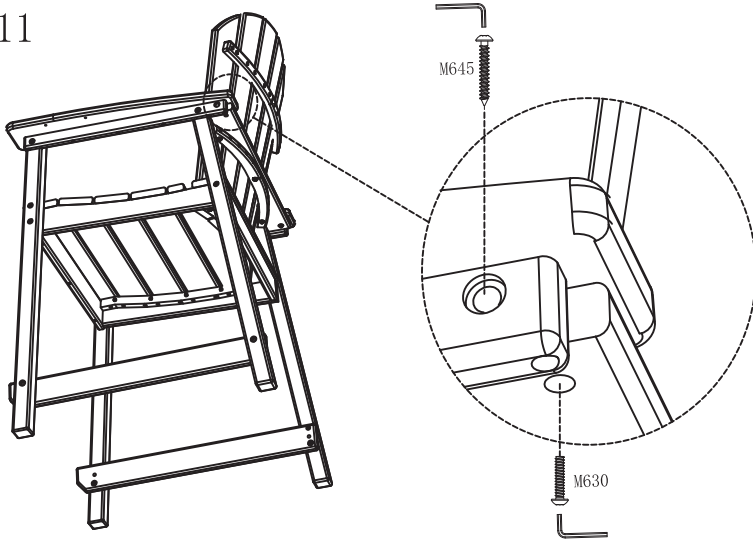

Attach the Left Armrest to the Back Panel Support (**K**) with Screws M6*45 (M645) and Screws M6*30 (M630) by using Allen Wrench .

STEP12

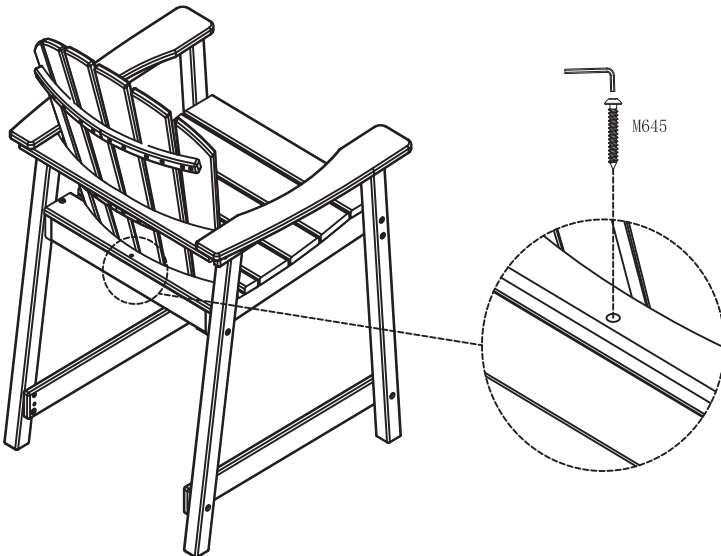

Use the Allen wrench and Screw M6*45 (M645) to fix the Back Panel Support (**J**) and Seat Panel Support (**I**).

STEP13

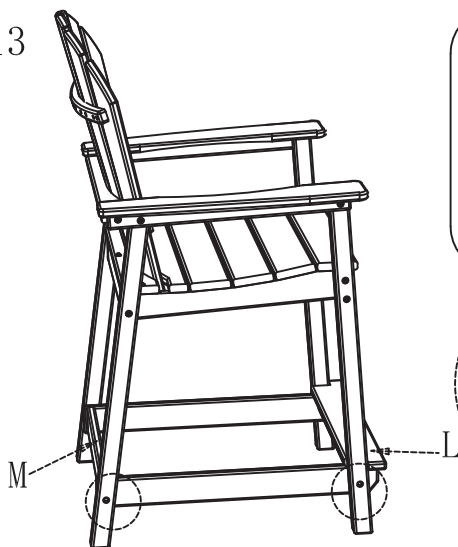

Helpful Tip

The "M" are designed to facilitate alignment during assembly. It will not affect the assembly or stability of the chair even if they are broken. Take your time to put it all together, and feel free to contact us support@a-ecoliving.com if you encounter any issues. Thank you for your support and patience!

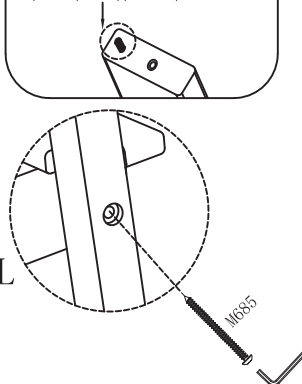

STEP14

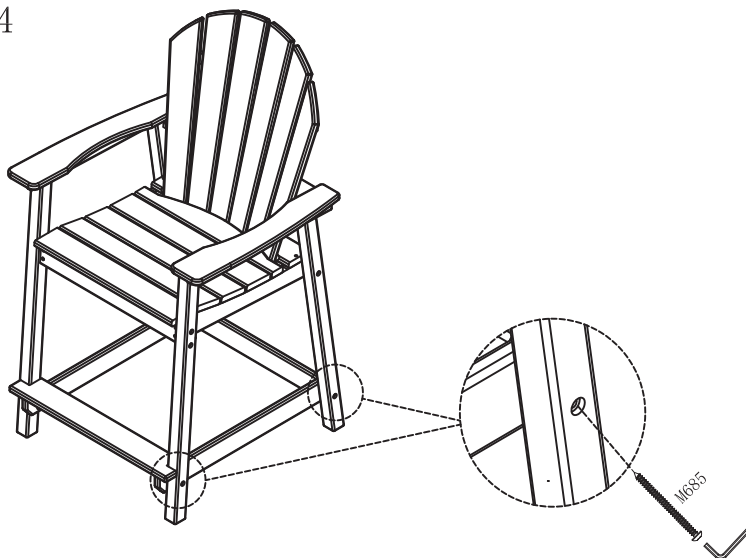

Attach the Front Connecting Rod (**L**) and Back Connecting Rod (**M**) to the Left and Right Armrests with Screws M6*85 (M685) by using Allen Wrench.



Customer Service: This manual may not include every detail of the product and considered steps. Please feel free to reach out to us via our official email when further information and help are needed. Our experienced customer service support reply to you within 24 hours.



The material can be cleaned by wiping it with water and a cloth for convenient maintenance.