

ASSEMBLY INSTRUCTION

ASSEMBLY INSTRUCTION

ASSEMBLY TIPS:

1. Remove hardware from box and sort by size.
2. Please check to see that all hardware and parts are present prior to start of assembly.
3. Please follow attached instructions in the same sequence as numbered to assure fast & easy assembly.



Warning!!



1. Don't attempt to repair or modify parts that are broken or defective. Please contact the store immediately.
2. This product is for home use only and not intended for commercial establishment.



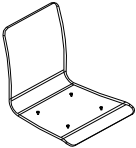
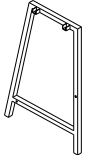
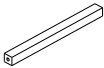
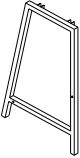
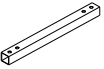

ASSEMBLY TIME PER UNIT: 20 MINUTES

PARTS IDENTIFICATION

<p>A</p> <p>SEAT AND BACK  2PCS</p> <p>C</p> <p>RIGHT FRAME  2PCS</p> <p>E</p> <p>BOTTOM CROSSBAR  4PCS</p>	<p>B</p> <p>LEFT FRAME  2PCS</p> <p>D</p> <p>TOP CROSSBAR  4PCS</p>
---	--

HARDWARE PACKAGE

Z	DESCRIPTION	FIGURE	Q'TY
1	SHORT BOLT		8PCS
2	LONG BOLT		8PCS
3	WASHER		16PCS

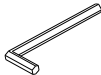
4	PLASTIC WASHER		8PCS
5	SPRING WASHER		16PCS
6	NUT		8PCS
7	CAP		8PCS
8	HEX CAP HEAD BOLT		8PCS
9	ALLEN WRENCH		1PC

NOTE: PARTS LISTED ABOVE ARE FOR TWO CHAIRS

STEP 1

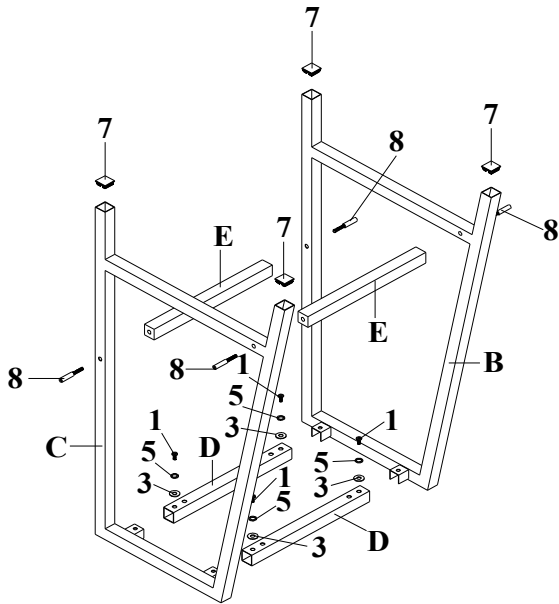

STEP 2

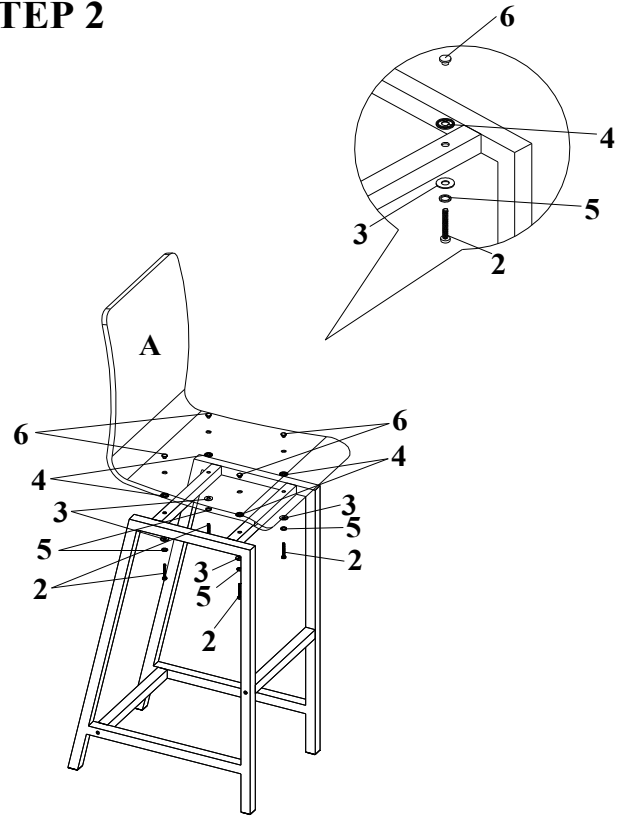

FINISH

