

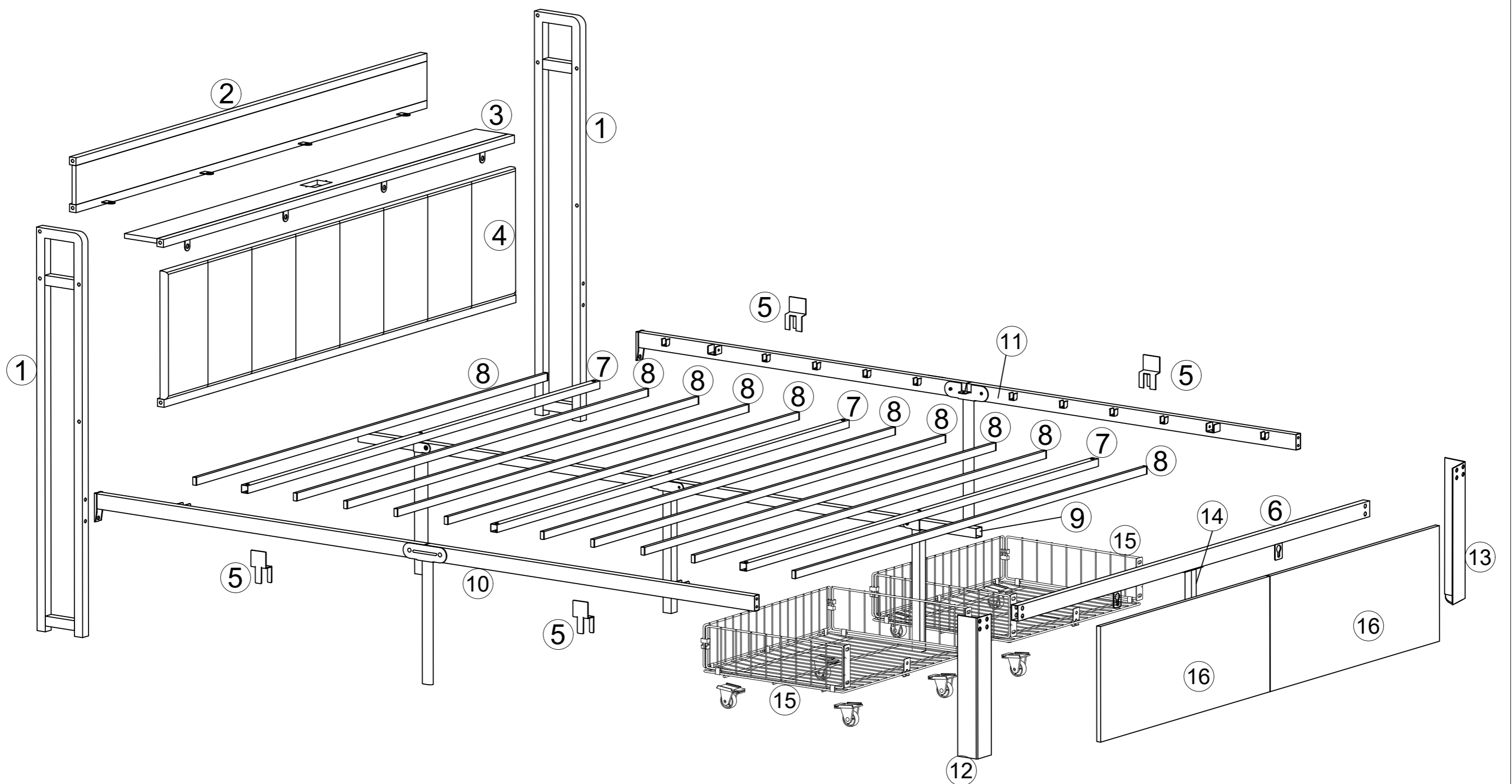

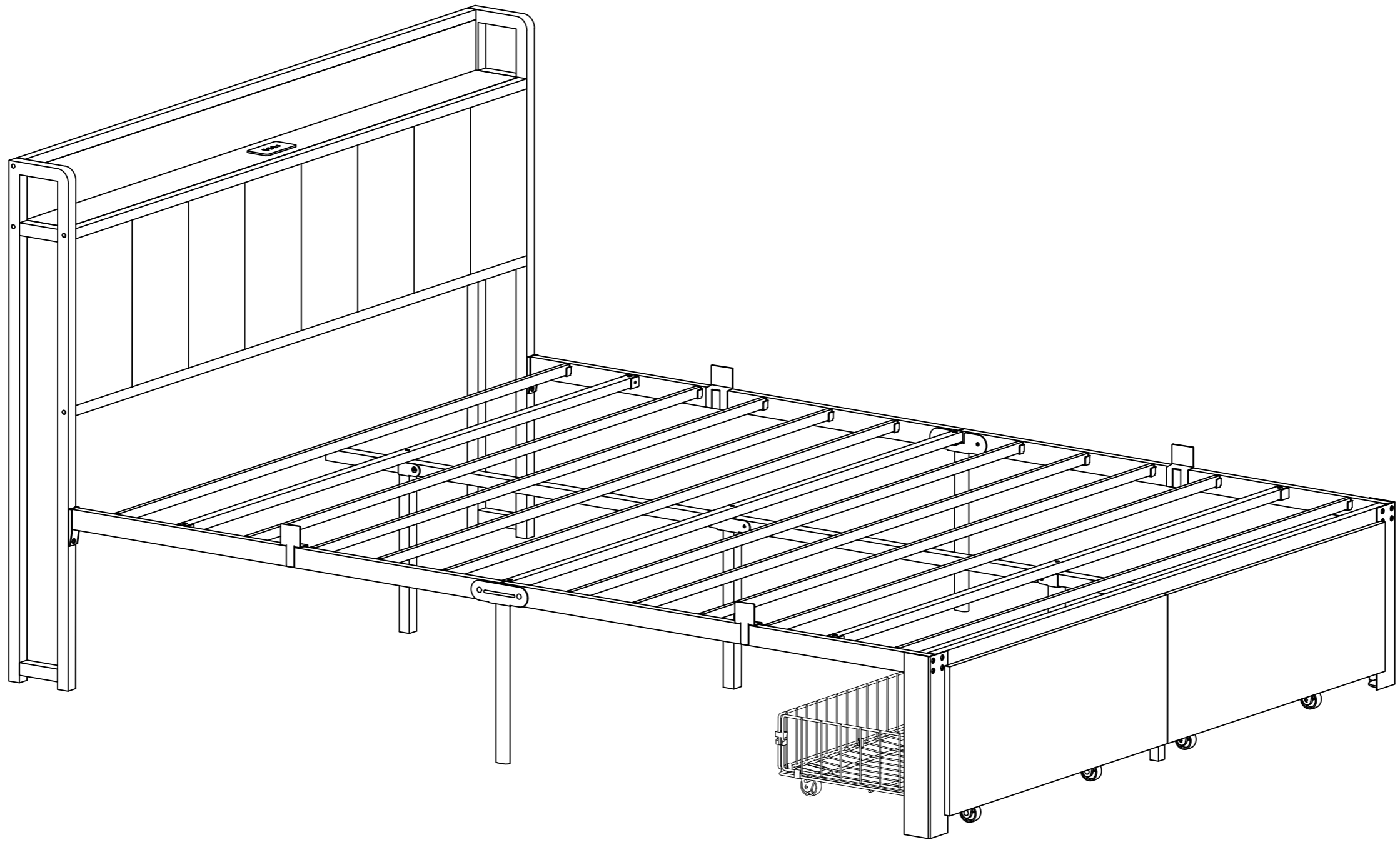

Installation Manual

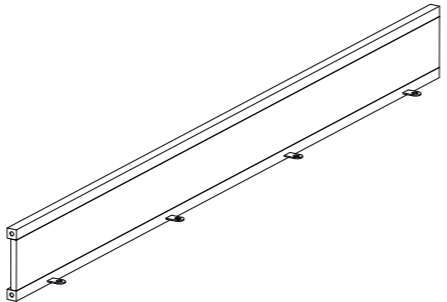
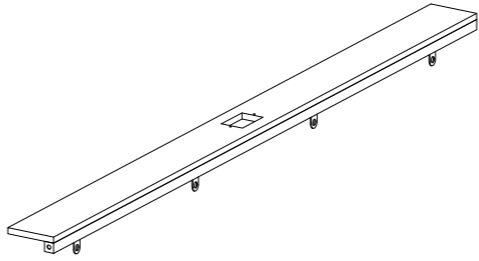
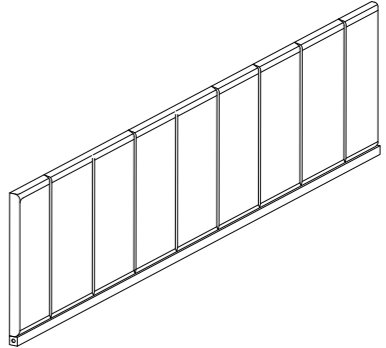
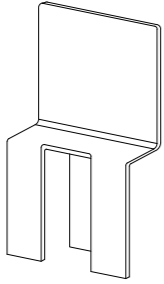
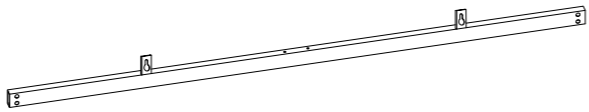
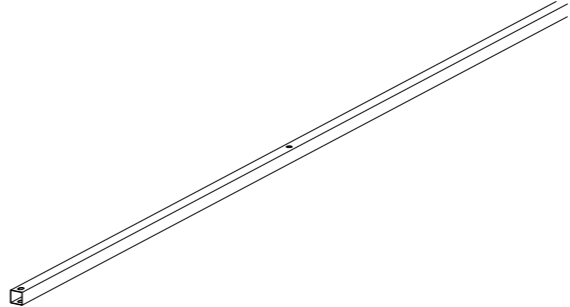
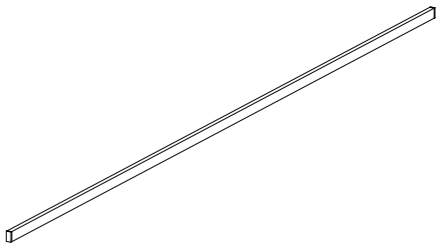
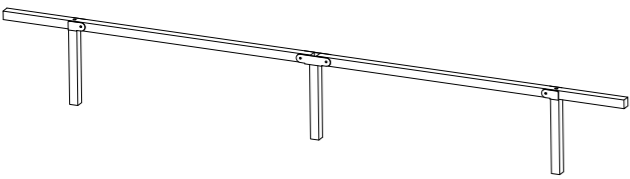
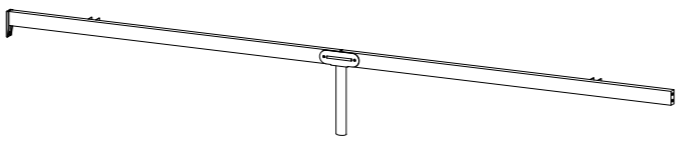
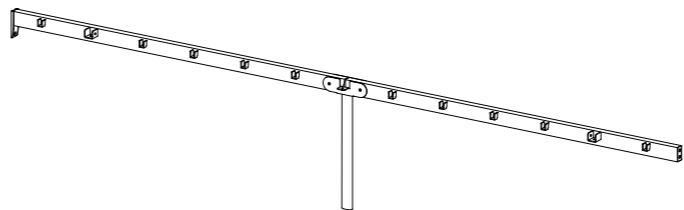
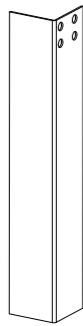

 ① × 2pcs	 ② × 1pc	 ③ × 1pc	 ④ × 1pc	
 ⑤ × 4pcs	 ⑥ × 1pc	 ⑦ × 3pcs	 ⑧ × 10pcs	
 ⑨ × 1pc	 ⑩ × 1pc	 ⑪ × 1pc	 ⑫ × 1pc	
 ⑬ × 1pc	 ⑭ × 1pc	 ⑮ × 2pcs	 ⑯ × 2pcs	
 M8×40mm A × 4pcs	 M8×35mm B × 8pcs	 M6×55mm C × 3pcs	 M6×45mm D × 8pcs	 M6×30mm E × 6pcs
 M6×12mm F × 6pcs	 M6×10mm G × 14pcs	 M8 H × 4pcs	 M8×24mm I × 2pcs	 Ø3.5×12mm J × 2pcs
 K × 2pcs	 L × 4pcs	 M × 8pcs	 N × 1pc	 O × 1pc
 P-1 4MM P × 1pc	 Q × 1pc	Note: To ensure customers can complete the assembly smoothly, an extra screw is provided for each screw model.		

1

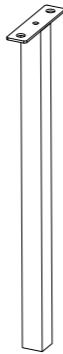
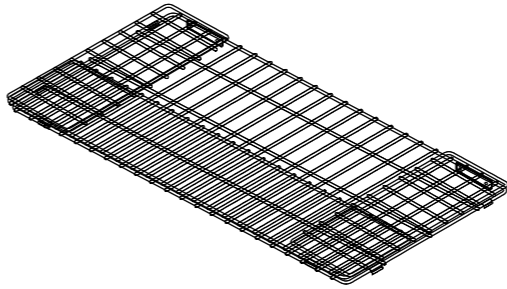
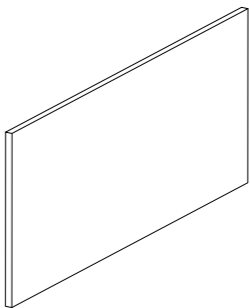
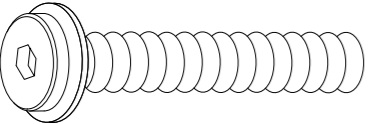
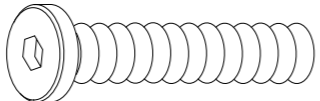
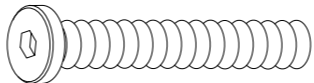
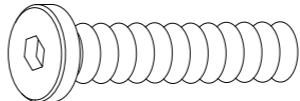
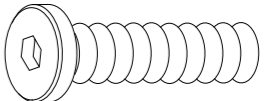
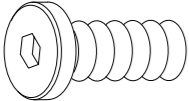
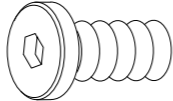
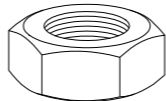
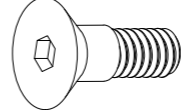
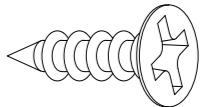
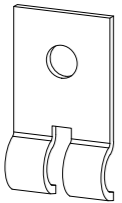
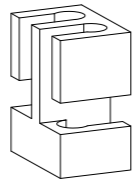
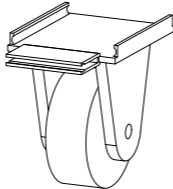
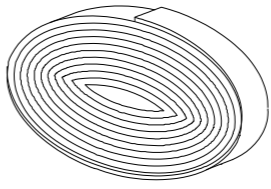
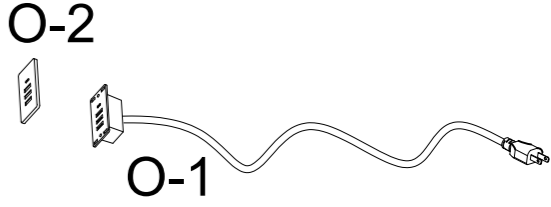
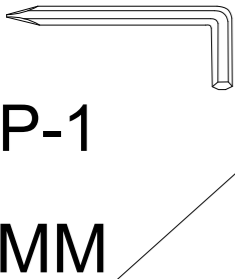
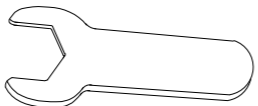
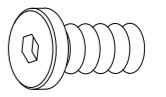
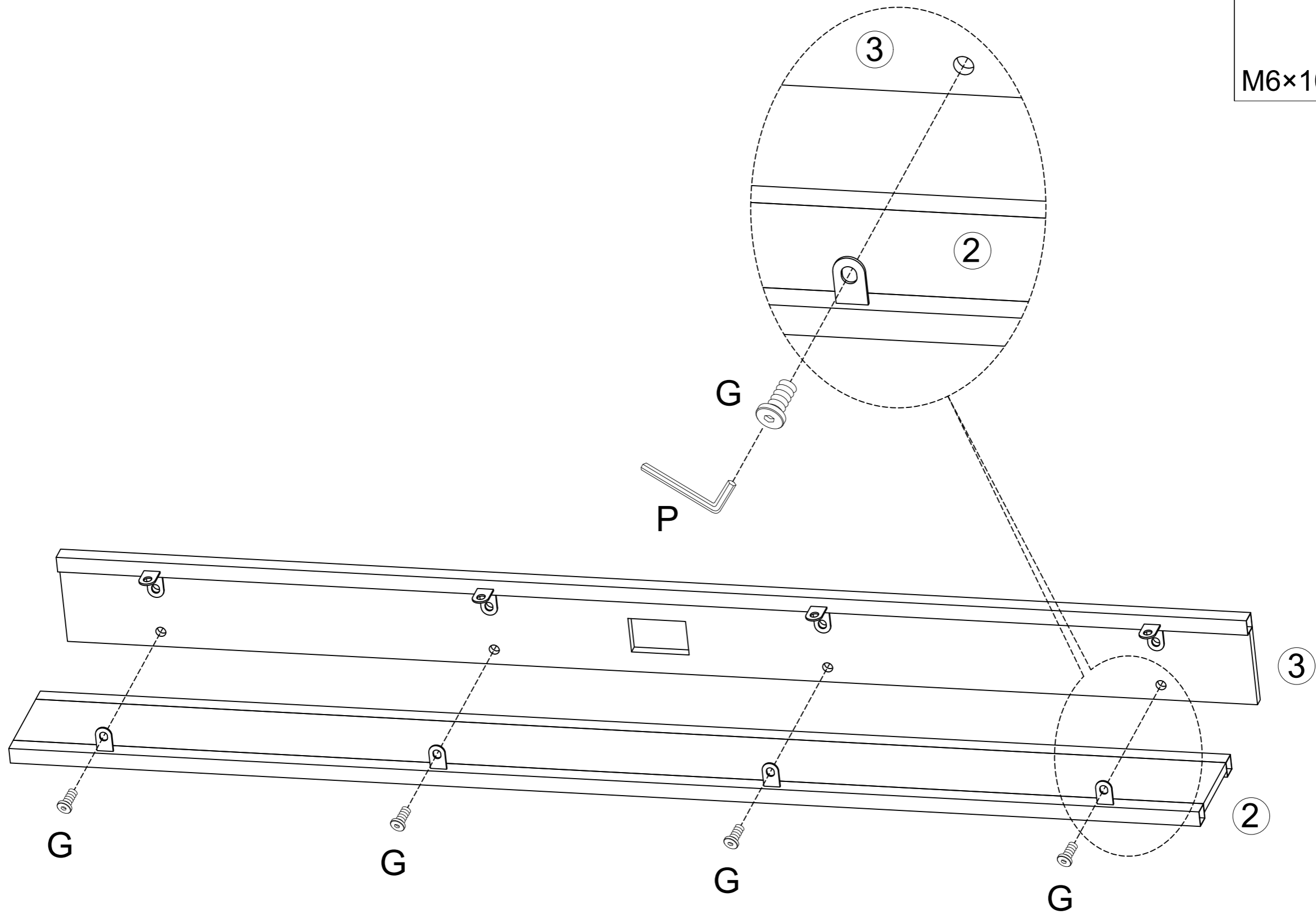
G**M6×10mm** **×4**

2

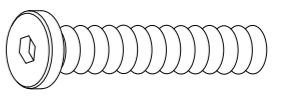
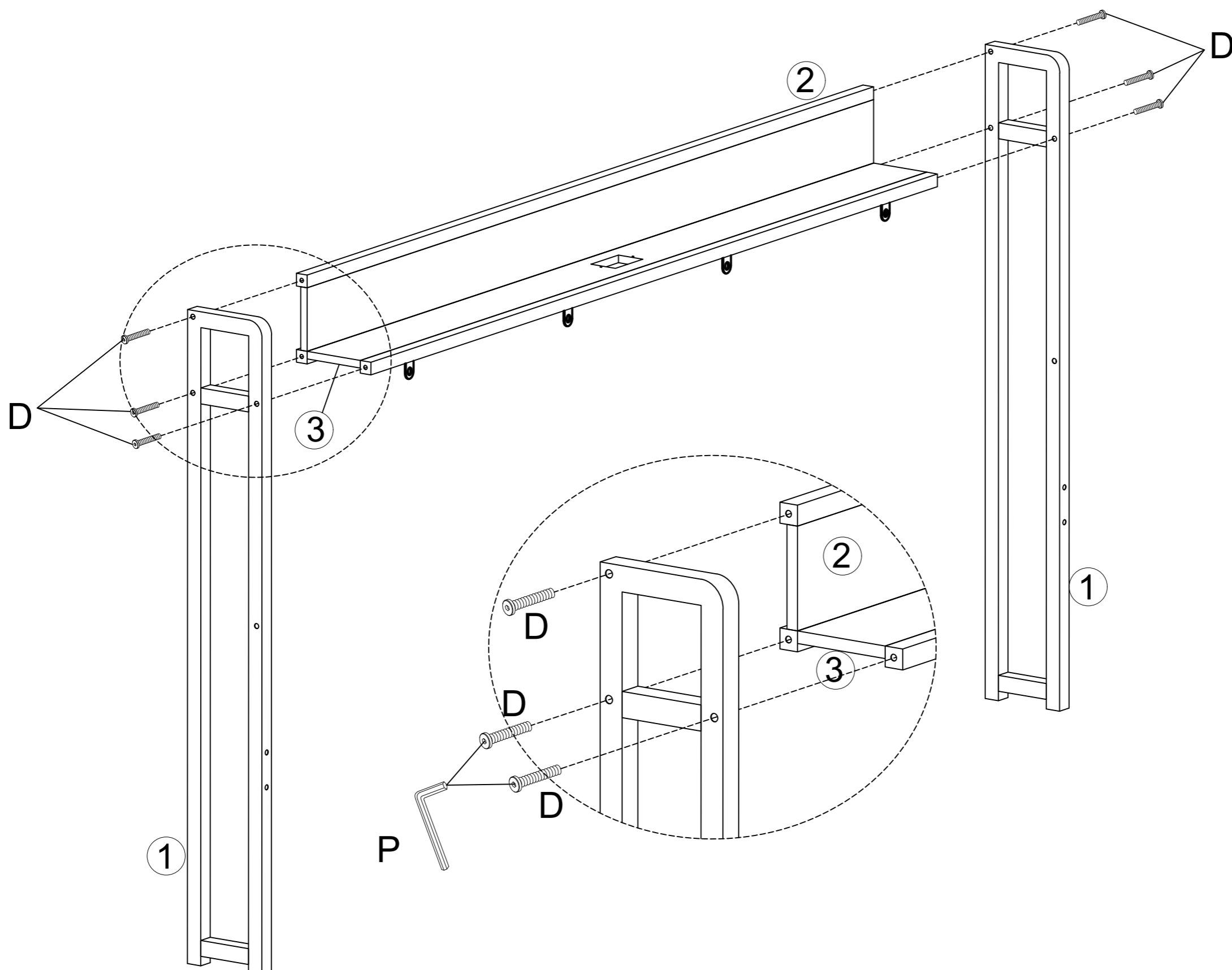
D**M6×45mm** **×6**

3

D

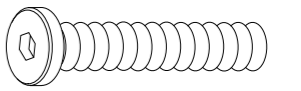

M6×45mm ×2

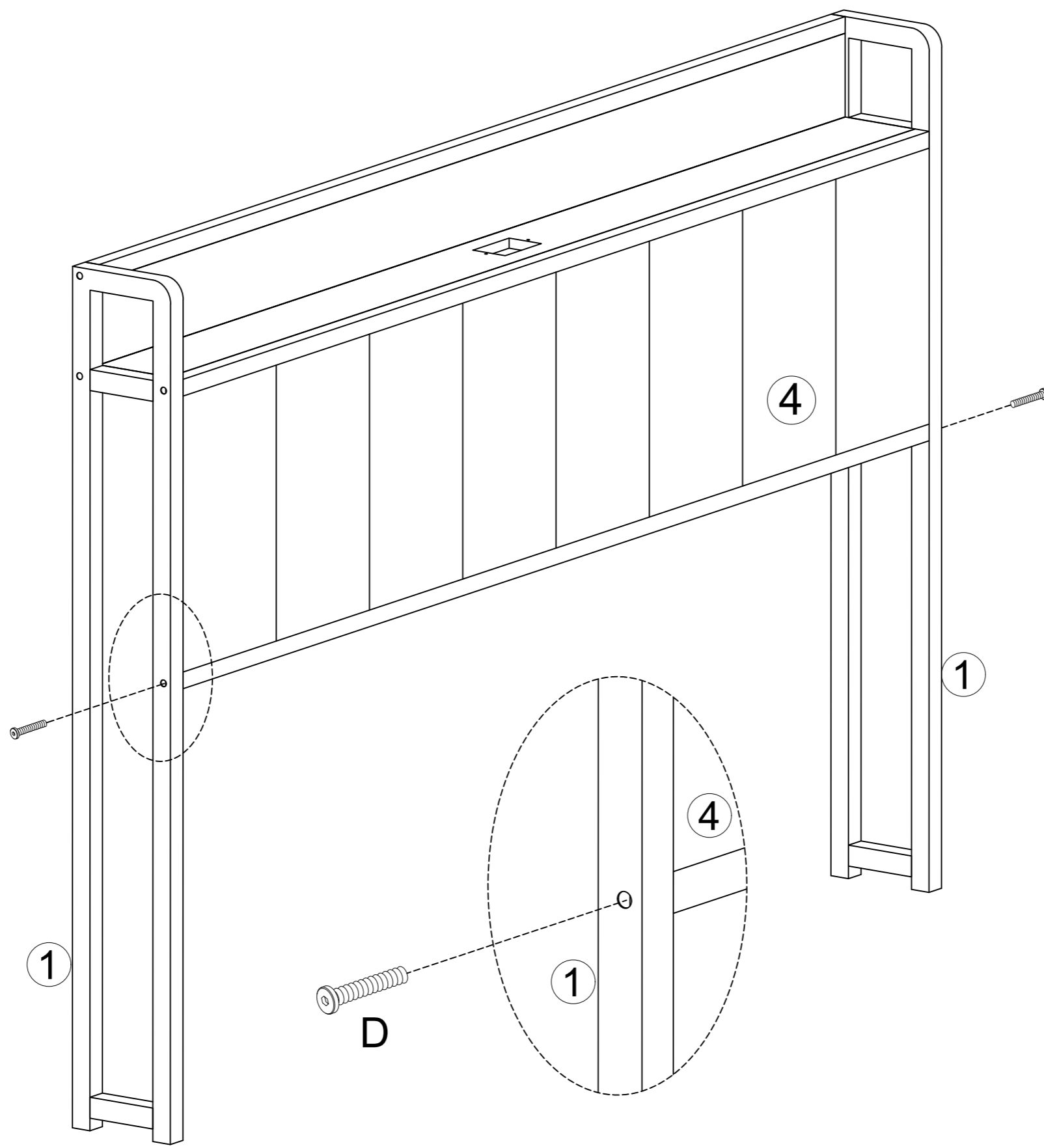

4

F

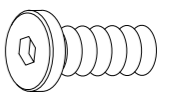

M6×12mm ×4

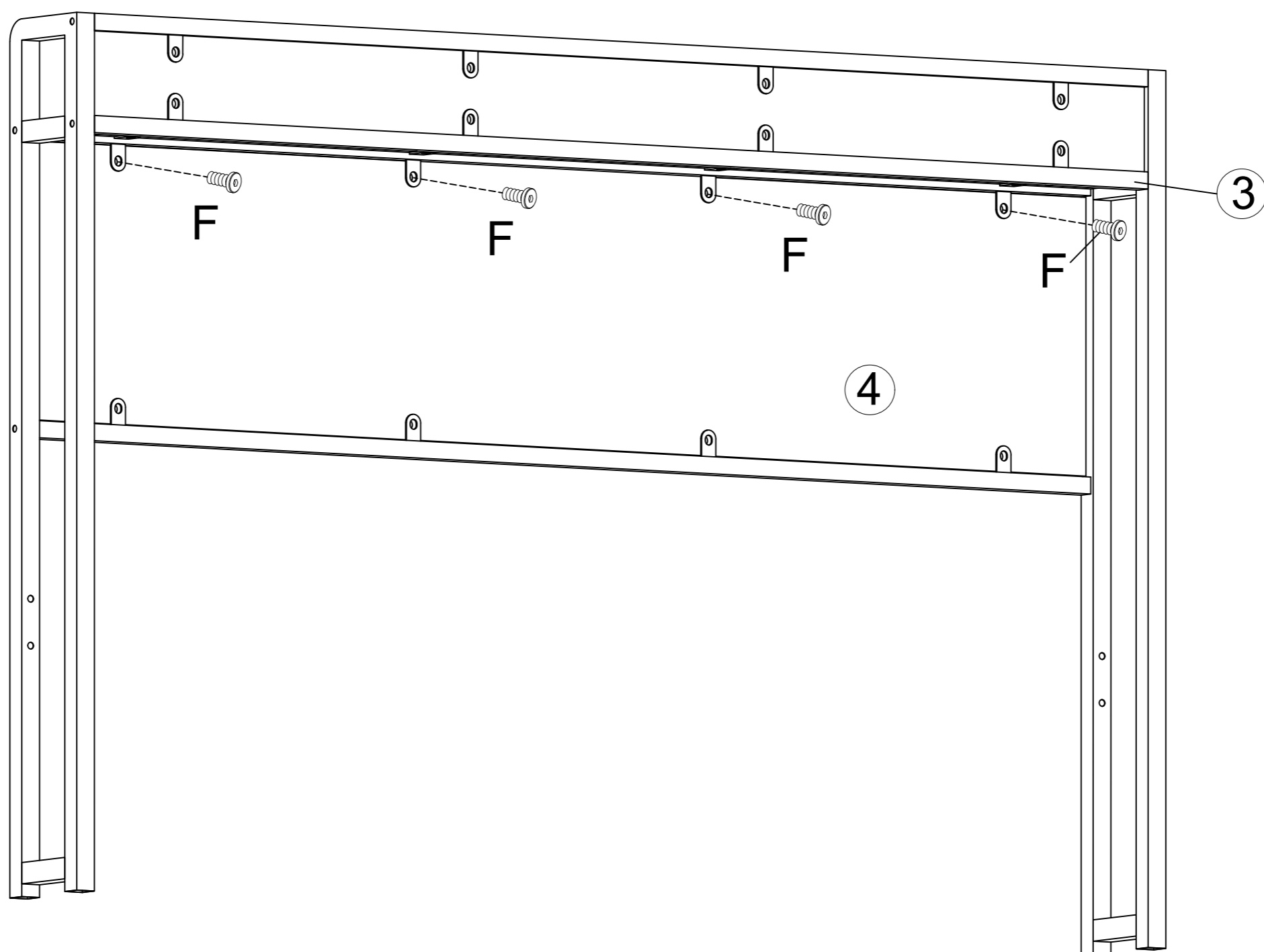

5

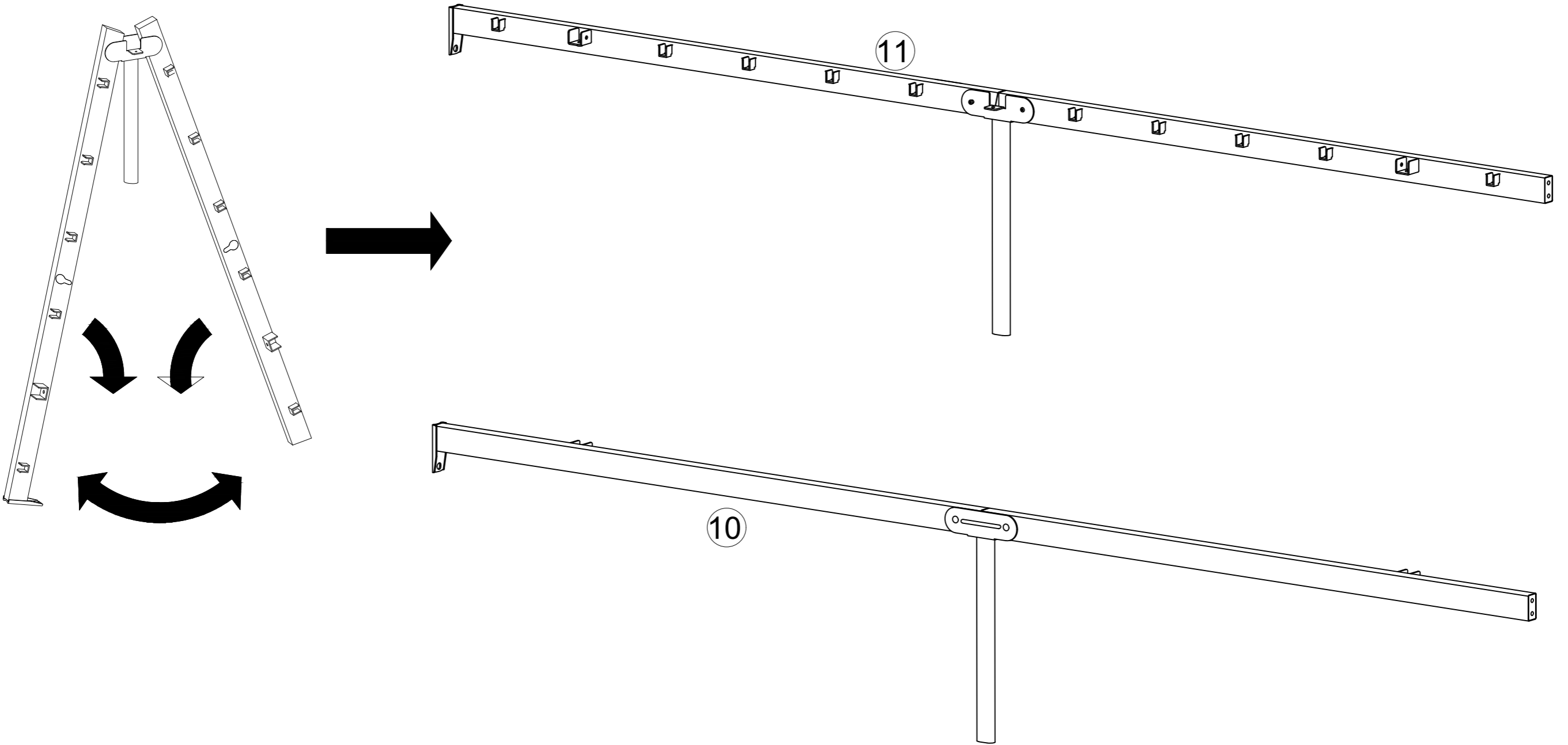

6

A

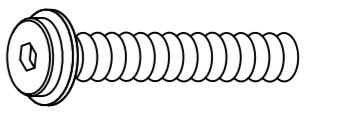

M8×40mm ×4

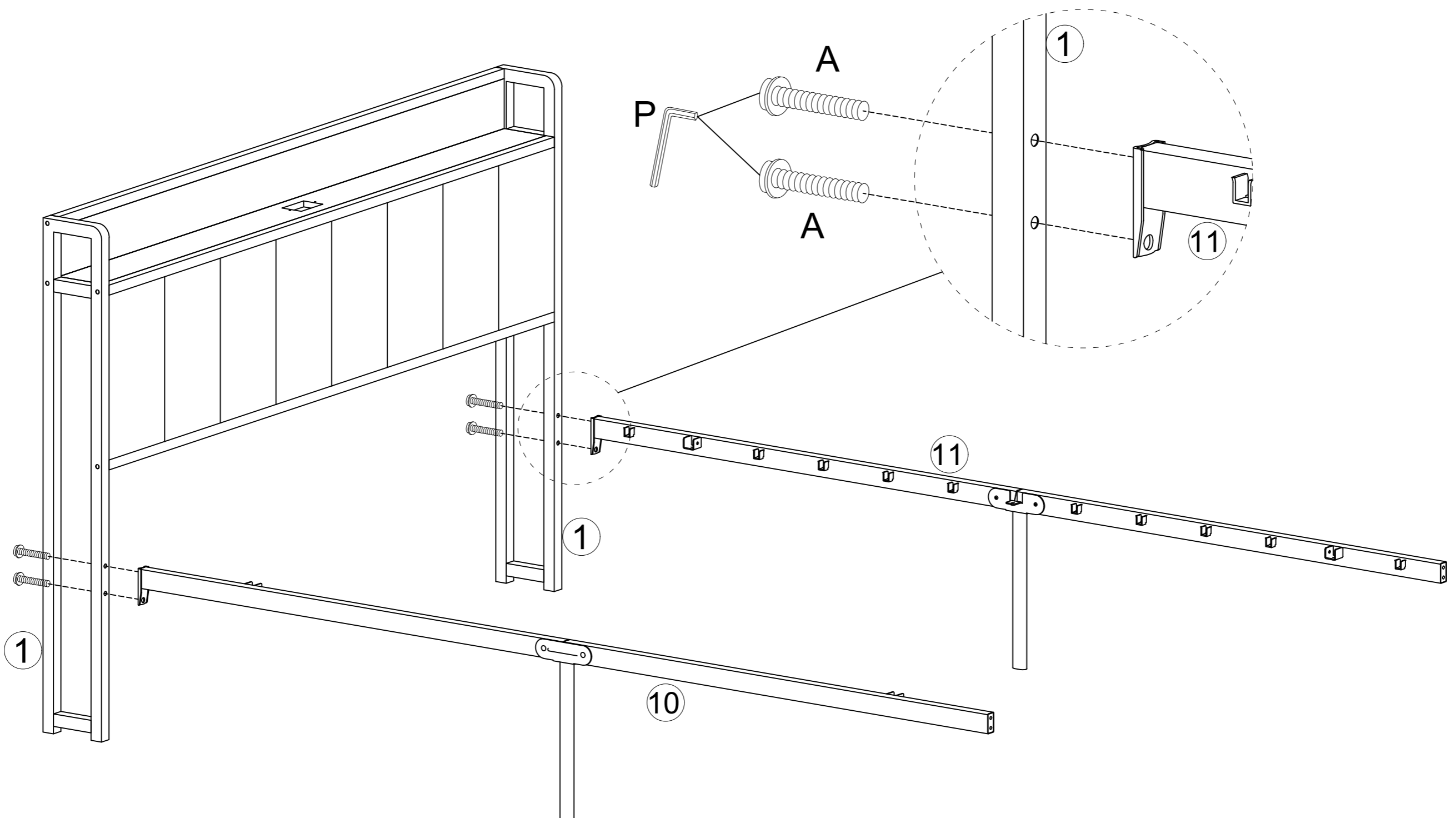

7

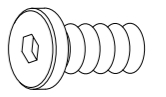
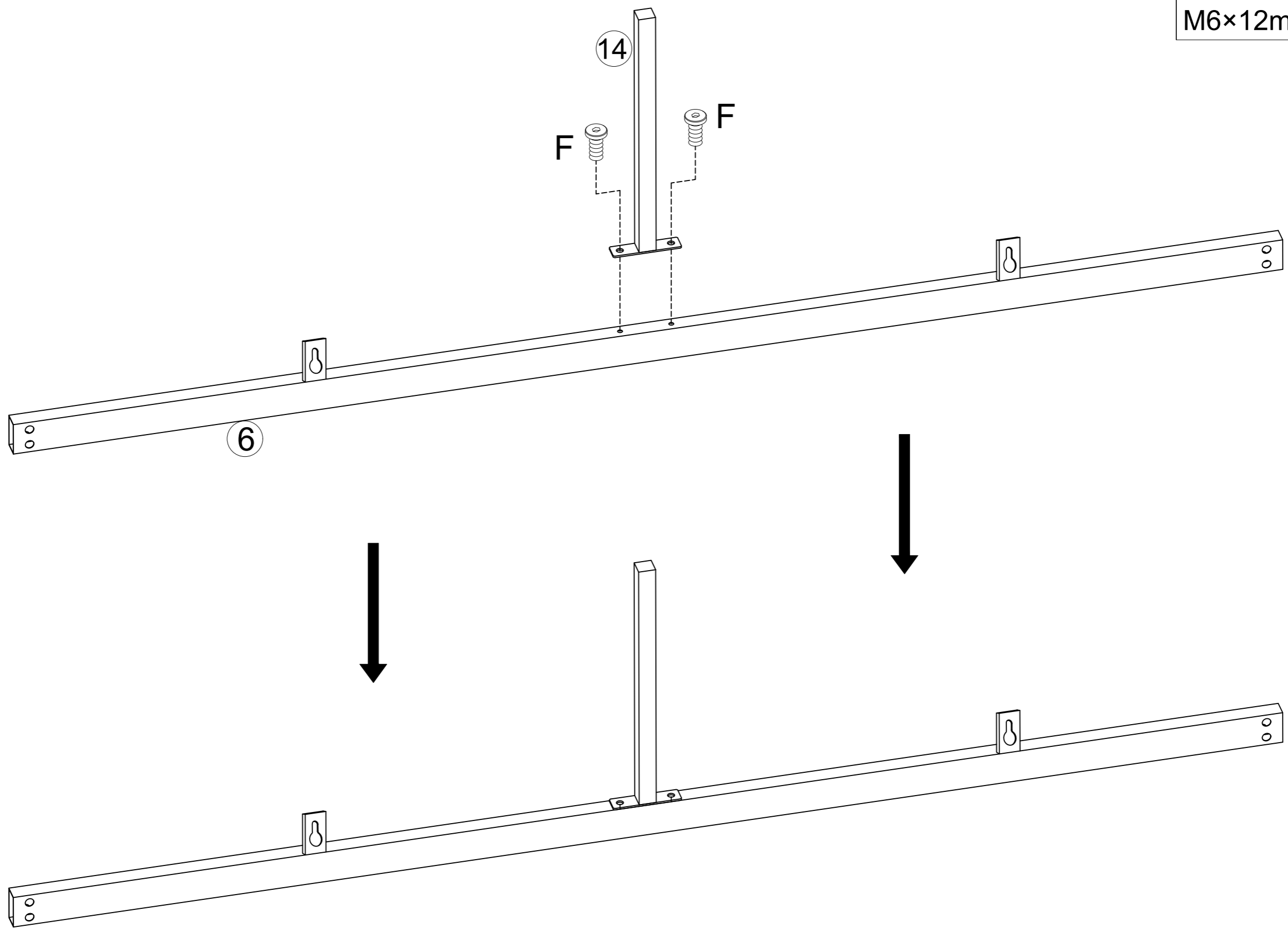
F**M6×12mm** **×2**

8

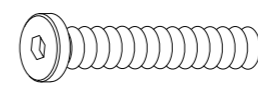
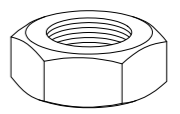
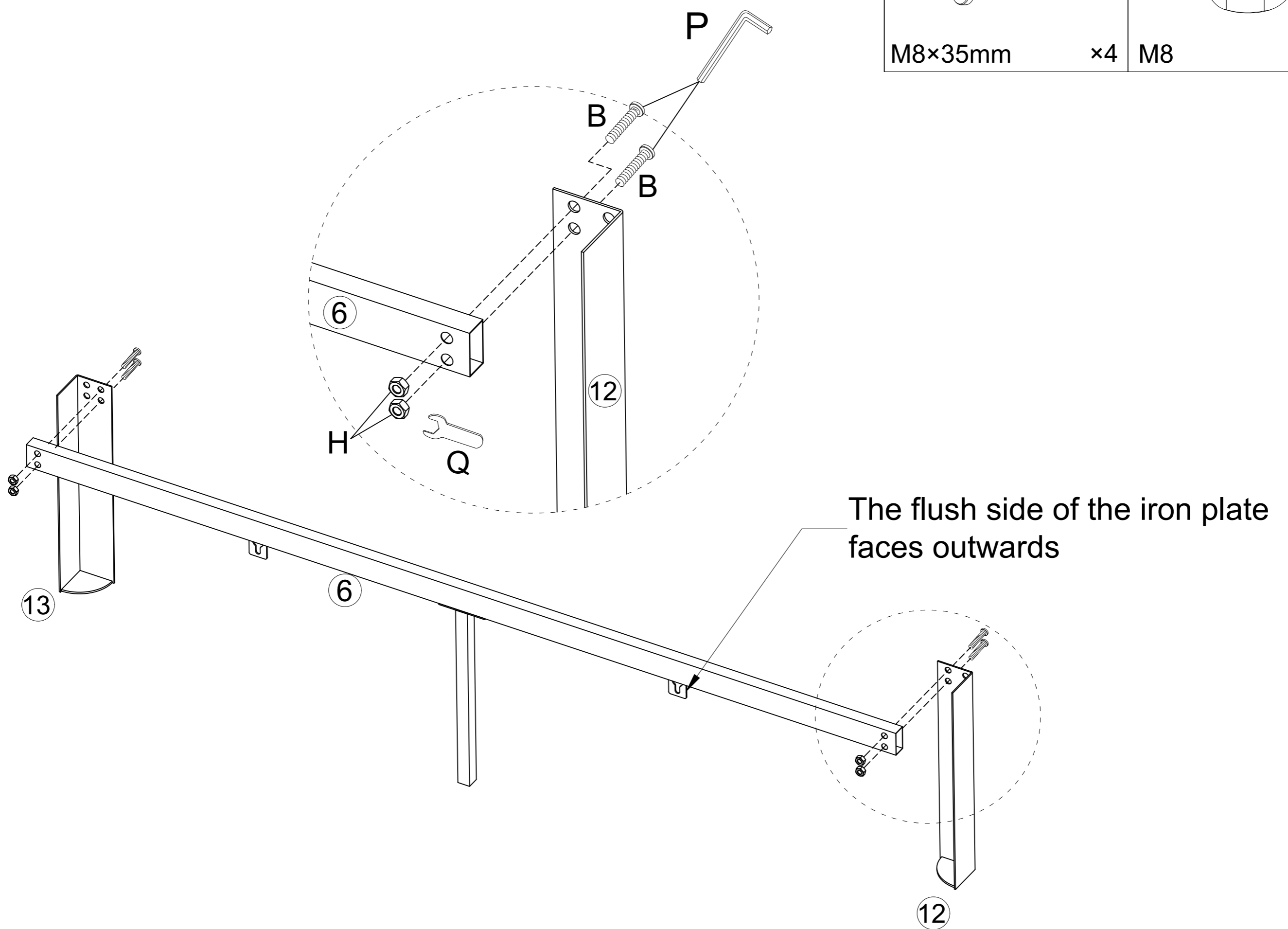
B**M8×35mm** **×4****H****M8** **×4**

9

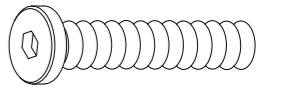
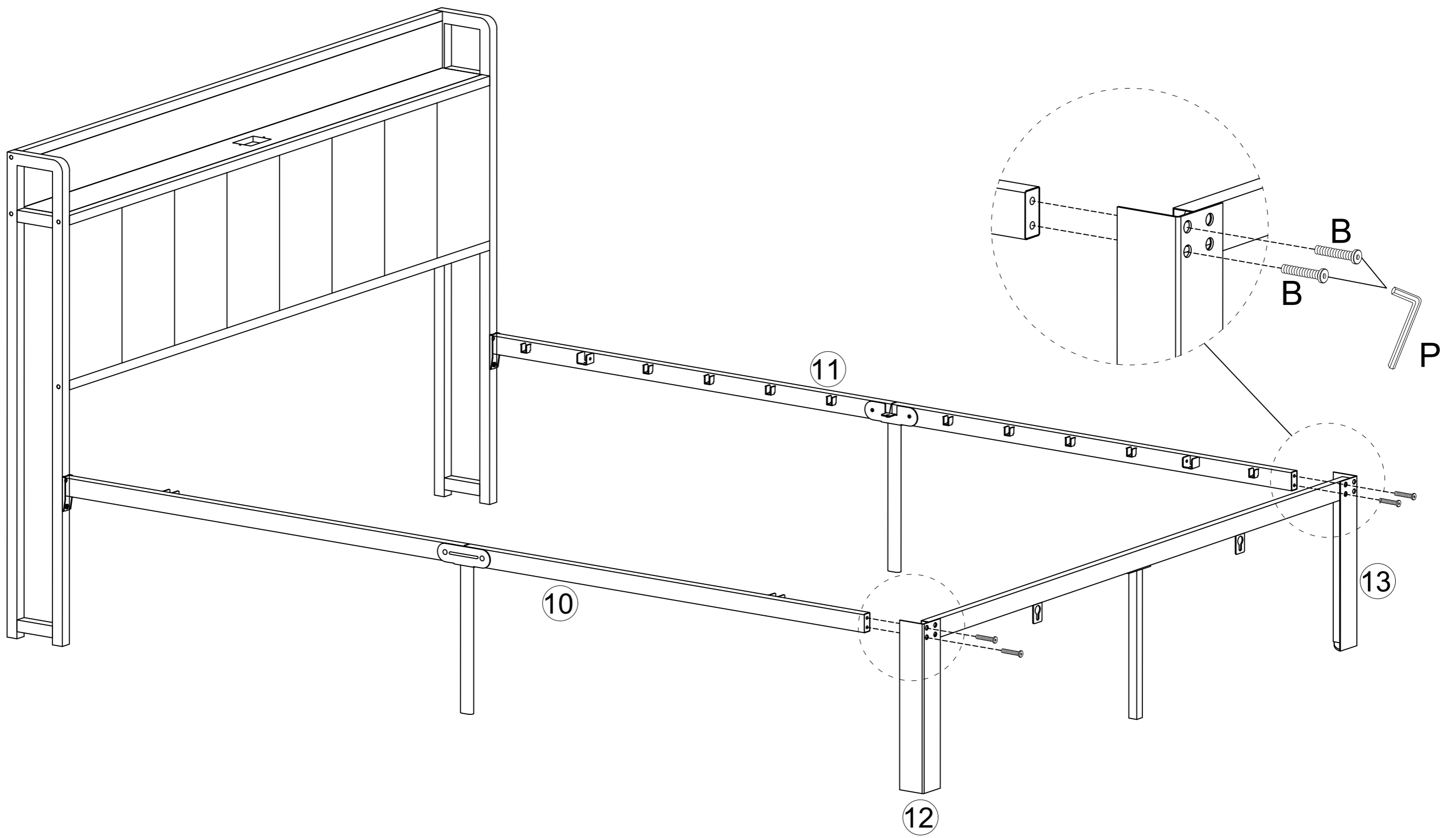
B**M8×35mm** **×4**

10

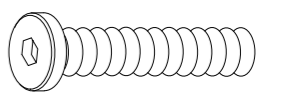
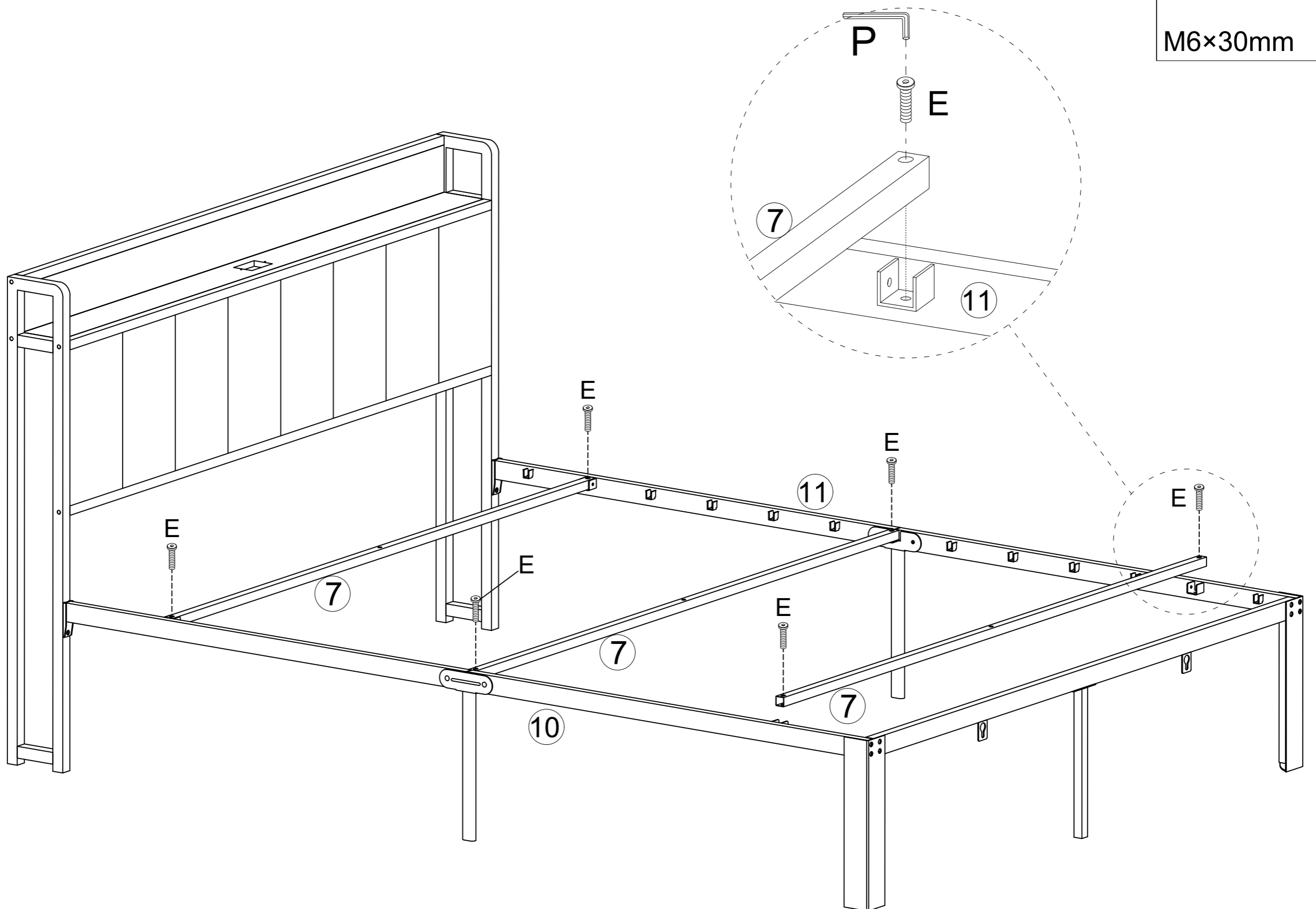
E**M6×30mm** **×6**

11

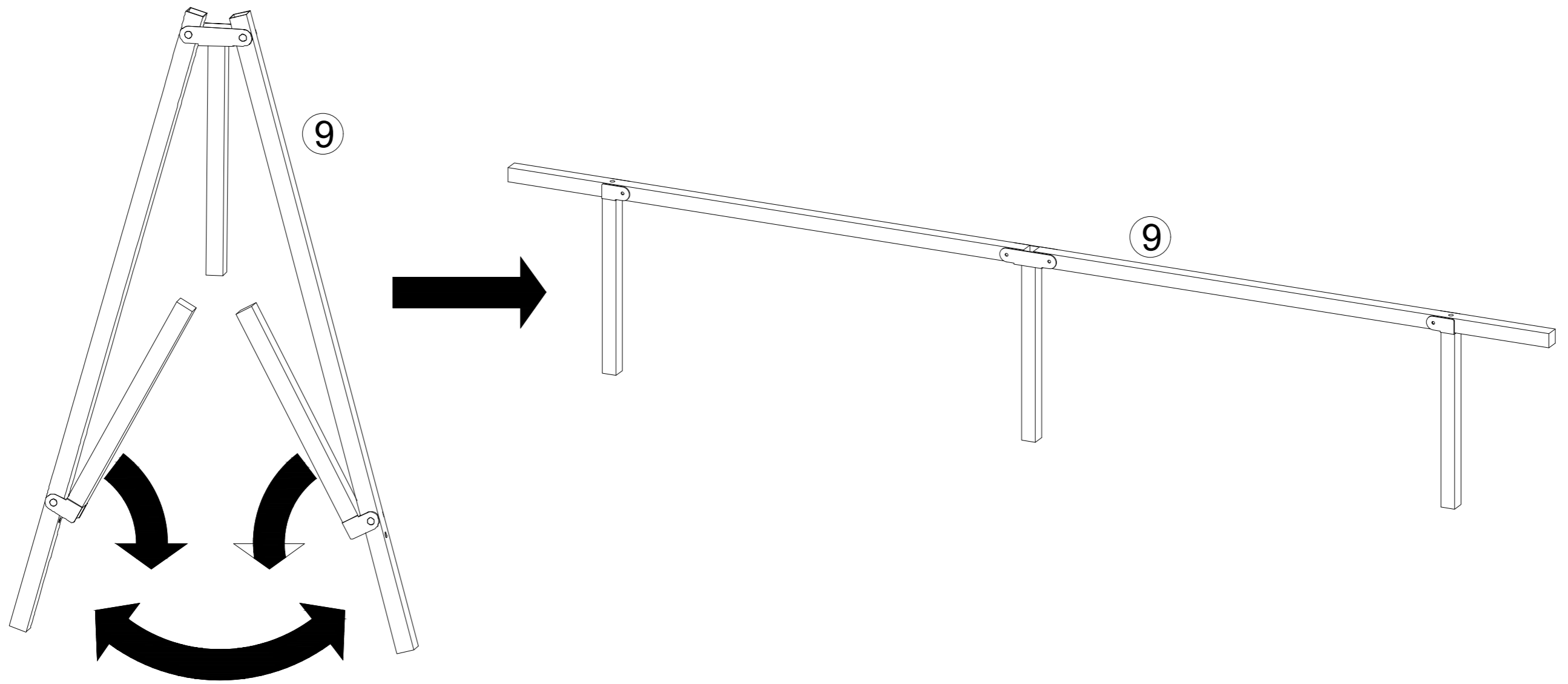

12

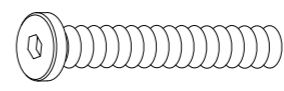
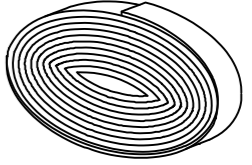
C  M6x55mm x3	N  x1
--	---

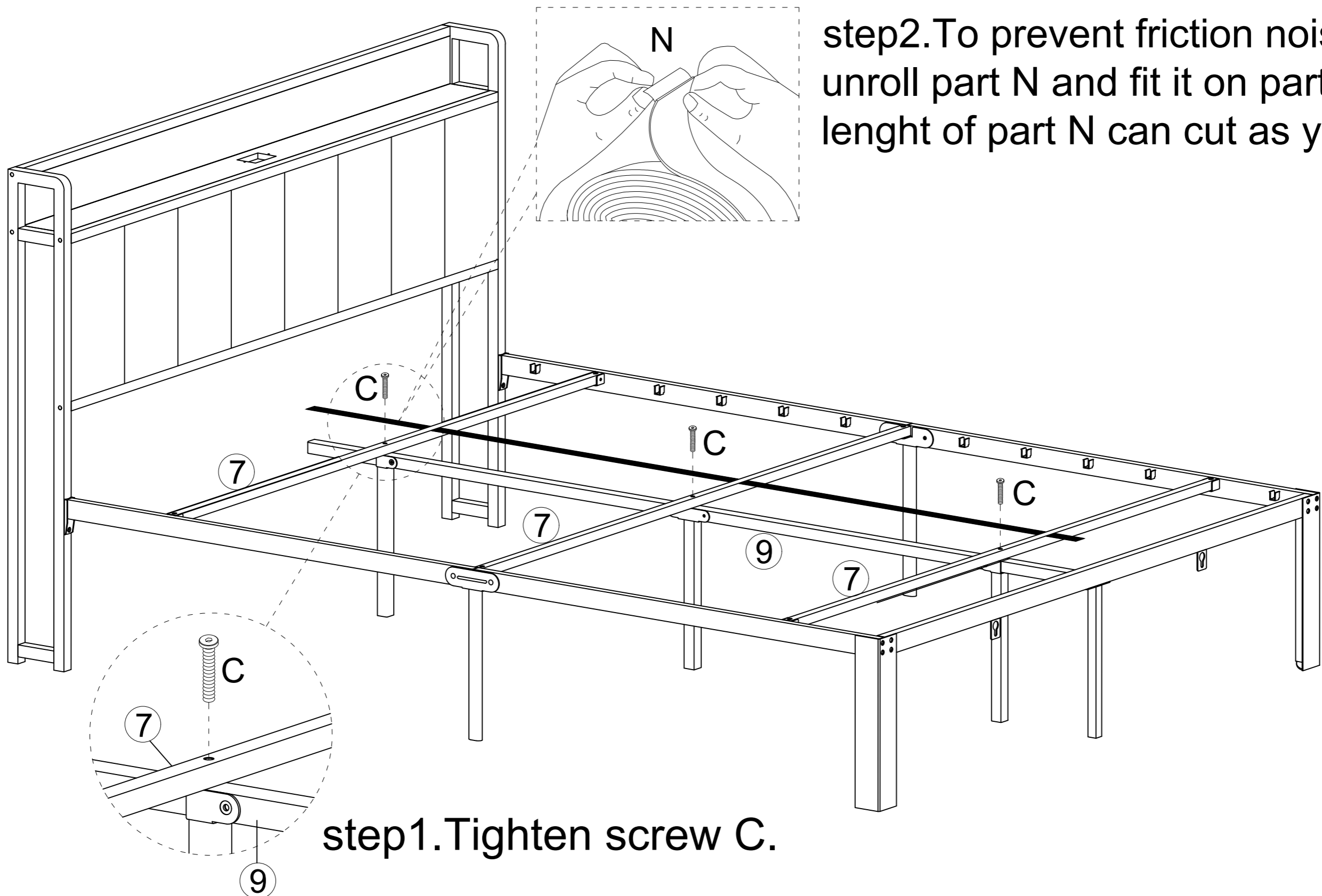

step 1. Tighten screw C.

step 2. To prevent friction noise, unroll part N and fit it on part 9, the length of part N can cut as you will.

13

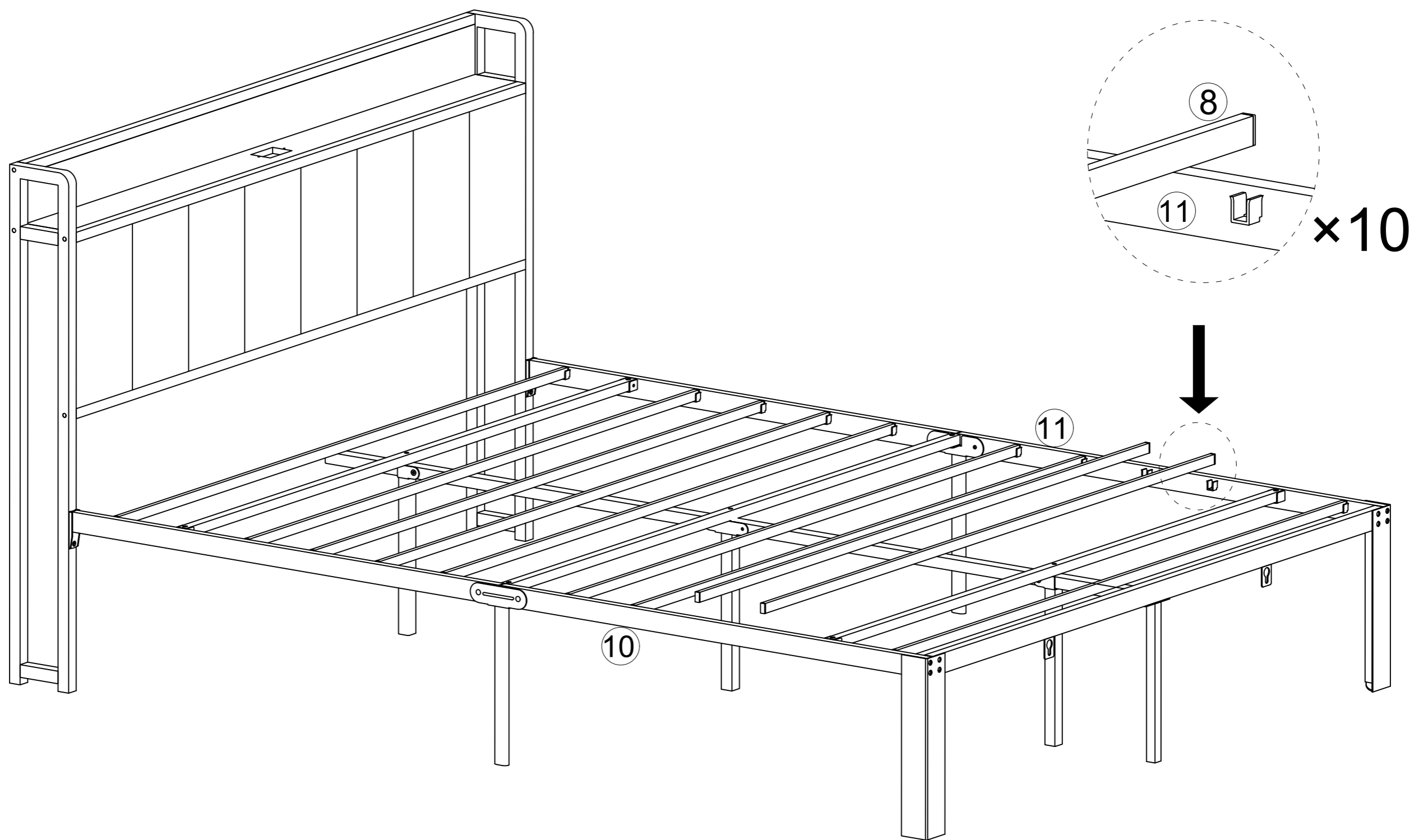

14

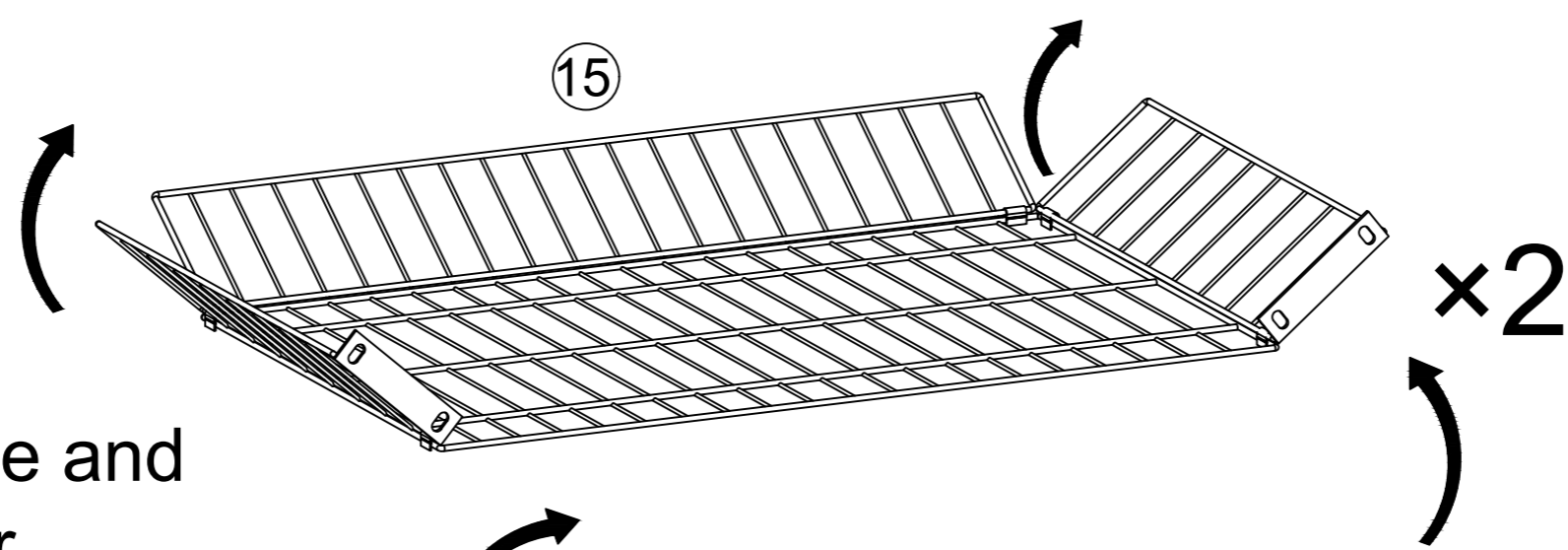
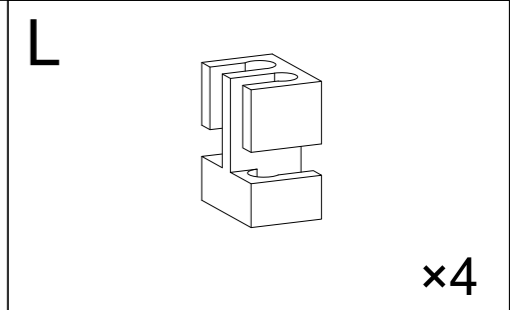

Disconnect it a little and clamp the fastener

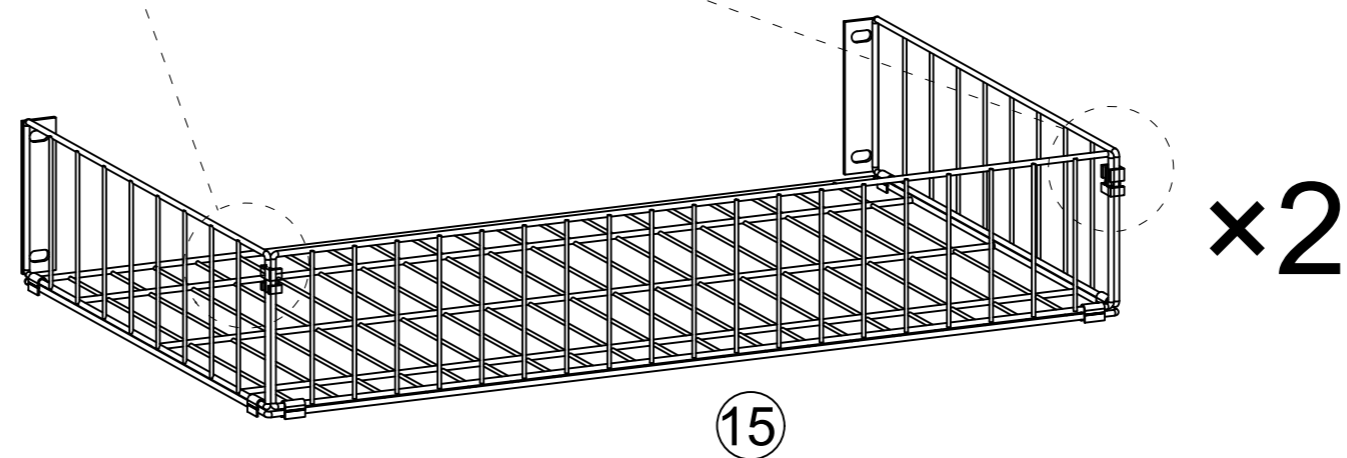
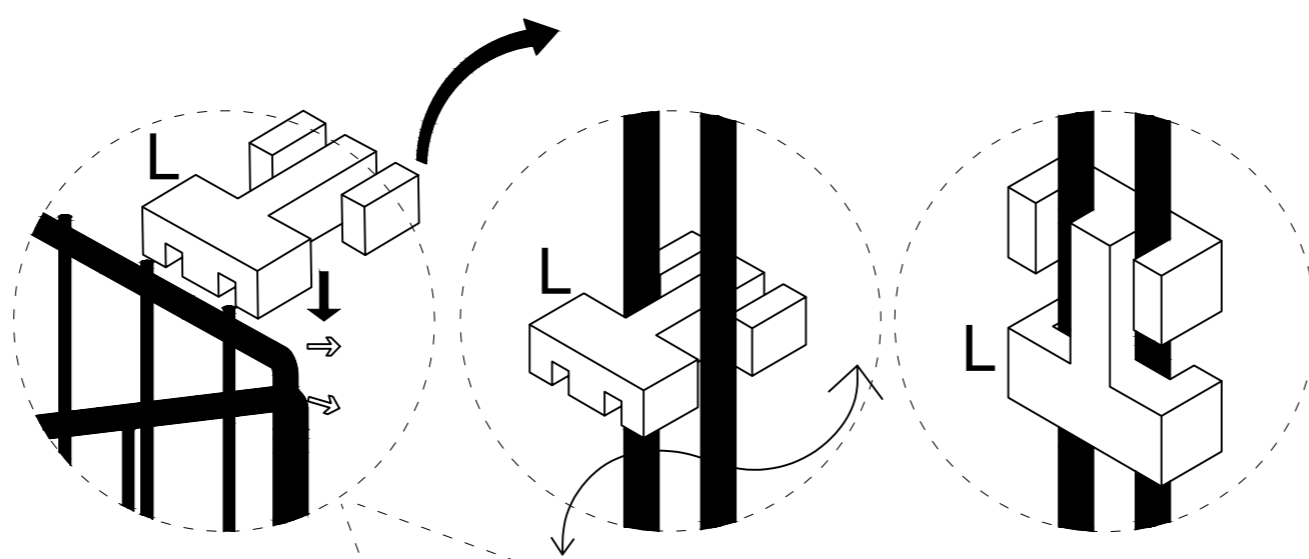

15

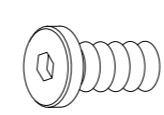
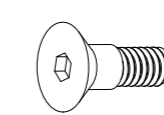
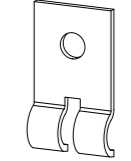
G  M6×10mm	I  M8×24mm	K  ×2
×10	×2	×2

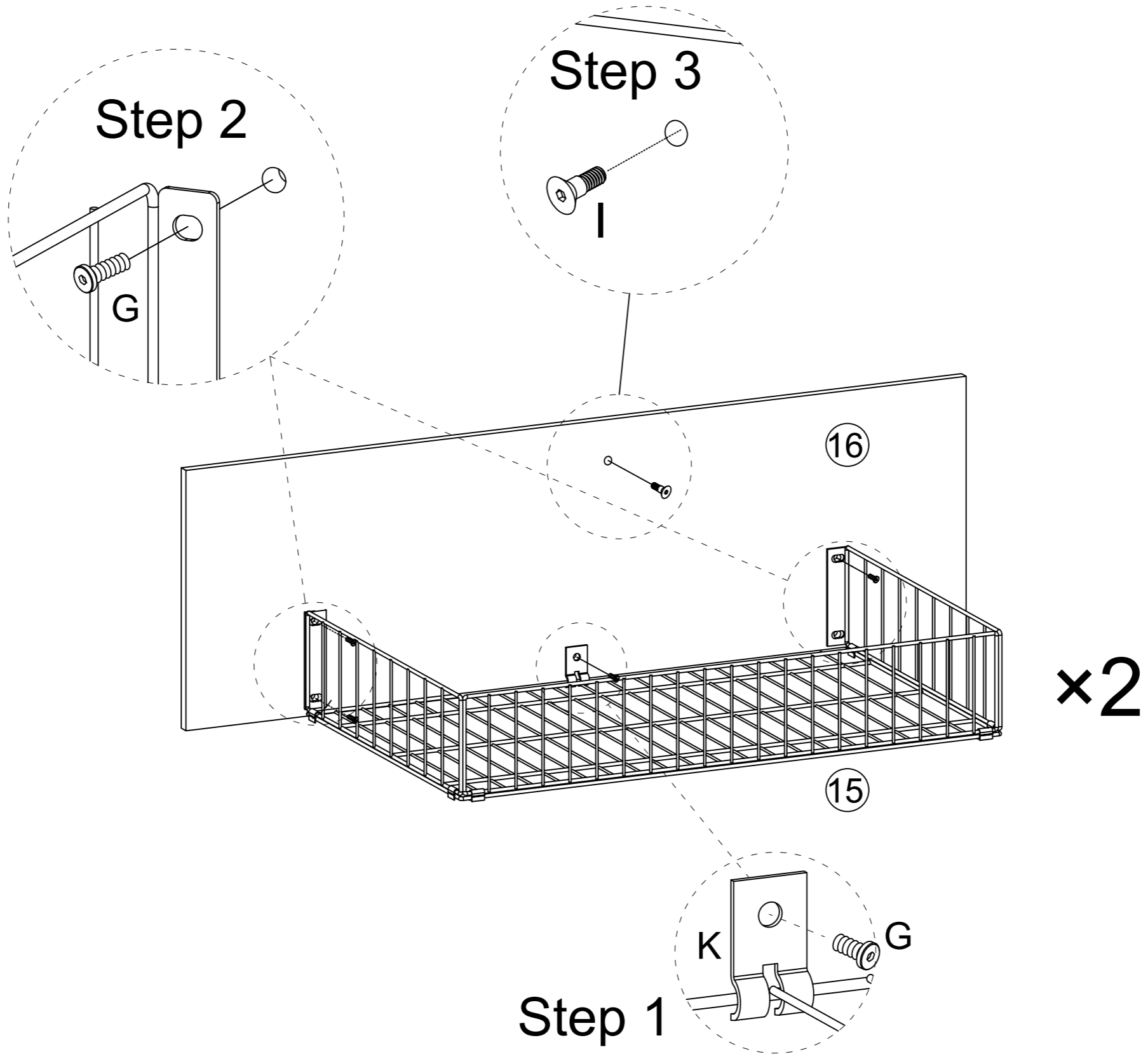

16

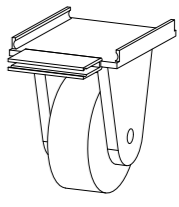
M  ×8

Clamp the wire with the opening of the front end of the wheel and press down to tighten the wire.

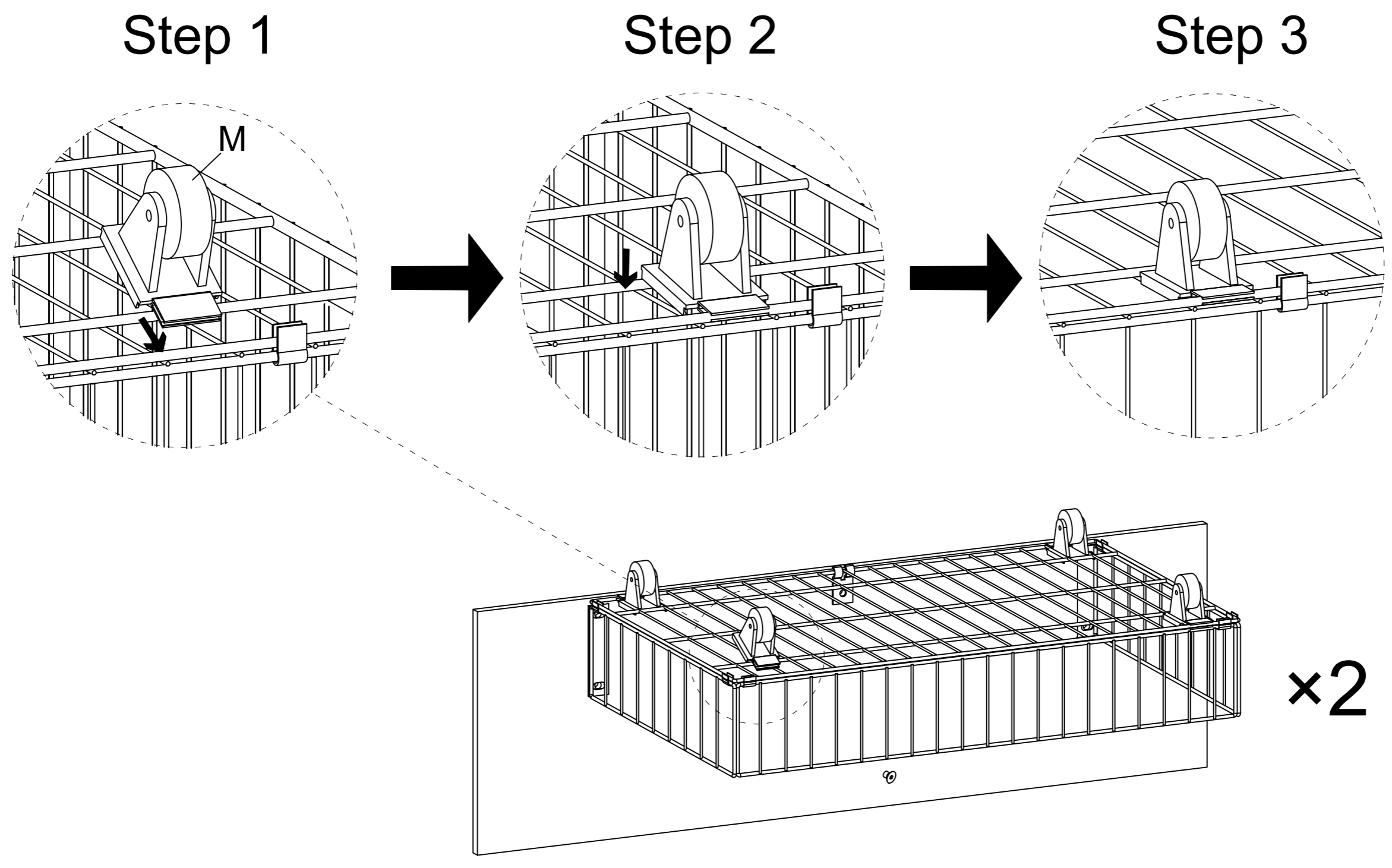

17

Carefully lift the drawer as you push it in. Please align the screw with the hole on the iron pipe and hang it up

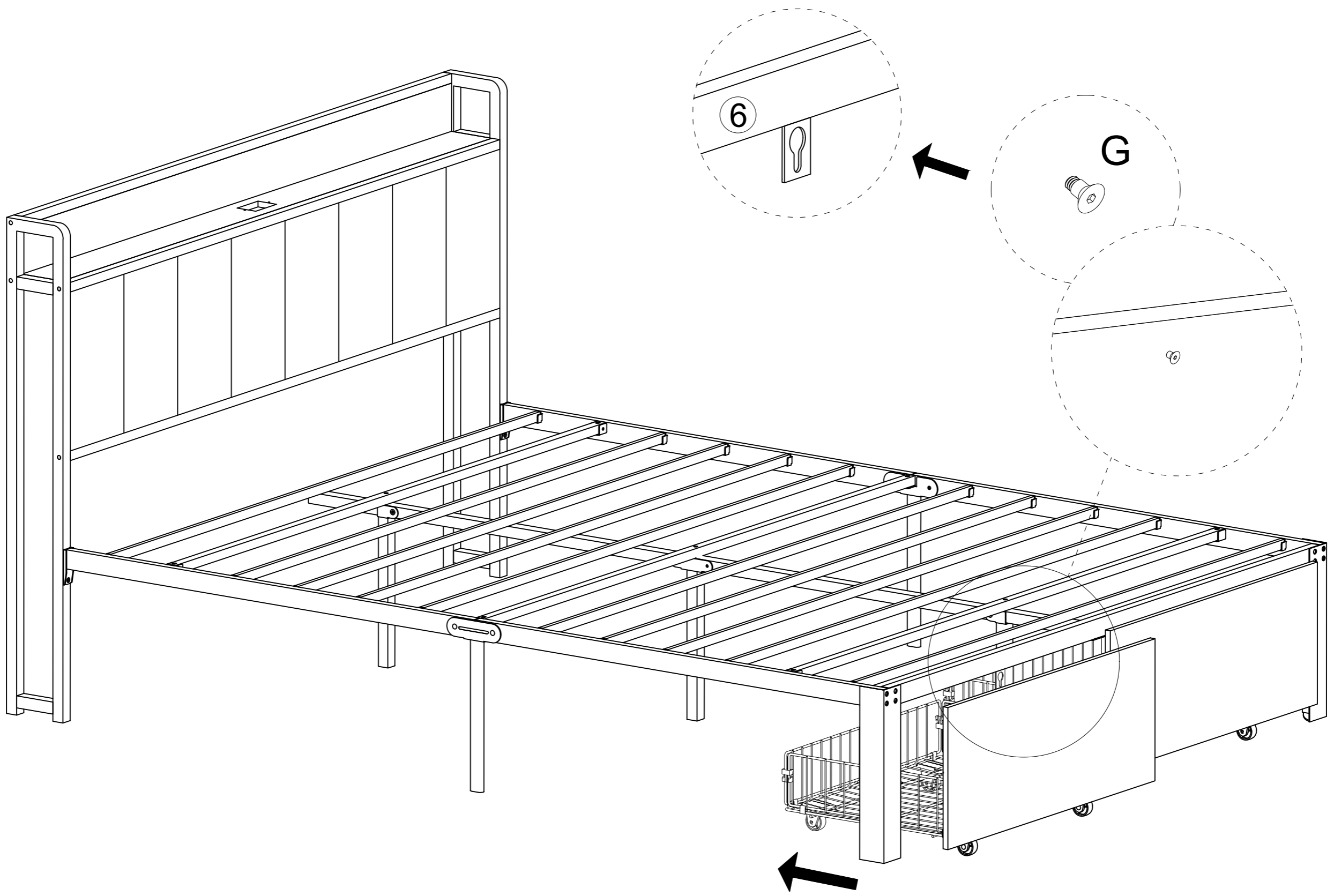

18

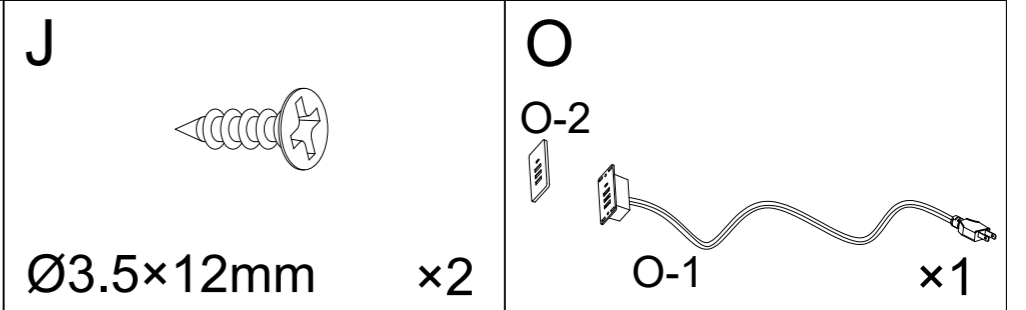

Step 1

Step 2

Press part O-2 onto part O-1

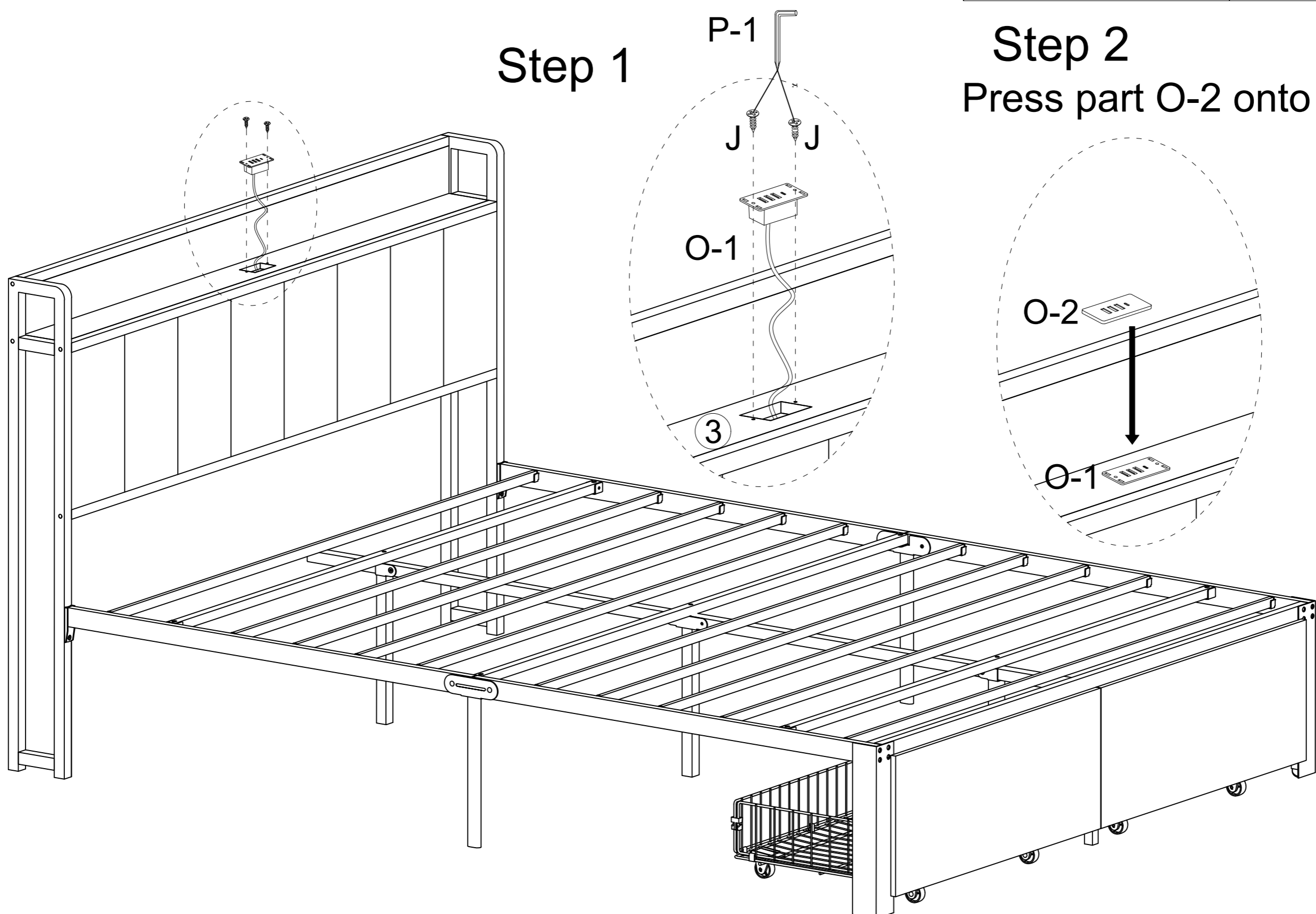

19

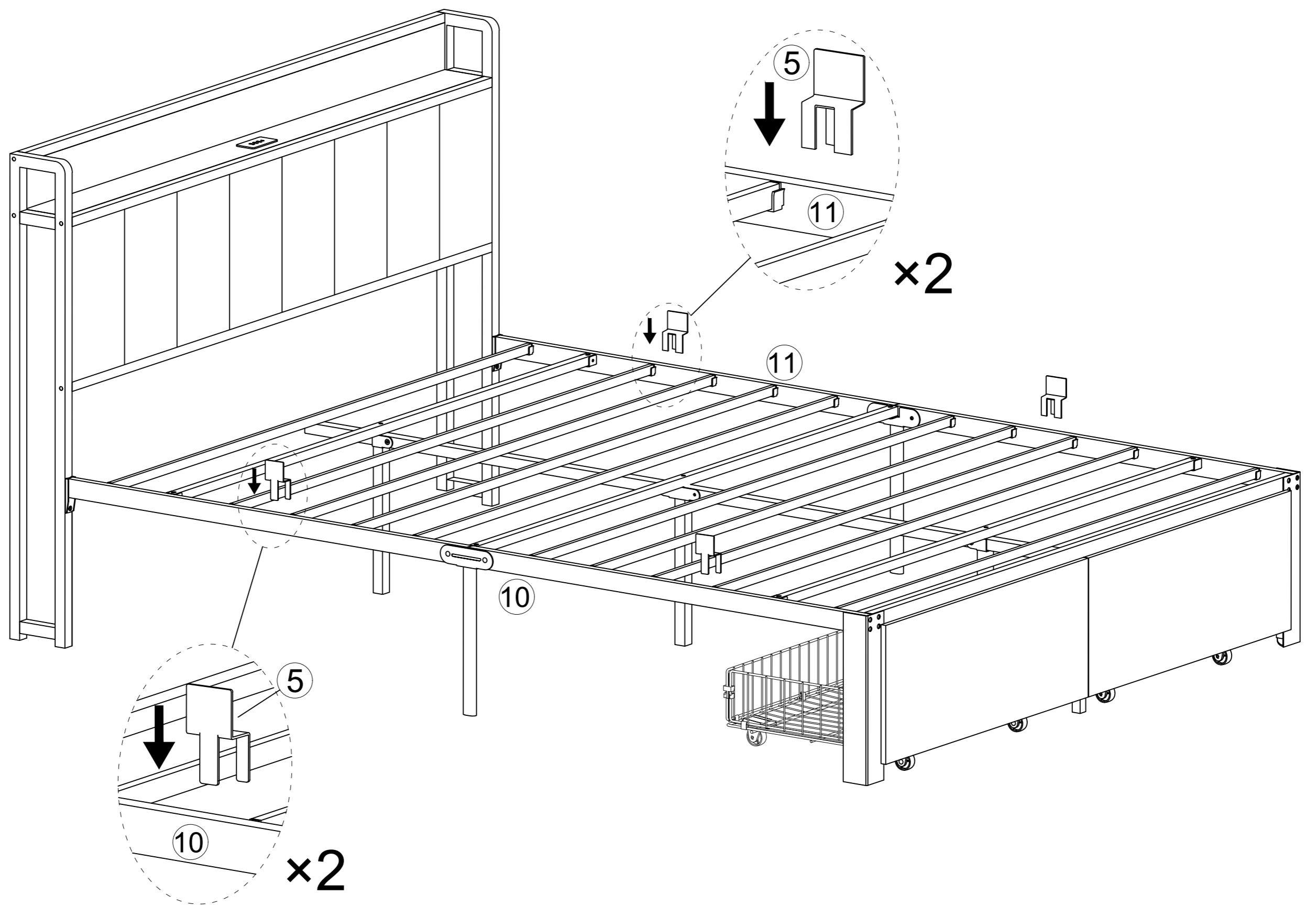

20

