

# PROBRITE®

## LED Security Flood Light

Catalog No. : FSNX80-PC-4K-BZ

Type : Flood/Wallpack

Project Name :

Location :

Qty :

Date :



PROBRITE's incredibly versatile and reliable LED Flood Light with optional wallpack mount kit offers a wide range of outdoor security lighting applications, including landscape lighting, building perimeter lighting, driveway, or even signage lighting. PROBRITE's FUSION X Dark Bronze 80-Watt LED Wall Pack offers 4000K of bright white light and emits 8000 Lumens of brightness, which is powerful enough to illuminate any space. The light comes with two mounting options, wall/eave mount using the mounting plate and swivel knuckle flood mount.

FLOOD MOUNT OPTION



### PRODUCT PERFORMANCE AT A GLANCE

| SYSTEM WATTAGE | LUMENS  | LPW      | CRI | REPLACES (Incandescent) |
|----------------|---------|----------|-----|-------------------------|
| 80W            | 8000 lm | 100 lm/w | >70 | 550W                    |



DUSK-TO-DAWN

#### HOUSING

Die cast aluminum housing with corrosion resistant powder-coated paint finish. It is designed to ensure cooling by natural convection and passive airflow, to let driver perform efficiently

#### IP RATING & LISTINGS

LED light engine is weather proof and water tight rated IP65. UL Listed, suitable for Wet Location.

#### OPTICS

Clear polycarbonate lens, does not alter beam and provide focused and clear lighting output.

#### MOUNTING

It can be mount on wall or eave and can also mount on ground as well with swivel knuckle flood mount.

#### FINISH

Fade, weather, and abrasion resistant, electrostatically applied, thermally cured, triglycidal isocyanurate (TGIC) textured polyester powdercoat bronze paint finish.

#### WARRANTY

Covered by a 5-year limited warranty. See [probrite.com/warranty](http://probrite.com/warranty) for details.

## PRODUCT SPECIFICATION

|                                 |   |
|---------------------------------|---|
| Product Dimensions              | : 11.03" x 8.46" x 2.03"                          |
| Weight                          | : 2.87 lbs  |
| Lumens                          | : 8000  |
| LED Wattage                     | : 80W   |
| Efficacy                        | : 100   |
| CRI                             | : >70   |
| Replaces (Incandescent)         | : 550W  |
| Mounting                        | : Wall Mount/Eave Mount                           |
| Frequency                       | : 50-60Hz   |
| THD (Total Harmonic Distortion) | : <20%  |
| PF(Power Factor)                | : >0.9  |
| Ambient Operating Temperature   | : (-30)-40°C                                      |
| Input Voltage                   | : 120-277V  |
| LED Chip                        | : -   |
| Photocell                       | : Yes   |
| Driver                          | : Non-dimming                                     |
| Standard Lifetime               | : 50,000 hrs                                      |
| Standard Warranty               | : 5 Years   |
| Water Proofing Grade            | : Suitable for wet location                       |
| CCT                             | : 4000K Bright White Light                        |
| Certifications                  | : IP 65, Energy Star, FCC Certified, UL Certified |

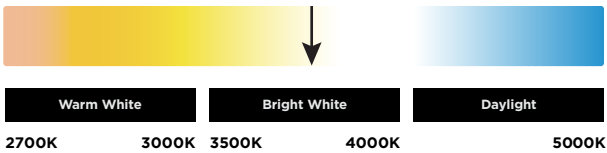

**SUGGESTED MOUNTING HEIGHT:**  
6-12 FT.(1.8-3.7 M)

### 3D PHOTOMETRIC VIEW

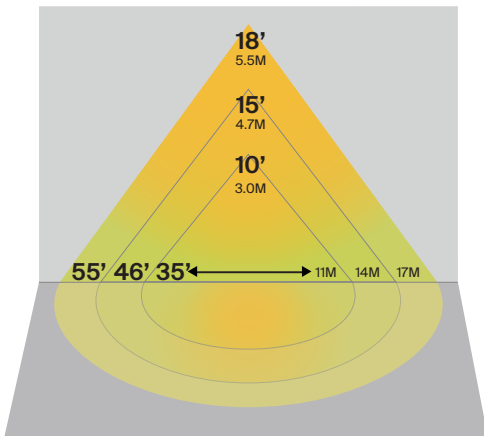

### PRODUCT LINE DRAWING

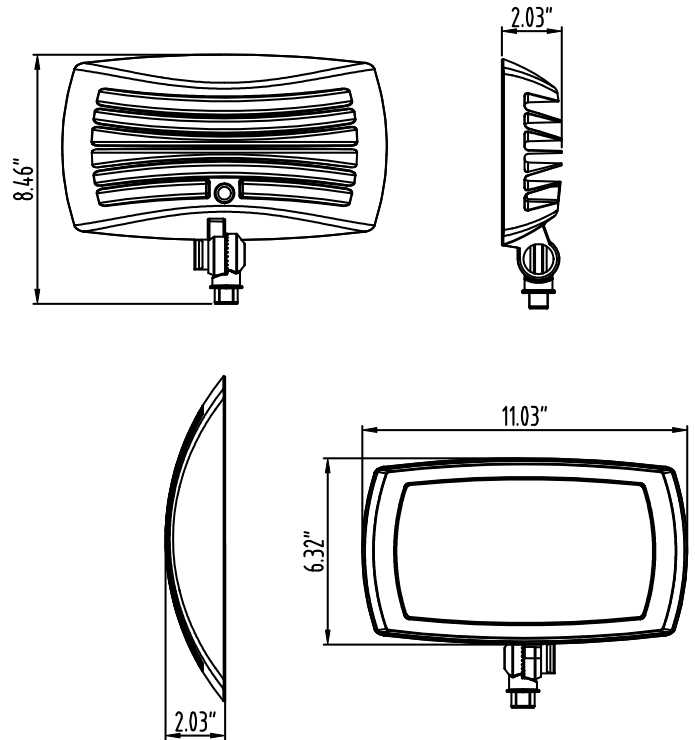

### APPLICATION

#### SUITABLE FOR MULTIPLE APPLICATIONS

- SECURITY • GENERAL LIGHTING • ENTRYWAYS
- DRIVEWAYS • BACKYARDS • SIGNAGE

