

6 X 10 X 6 Ft Green House Assembly Instructions

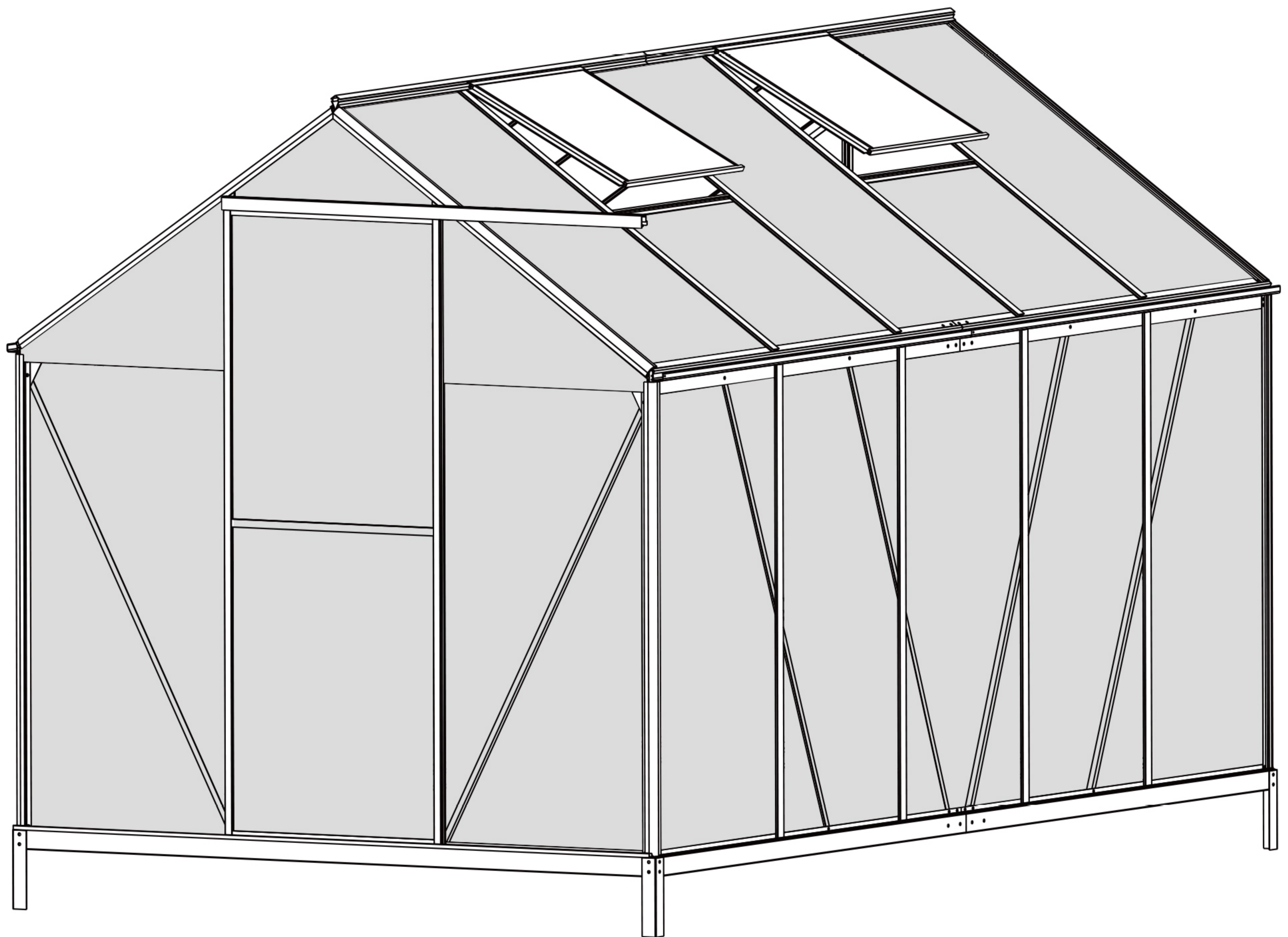

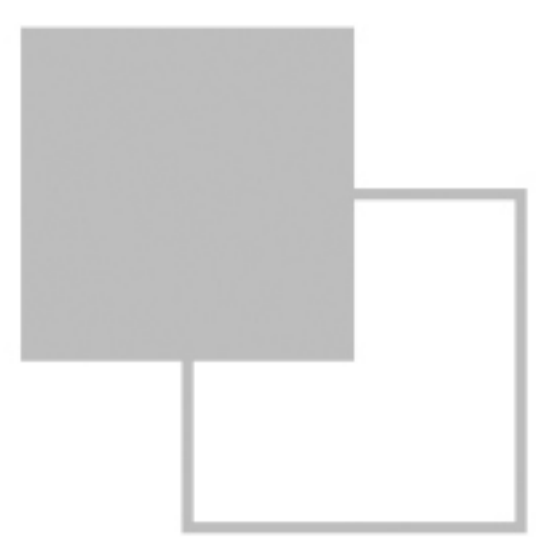

◆ General Advice	1
◆ Parts List	3
◆ Installation steps	
1) Front Assembly	5
2) Rear Gable Assembly	10
3) Side Wall Assembly	14
4) Roof Assembly	17
5) Vent Assembly	21
6) Door Assembly	24
7) Base Assembly	27
8) Base Connector Assembly	28

Kindly noted this item come with 2 packages, Please start assembling after receiving all the packages.
Please read the assembly manual and familiarize yourself with the parts and steps before assembling your Greenhouse .

IMPORTANT

The Greenhouse contains parts with sharp edges . Handle with care .
The all parts have sharp edges . Use safety work gloves while the whole assembly.
Do not assemble the greenhouse on a windy day .

Weather notice

The greenhouse must be reinforced under severe weather, such as typhoon, hurricane, sandstorm, etc.
Panel Frame Reinforcement: Use tape in the shape of "x" and then paste on the panel for reinforcement
Foundation Reinforcement: The best option is to use a concrete foundation for firmer installation.
If there is no way to use the concrete foundation to reinforce, it will lead to the deterioration of the wind resistance of the greenhouse
In extreme weather, the weight of the base must be increased by placing heavy objects to enhance wind resistance

NOTICE

It will take at least two adults about 5-6 hours to assemble the greenhouse .
We suggest use electric drill (NOT included) to make the whole assembly more quickly.
Follow the manual step by step .
Keep this manual for future reference .

TOOLS Required (NOT included)

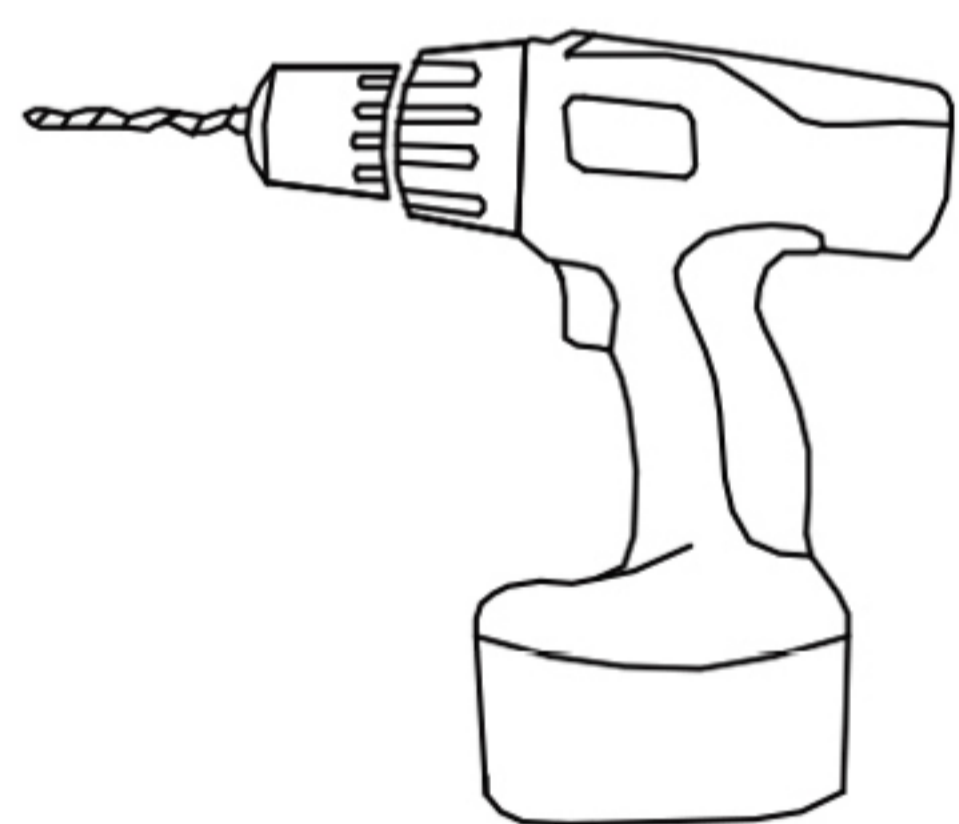

Power Drill

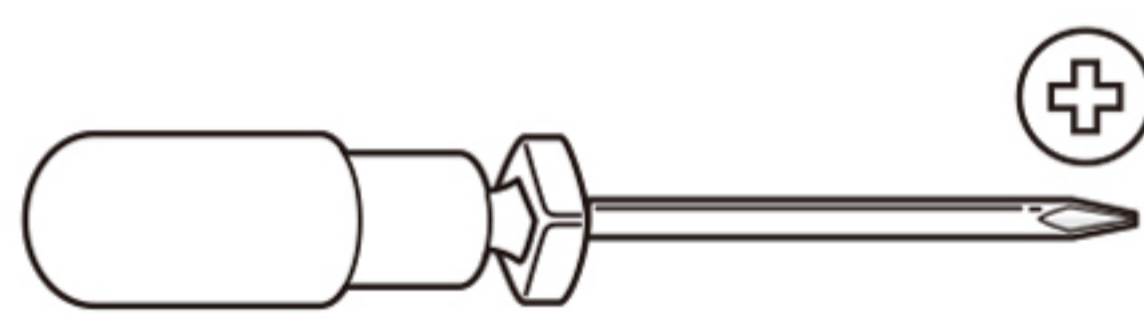

Phillips Screwdriver



Safety Work Gloves



Safety Goggles

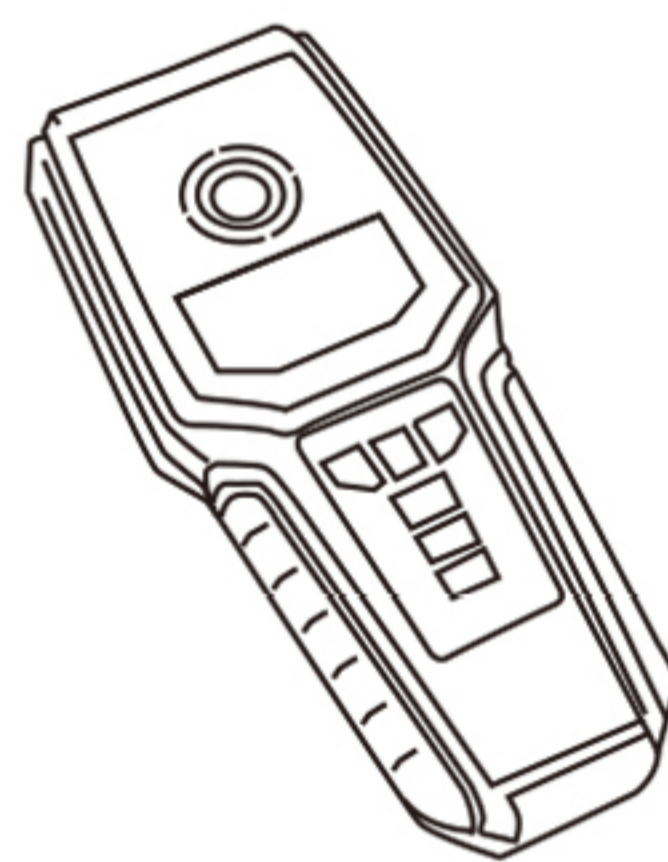

Spirit Level

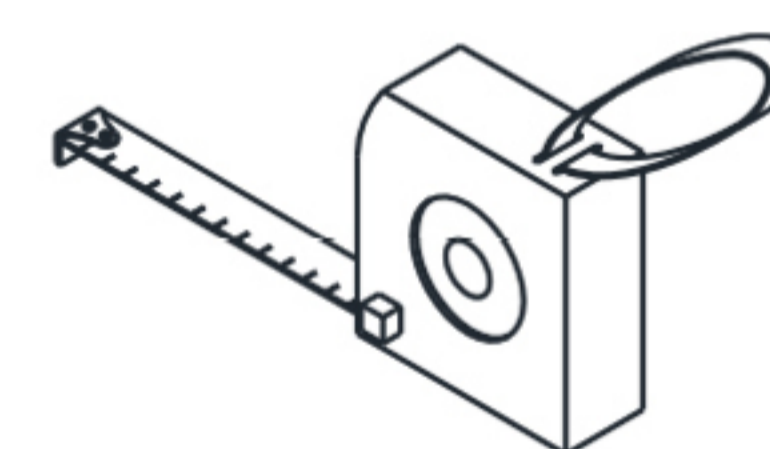

Tape Measure

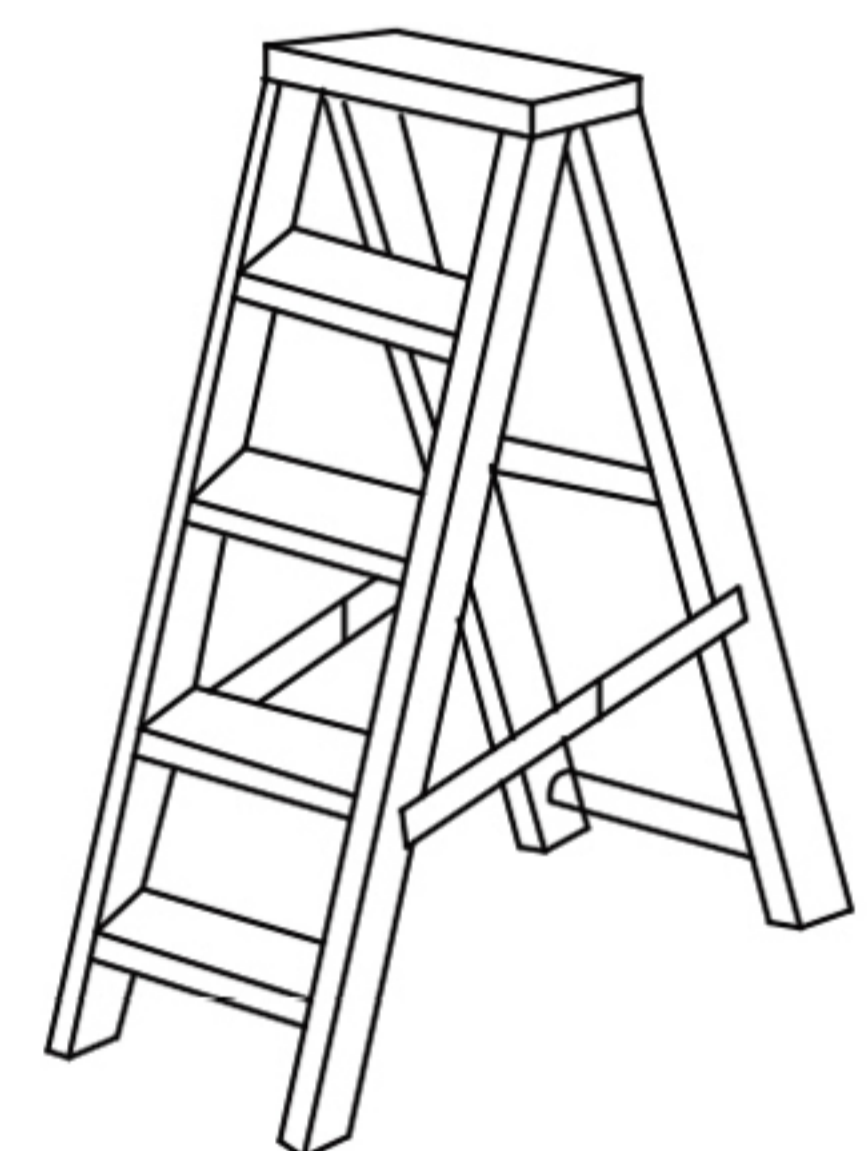

Step Ladders

GENERAL ADVICE

Note: There are 2 sides films on the Polycarbonate Panel.
One side is clear film, another side is white color film.

Need to Remove 2 side films from all edges before installing the Polycarbonate sheets .

Assembled Foundation Choose

As per your purchase choice , you may receive a greenhouse with or without a prefabricated base kit . Either way , this greenhouse must be secured to a firm base .

- 1.The Base must be level and square .
 - 2.Before assembling the greenhouse , you must prepare a proper foundation.
 - 3.The concrete foundation option is the best option for a stronger installation.**
- Other foundation option will lead to poor wind resistance of the greenhouse.**

Corner Stakes mounted into concrete

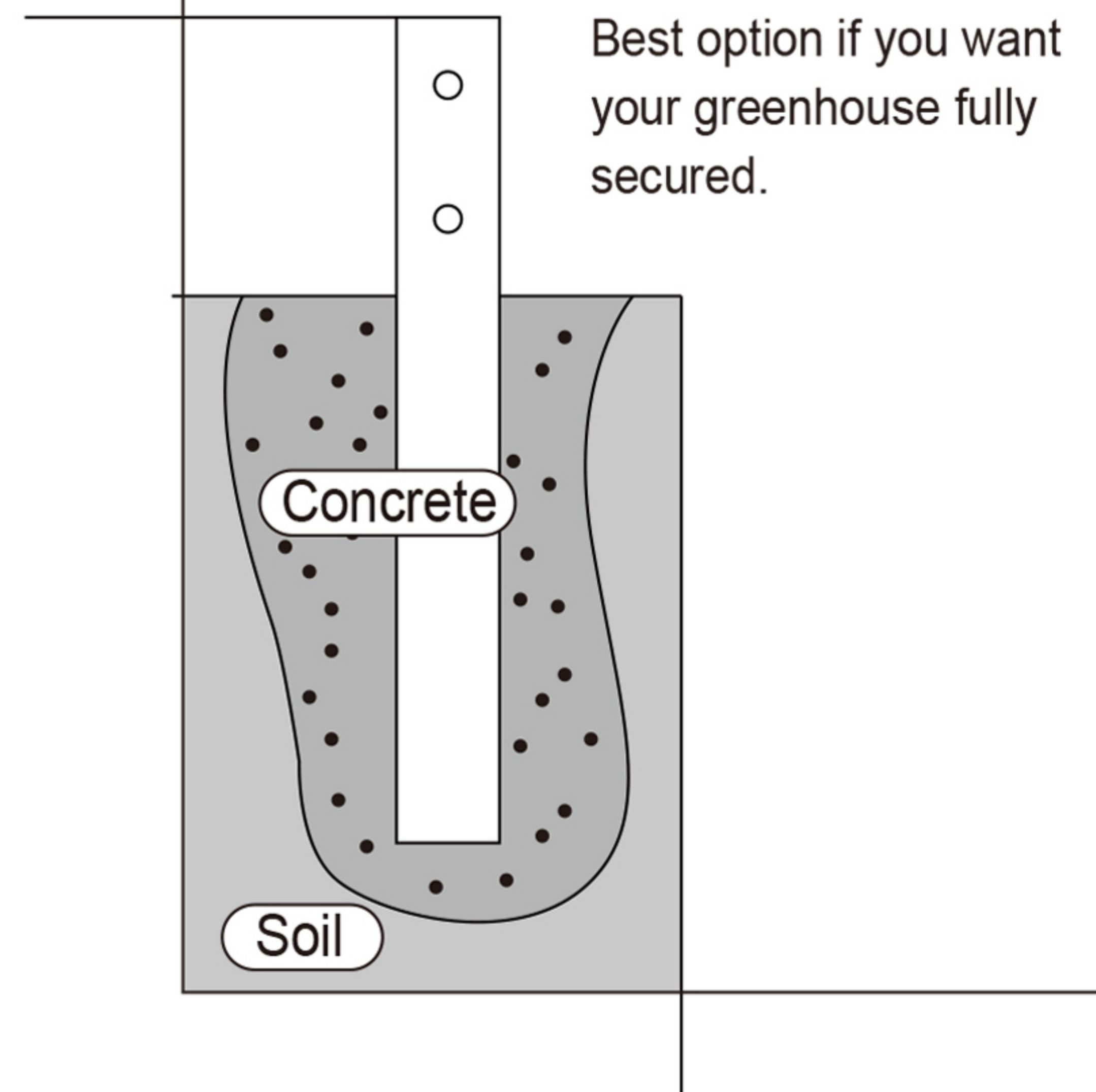

BOLT INSERTION

Several steps in this manual involve inserting Bolts into the groove of Aluminum profiles as a preparation for further installation . Diagrams above illustrate how to use such inserted bolts .

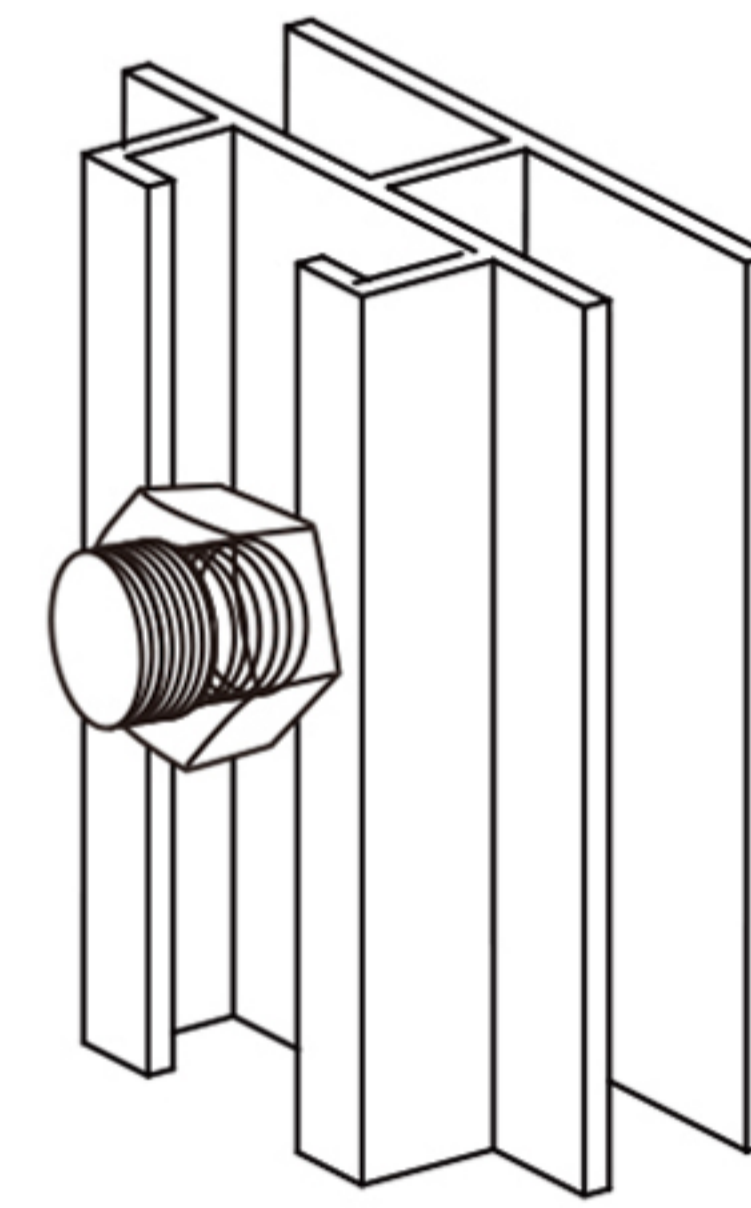
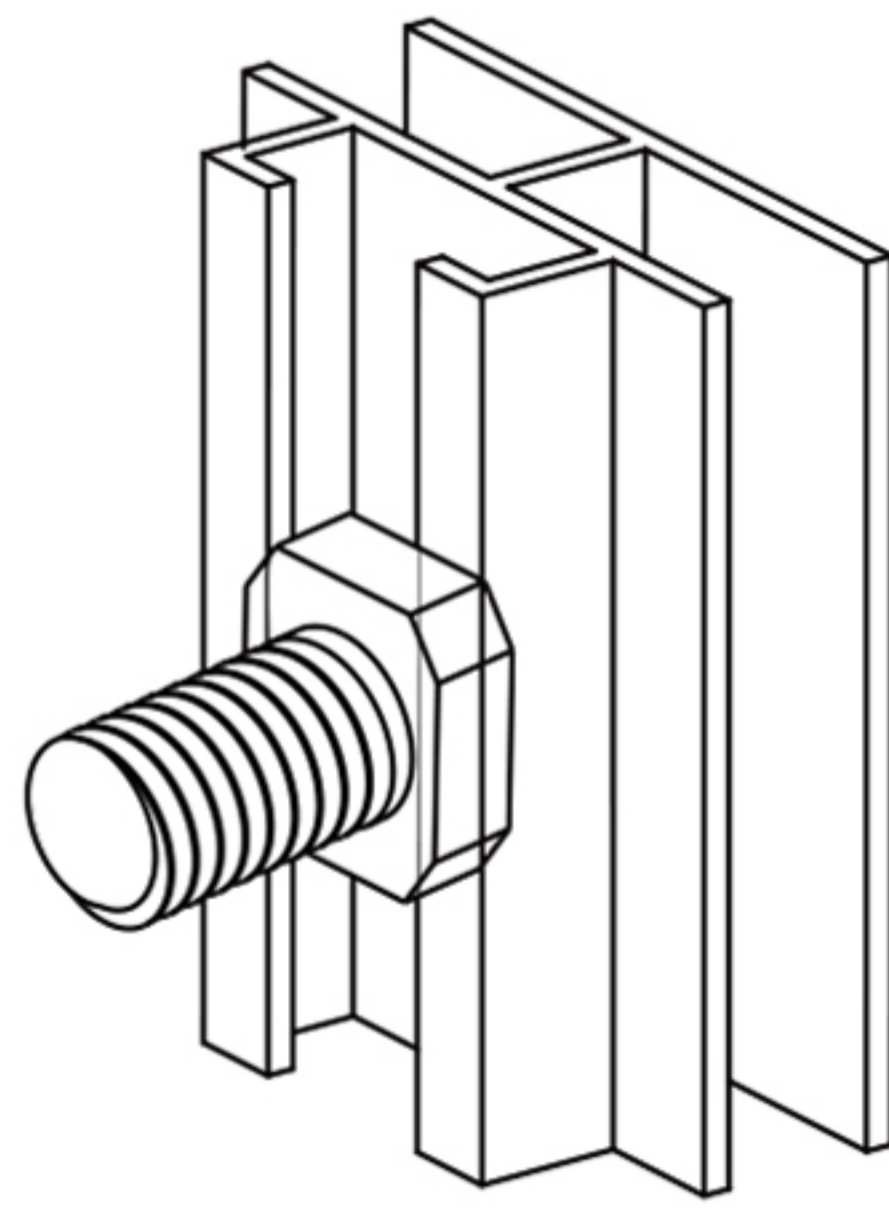
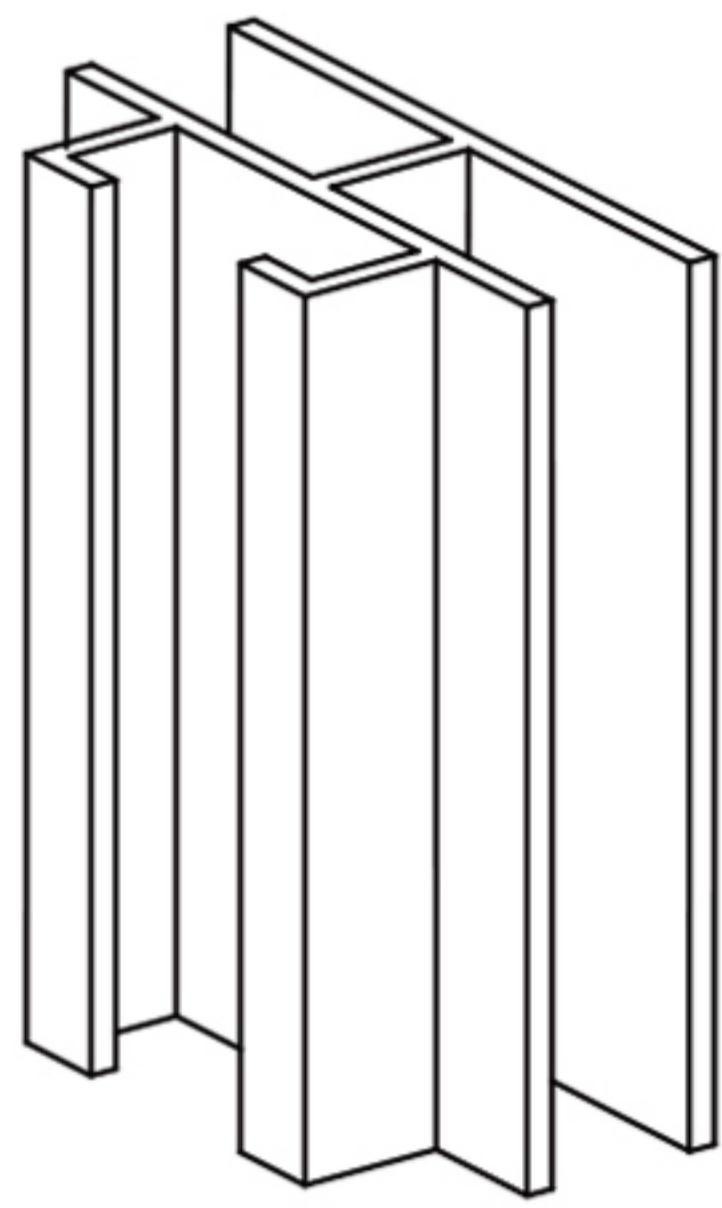
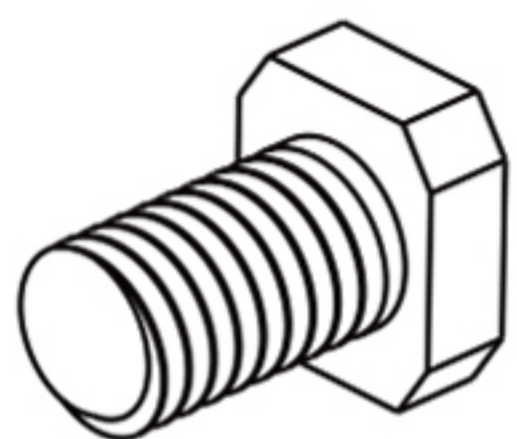

In some steps only bolt or the nut will be used and in other steps the whole set will be used . Check the specific Part List in each step .

SEALING

Sealing the greenhouse by applying glue or tapes between the Polycarbonate sheets and aluminum profiles will keep insects out and provide better stability against wind . Sealant and glue gun are Not included.

PARTS

Identify all parts using the parts list in this manual and labels on the parts . Prepared each part needed for that assembled step before working on that step .



Identify all parts using the parts list in this manual and labels on the parts . Prepared each part needed for that assembled step before working on that step .

Base Part List

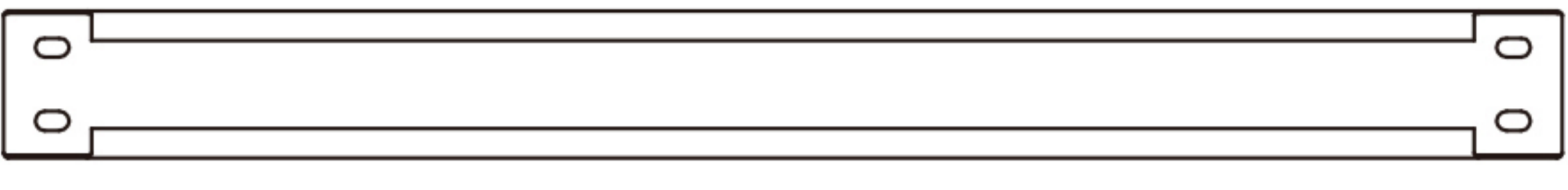
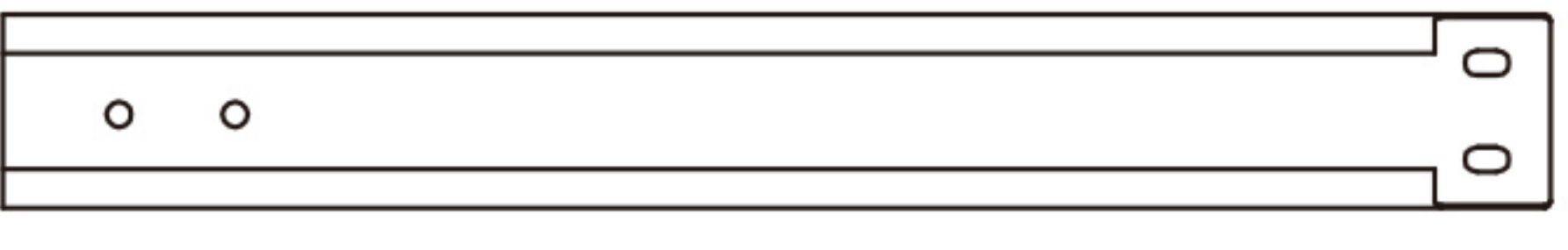
B01 2PCS 	B029 4PCS 
--	--

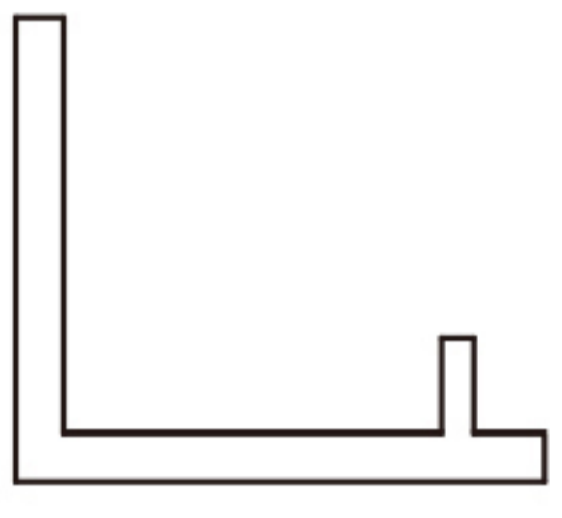
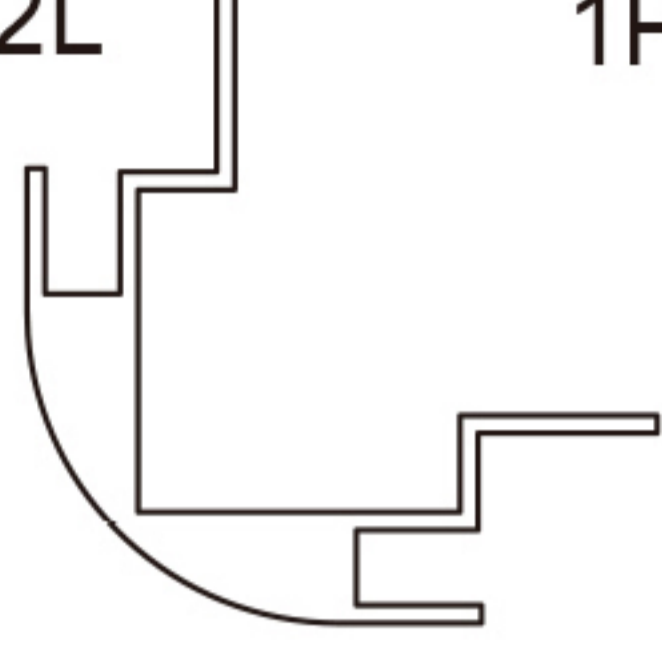
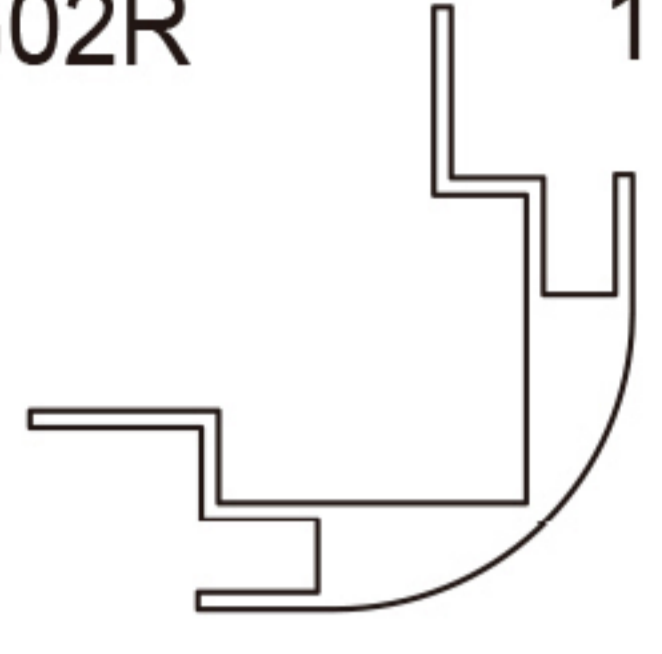
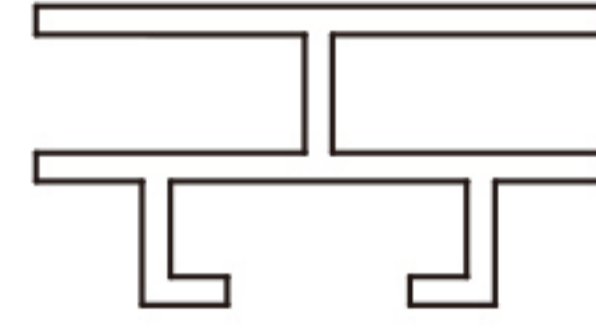
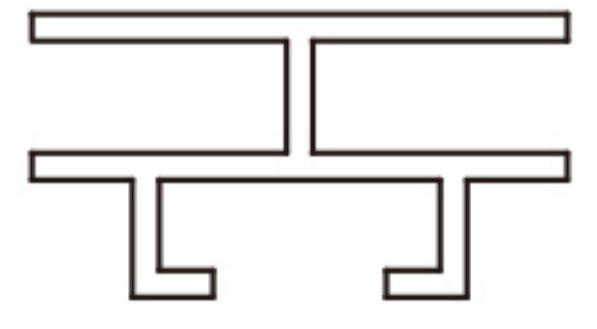
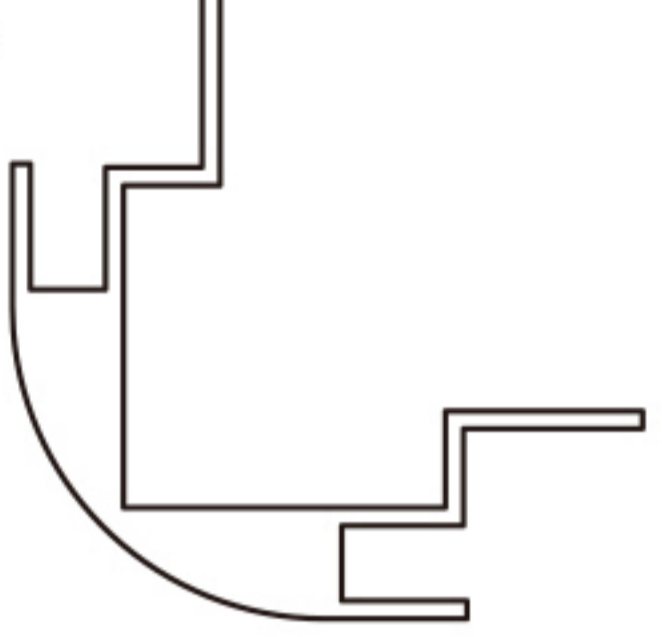
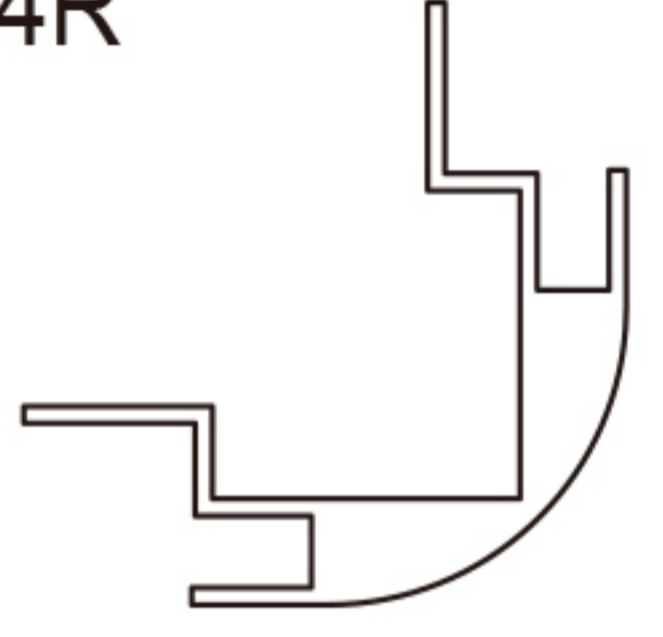
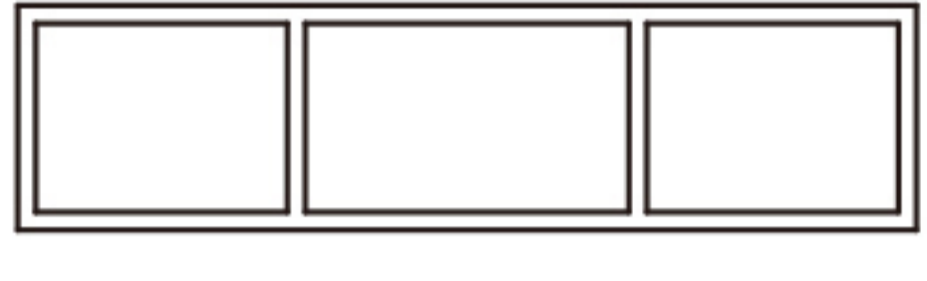
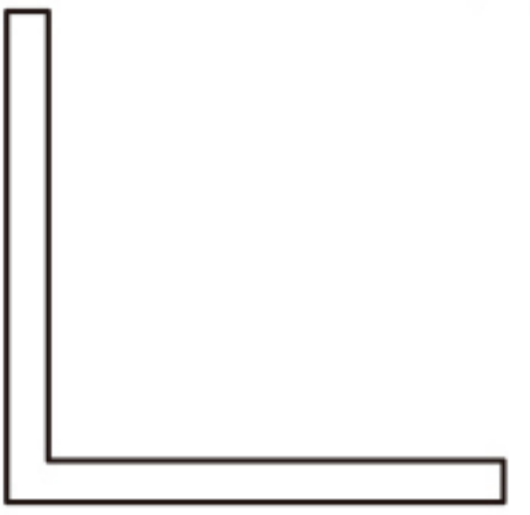

Rear Gable Part List

RG01 1PC 	RG02L 1PC 	RG02R 1PC 	RG03L 1PC 	RG03R 1PC 
RG04L 1PC 	RG04R 1PC 	RG05 1PC 	RG06 2PCS 	

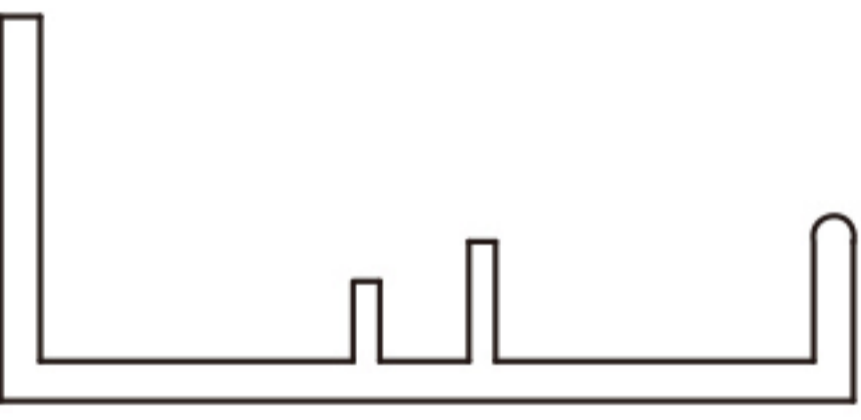
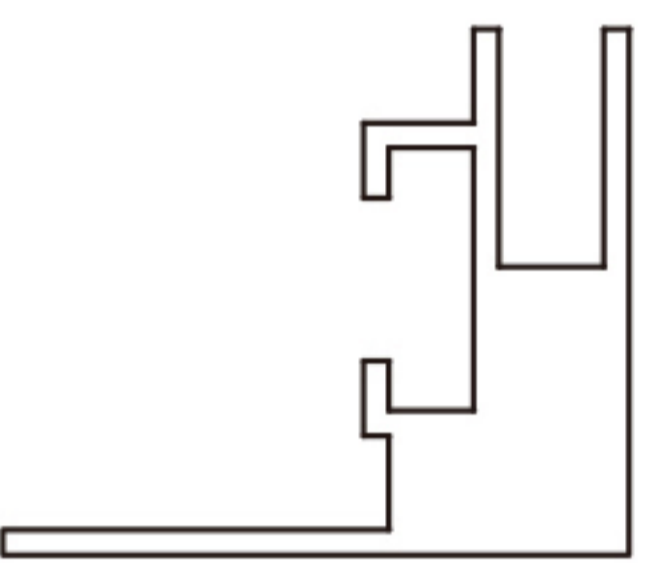
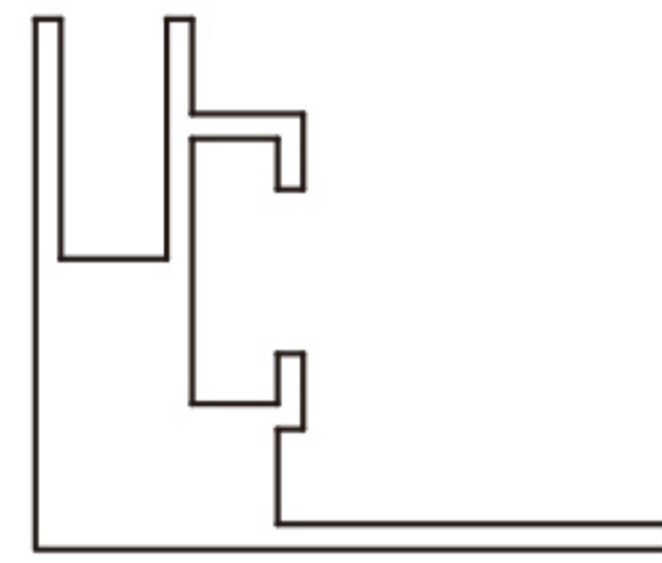
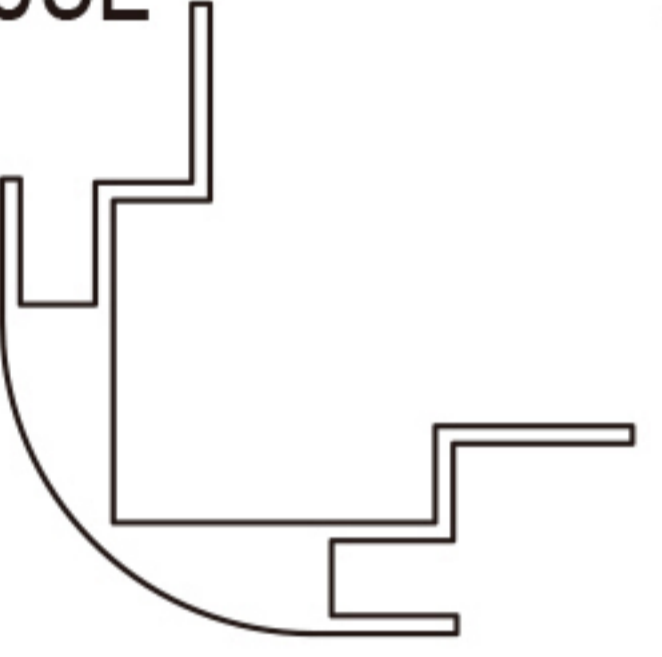
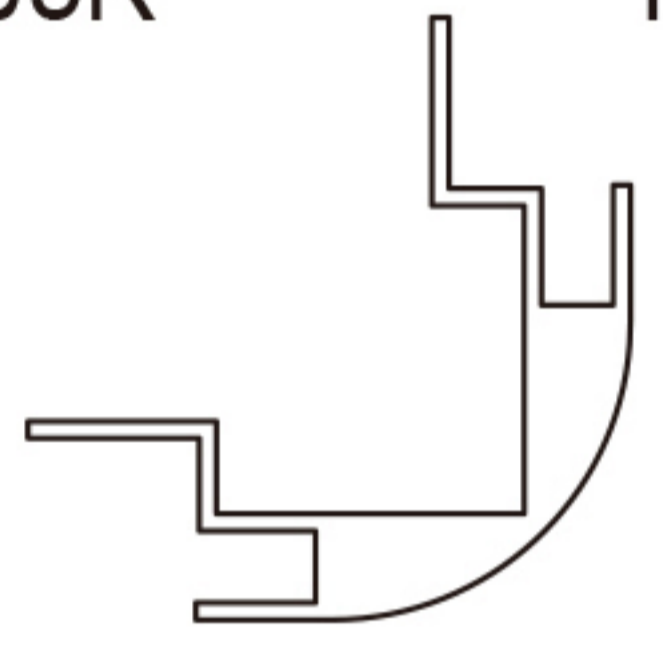
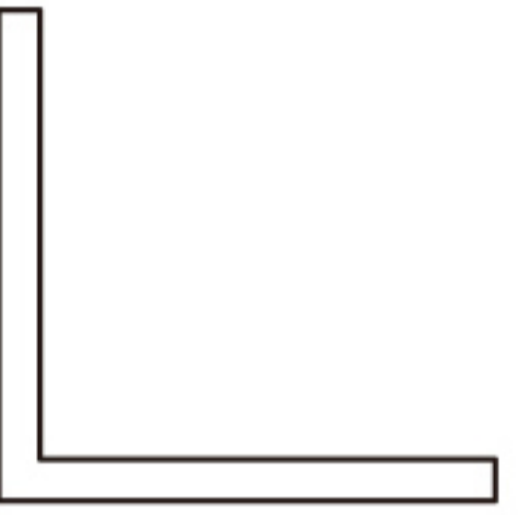
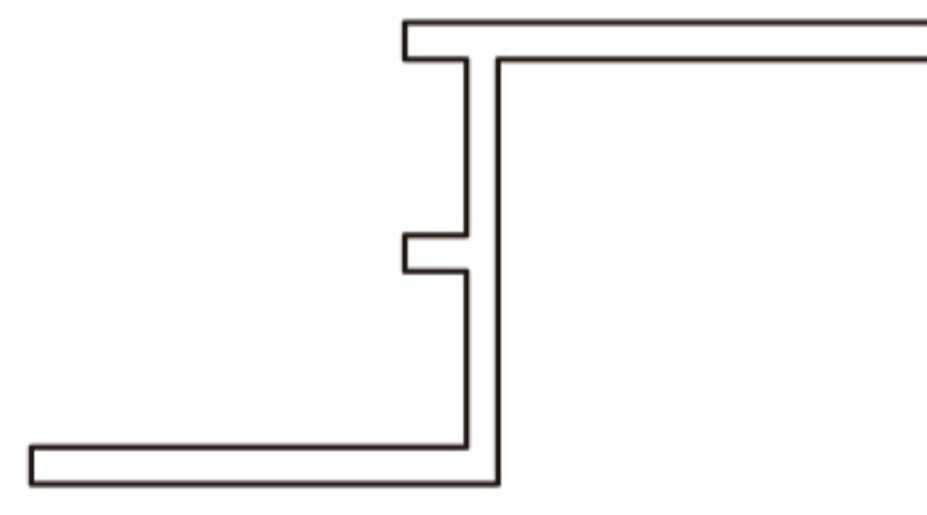
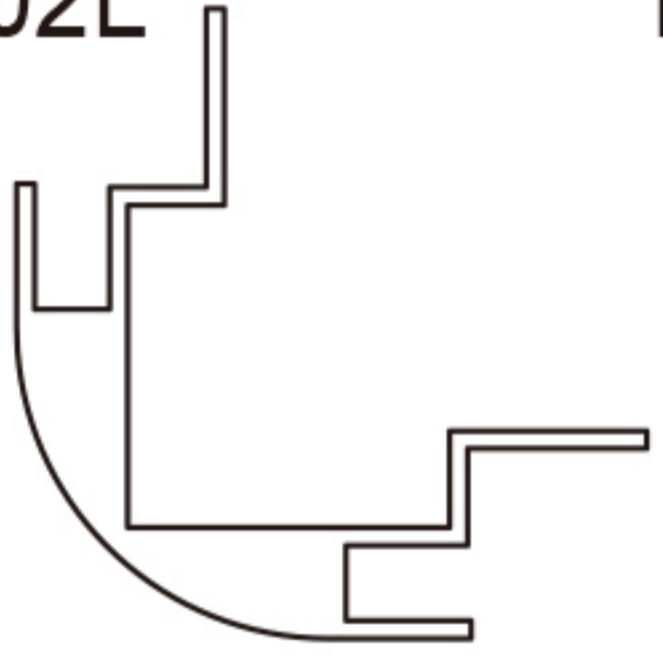
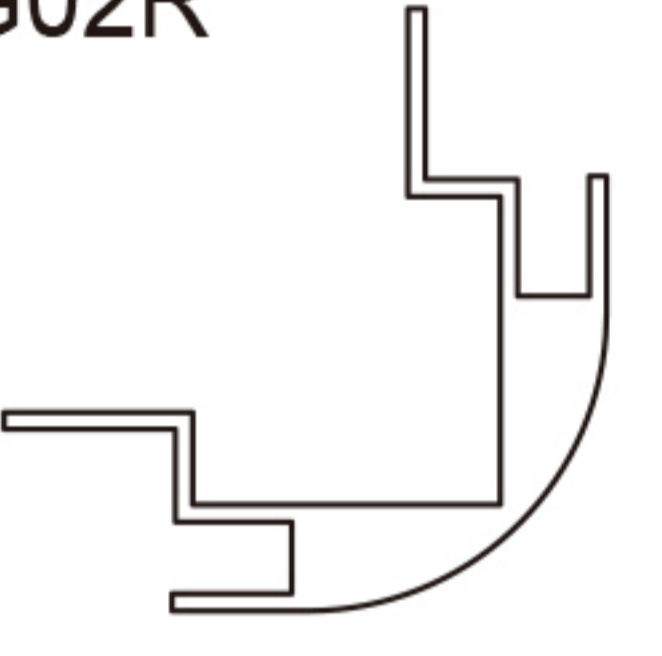
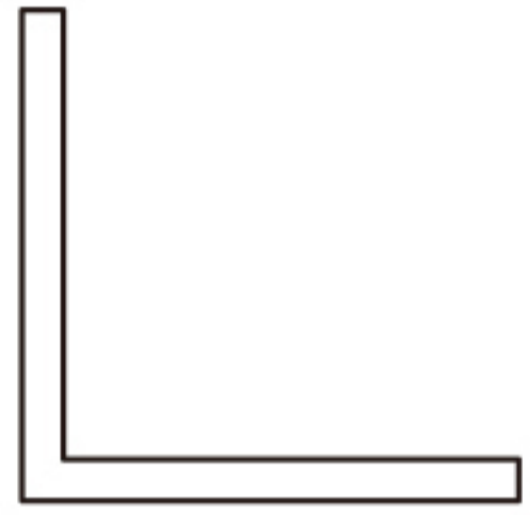
Front Gable Part List

FG01 1PC 	FG02L 1PC 	FG02R 1PC 	FG03L 1PC 	FG03R 1PC 
FG04 2PCS 	FG05 1PC 	RG02L 1PC 	RG02R 1PC 	RG06 2PCS 

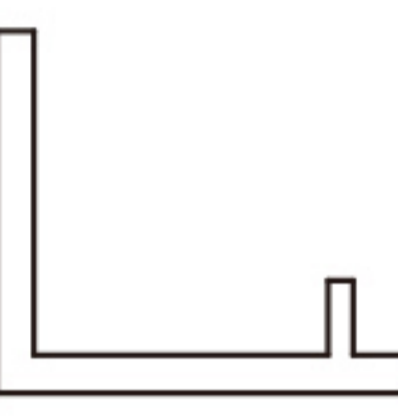
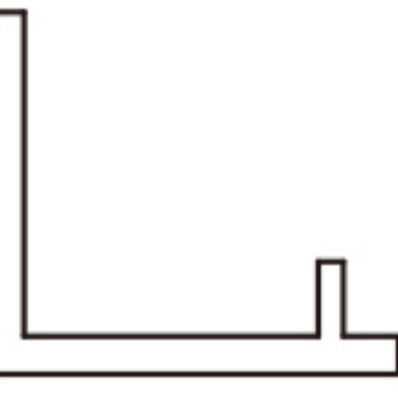
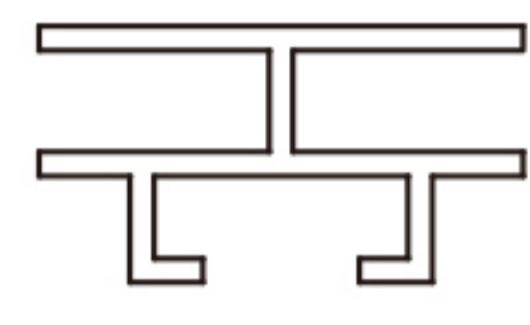
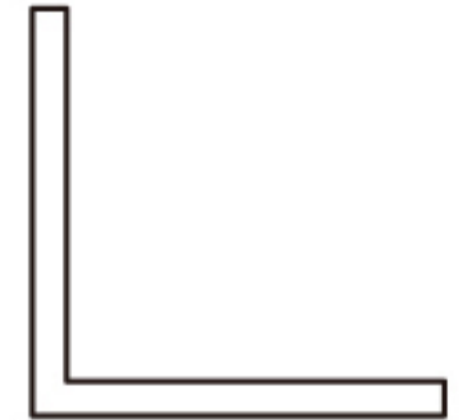

Side Wall Part List

SG383 2PCS 	SG384 2PCS 	SG019L 2PCS 	SG019R 2PCS 	SG02 8PCS 	SG04 8PCS 
---	---	--	--	--	--

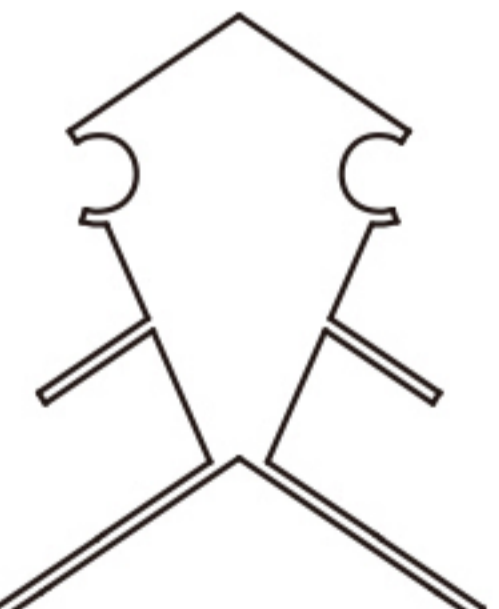
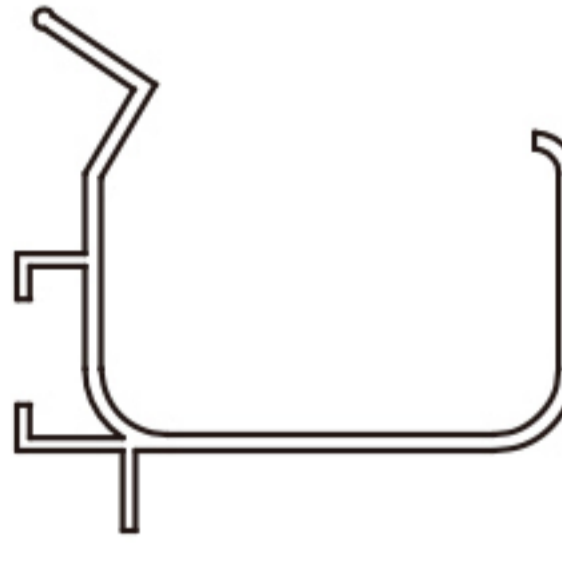
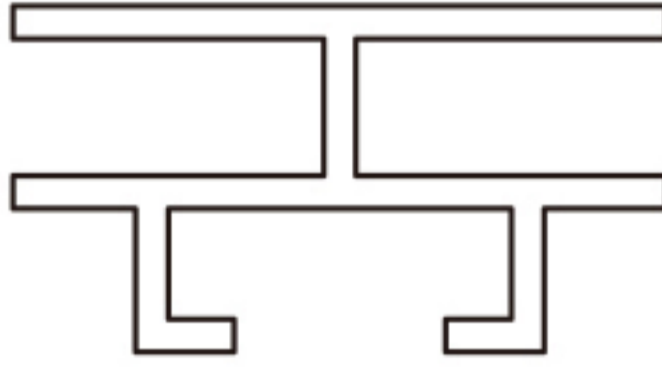
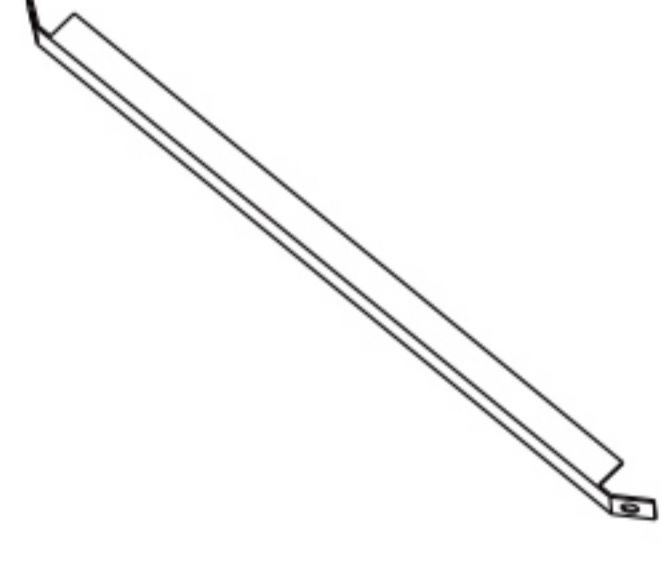
Roof Part List

R0183 2PCS 	R029 4PCS 	SG02 8PCS 	SR06 4PCS 
---	--	--	--

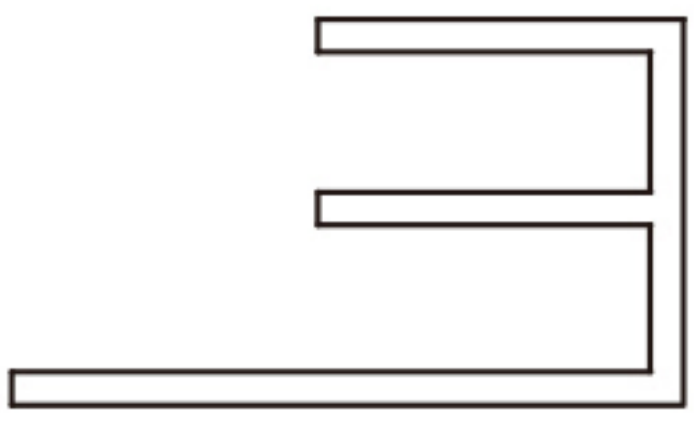
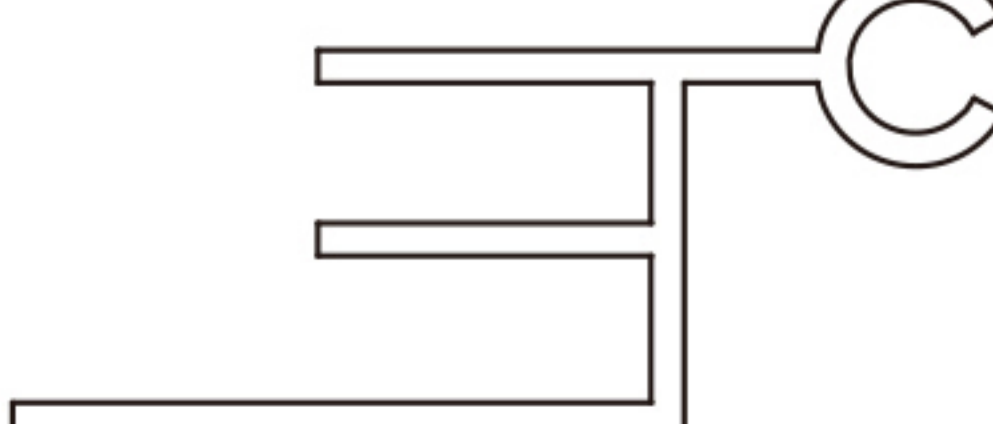
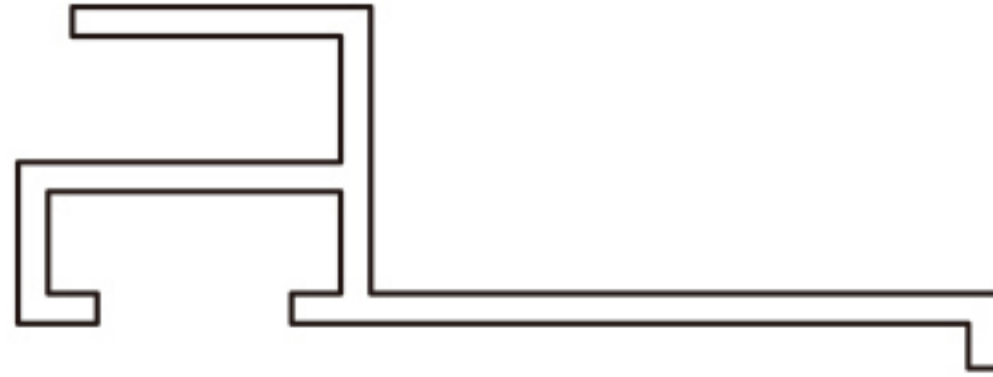
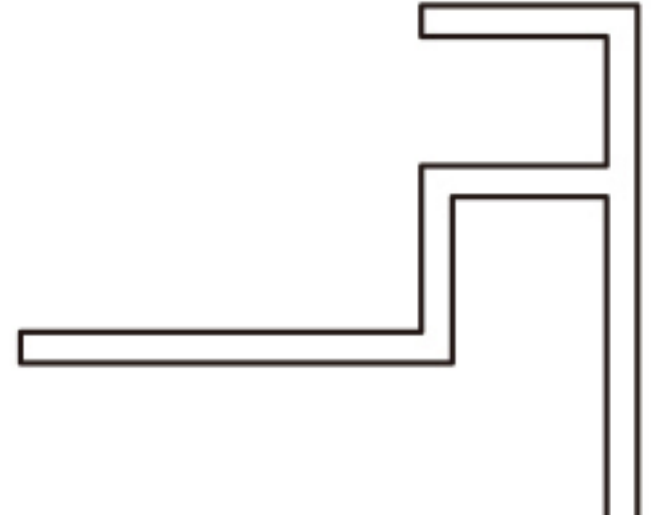





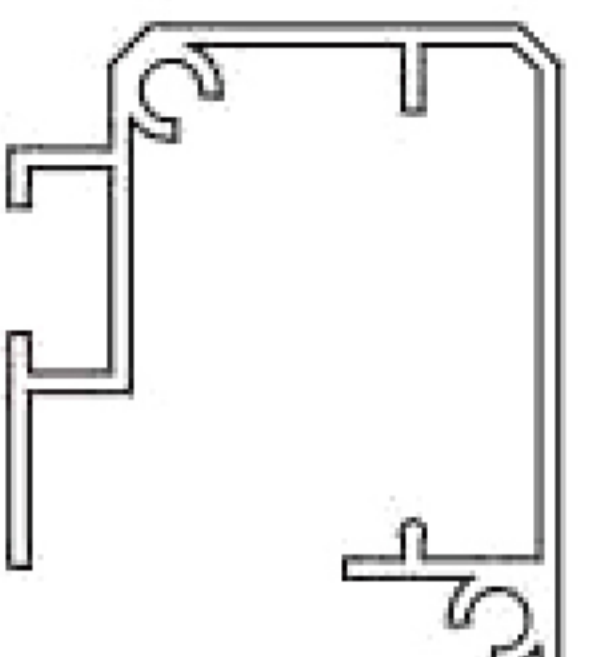
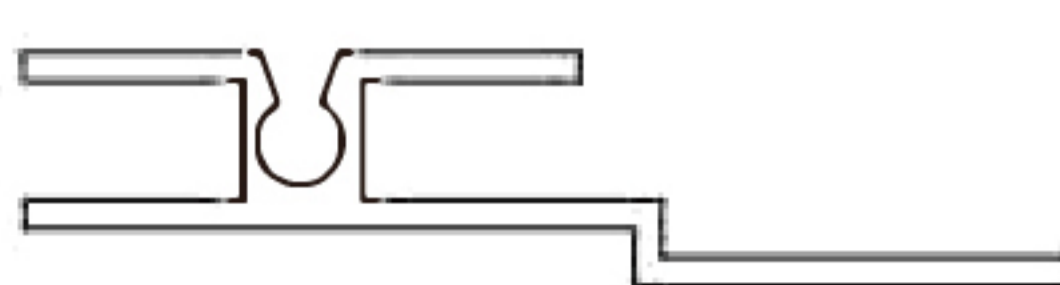
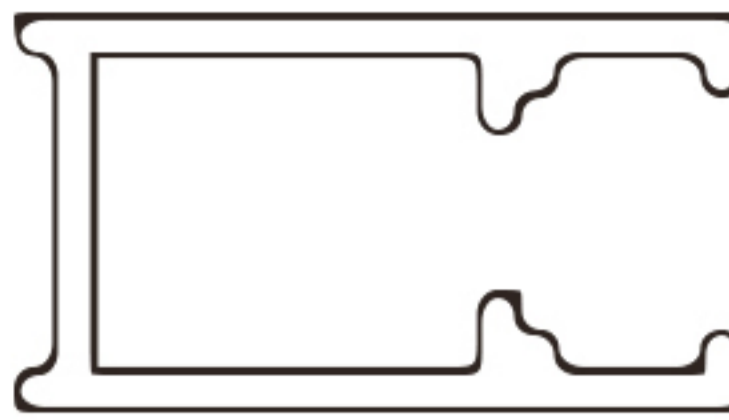
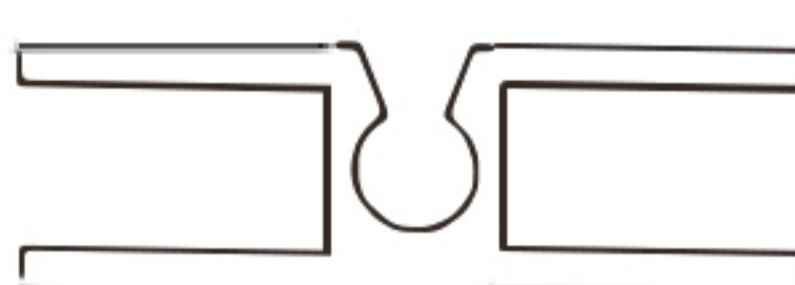

Vent Part List

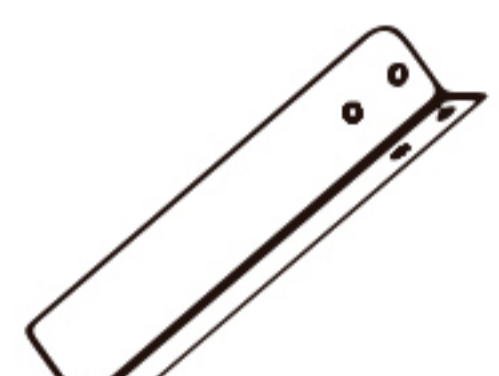
V02 2PCS 	V03 2PCS 	V04 4PCS 	V016 2PCS 	V017 2PCS 
---	---	--	--	--

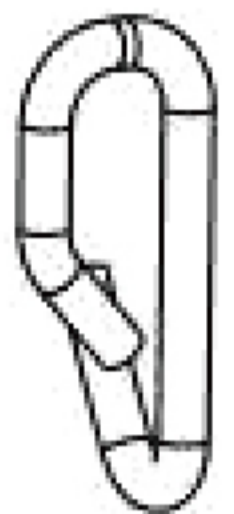





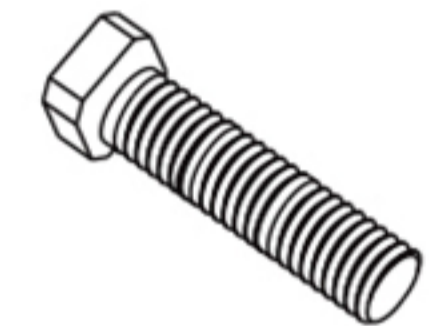

Door Part List

D01  1PC	D02  1PC	D03  2PCS	D04  2PCS
---	---	--	--



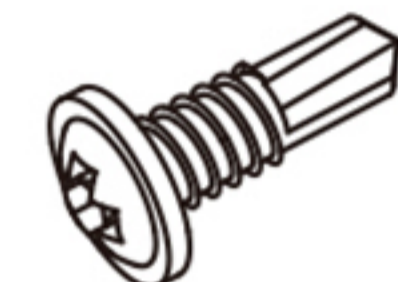



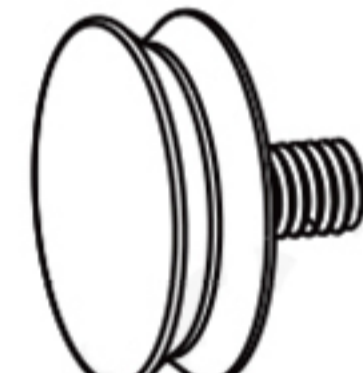
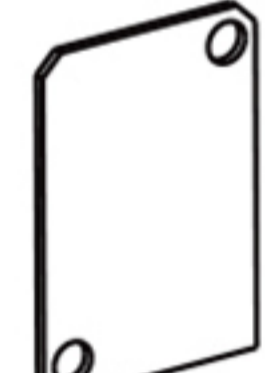

Connector Part List

BJ01 4PCS 	BJ02 2PCS 	BJ03 20PCS 	BJ04 2PCS 	BJ05 4PCS 	BJ06 2PCS 	BJ07 2PCS 	BJ08 1PC 
--	--	---	--	--	--	--	---



Screw Part List

LD01 4PCS  M6x18	LD02 196PCS  M6x12	LD03 10PCS  ST3.5x25	LD04 4PCS  M4X15	LD05 4PCS 	LD06 40PCS  M4.2x25	LM01 202PCS  M6	LM02 4PCS  M4
--	---	---	--	--	--	---	--

Other Part List

KT 15PCS 	GL01 2PCS 	TP01 2PCS 	CT01 2PCS 	SL01 2PCS 	SL04 2PCS 	SL05 2PCS 	SL06 2PCS 	SL07 40PCS 	SL08 40PCS 	SL09 2PCS 
---	--	--	--	--	--	--	--	---	---	--

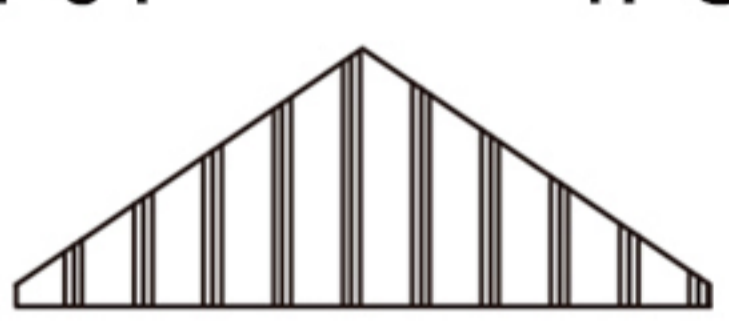
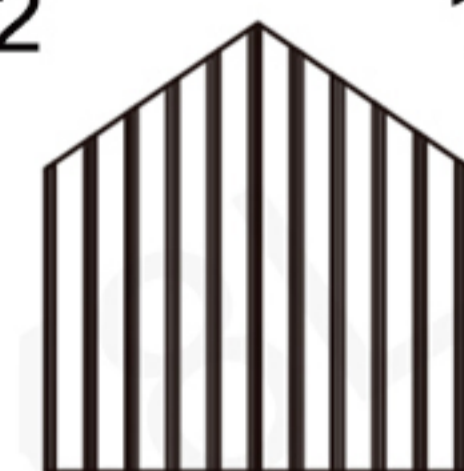
PC Panel Part List

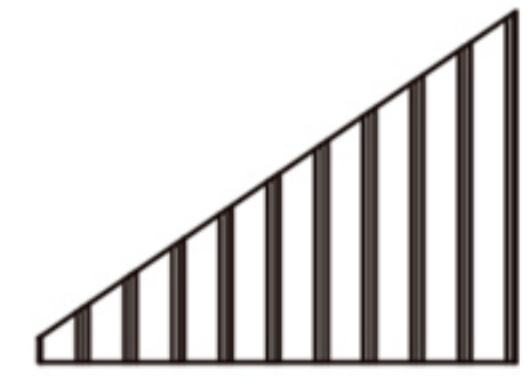
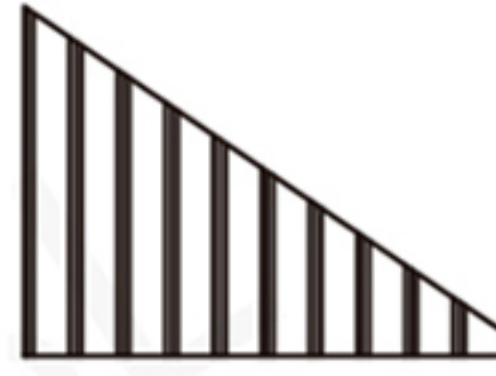
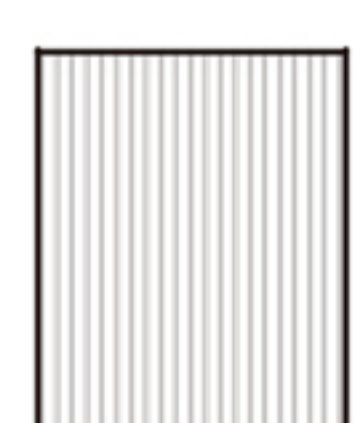
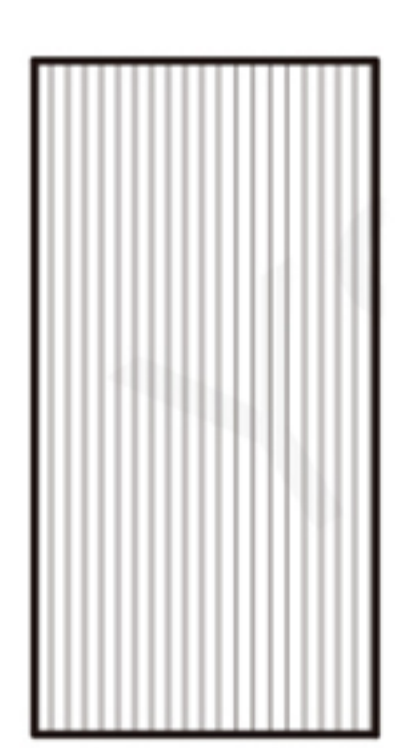
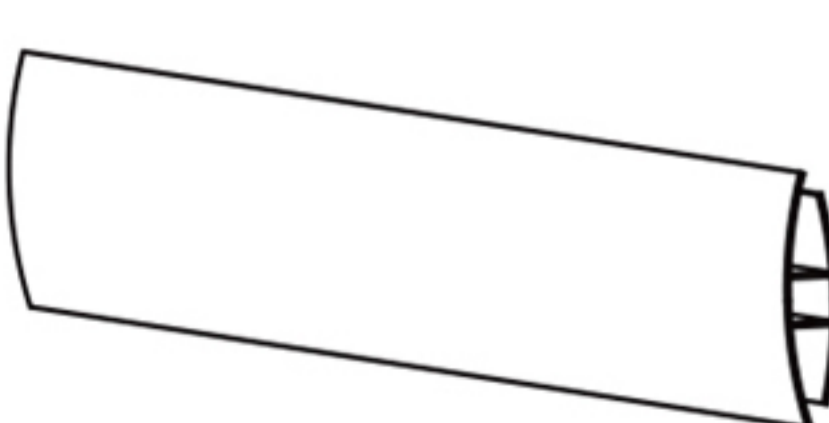
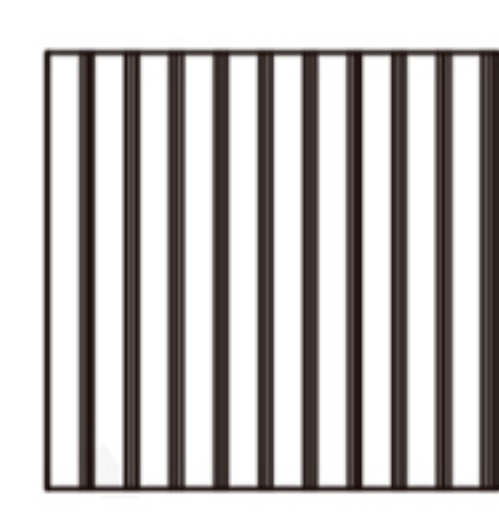
P01 1PC  8.8"x22.7"x0.16"	P02 1PC  25.7"x23.8"x0.16"	P03 2PC  23"x24"x0.16"	P04 2PC  17.6"x23.8"x0.16"	P05 2PC  17.6"x23.8"x0.16"	P06 2PC  30.7"x24.5"x0.16"	P07 23PC  47"x24"x0.16"	P08 5PC 	P09 2PC  22"x20.4"x0.16"
--	---	--	---	---	---	--	--	---

Front Gable Assembly

FG01 1PC	FG02L 1PC	FG02R 1PC	FG03L 1PC	FG03R 1PC	FG04 2PCS
FG05 1PC	RG02L 1PC	RG02R 1PC	RG06 2PCS	BJ05 2PCS	BJ04 1PC
P04 1PC	P05 1PC	P01 1PC	P08 2PCS	KT 2PCS	LD02 20PCS
P07 2PCS	LM01 20PCS				
17.2"x23.6"x0.16"	17.2"x23.6"x0.16"	8.8"x22.7"x0.16"		M6x12	M6

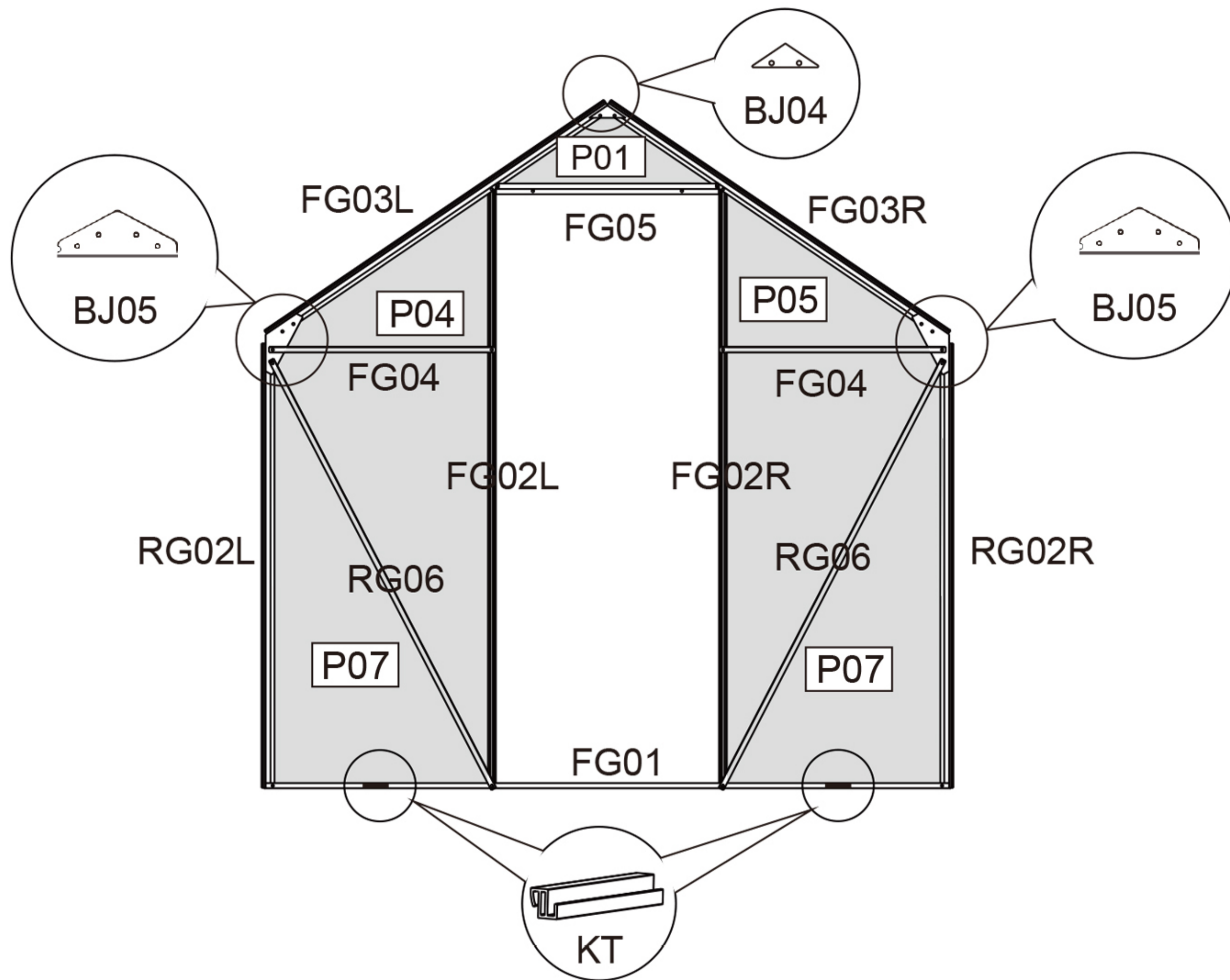

STEP 1

Connect RG02L, FG01 and RG02R with Nut LM01 and Bolt LD02.

- RG02L*1
- RG02R*1
- FG01*1
- LD02*2
- LM01*2

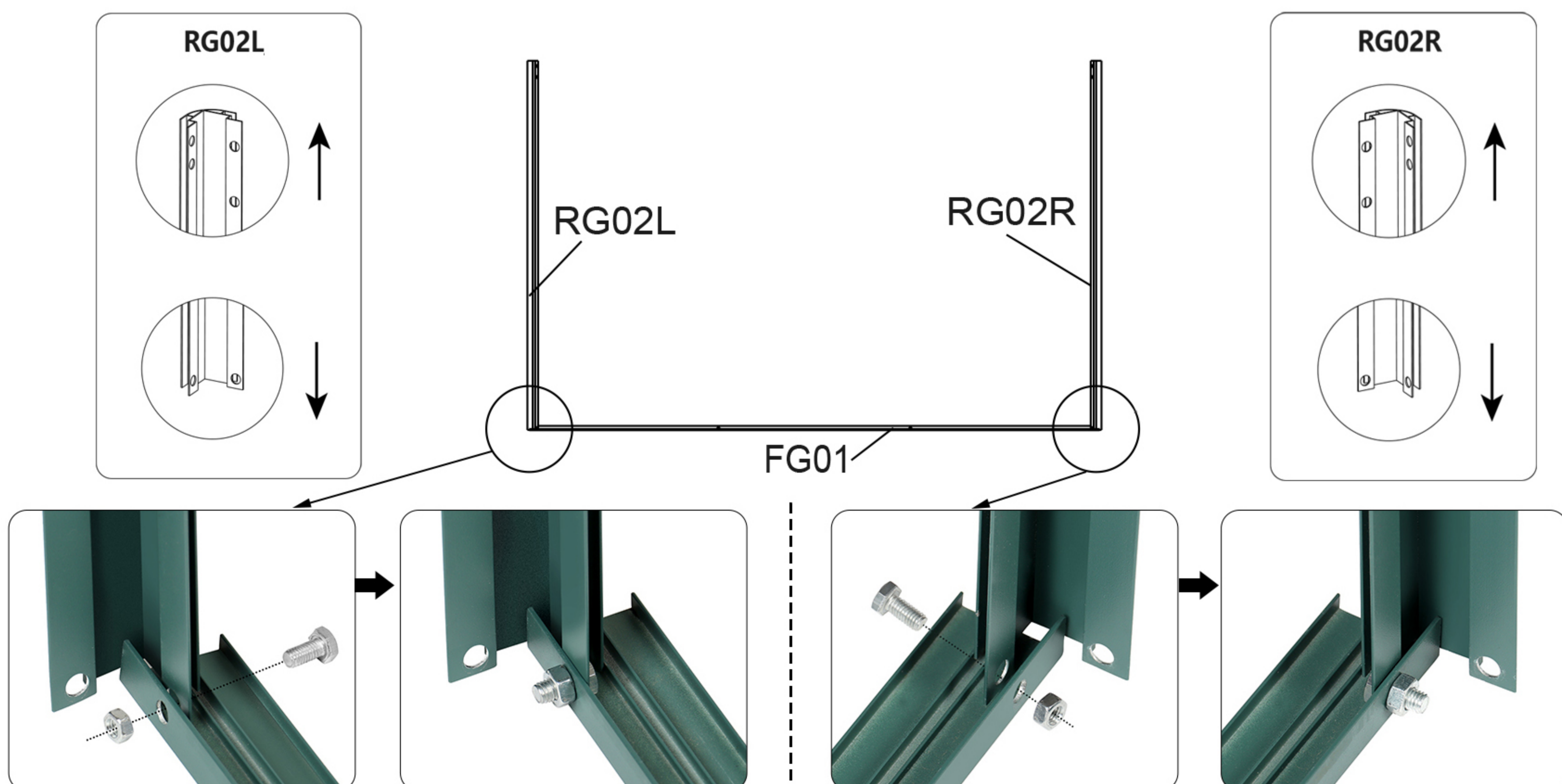

STEP 2

FG02L*1
FG02R*1
RG06*2
LD02*4
LM01*2

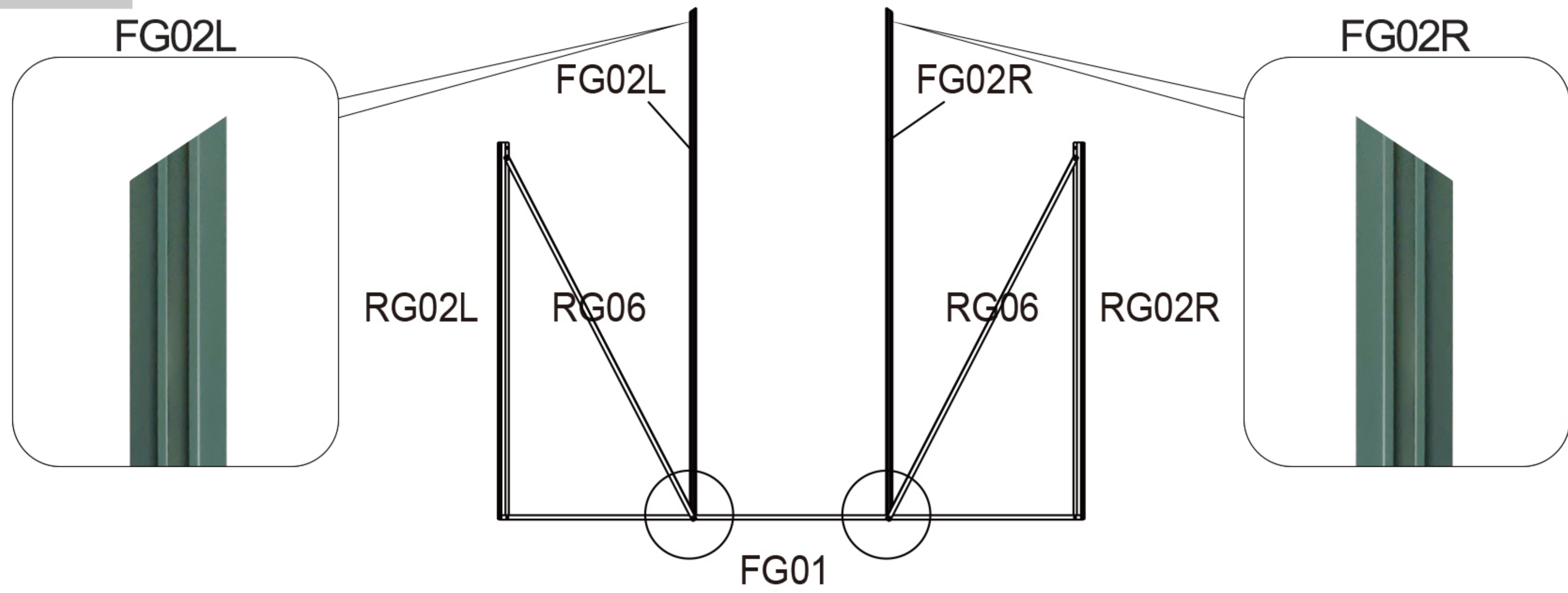

1.The grooves of FG02L and FG02R need to insert 2 bolts LD02 each in advance.Don't screw the nuts.



2.Put FG02L and FG02R into the groove of FG01.

3. Connect FG02R, FG01 RG06 with one of the Pre-inserted bolt LD02, and tighten with a nut.

4.Connect FG02L, FG01 RG06 with one of the Pre-inserted bolt LD02, and tighten with a nut.

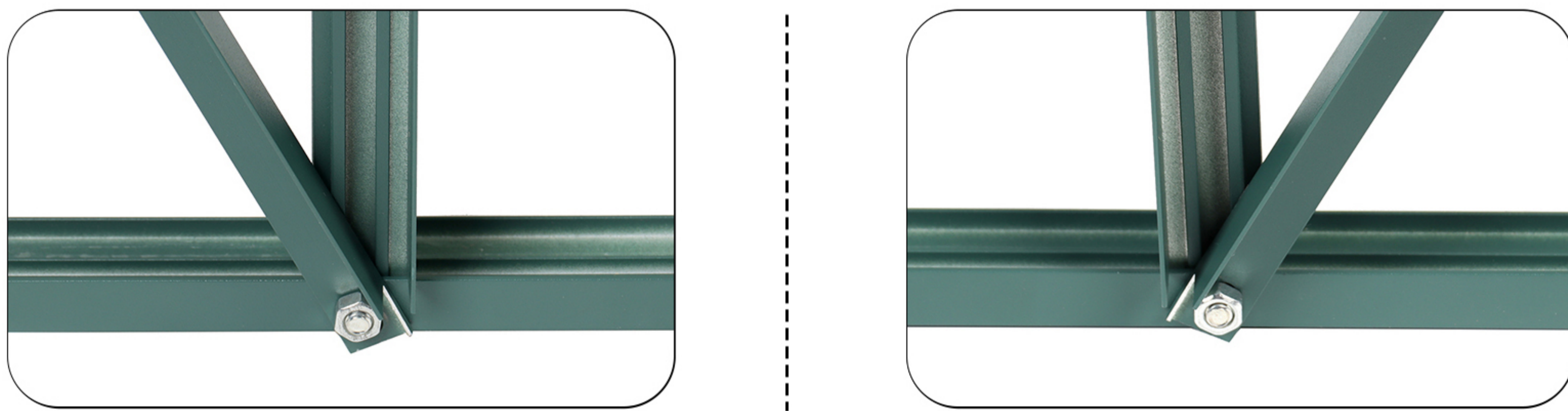

STEP 3

FG04*2
LD02*4
LM01*6

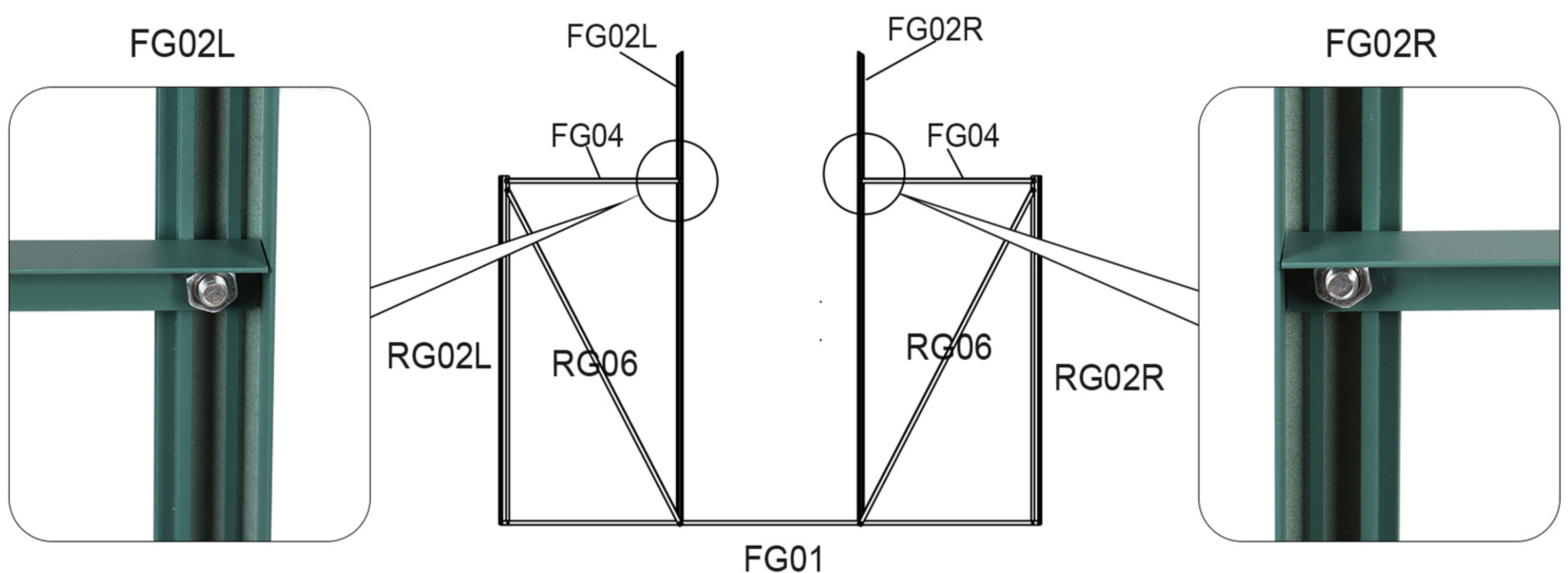

1.Connect FG02R, FG04 with one of the Pre- inserted bolt LD02, and tighten with a nut.
Connect FG02L, FG04 with one of the Pre- inserted bolt LD02, and tighten with a nut.

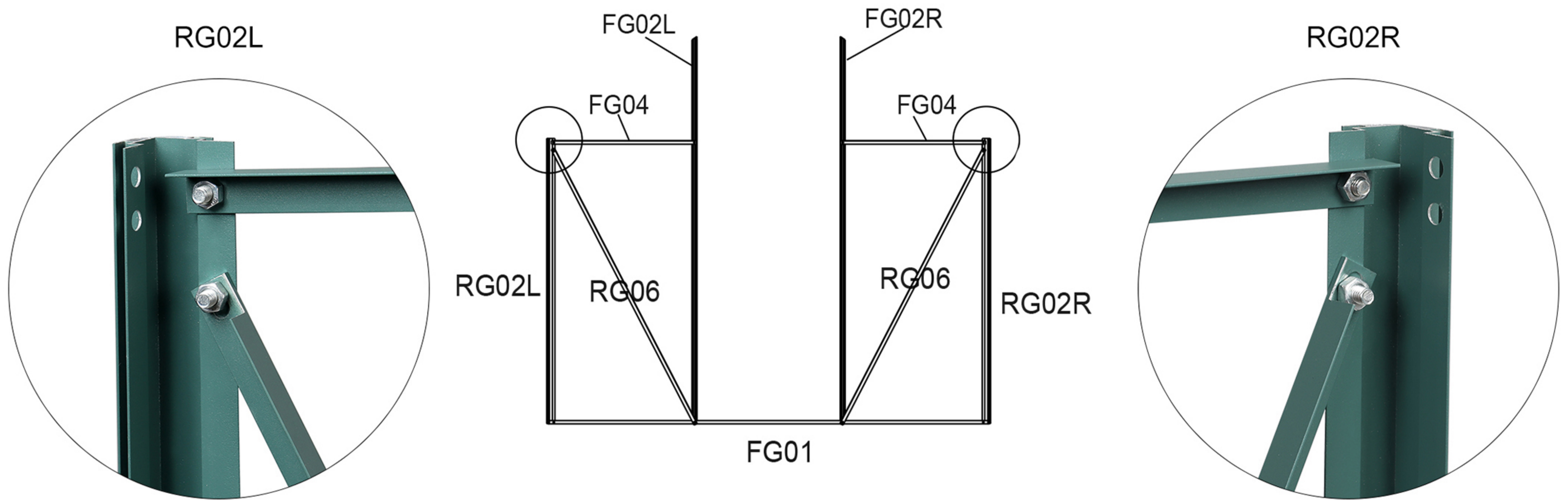

- 2. Connect FG04 with RG02R, FG04 with RG02L by Bolt LD02 and Nut LM01
- 3. Connect RG06 with RG02R, RG06 with RG02L by Bolt LD02 and Nut LM01

STEP 4

P07*2
P04*1
P05*1
P08*2
KT*2

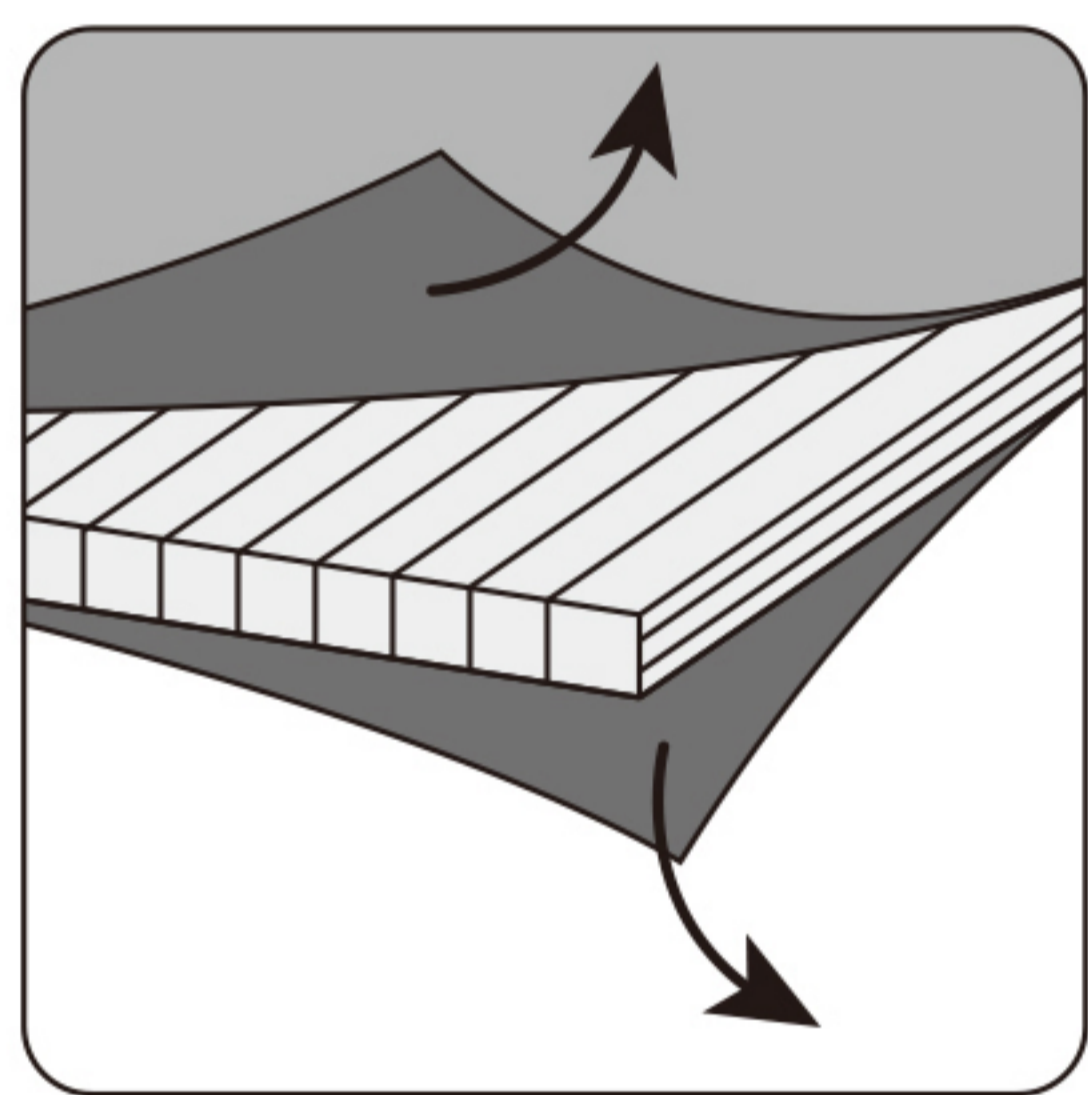

The clear film needs to be exposed to sunlight

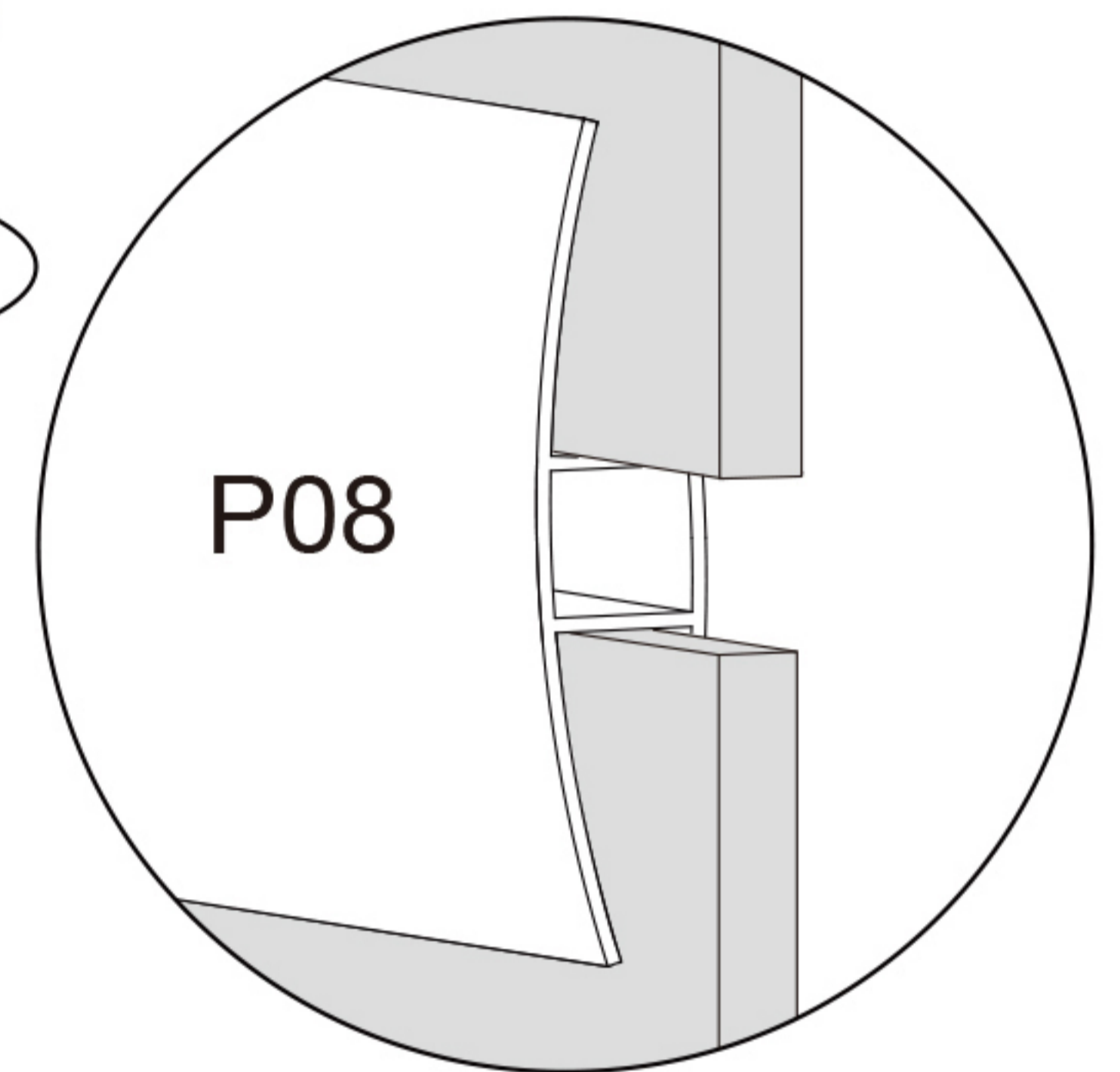
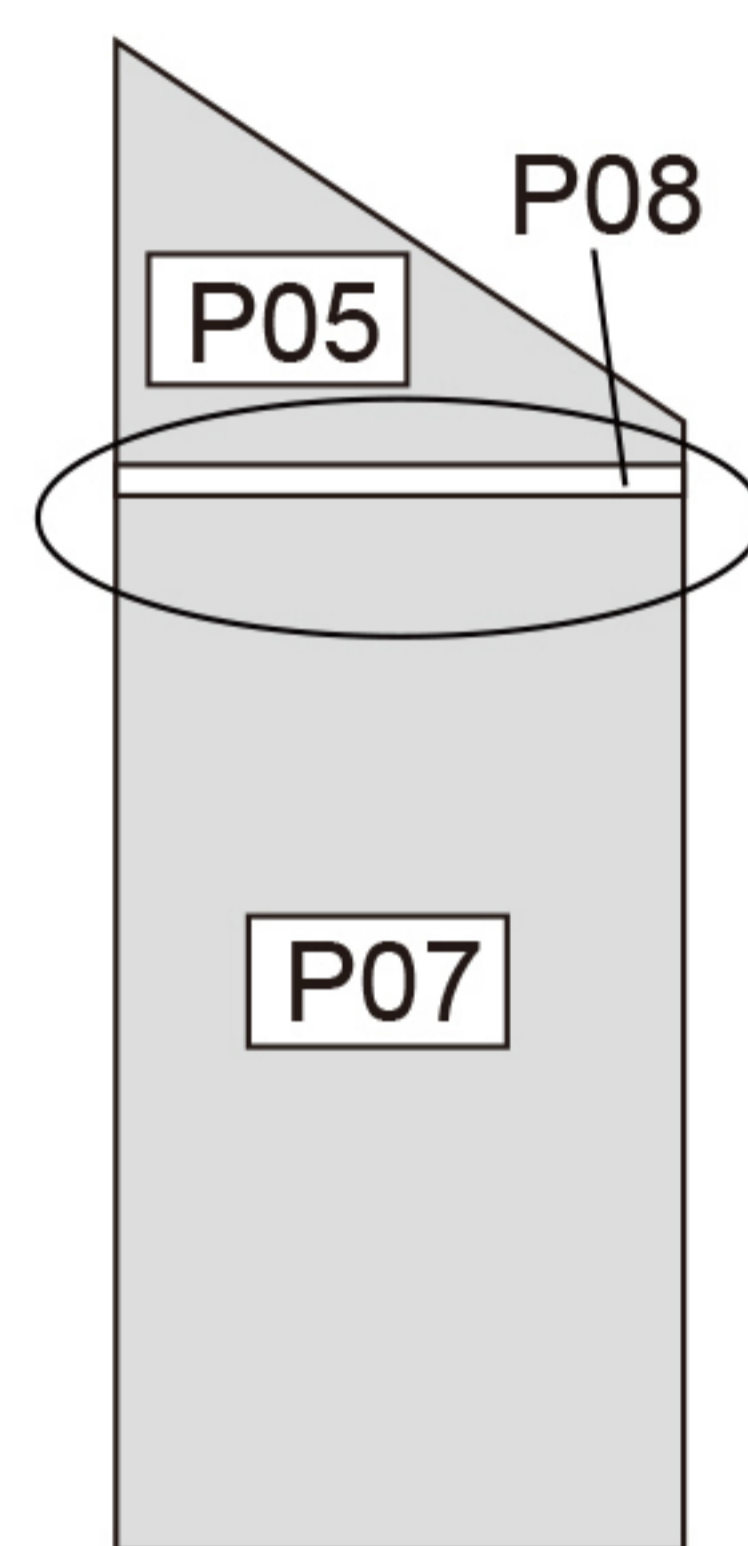
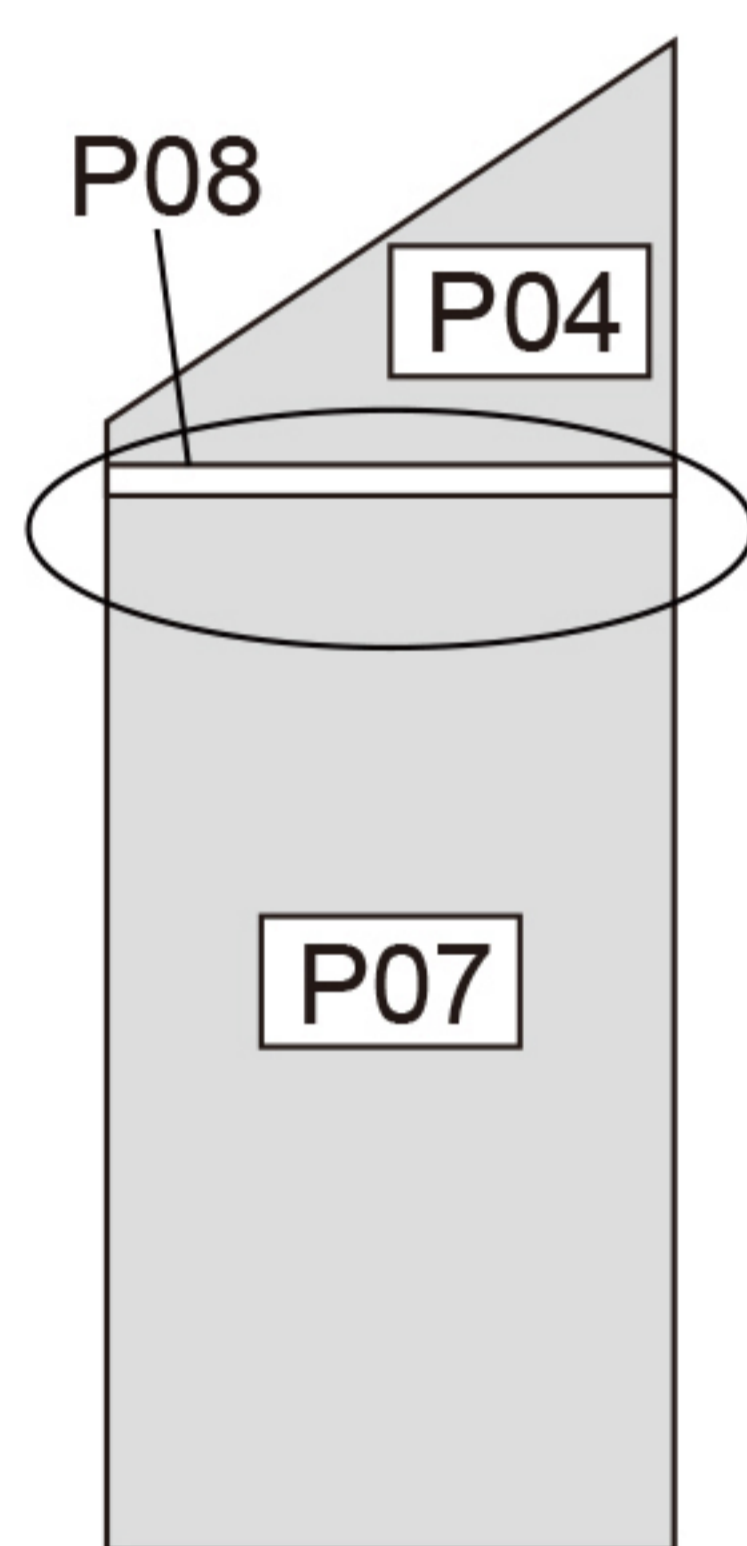

1. Connect panel P07 and panel P04 (P05) with P08.

Note: Need leave a little distance when connected panel

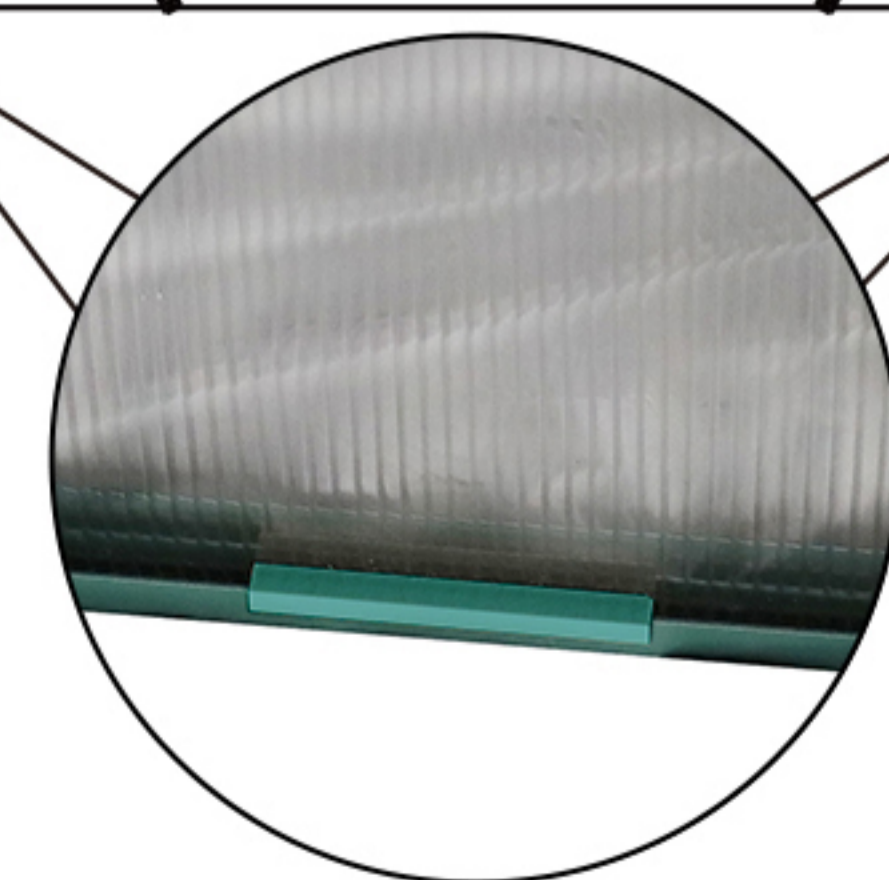
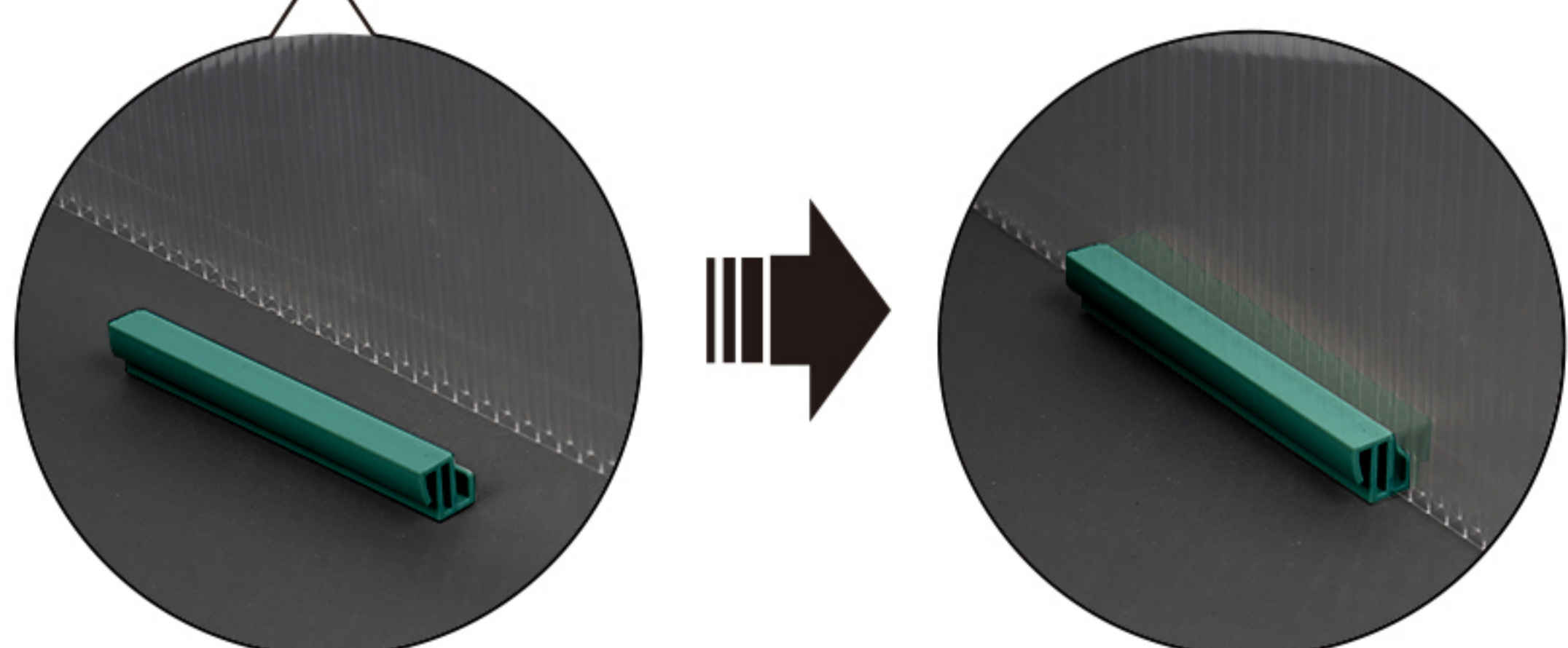
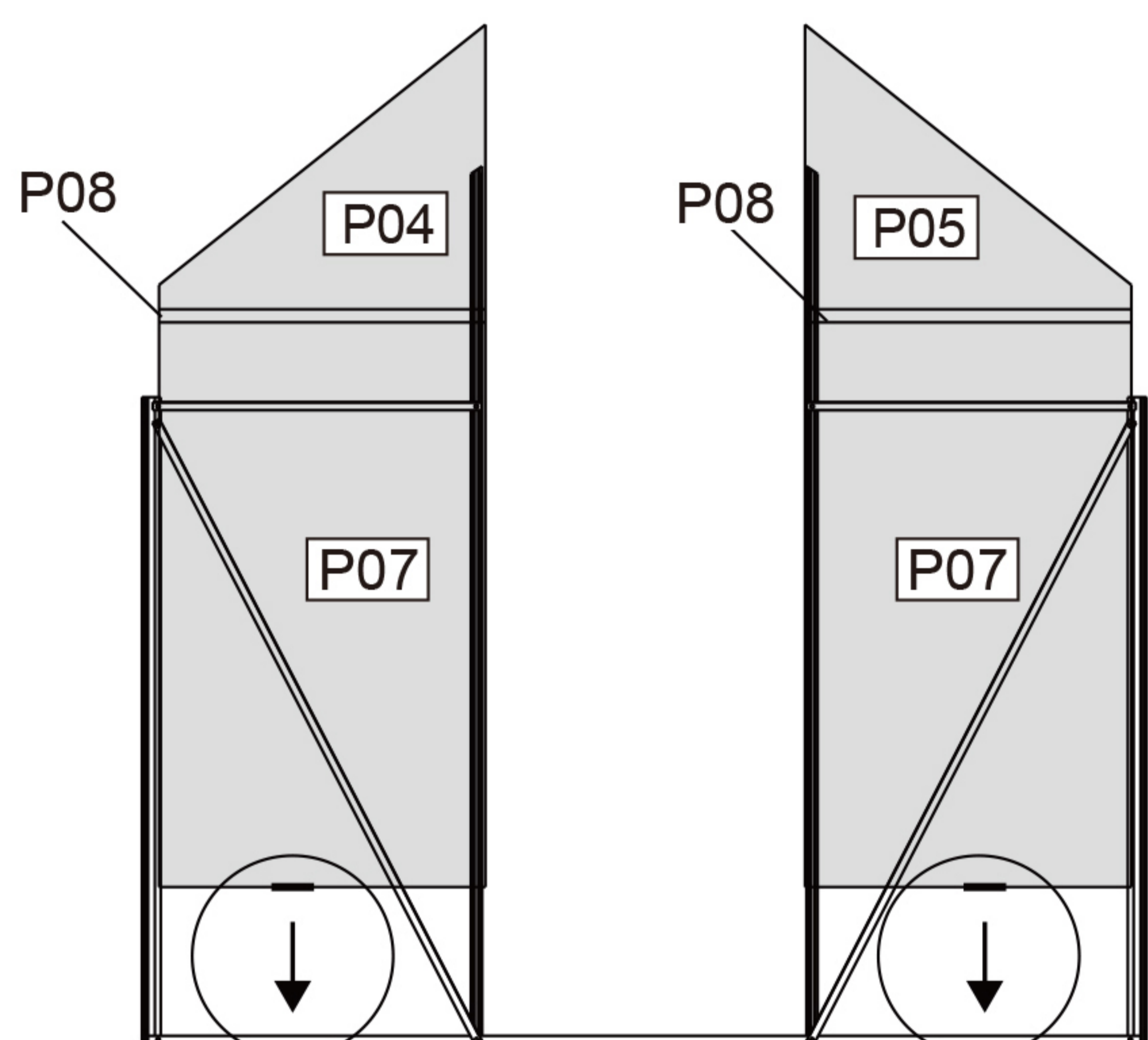
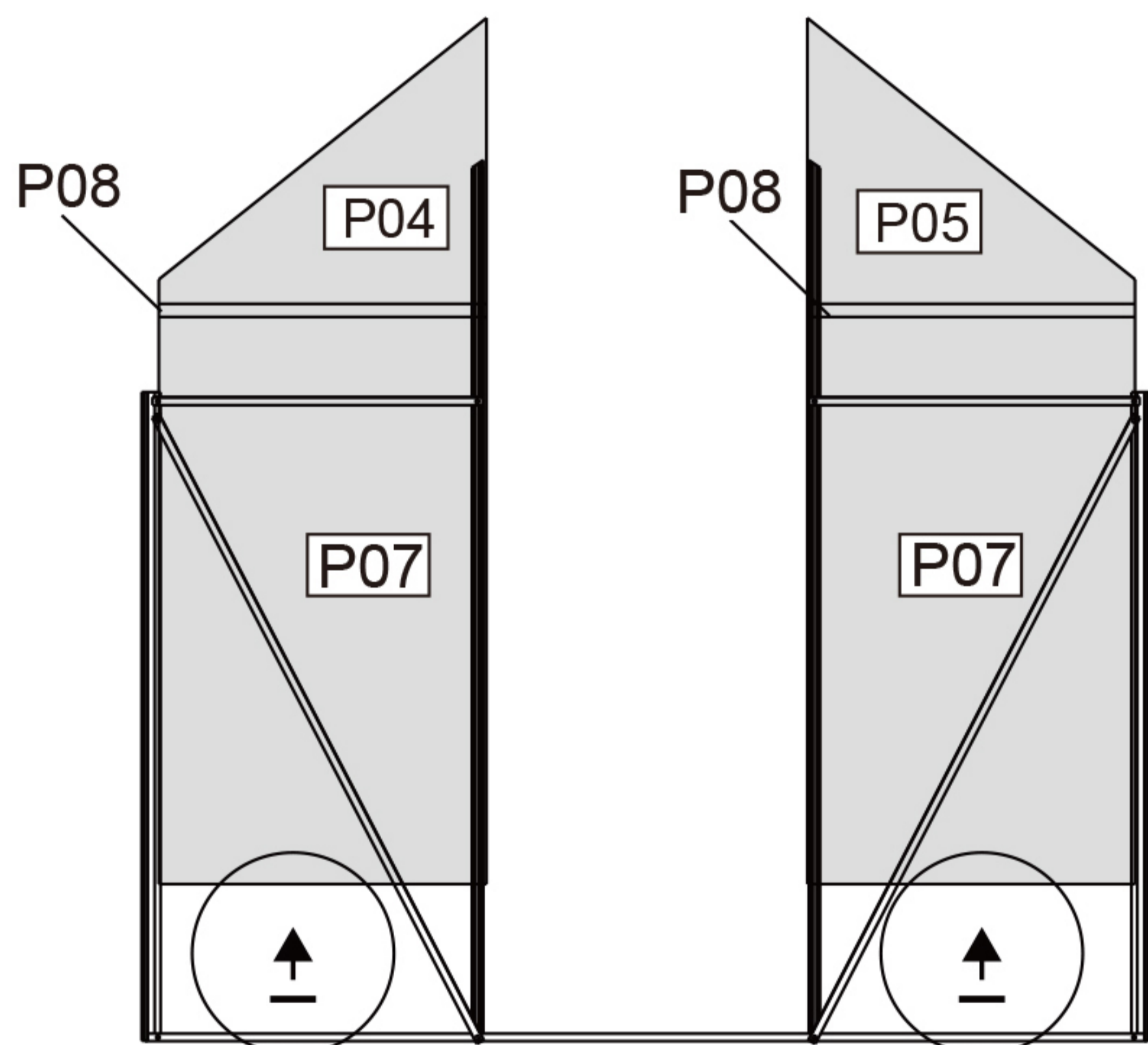

2. Insert the assembled PC panel from above the groove.



Note: In the process of inserting the PC Panel, if it is too loose or too tight, you can loosen the nut at the relevant position to properly adjust the position and spacing of the PC Panel, so that the PC panel can be inserted and installed smoothly.

STEP 5

FG03L*1
FG03R*1
LD02*8
LM01*8

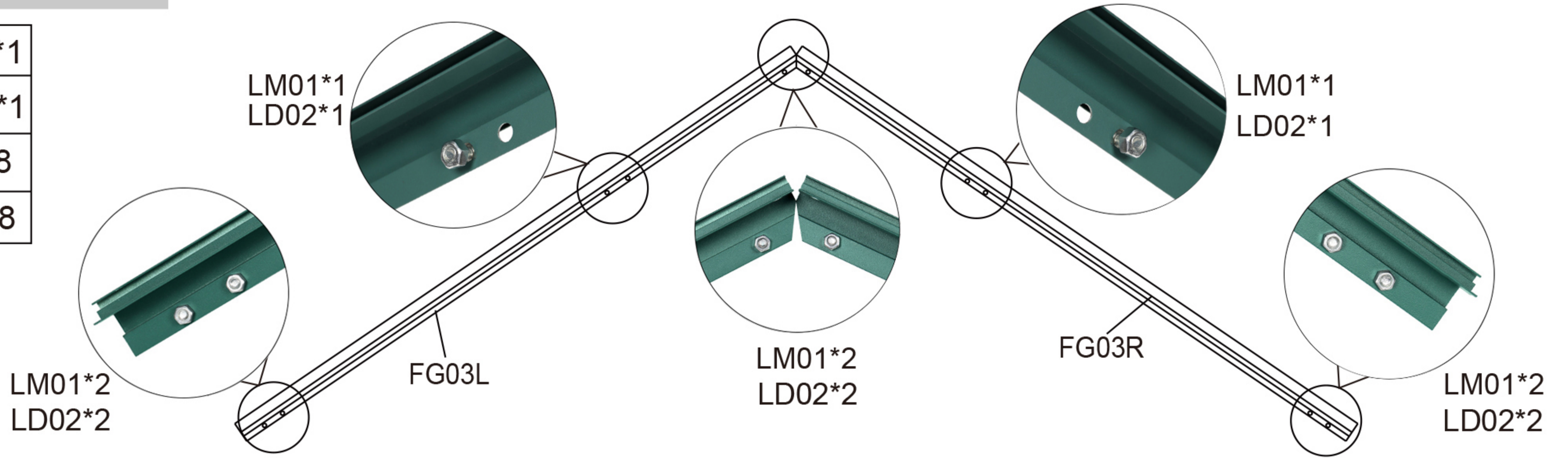

Do not tighten the nut . Only loosely screw it onto the thread .

STEP 6

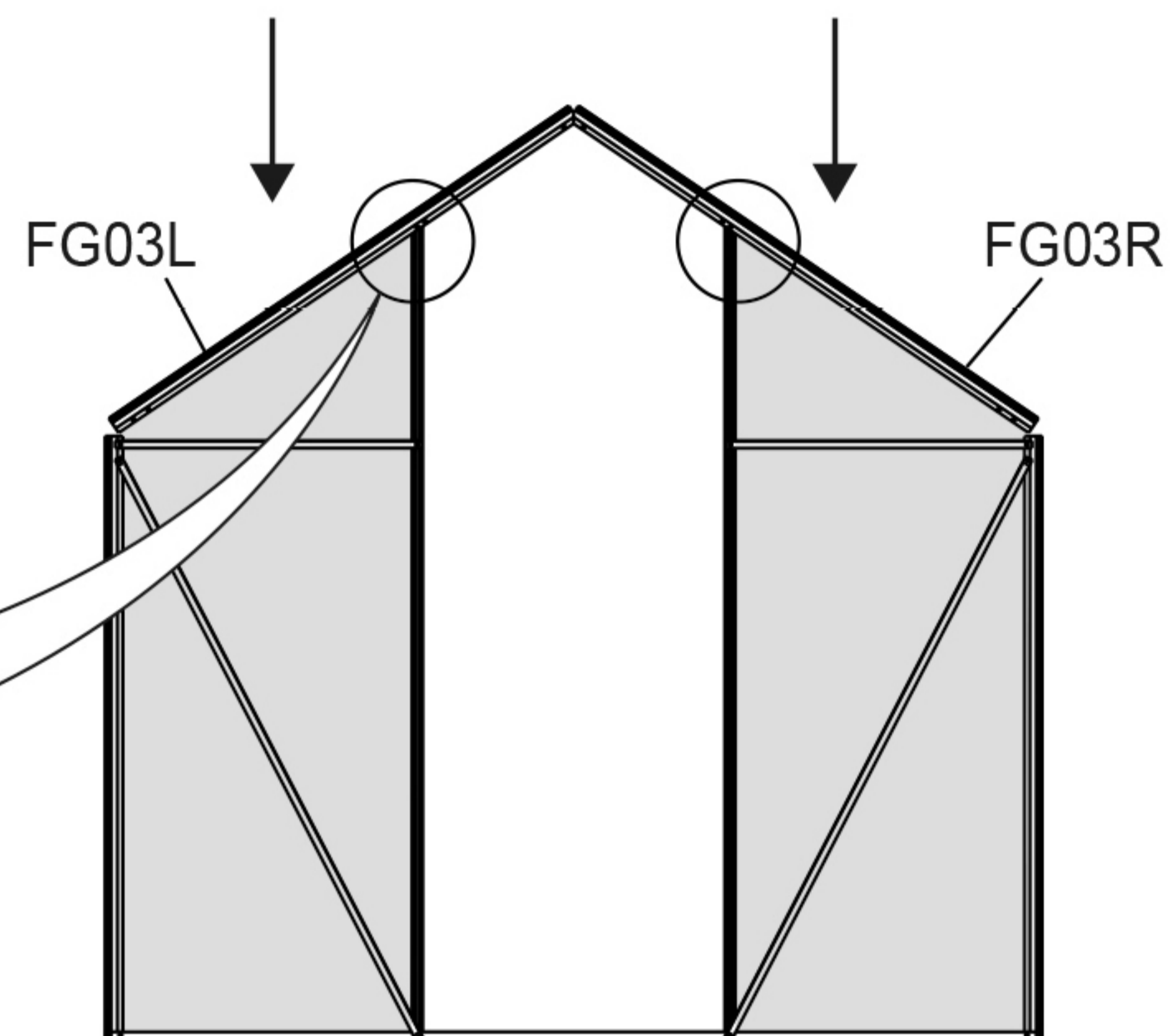
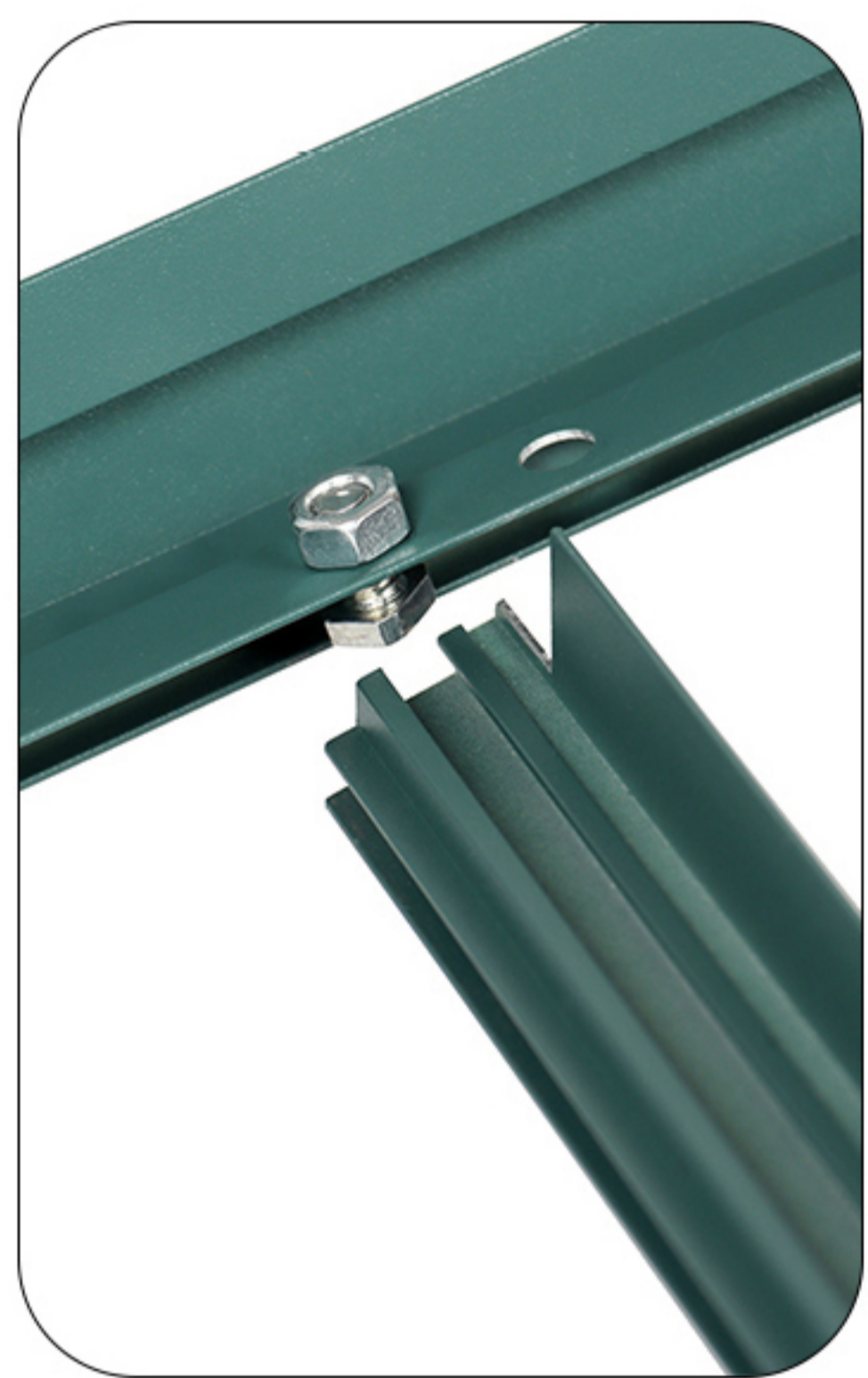

Insert the PC panel into the reserved groove of FG03L and FG03R. Then Press it down into place. The bolt LD02 need to insert into the grooves and fasten the nuts.

STEP 7

BJ04*1
BJ05*2

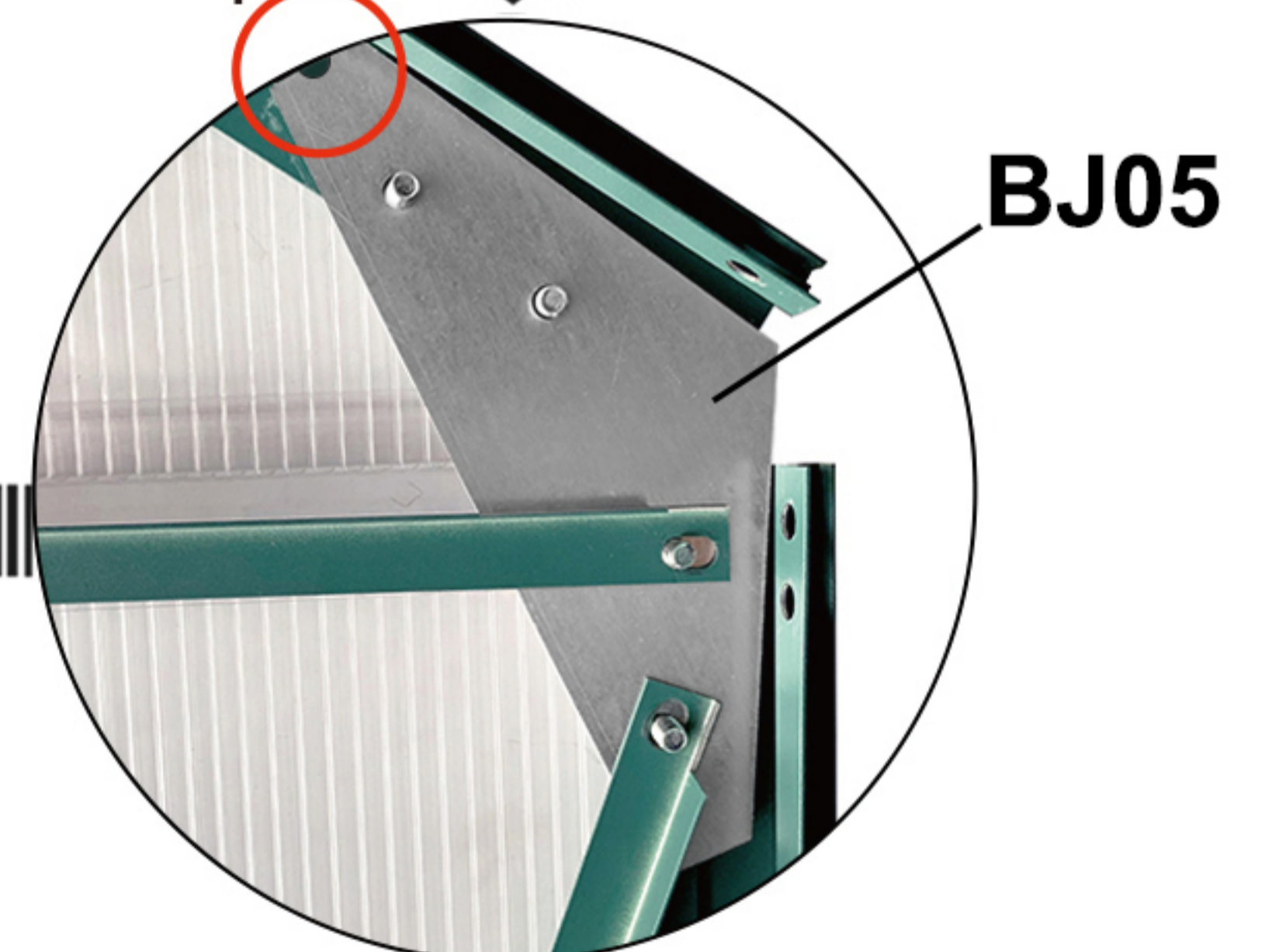
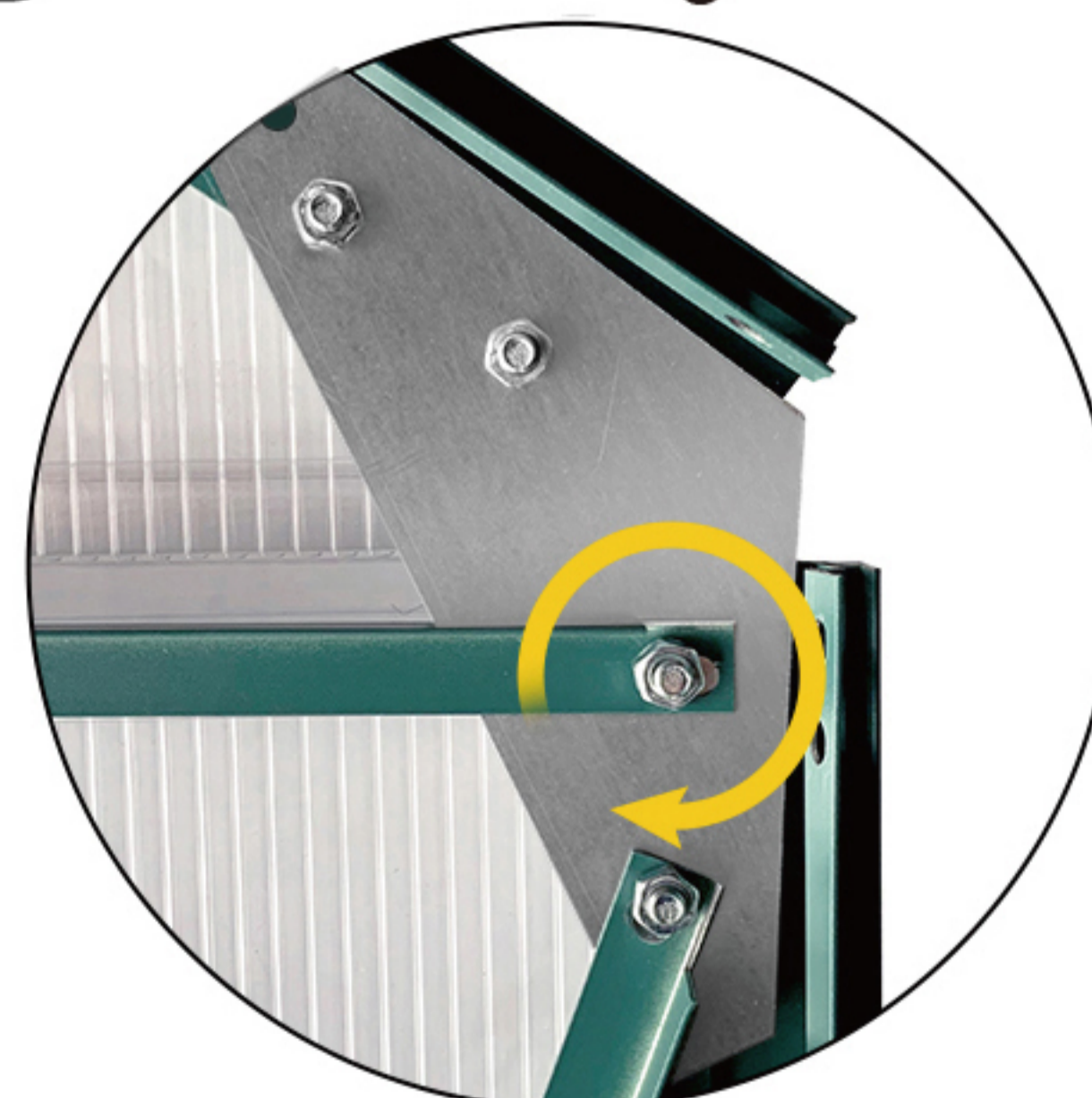
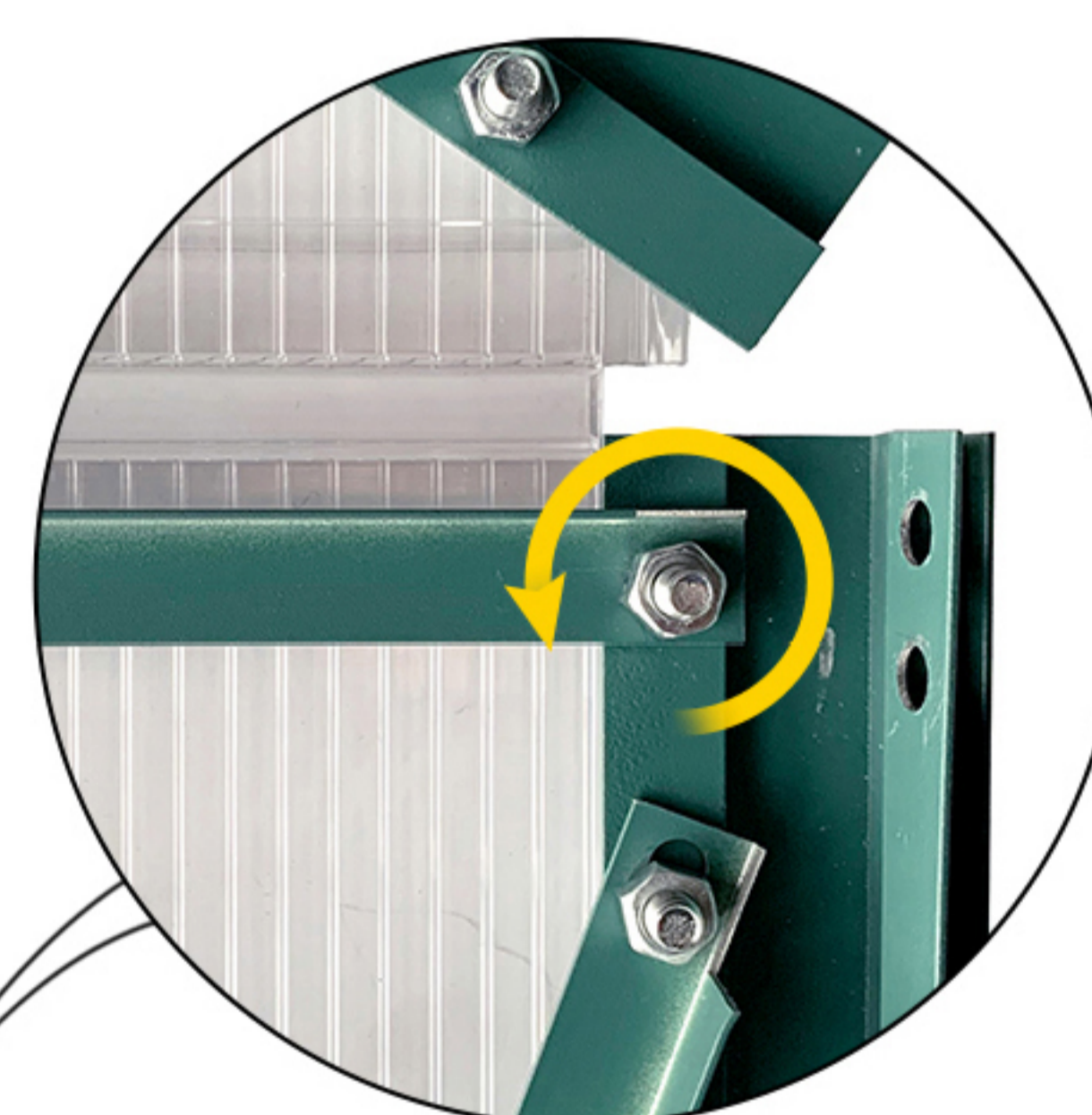
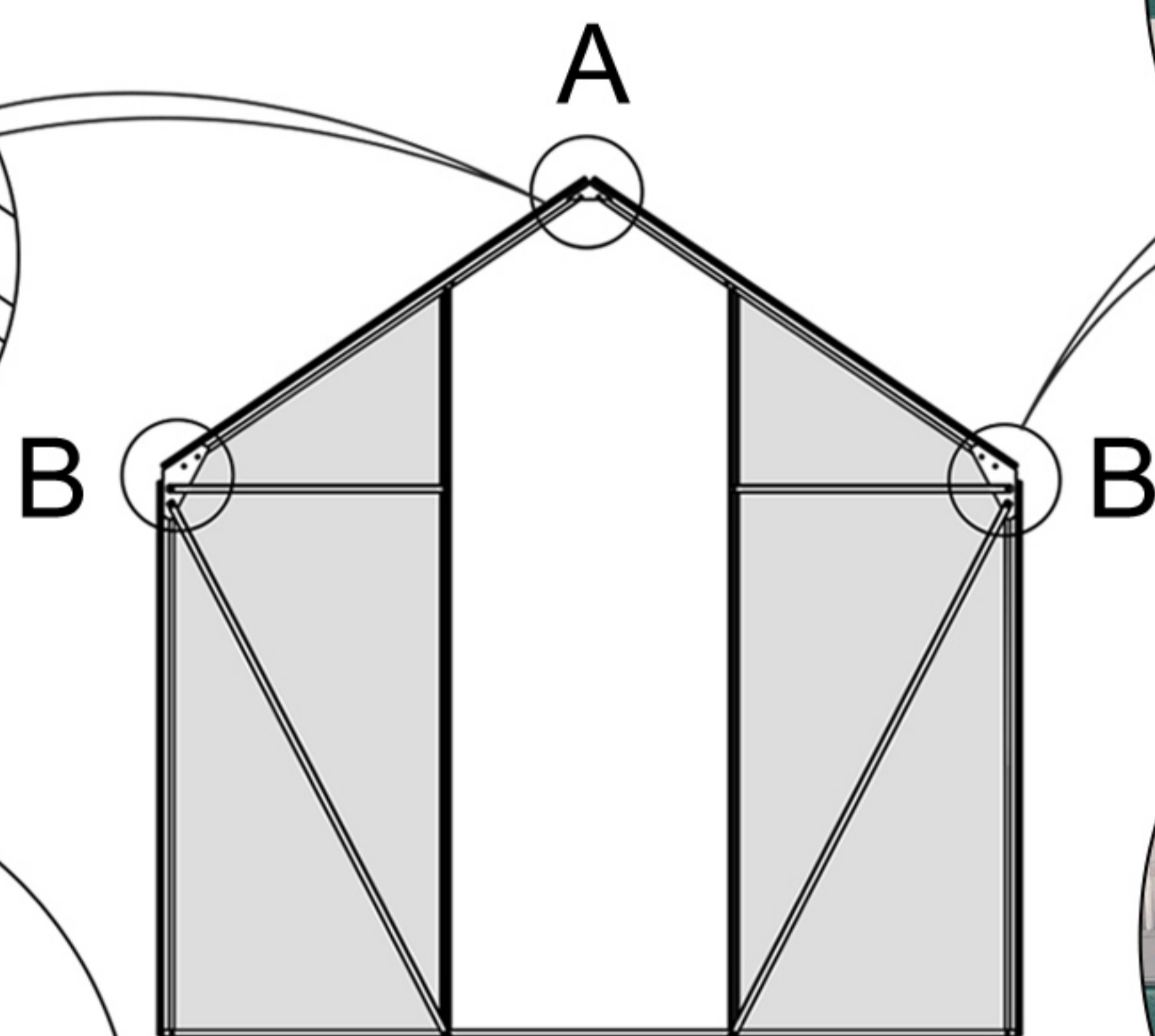
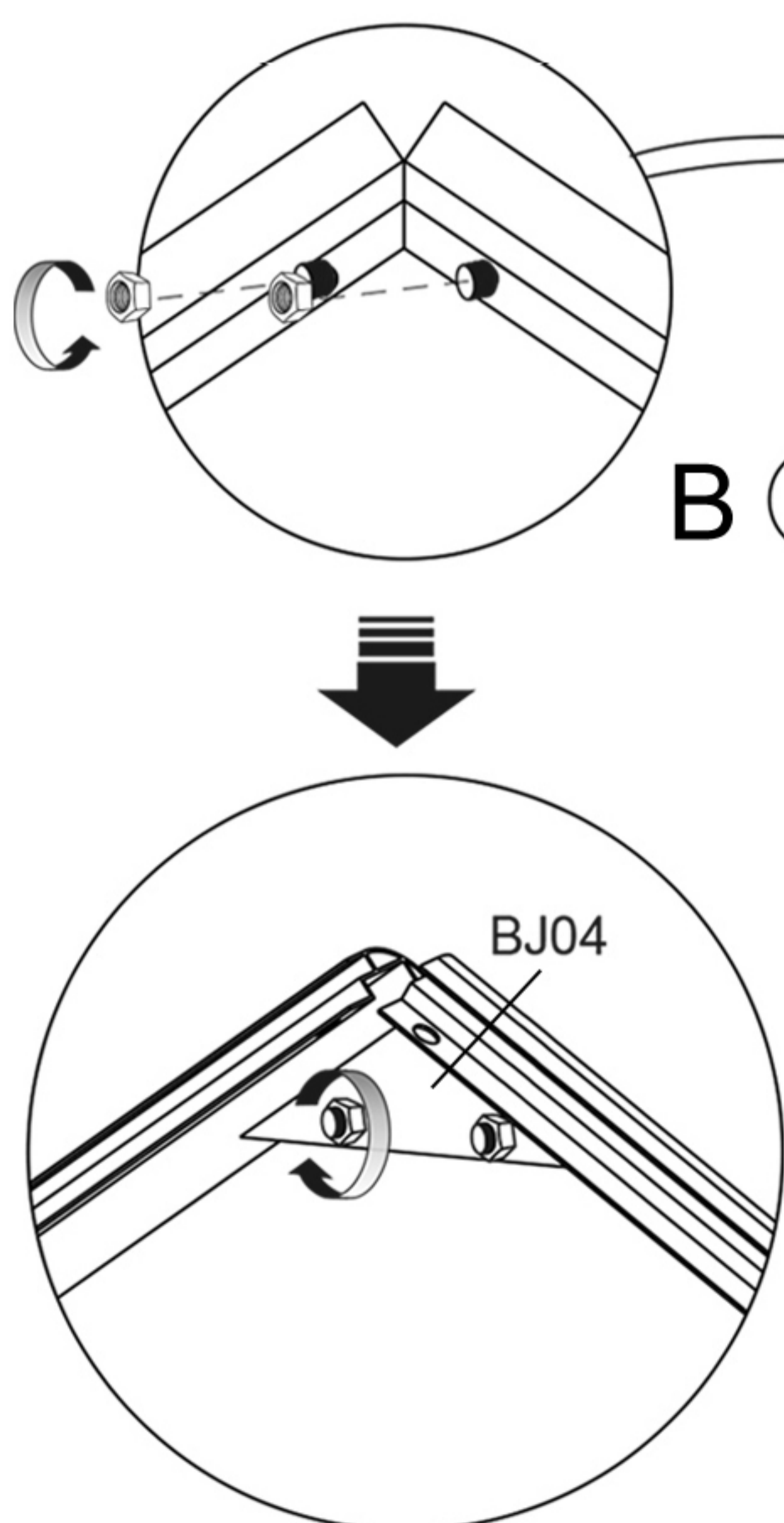

1. Loosen the nuts LM01 in position marked A, install the connecting piece BJ04 and tighten the nut LM01.
2. Loosen the nuts LM01 in position marked B, install the connecting piece BJ05 and tighten the nut LM01.

STEP 8

FG05*1

LD02*2

LM01*2

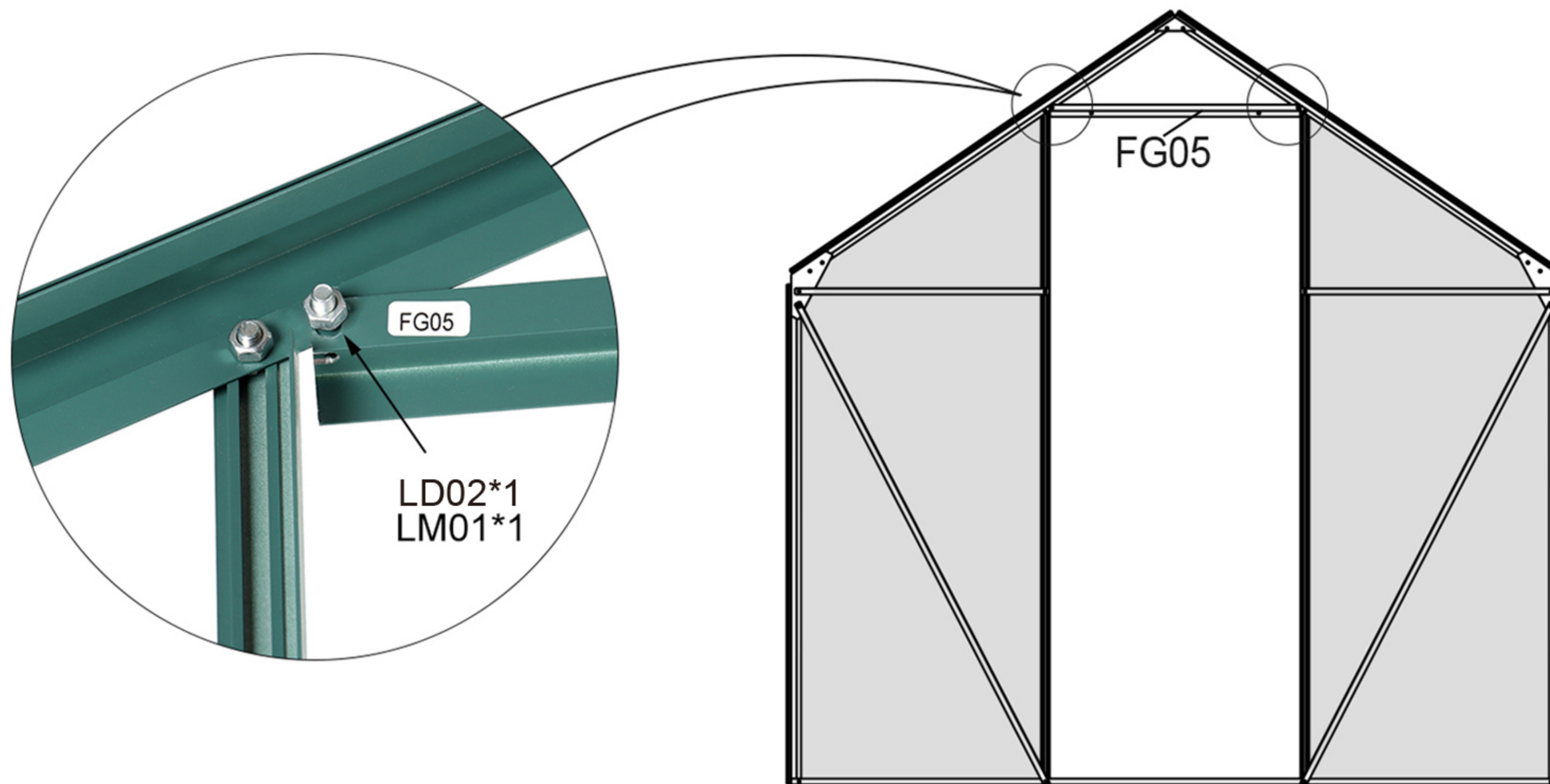

Install FG05

Do not tighten the nut . Only loosely screw it onto the thread .

STEP 9

P01*1







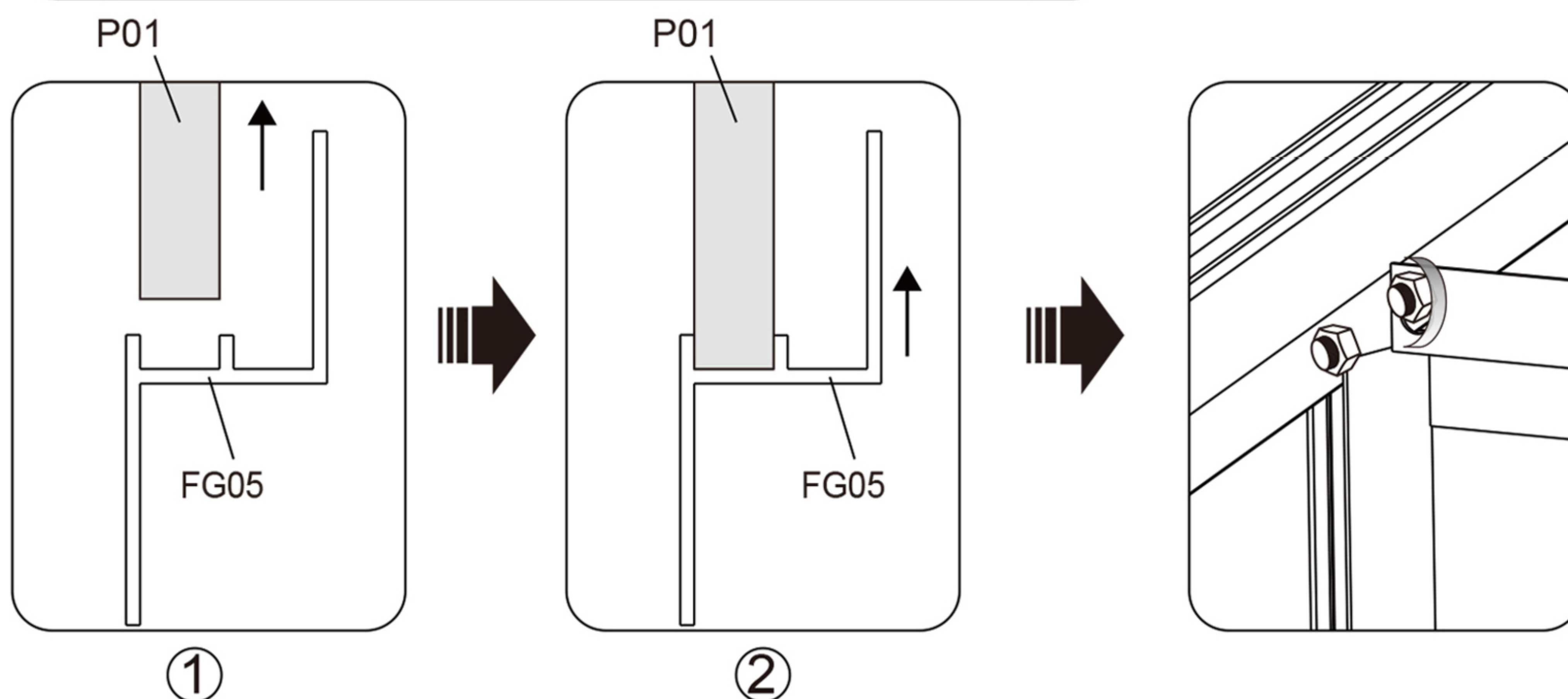
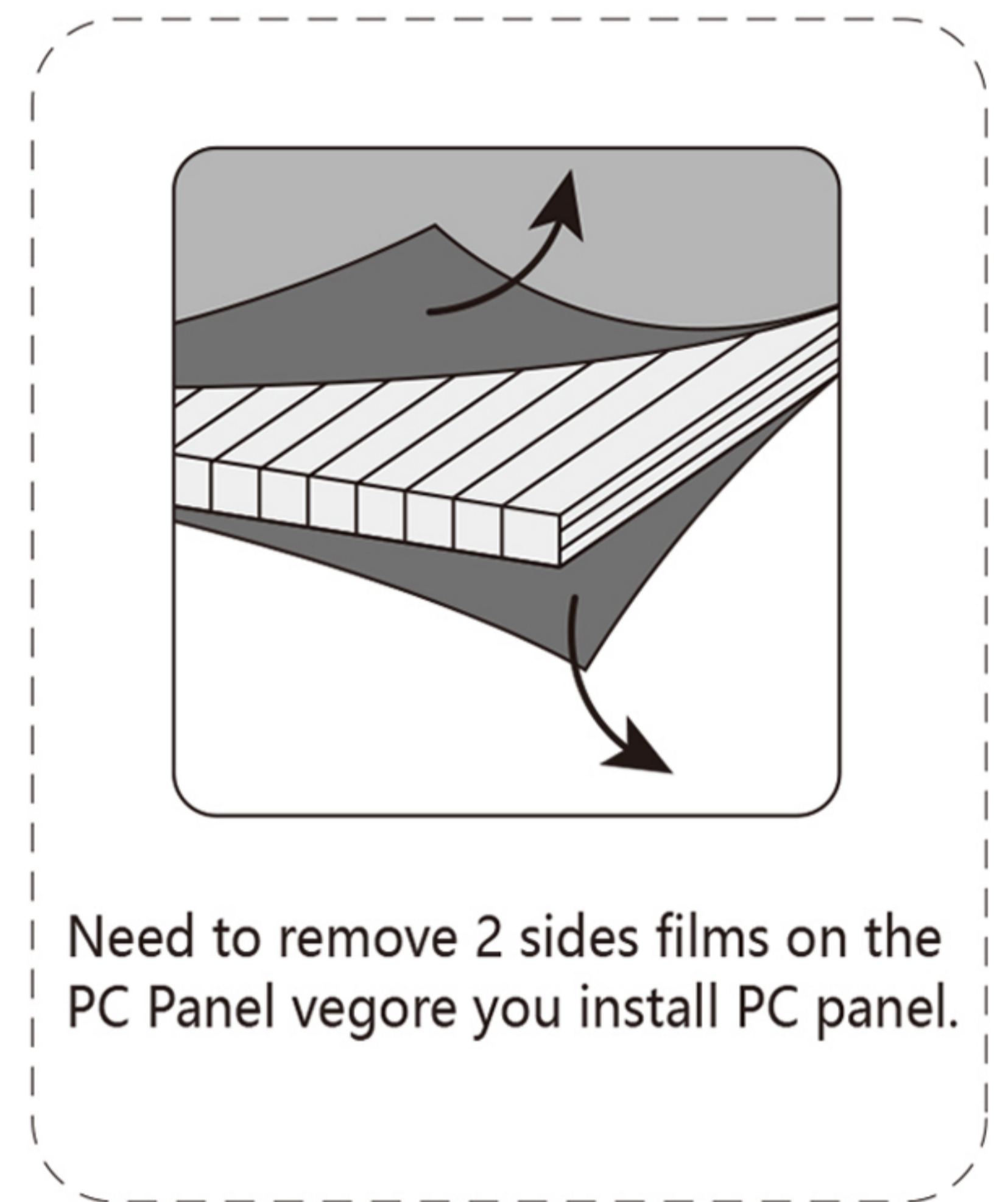
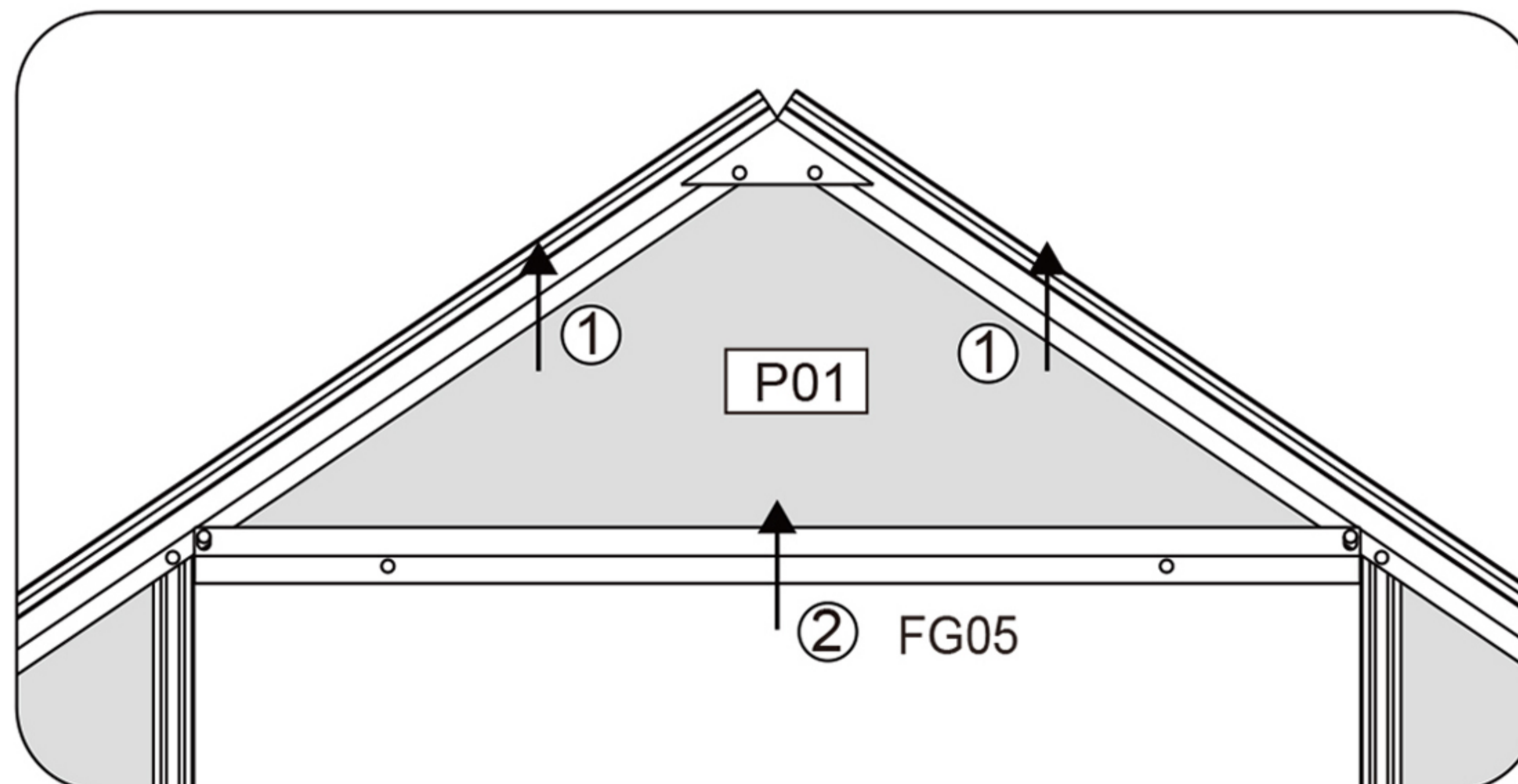



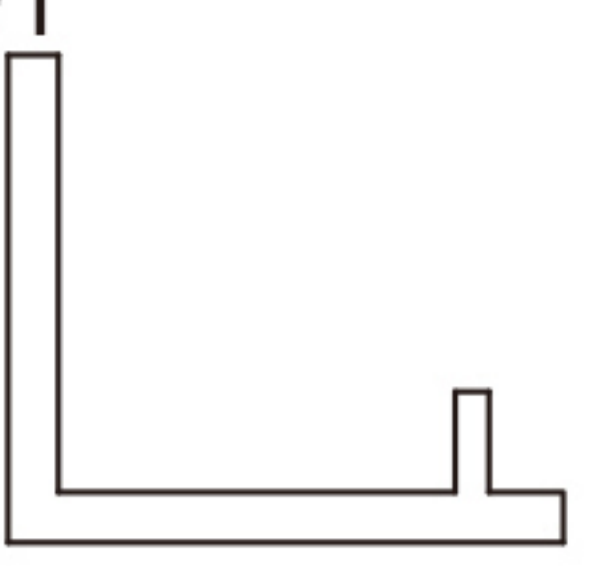

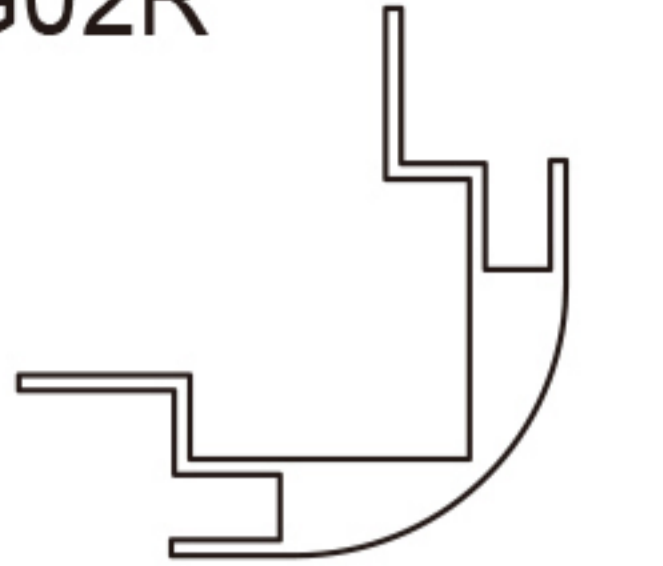
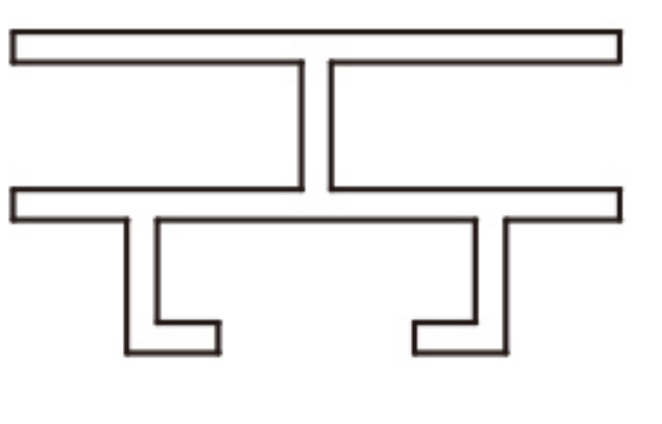
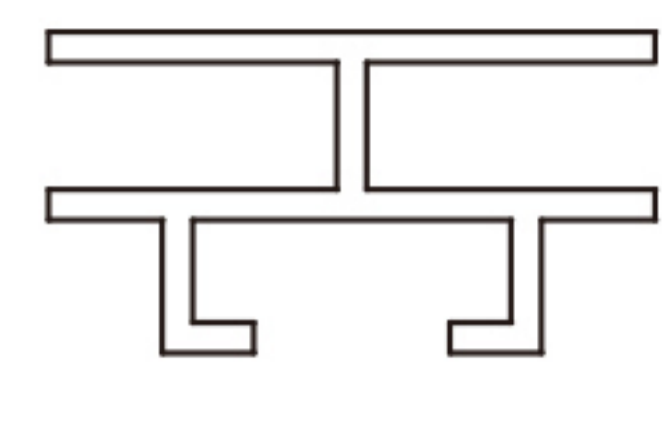

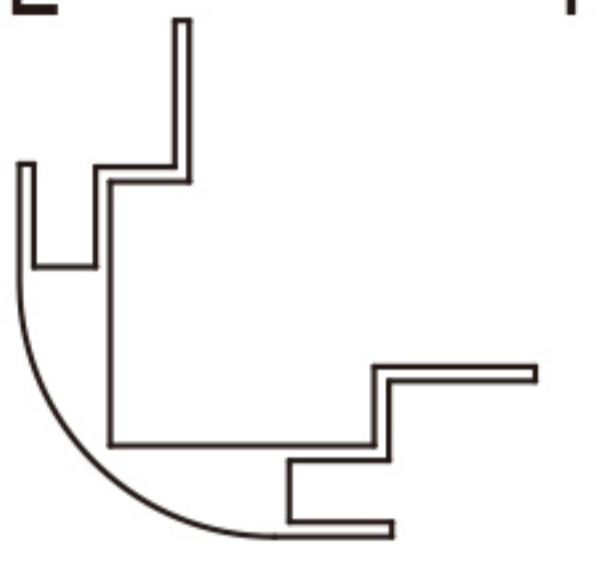
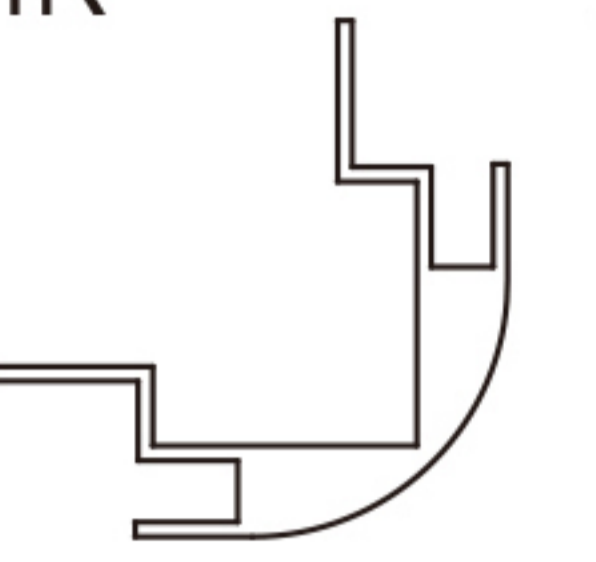
Insert PC Panel P01 and tighten the nut.

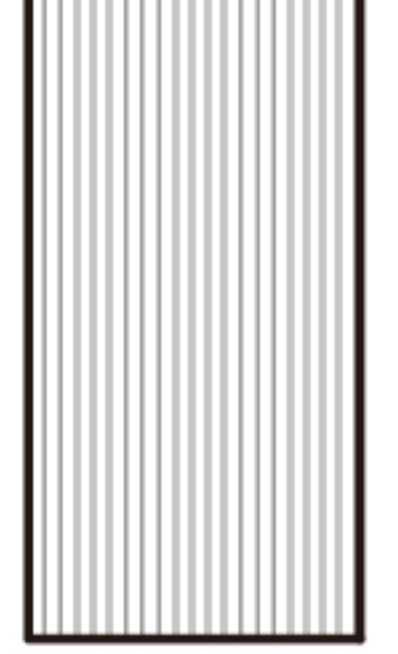
Tips: You can first snap two sides of the PC panel labeled 1 up into the notch, and then snap this side of the PC panel labeled 2 into the notch of the FG05. Finally, push the FG05 upward to fix the PC panel and then tighten the nut.

For detailed steps, please see the installation video.

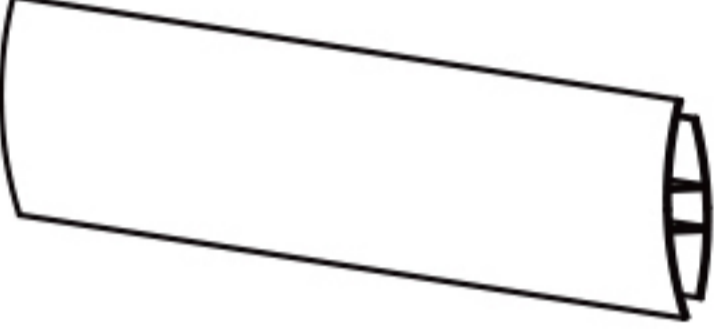

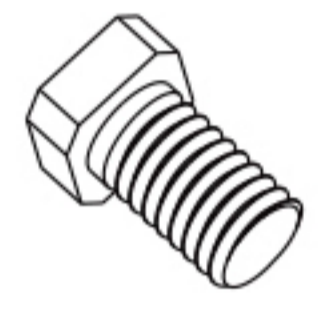
Rear Gable Assembly

RG01 	1PC	RG02L 	1PC	RG02R 	1PC	RG03L 	1PC	RG03R 	1PC
RG05 	1PC	RG06 	2PCS	RG04L 	1PC	RG04R 	1PC	BJ04 	1PC
BJ05 	2PCS	P07 	3PCS	P02 	1PC	P04 	1PC	P05 	1PC
		46.4"x23.8"x0.16"		25.7"x23.8"x0.16"		17.2"x23.6"x0.16"		17.2"x23.6"x0.16"	
P08 	3PCS	KT 	3PCS	LD02 	14PCS	LD01 	4PCS	LM01 	18PCS
				M6x12		M6x18		M6	

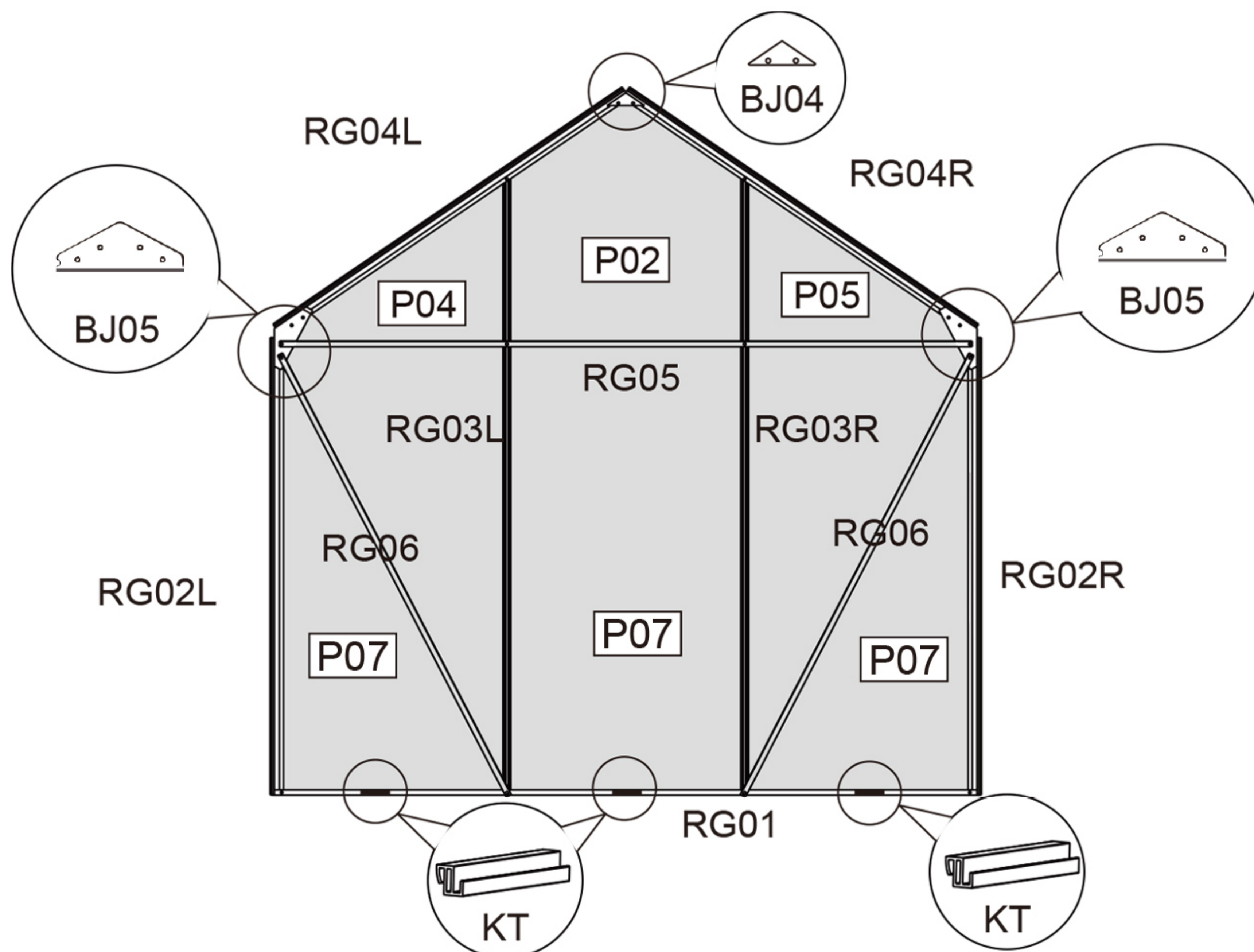

STEP 1

Connect RG02L, RG01 and RG02R with Nut LM01 and Bolt LD02.

RG02L*1
RG02R*1
RG01*1
LD02*2
LM01*2

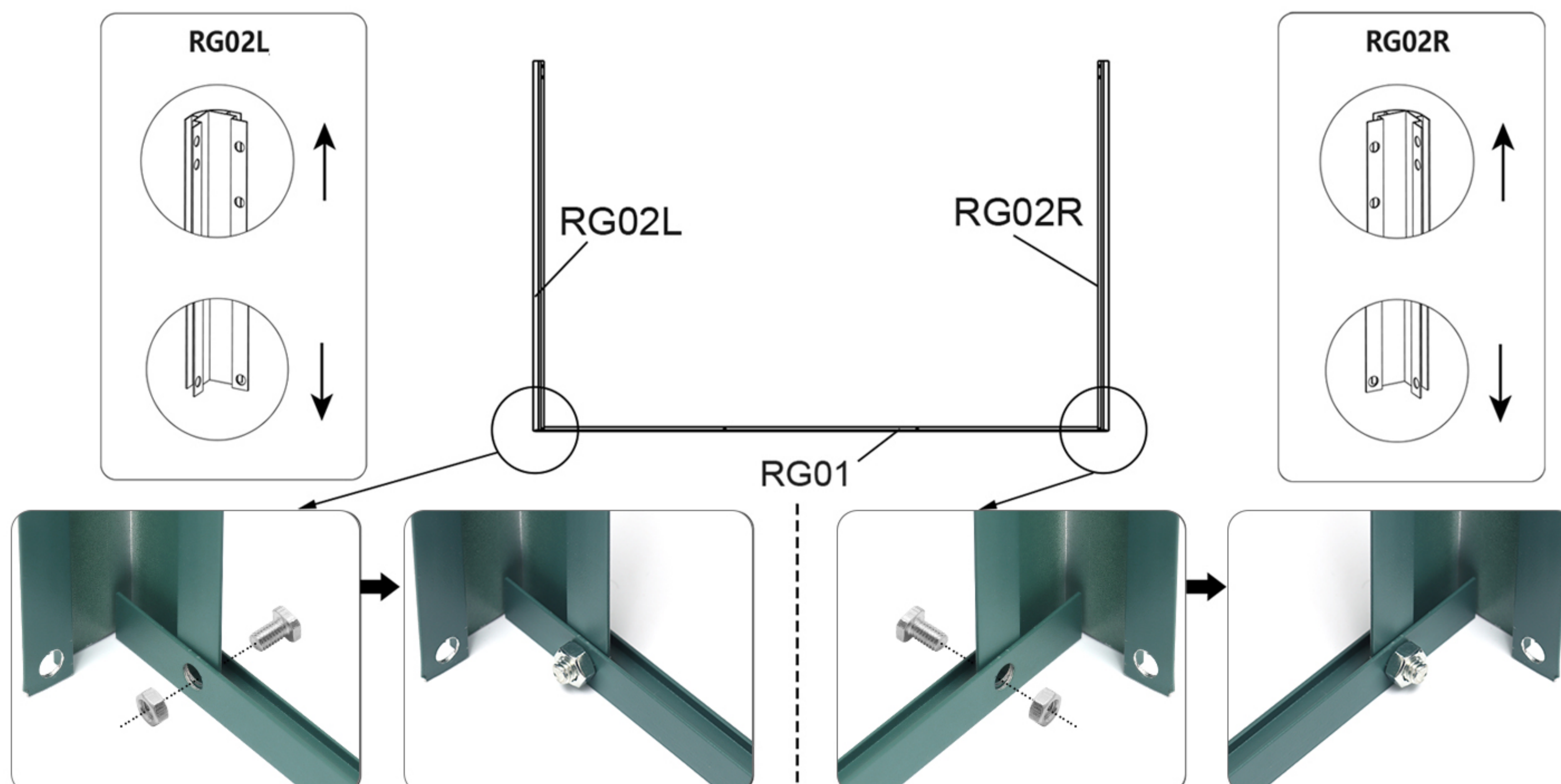

STEP 2

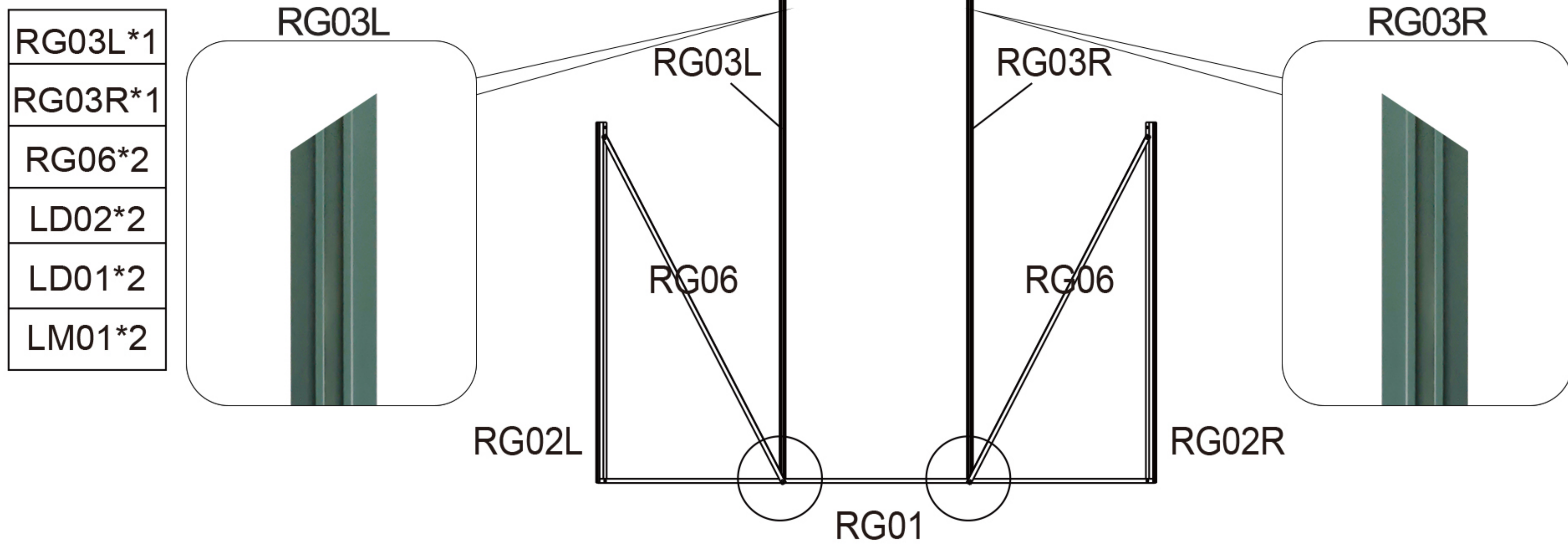

1. The grooves of RG03L and RG03R need to insert 2 bolts LD01 LD02 each in advance. LD01 is prepared for step 3. Don't screw the nuts.

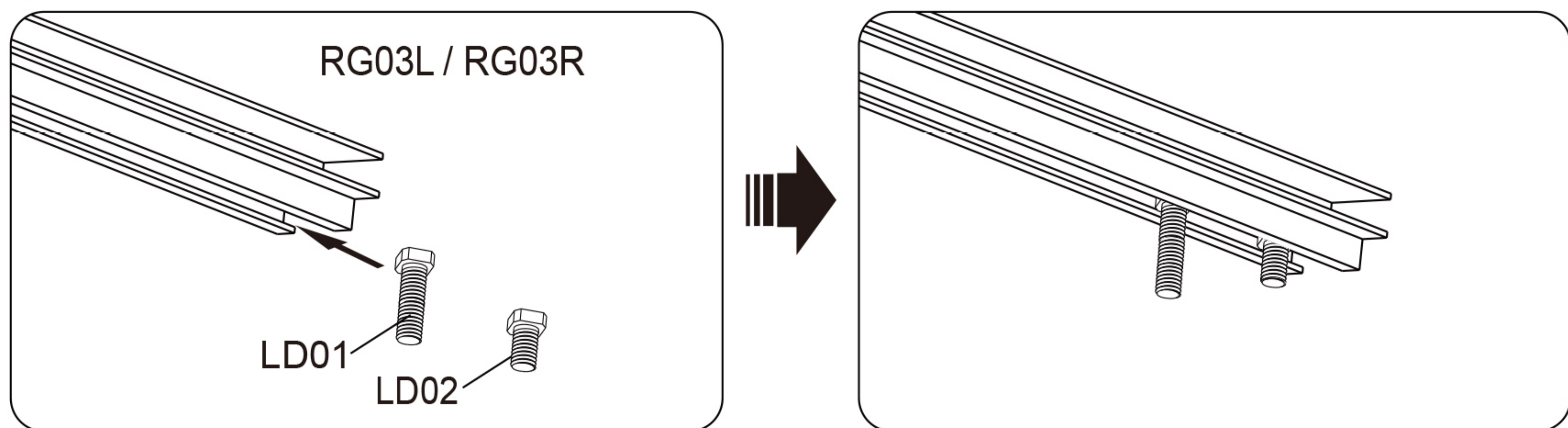

2. Put RG03L and RG03R into the groove of RG01.

3. Connect RG03R, RG01 RG06 with one of the Pre- inserted bolt LD02, and tighten with a nut.

4. Connect RG03L, RG01 RG06 with one of the Pre- inserted bolt LD02, and tighten with a nut.

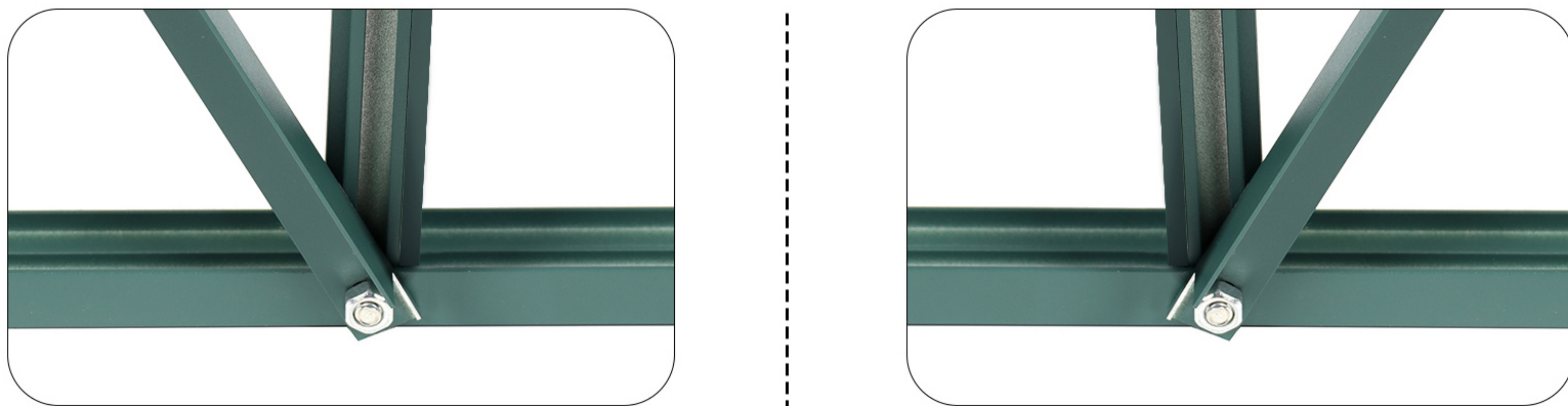

STEP 3

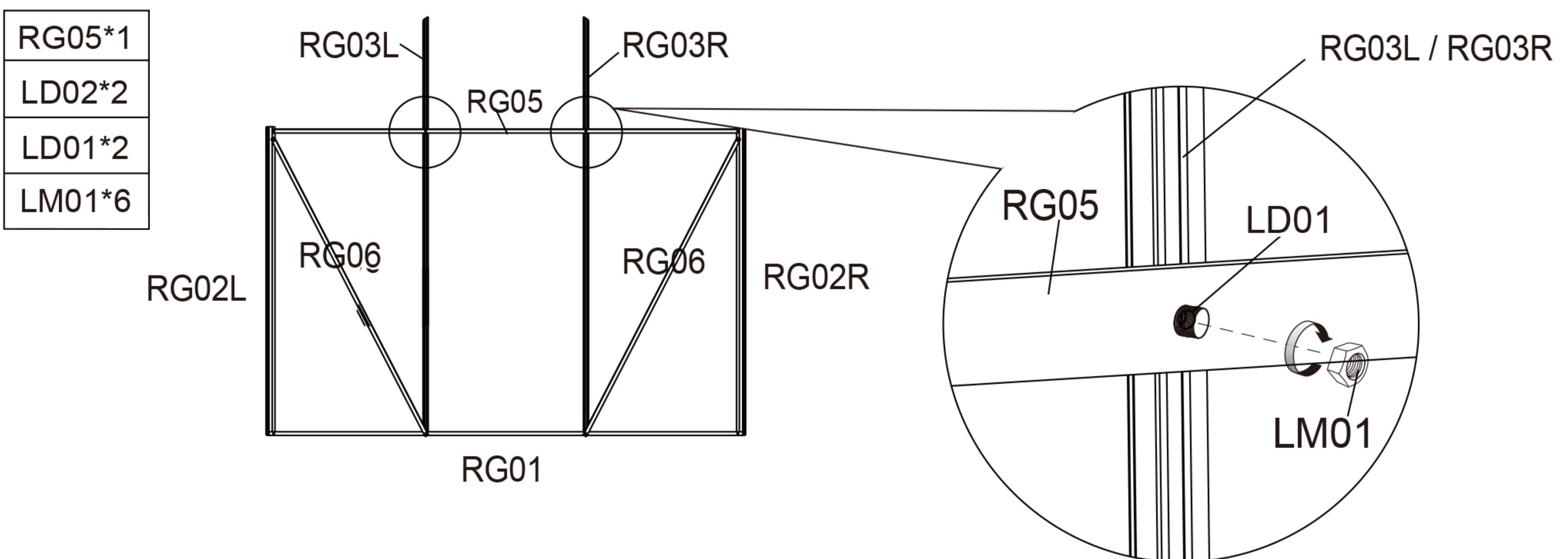

1. Connect RG03R, RG05 with one of the Pre- inserted bolt LD01, and tighten with a nut. Connect RG03L, RG05 with one of the Pre- inserted bolt LD01, and tighten with a nut.

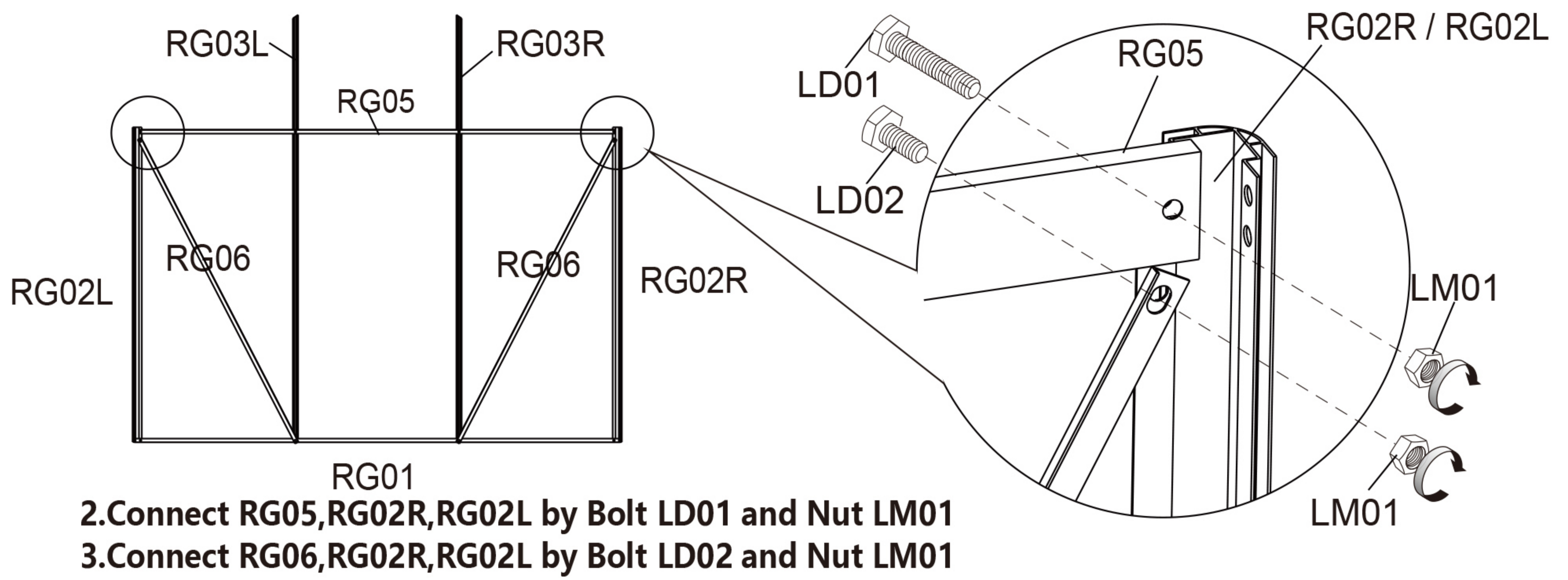

2. Connect RG05, RG02R, RG02L by Bolt LD01 and Nut LM01
3. Connect RG06, RG02R, RG02L by Bolt LD02 and Nut LM01

STEP 4

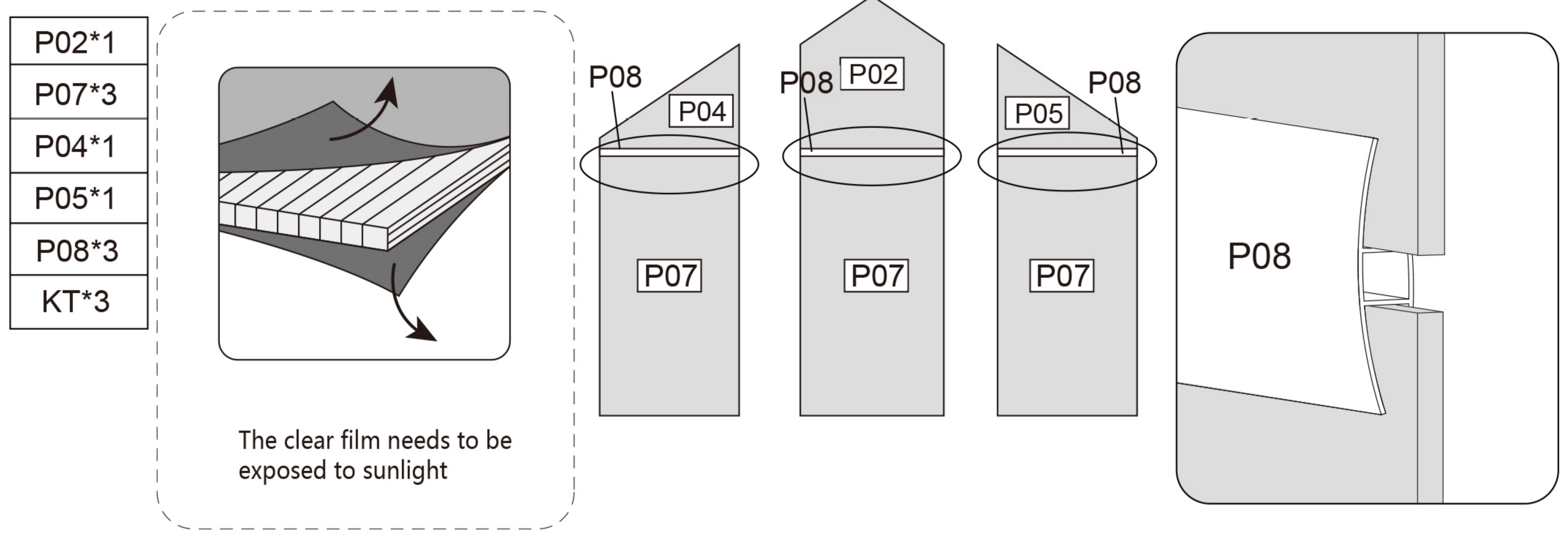

1. Connect panel P07 and panel P04 (P05) with P08
2. Connect panel P02 and panel P07 with P08

Note: Need leave a little distance when connected panel

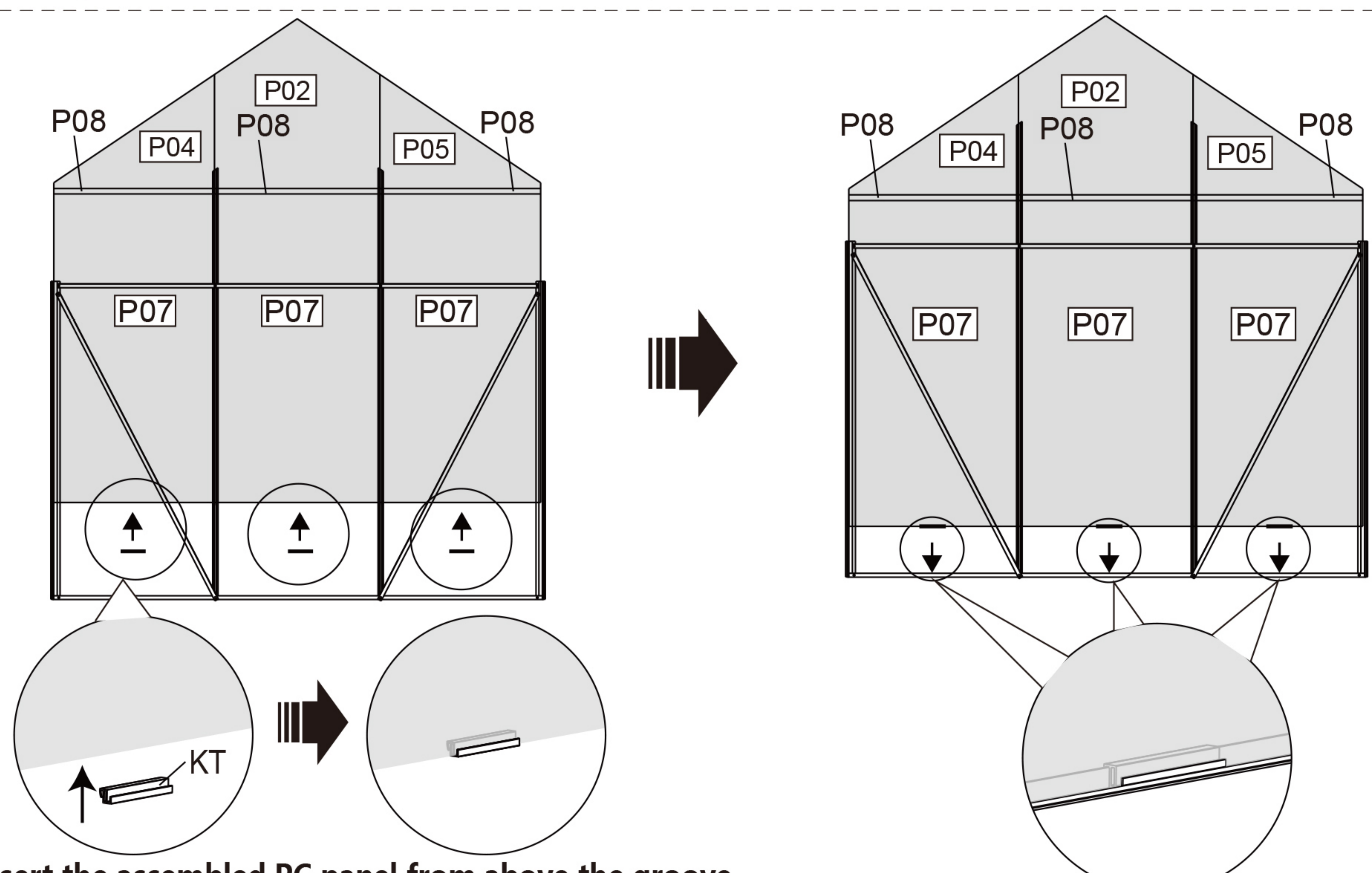

3. Insert the assembled PC panel from above the groove.

Note: In the process of inserting the PC Panel, if it is too loose or too tight, you can loosen the nut at the relevant position to properly adjust the position and spacing of the PC Panel, so that the PC panel can be inserted and installed smoothly.

STEP 5

RG04L*1
RG04R*1
LD02*8
LM01*8

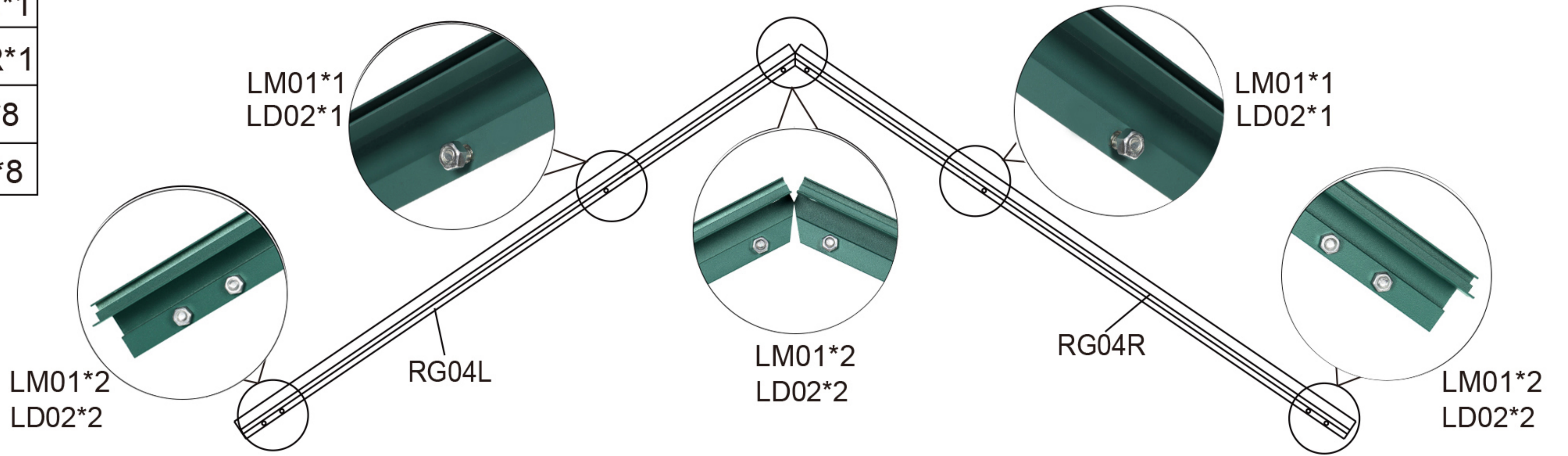

Do not tighten the nut . Only loosely screw it onto the thread .

STEP 6

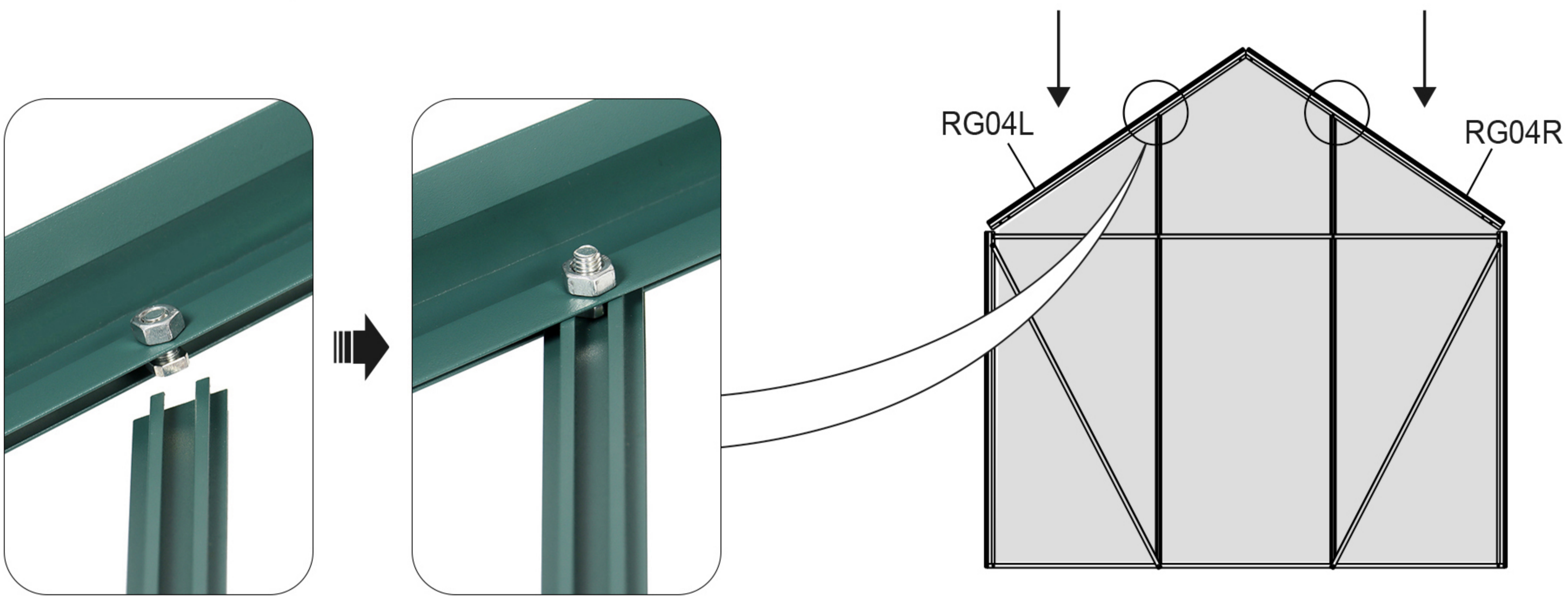

Insert the PC panel into the reserved groove of RG04R and RG04L.
Then Press it down into place.
The bolt LD02 need to insert into the grooves and fasten the nuts.

STEP 7

BJ04*1
BJ05*2

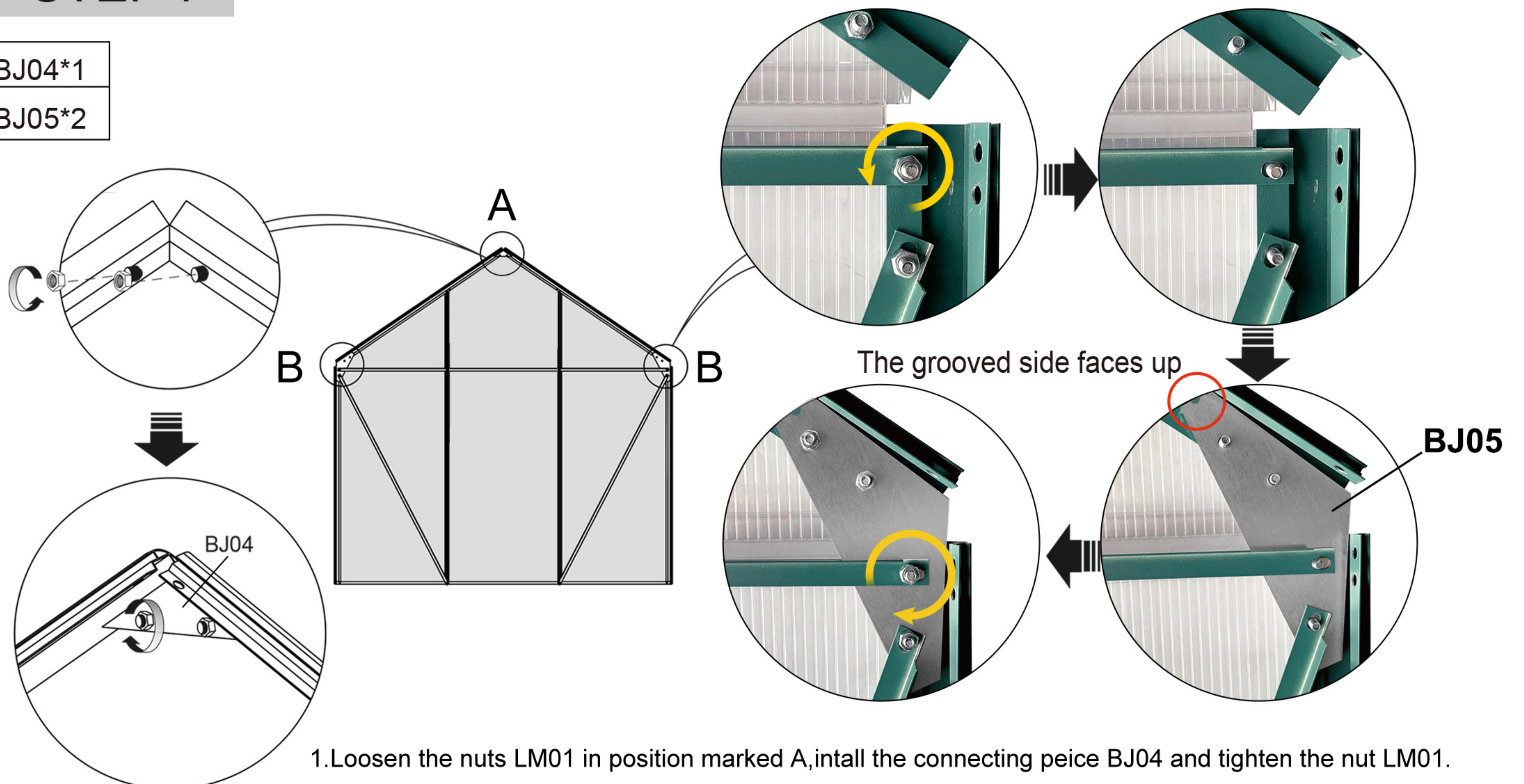

1. Loosen the nuts LM01 in position marked A, install the connecting piece BJ04 and tighten the nut LM01.
2. Loosen the nuts LM01 in position marked B, install the connecting piece BJ05 and tighten the nut LM01.

Side Wall Assembly

SG02 8PCS	SG04 8PCS	SG0383 2PCS	SG0384 2PCS	SG019L 2PCS	SG019R 2PCS	KT 10PCS
BJ06 2PCS	BJ07 2PCS	P07 10PCS	LD02 76PCS	LM01 76PCS		
		47"x24"x0.16"	M6x12	M6		

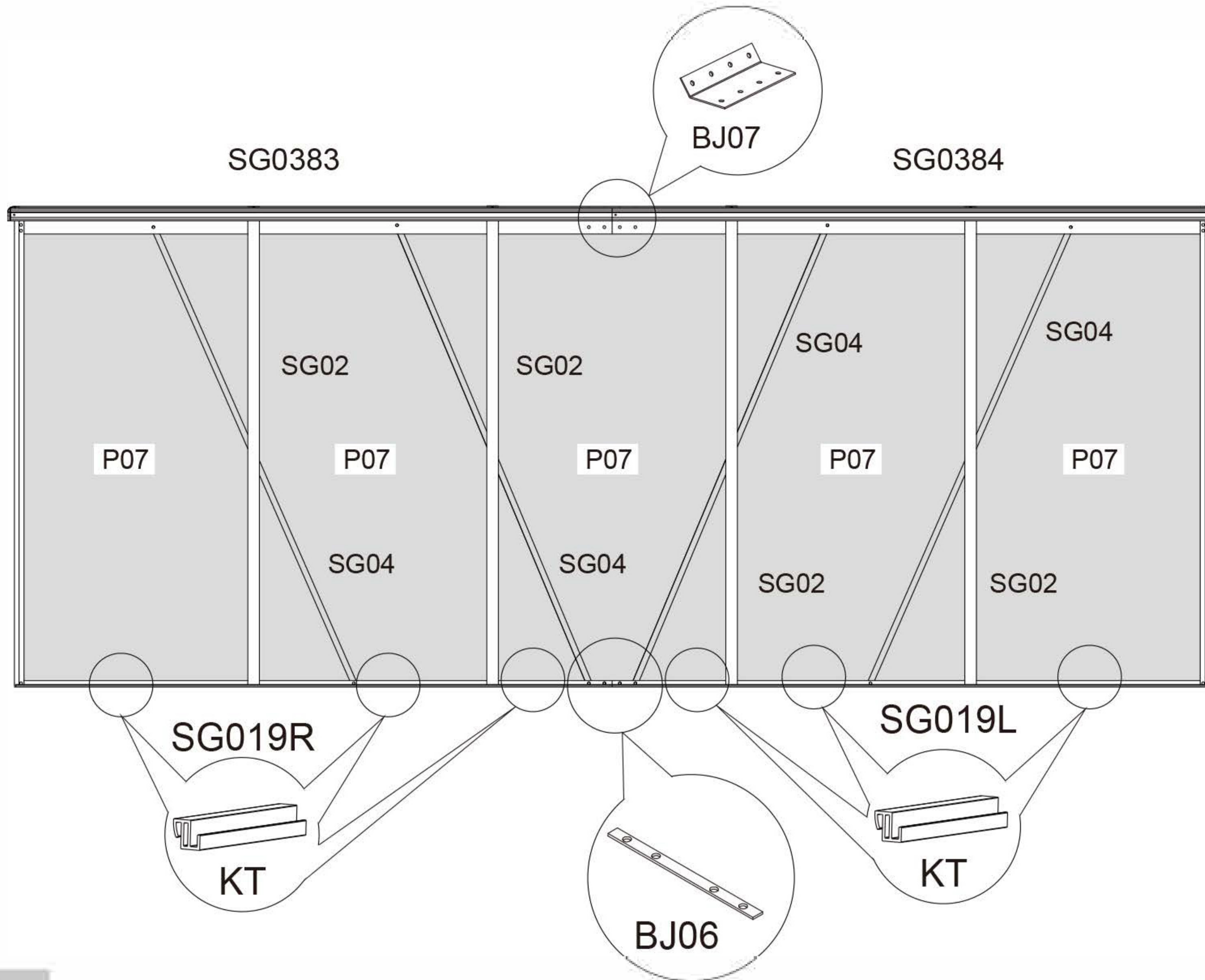

STEP 1

SG0383*2
SG0384*2
BJ07*2
LD02*28
LM01*28

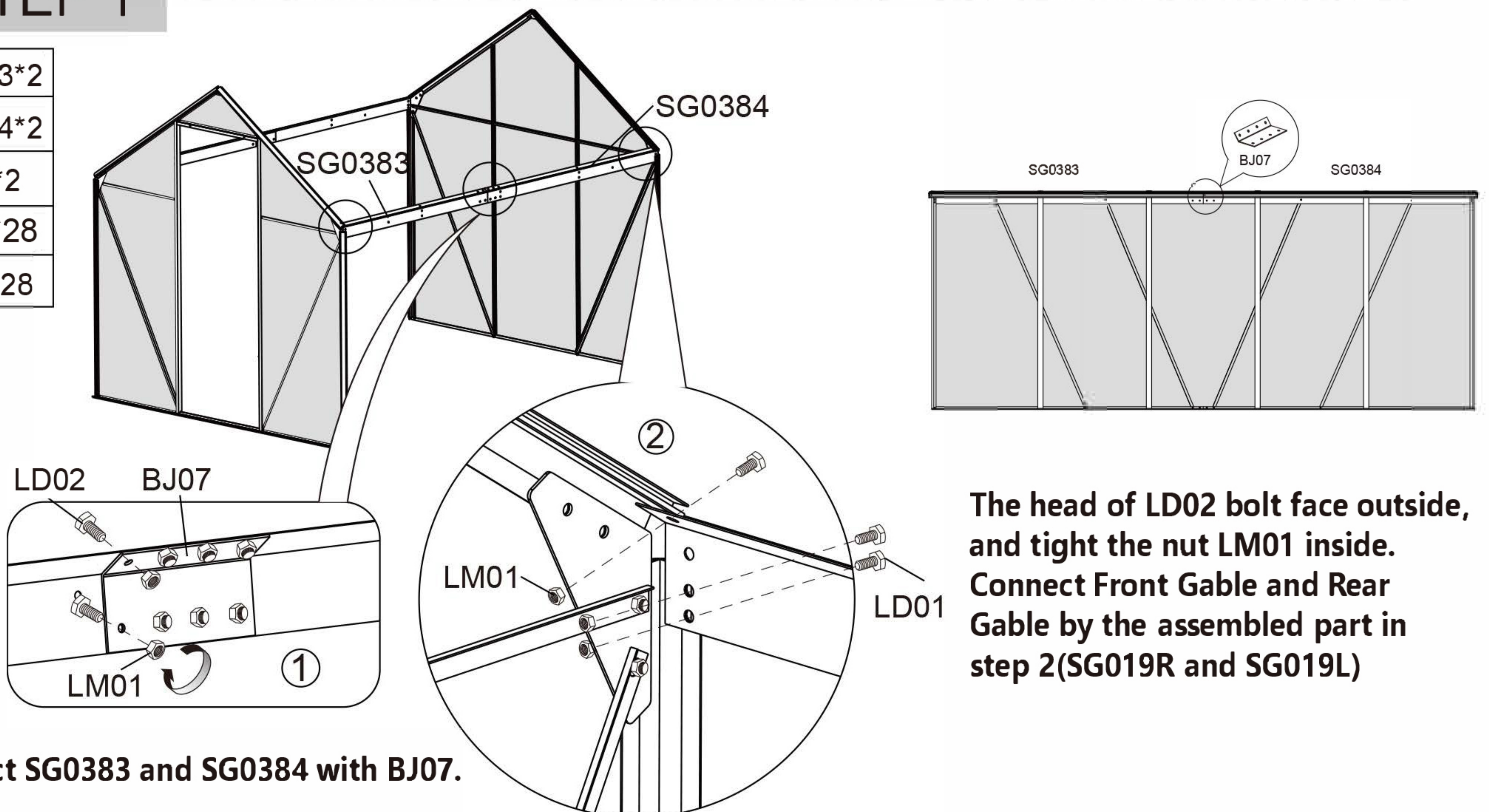

Connect SG0383 and SG0384 with BJ07.

STEP 2

SG019R*2
SG019L*2
BJ06*2
LD02*12
LM01*12

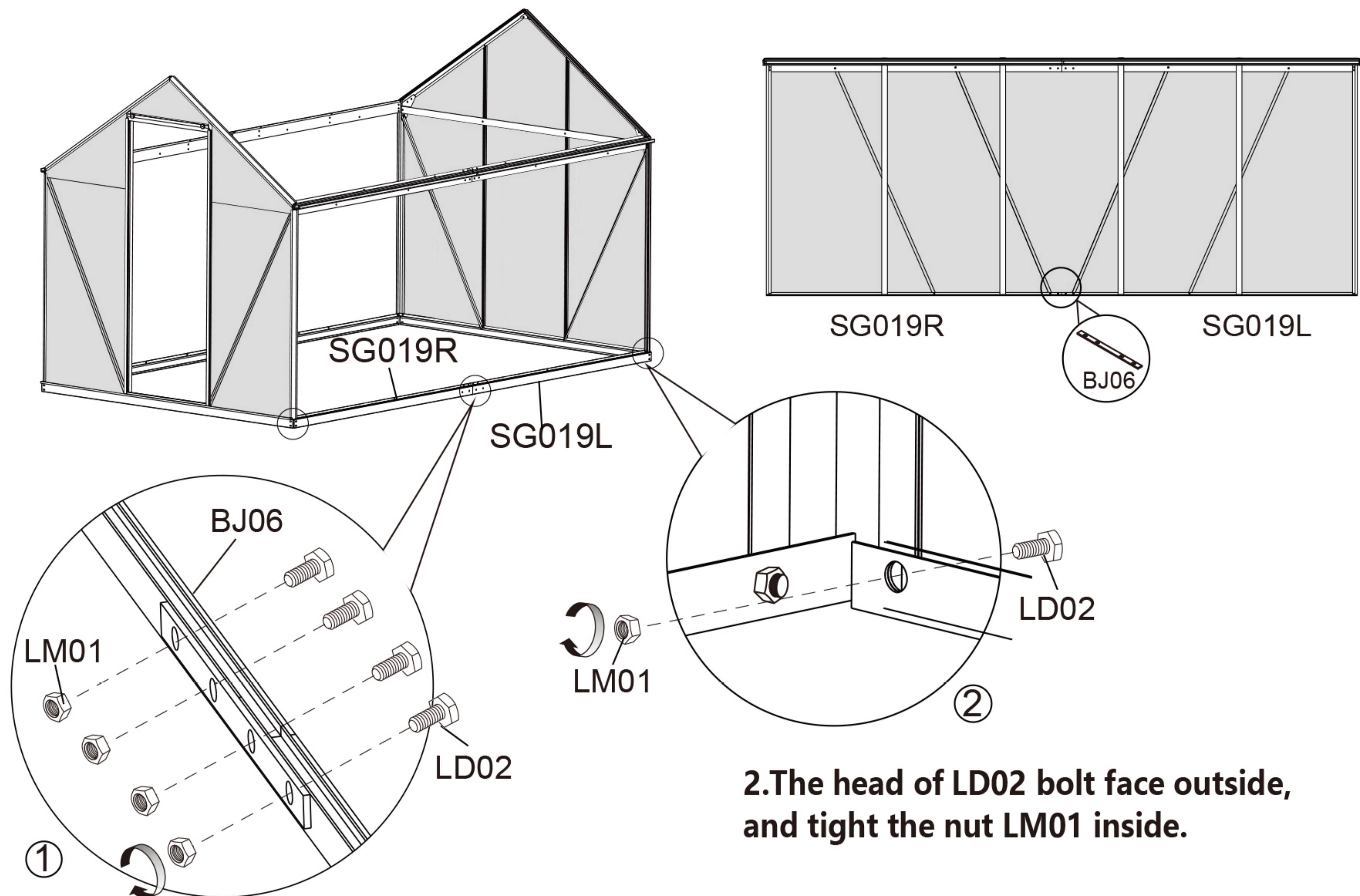

1.Connect SG019R and SG019L with BJ06.

STEP 3

The following shows only one side wall installation, the other wall side should install in the same method.

SG02*8
LD02*24
LM01*24
SG04*8

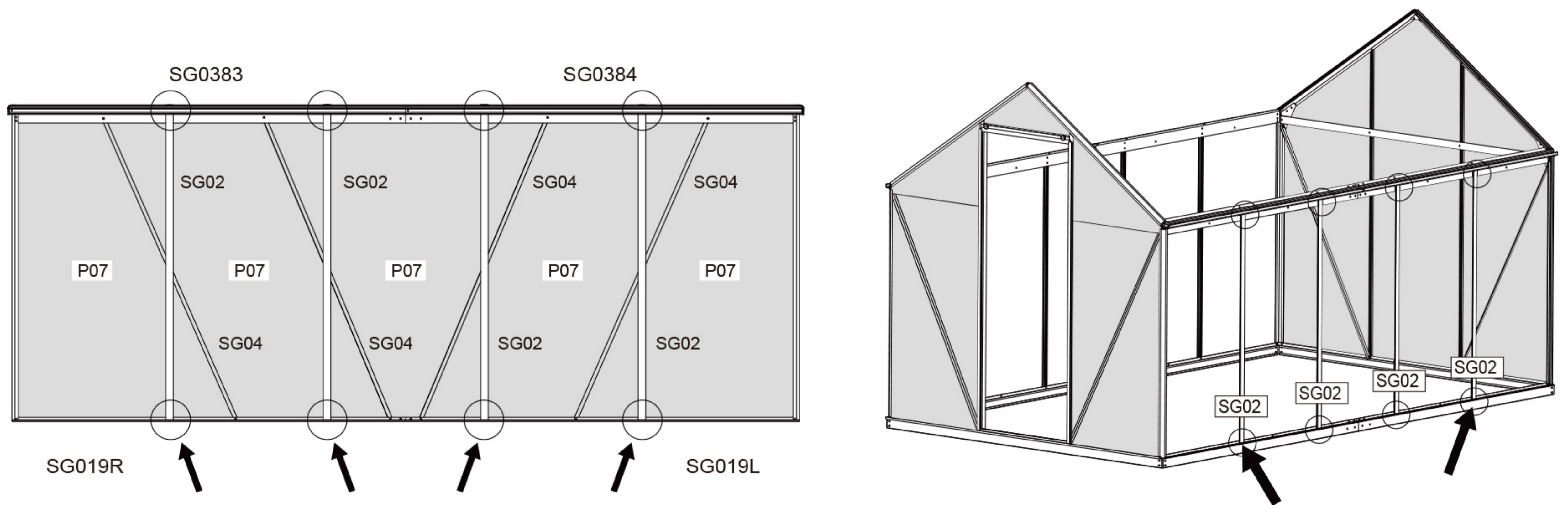

Each SG02 need to be pre-installed with 3 bolt LD02. The bolt in the middle is prepared for the next step and don't screw the nut.

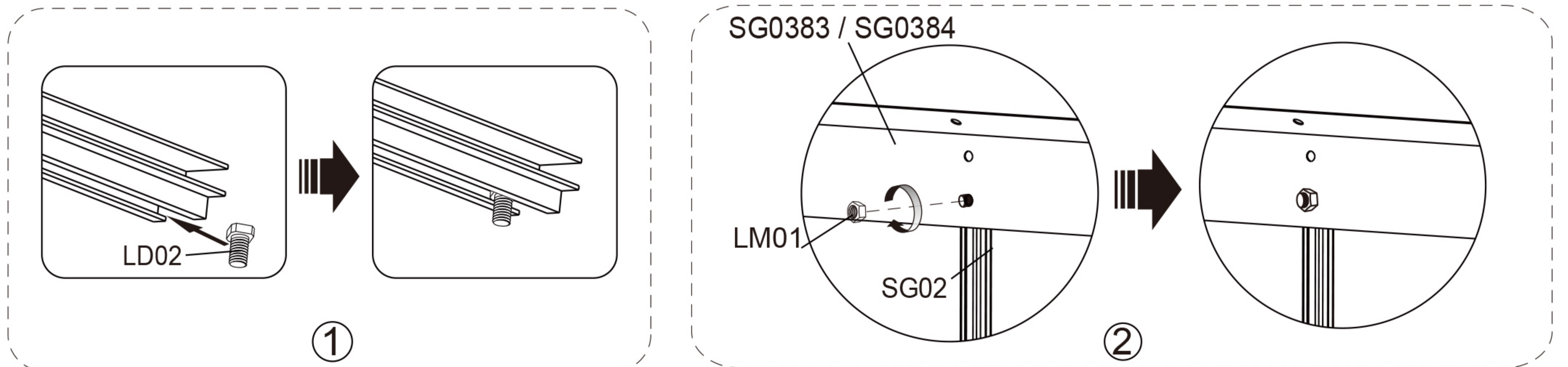

STEP 4

The following shows only one side wall installation, the other wall side should install in the same method. Connect SG02 and SG04 with one of the Pre-inserted bolt LD02 in SG02, and tighten with a nut.

- LD02*12
- LM01*12

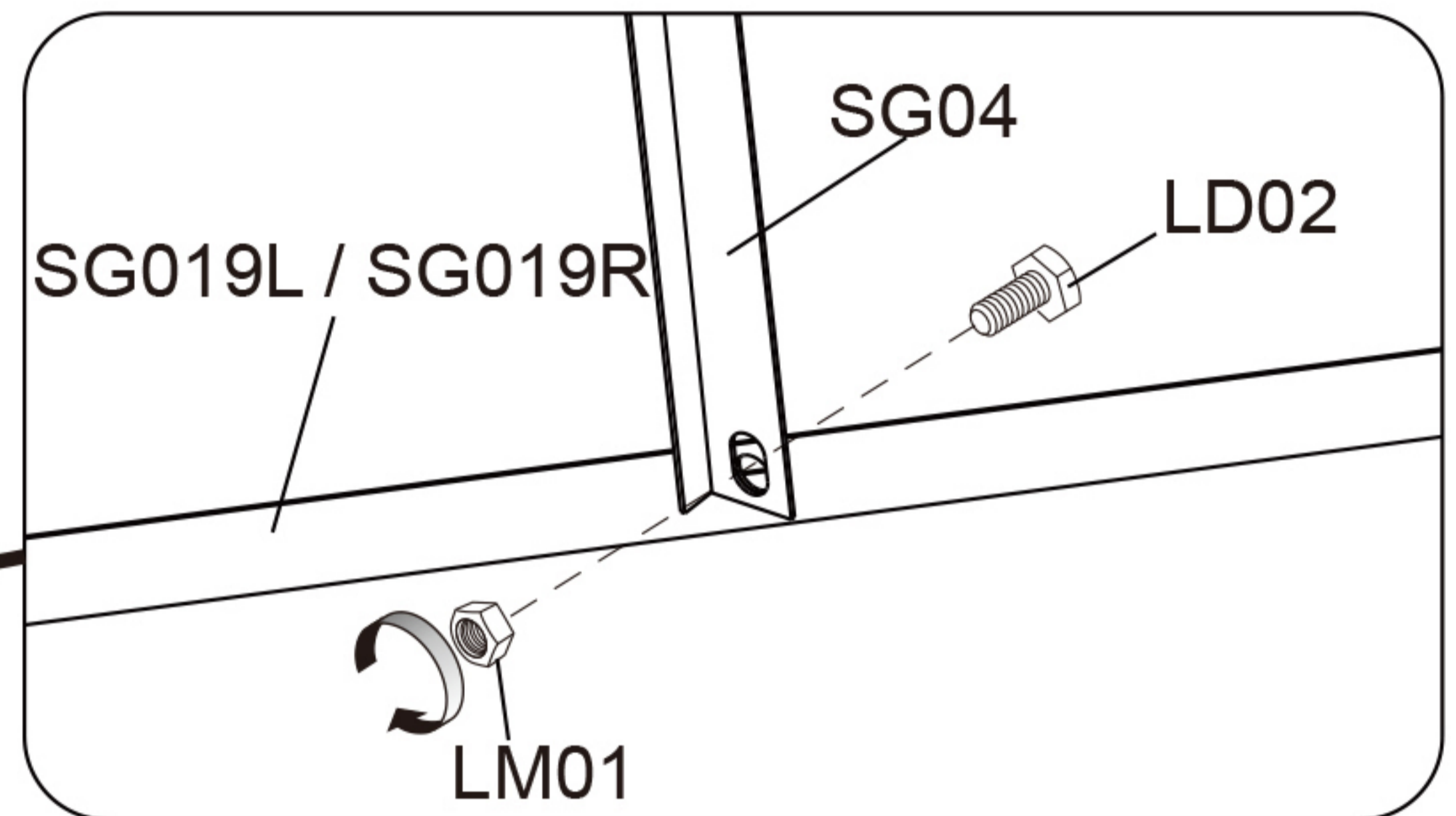
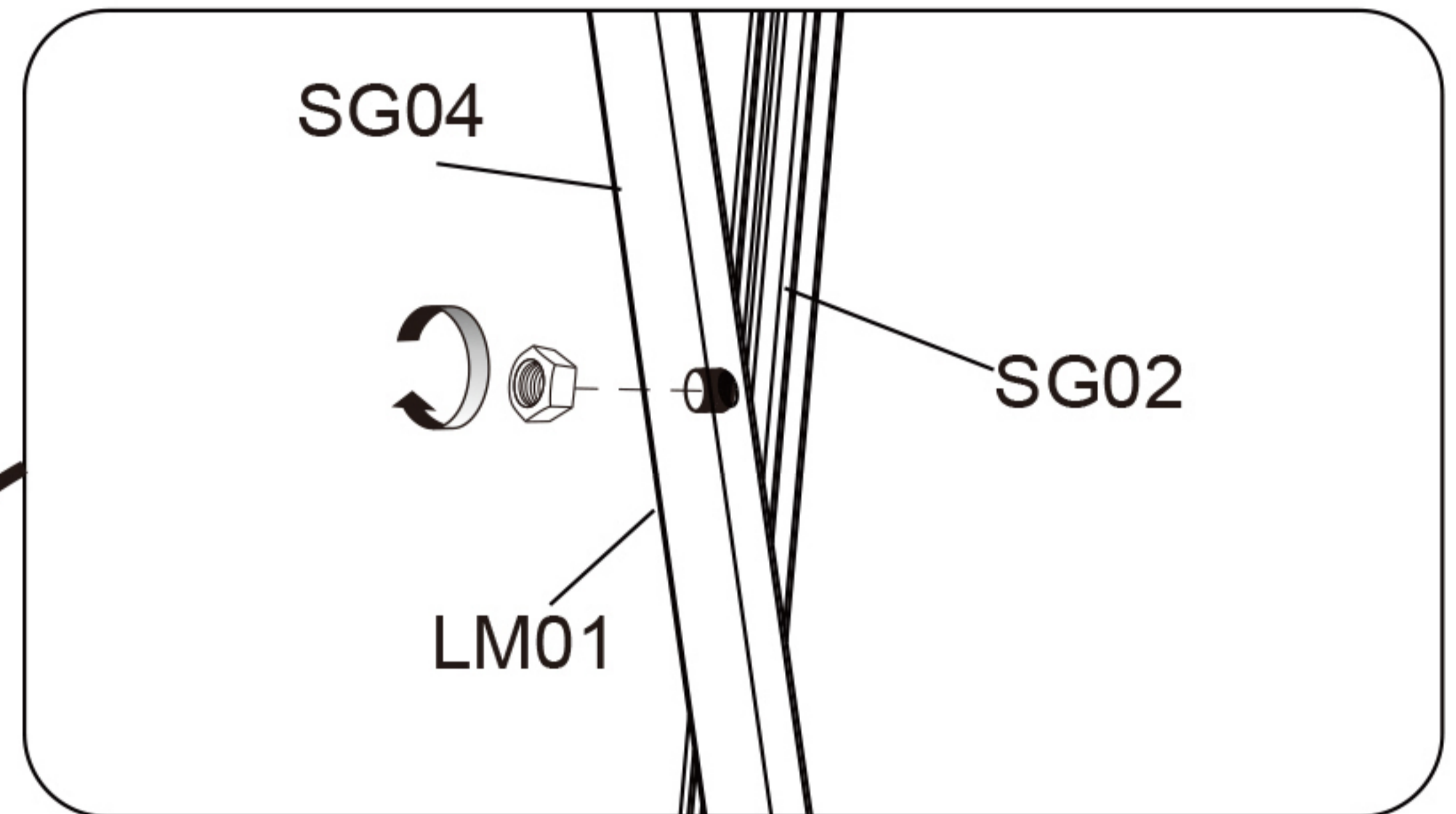
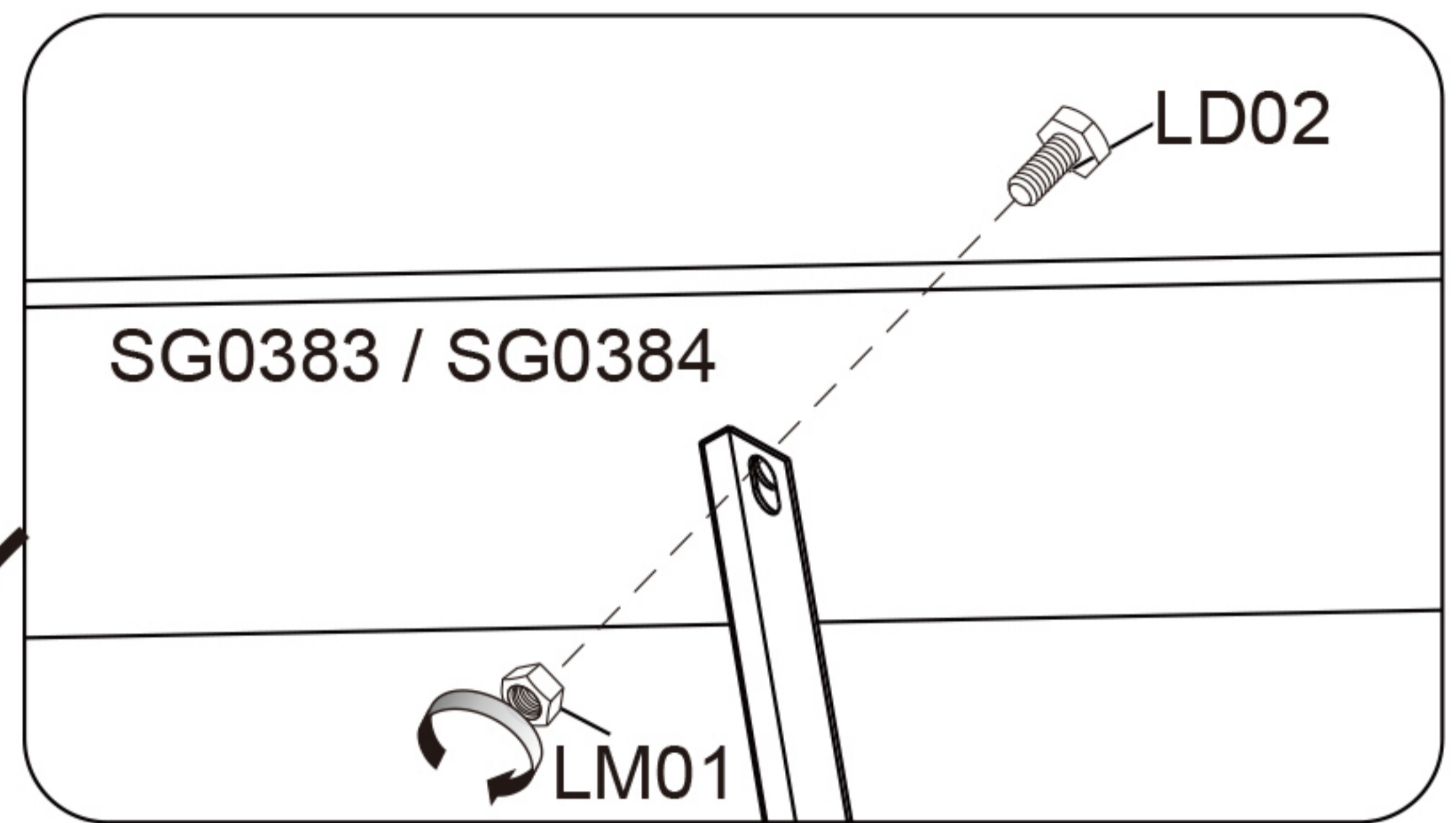
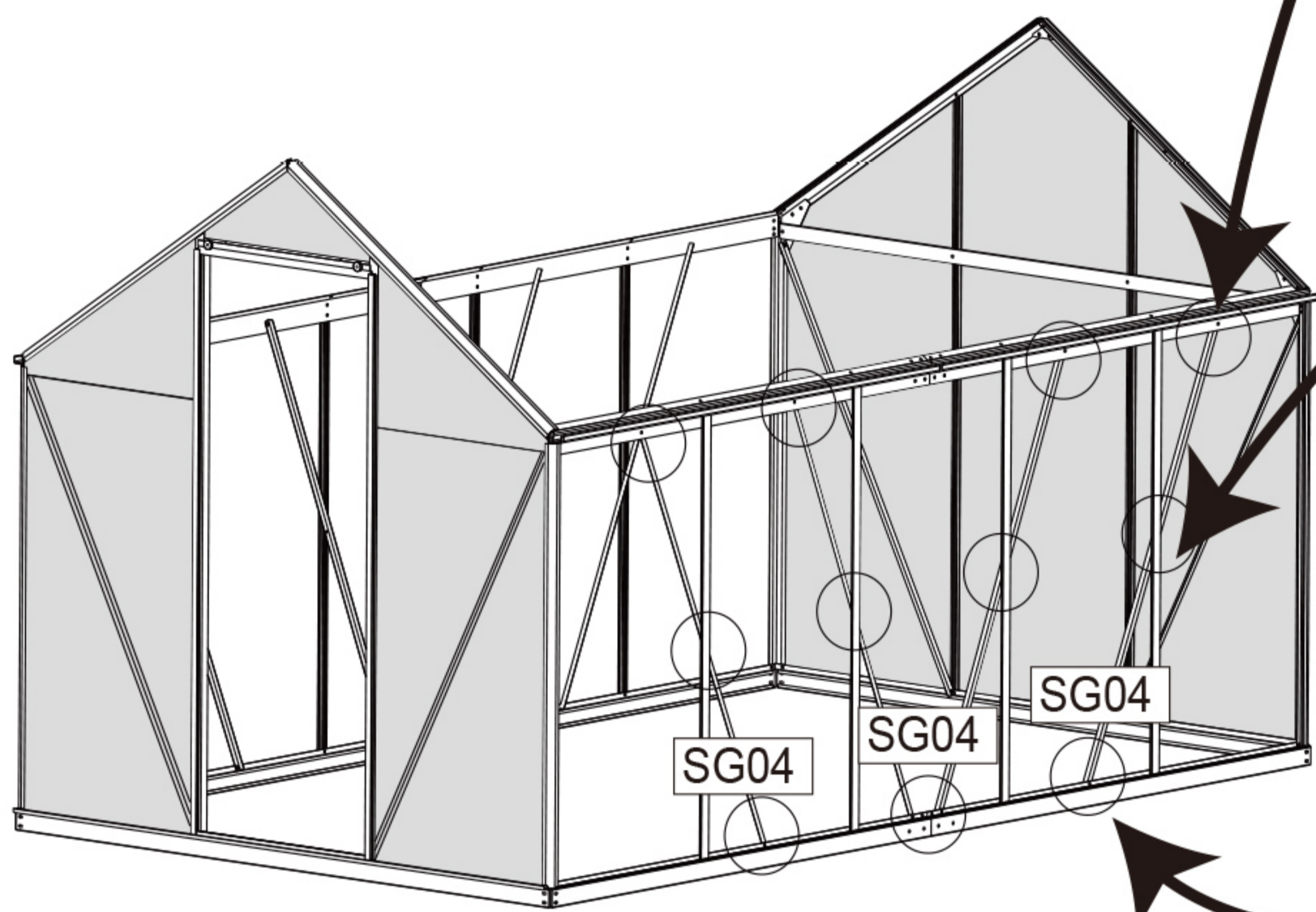
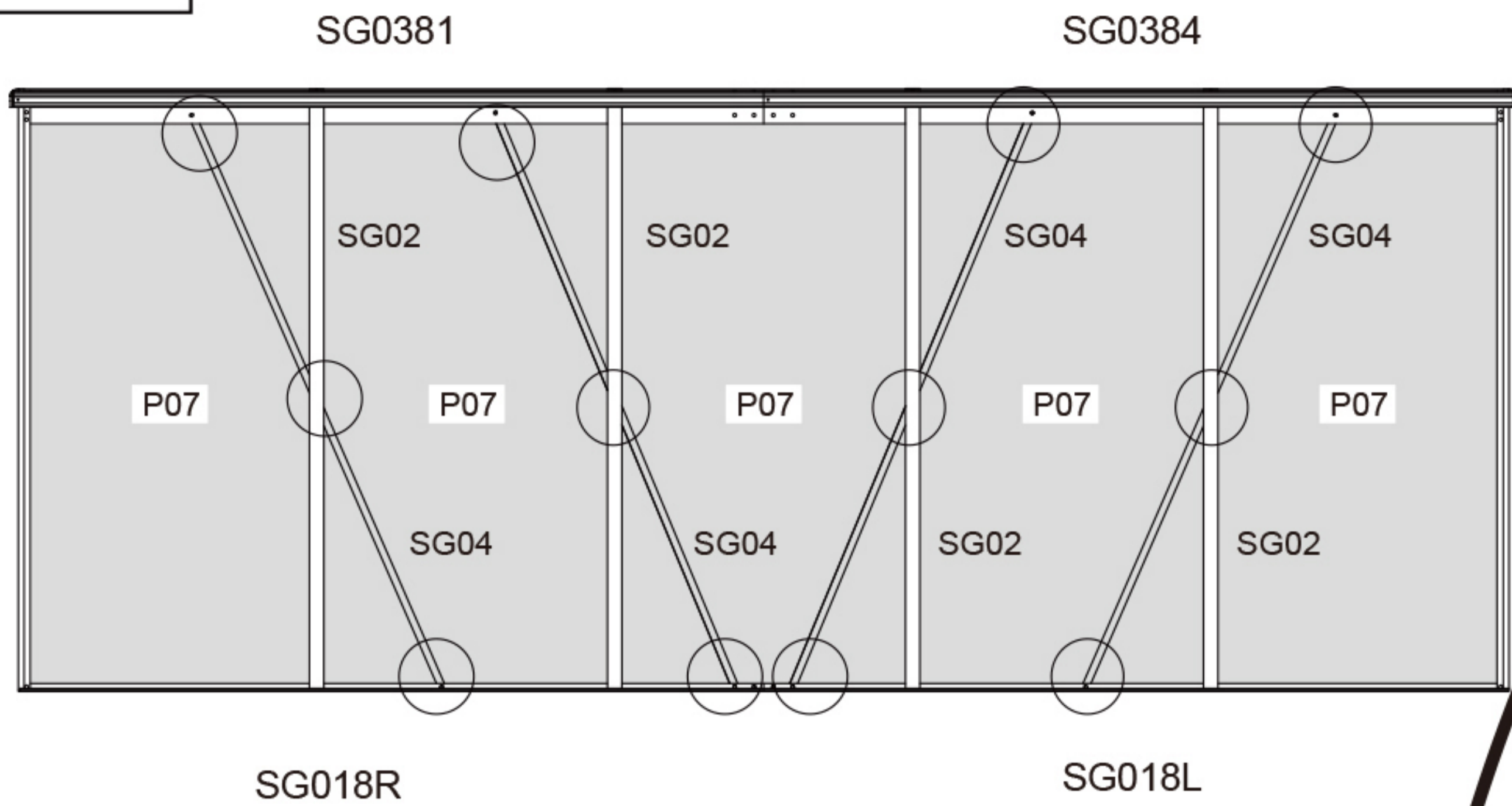

STEP 5

- P07*10
- KT*10

Insert the assembled PC panel P07 from above the groove.

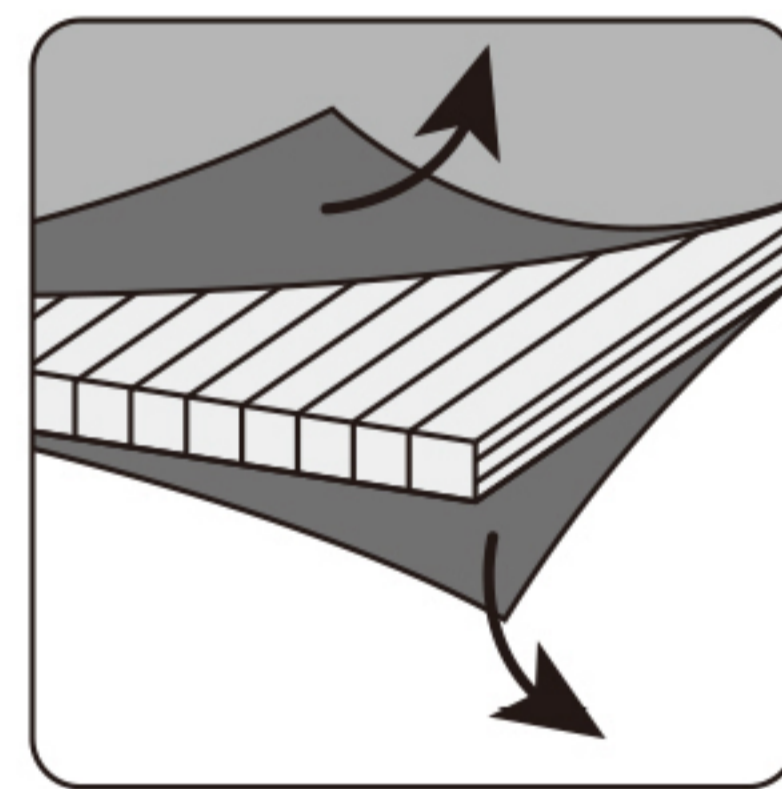
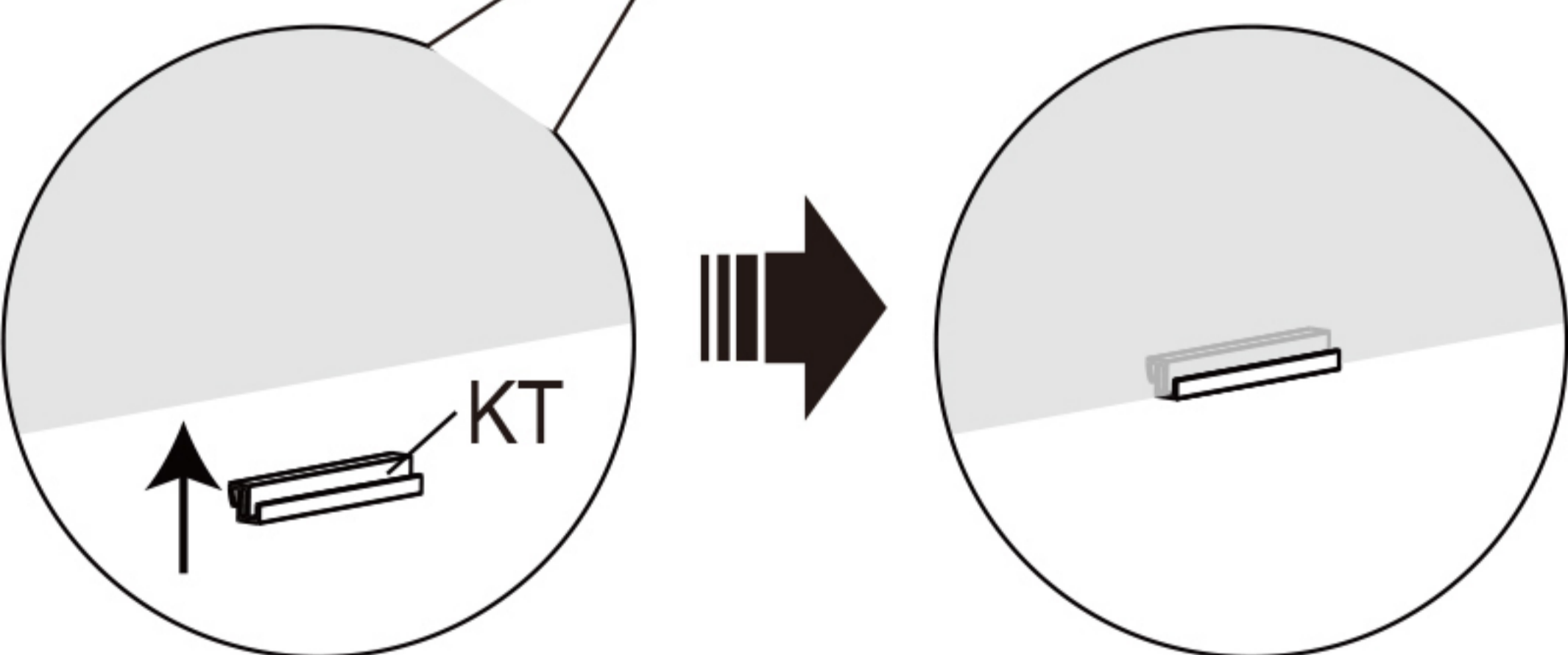
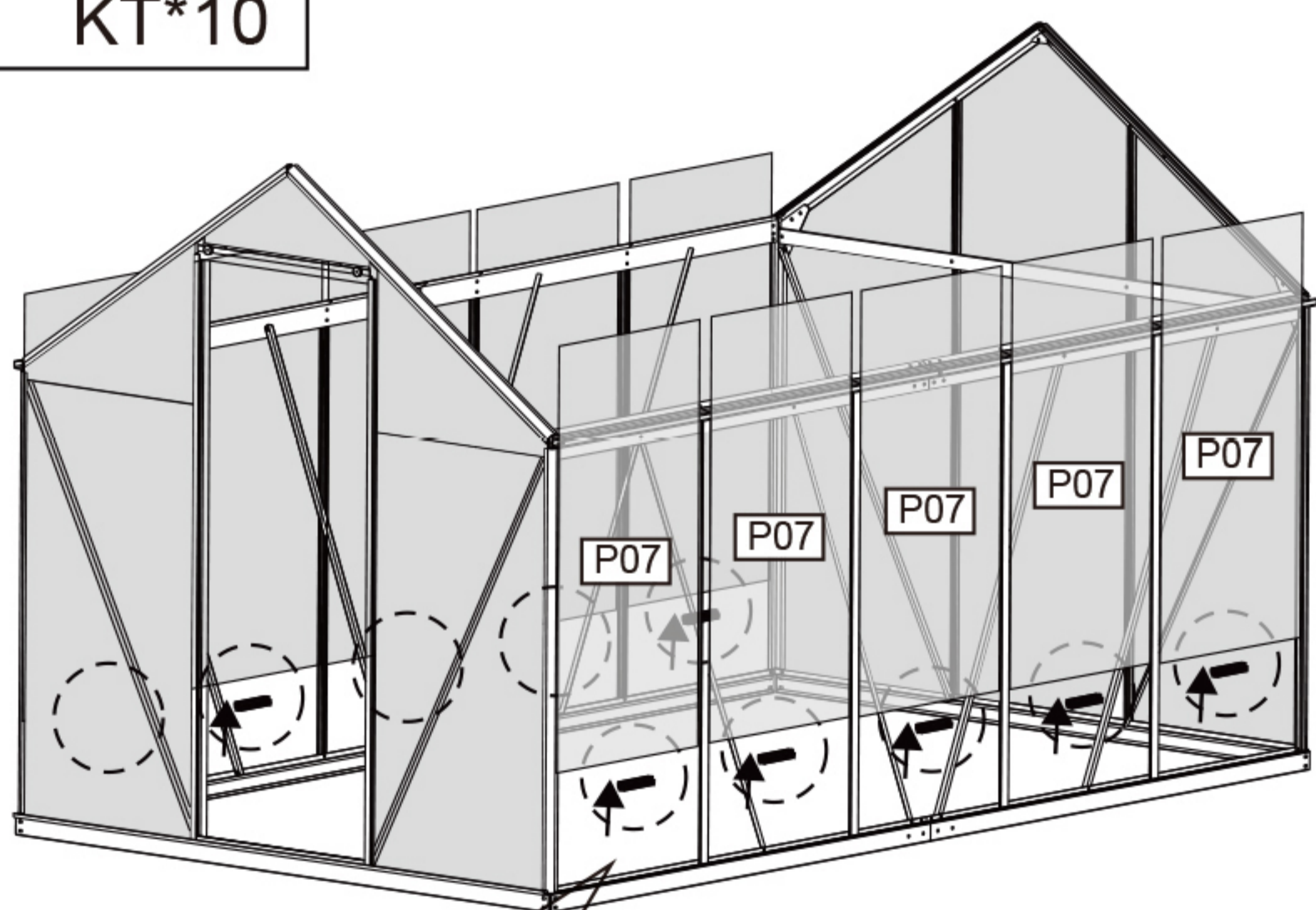



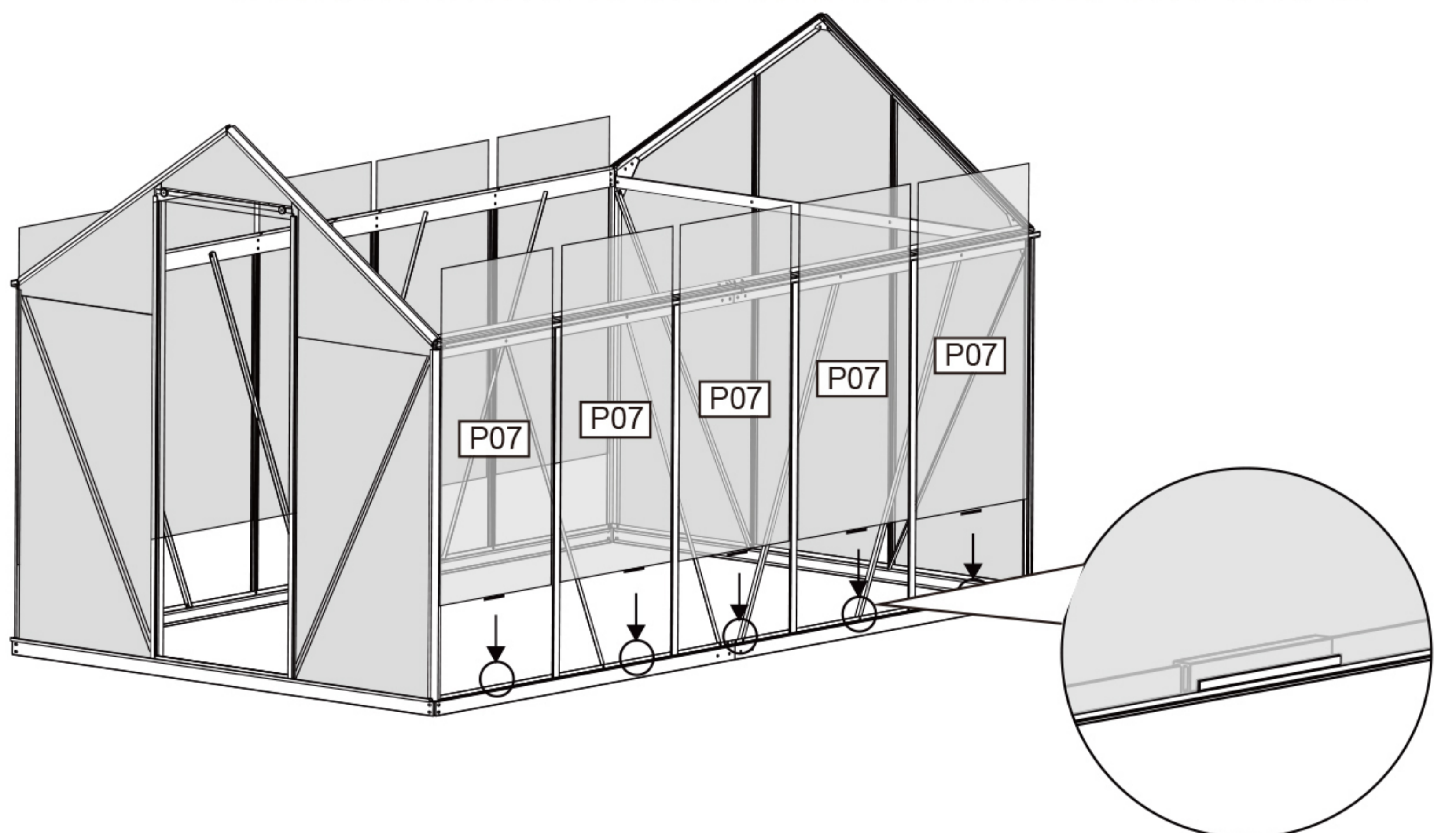



The clear film needs to be exposed to sunlight

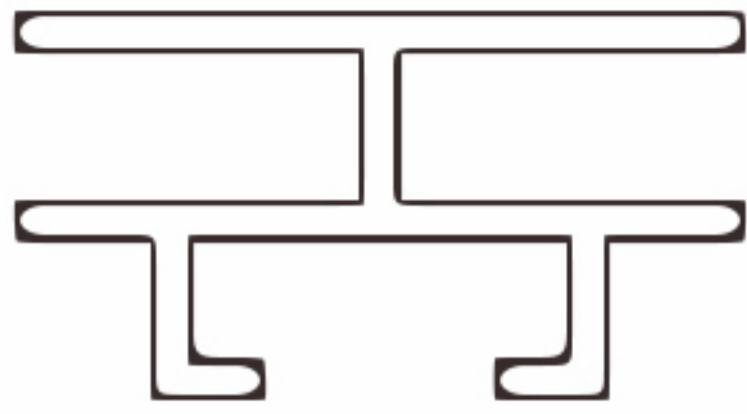
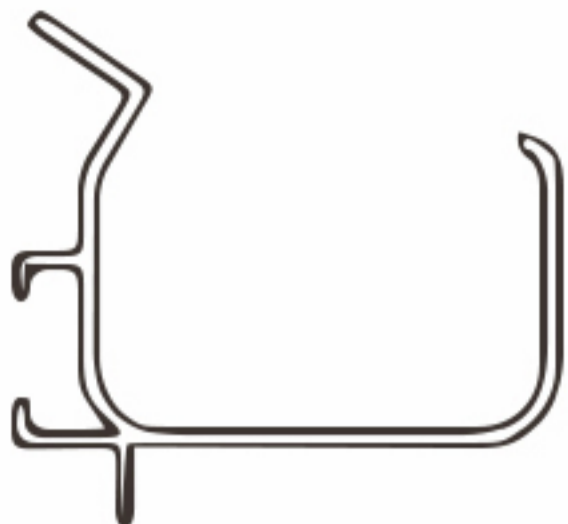
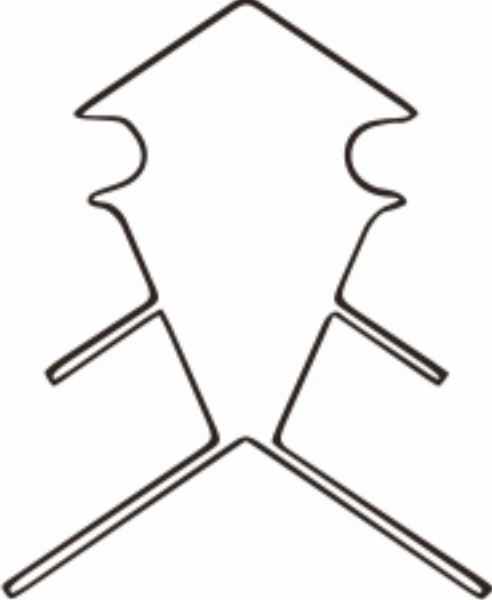
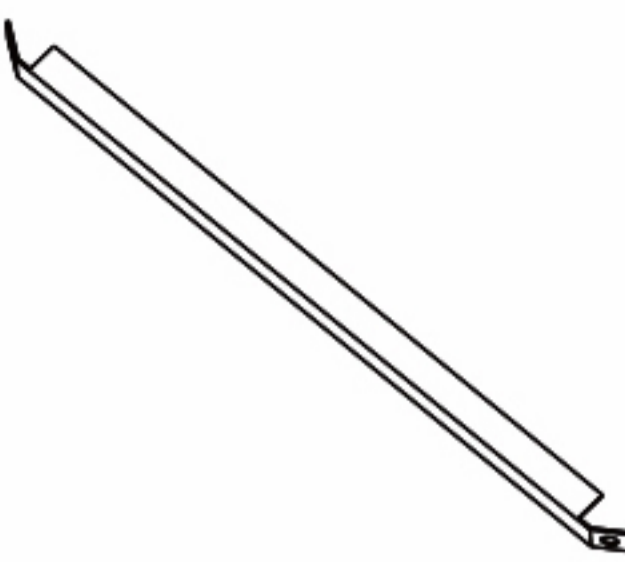
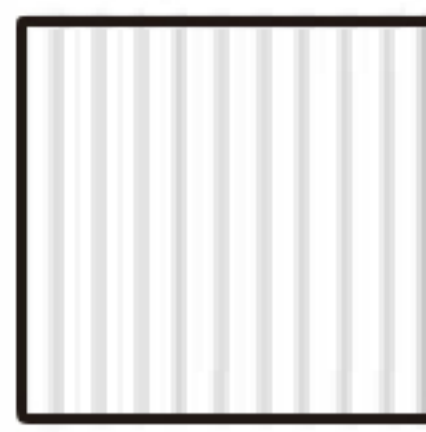

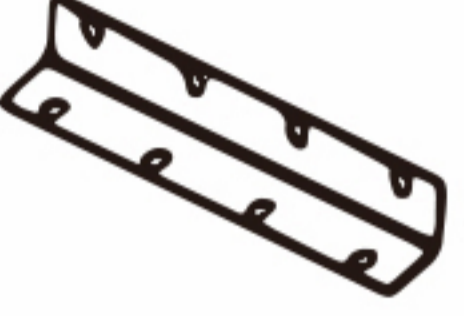
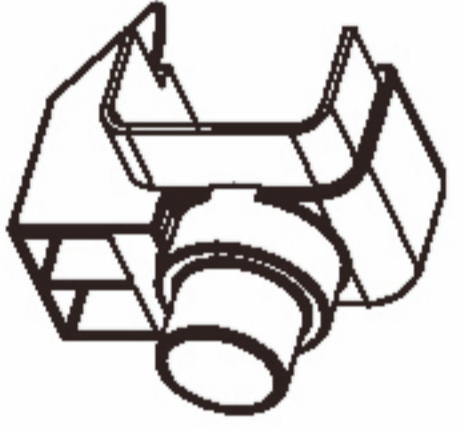
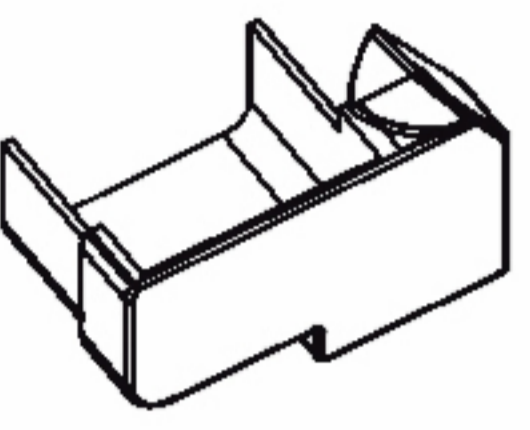
Note: In the process of inserting the PC Panel, if it is too loose or too tight, you can loosen the nut at the relevant position to properly adjust the position and spacing of the PC Panel, so that the PC panel can be inserted and installed smoothly.

Roof Assembly

SG02 8PCS 	R029 4PCS 	R0183 2PCS 	SR06 4PCS 	P03 2PC  23"x24"x0.16"		
P07 8PCS  43.5"x24"x0.16"	BJ08 1PC 	SL04 2PCS 	SL05 2PCS 	LD02 40PCS  M6x12	LD05 4PCS 	LM01 40PCS  M6

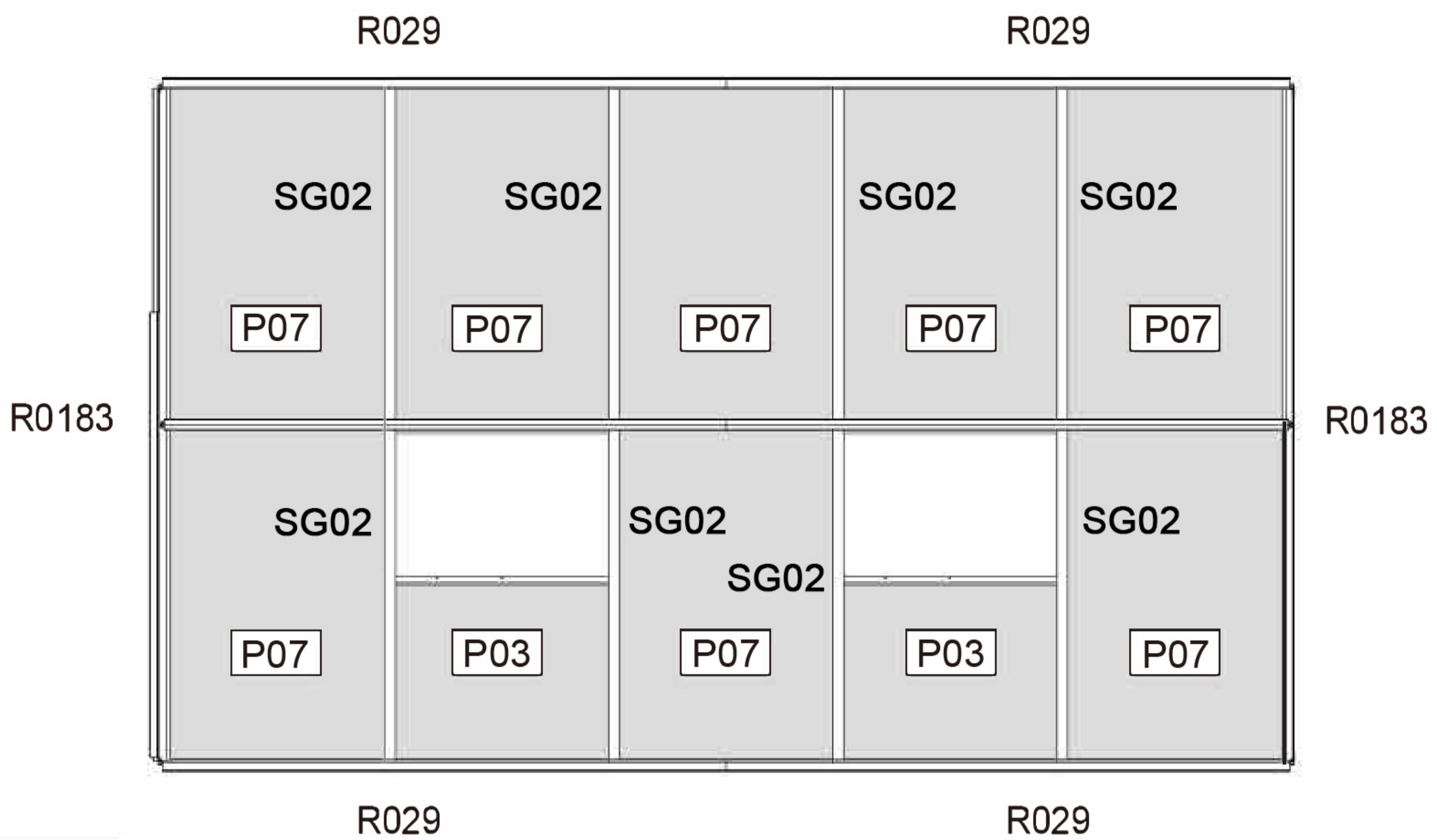

STEP 1

- R0183*2
- LD02*12
- LM01*12
- BJ08*1

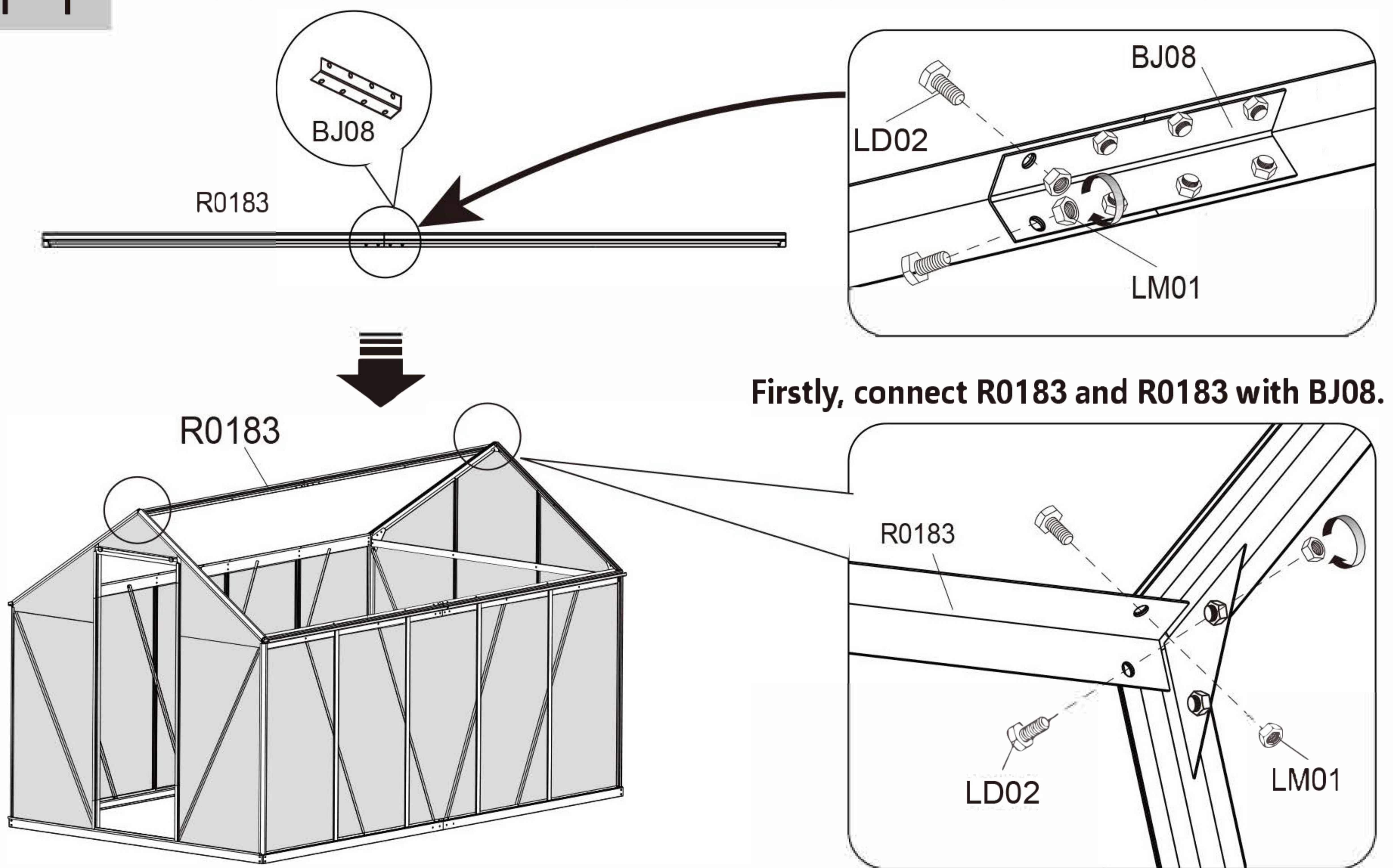

Connect Front Gable and Rear Gable by the assembled part in step 1 (R0183)

STEP 2

- SG02*8
- LD02*24
- LM01*20

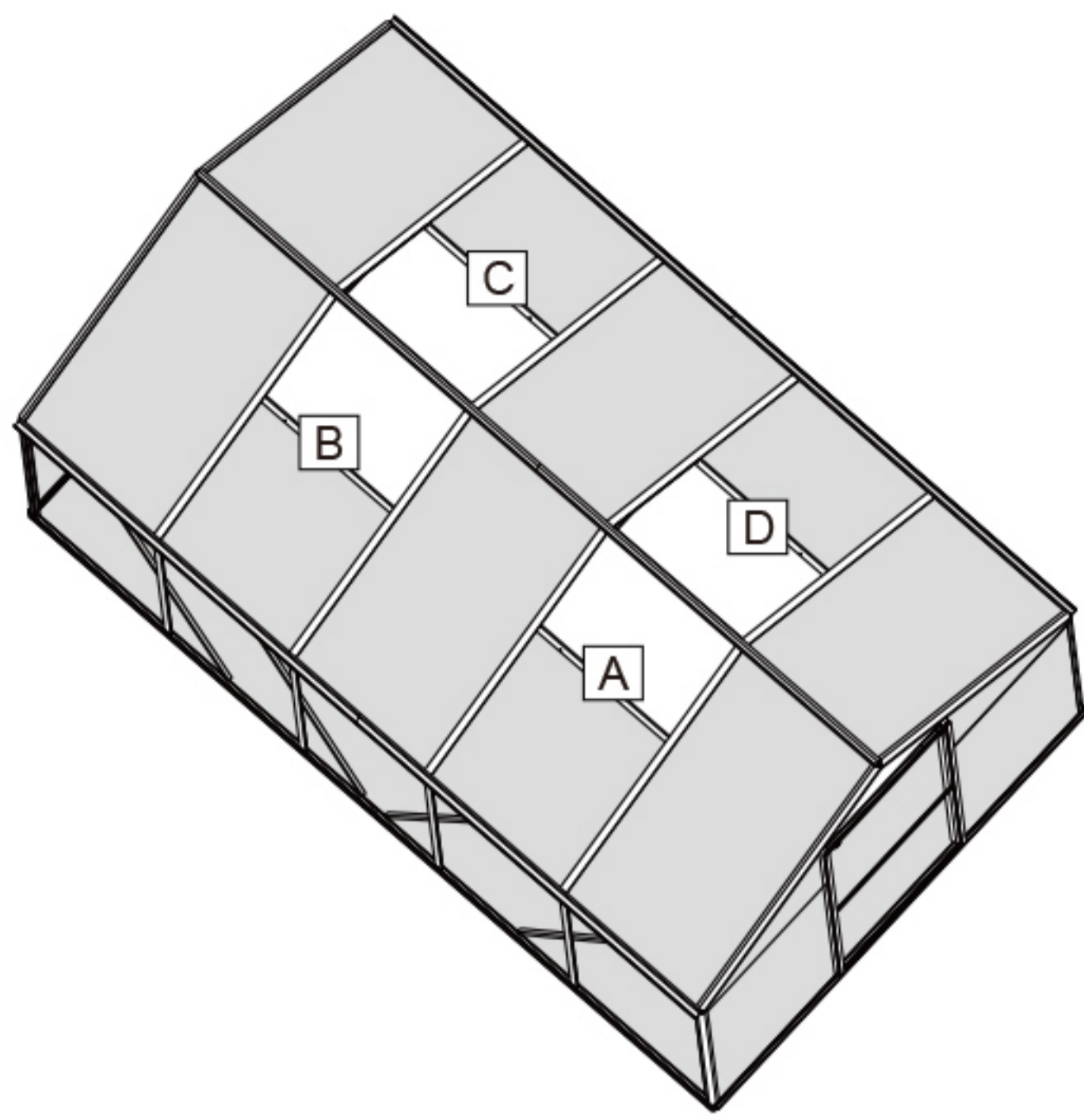

Vent can be installed in the 4 areas (A, B, C, D) shown in the figure. The following installation steps are based on installing vent in area A as an example. If you want to install vent in other areas (B,C,D), the pre-inserted screws position needs to be changed accordingly.

The 4 SG02 marked by Arrow below need to be put into 3 bolt LD02 each in advance. The bolt in the middle is prepared for the next step. Don't screw the nut.

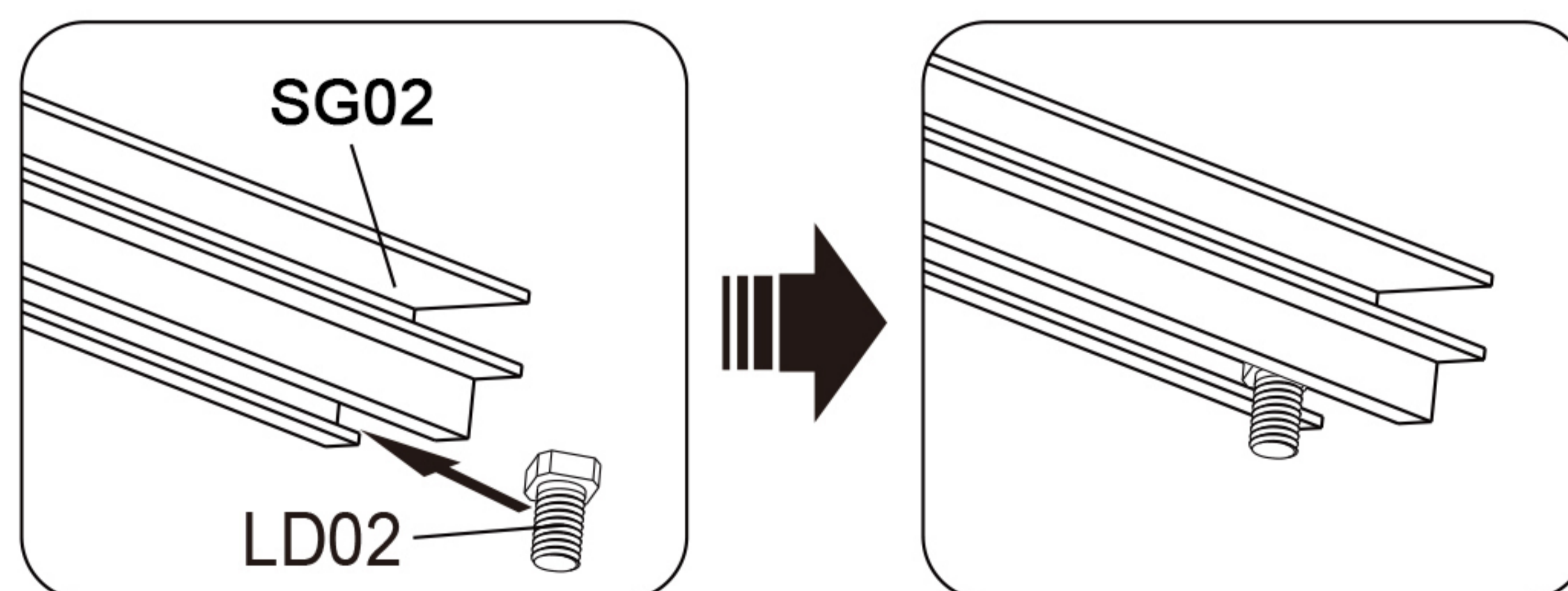
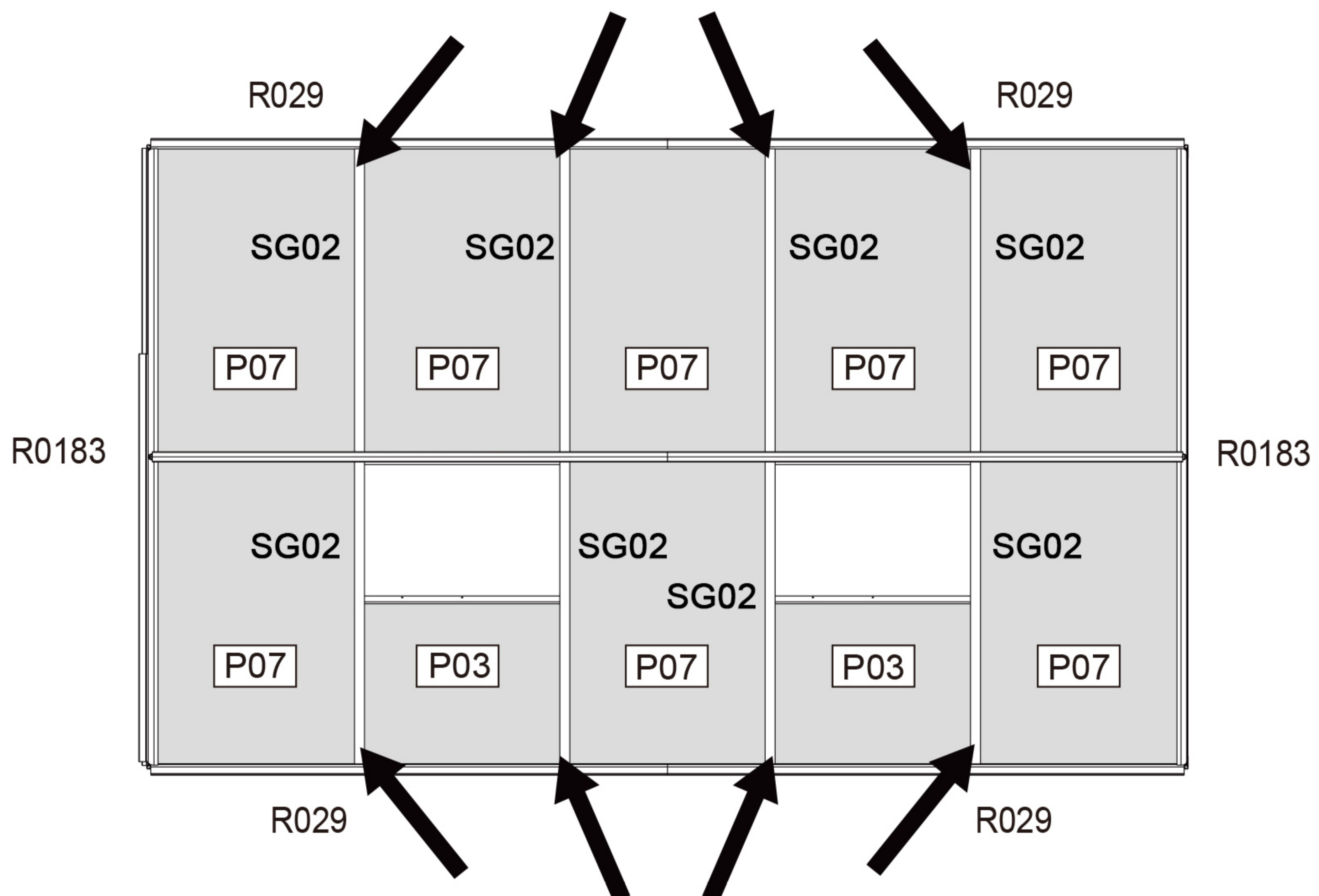

The 4 SG02 marked by Arrow above need to be put into 4 bolt LD02 each in advance. The 2 bolts in the middle is prepared for the next step. Don't screw the nuts.

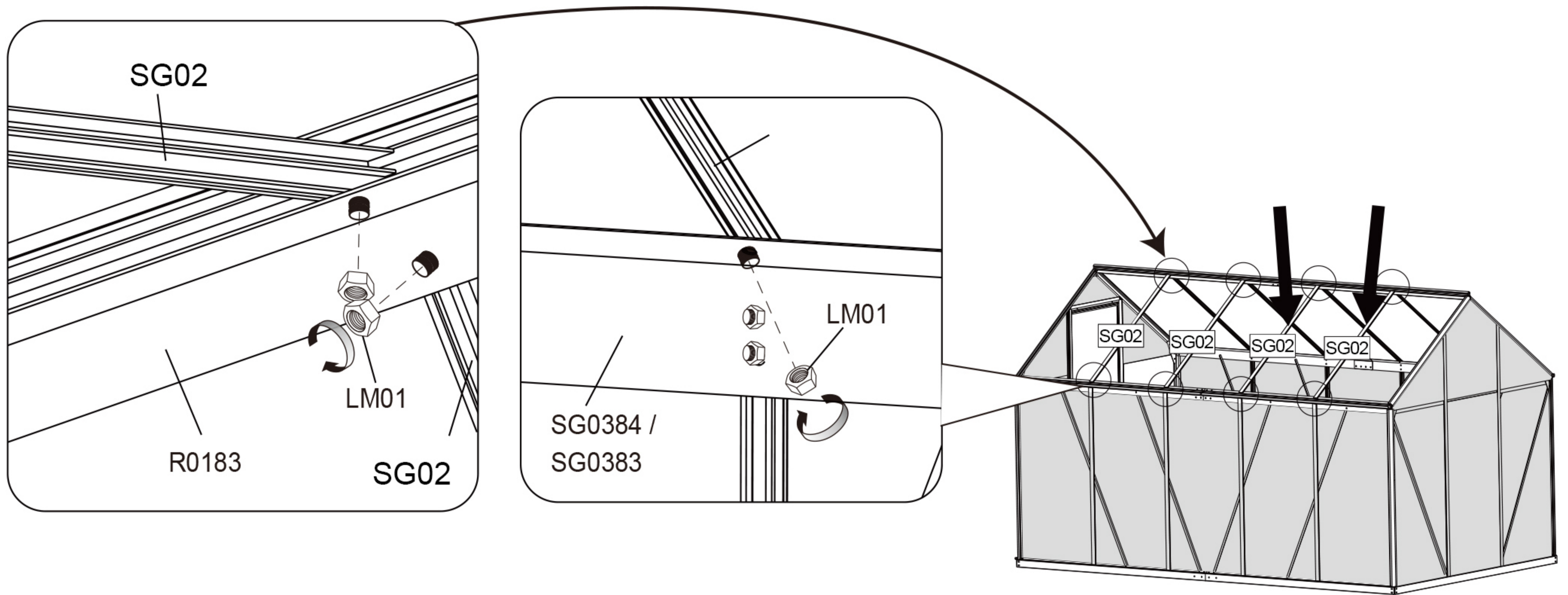

STEP 3

Connect SG02 and SR06 with the LD02 pre-installed in SG02 and fasten them with nuts.

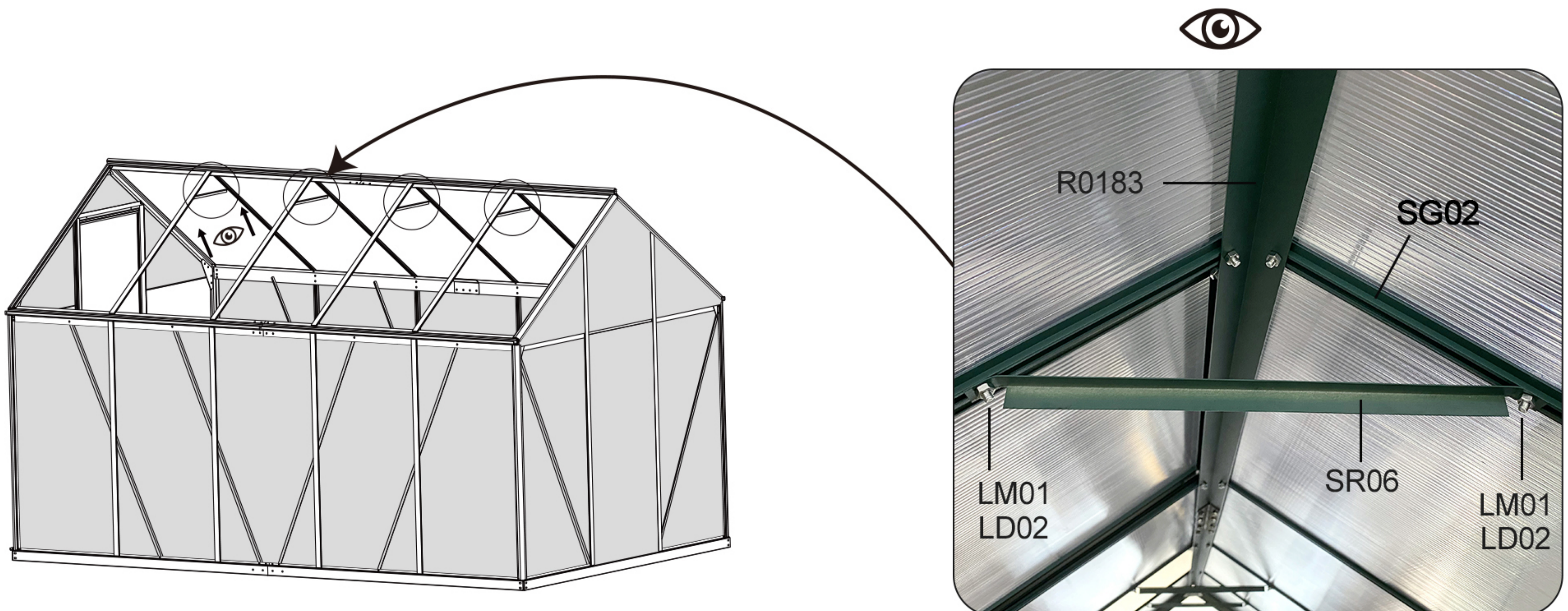

STEP 4

P07*8
P03*2

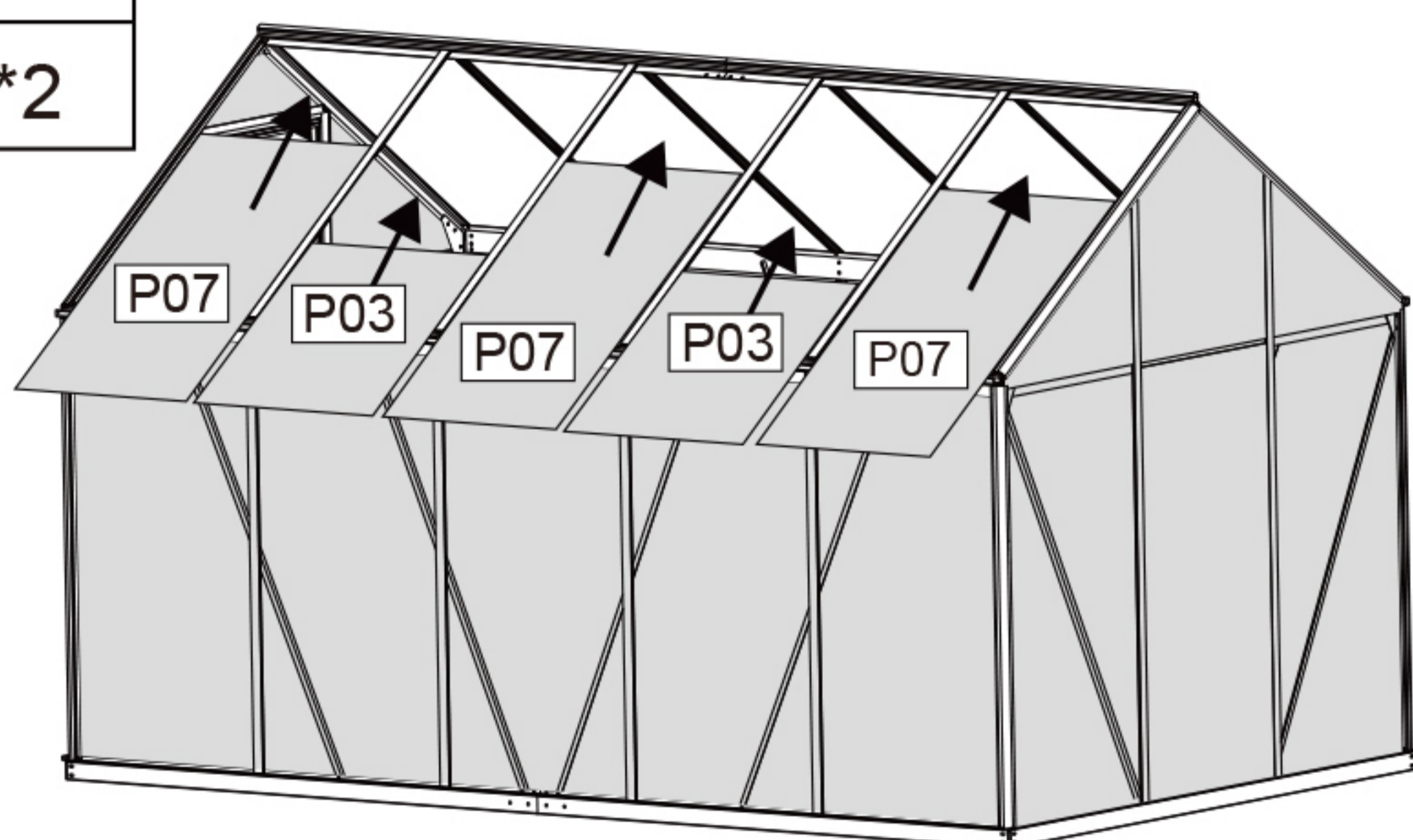

Insert the assembled PC panel P07 and P03 from groove.

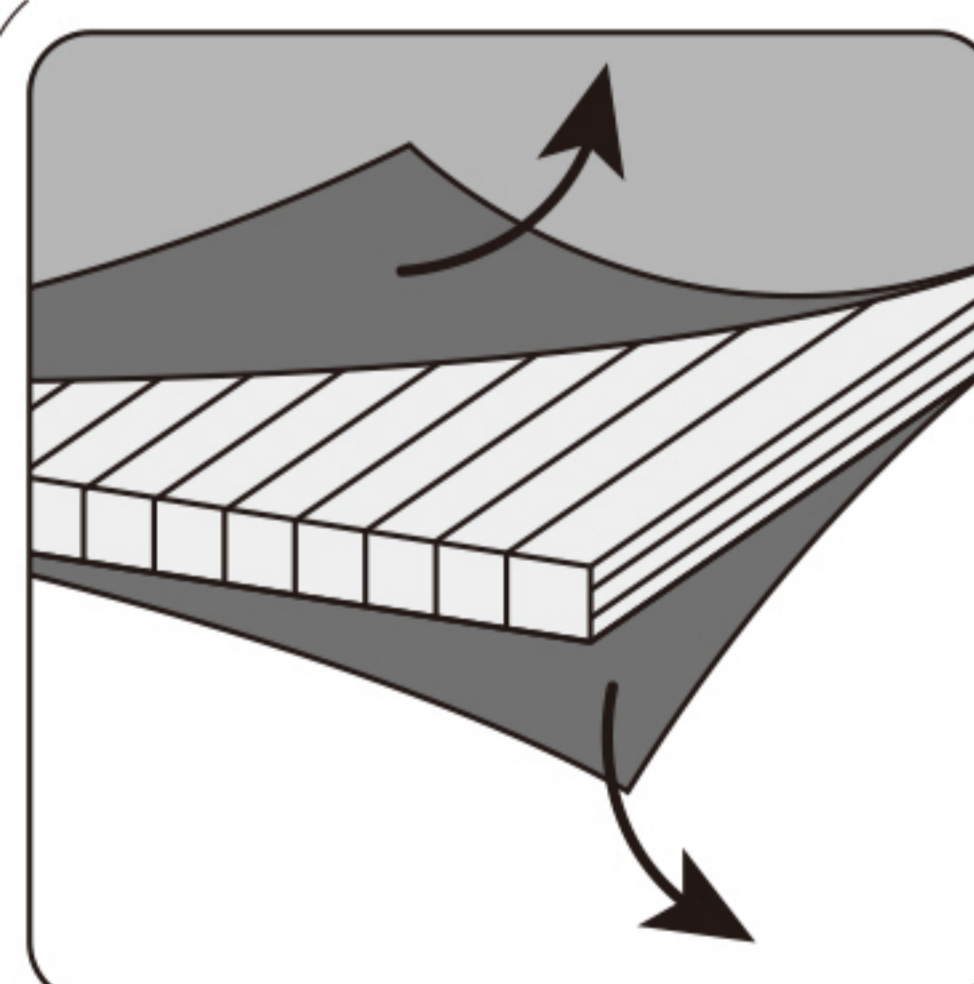

The clear film needs to be exposed to sunlight



Note: In the process of inserting the PC Panel, if it is too loose or too tight, you can loosen the nut at the relevant position to properly adjust the position and spacing of the PC Panel, so that the PC panel can be inserted and installed smoothly

STEP 5

R029*4

LD02*12

In this step, 4 pieces R029 will be used, and 2 pieces R029 are installed on same side. The following description is only for one side, and the other side should be installed in the same way. Each R029 need to be slid into 3 bolt LD02 in advance. Don't screw the nuts.

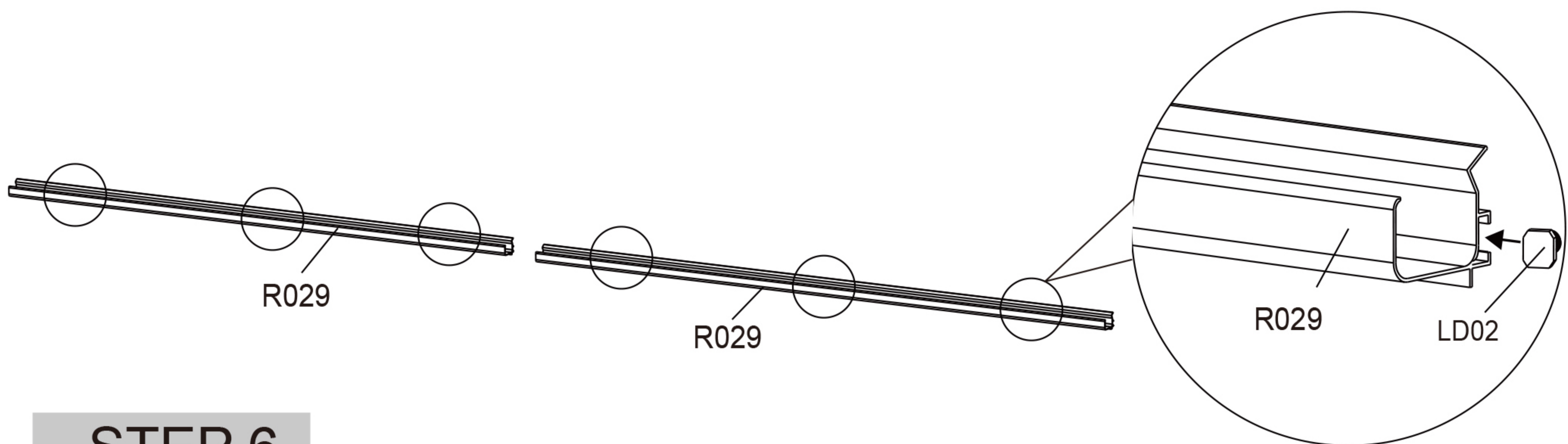

STEP 6

LM01*12

Adjust the position of the bolts to align the bolts with the holes and ensure that the R029 installation position is symmetrical.

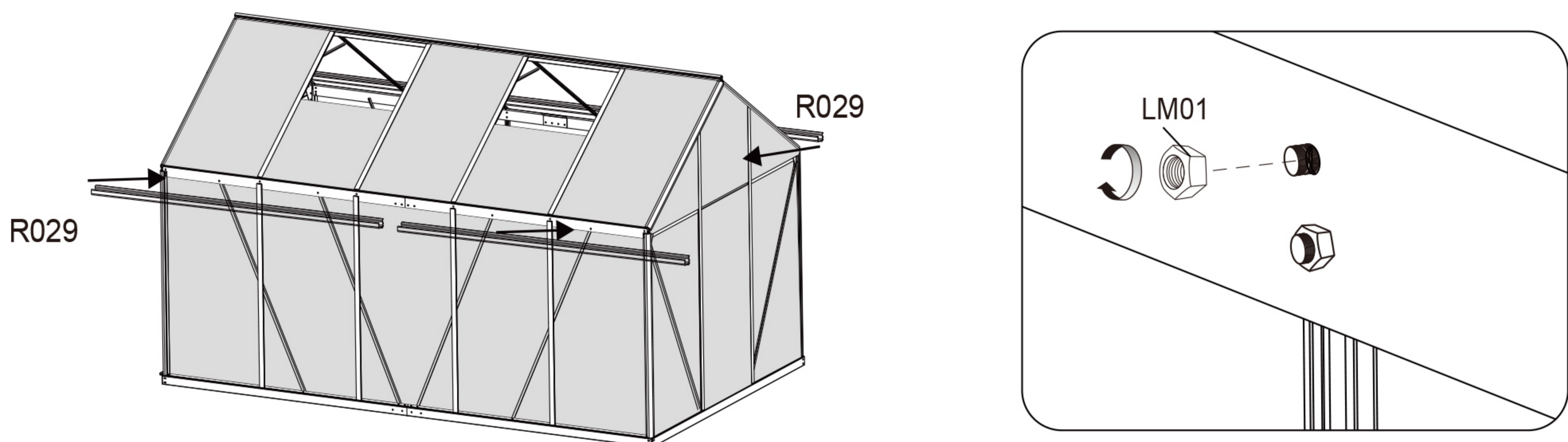

STEP 7







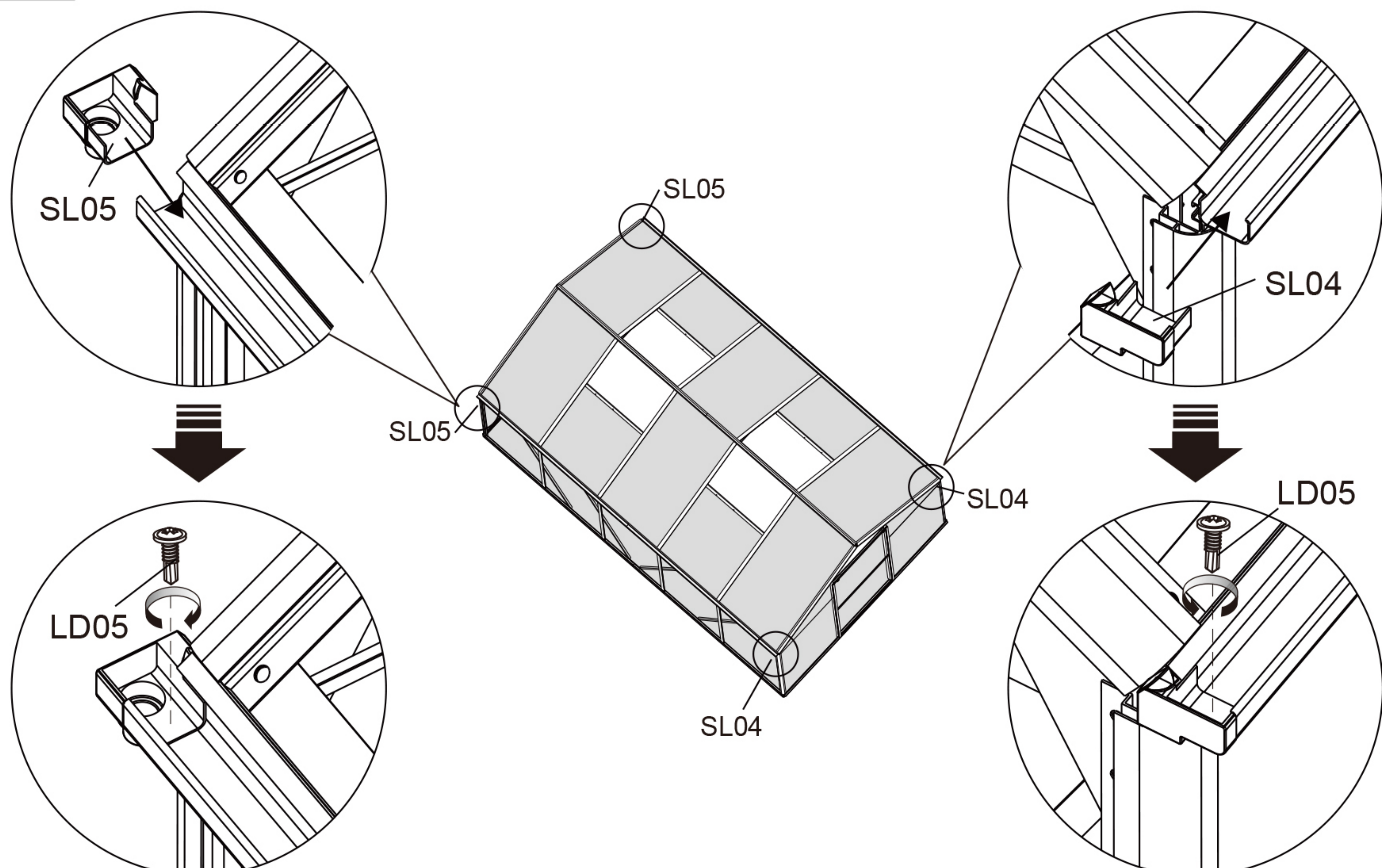

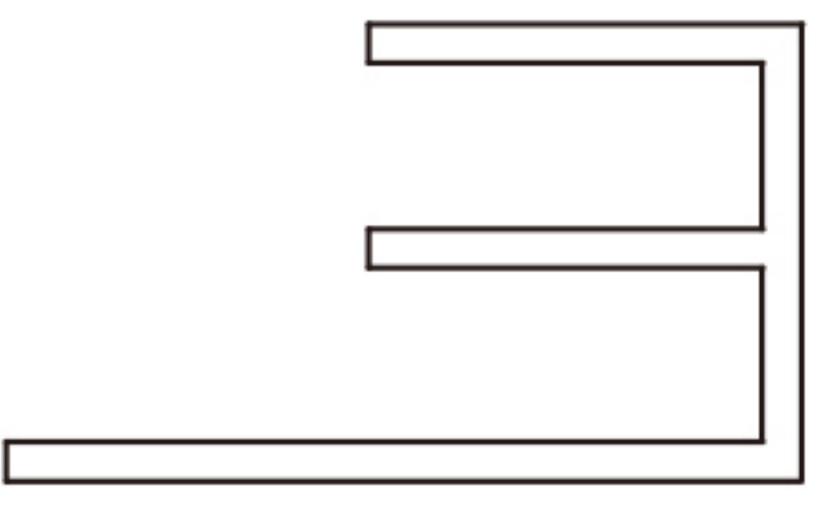

SL04*2

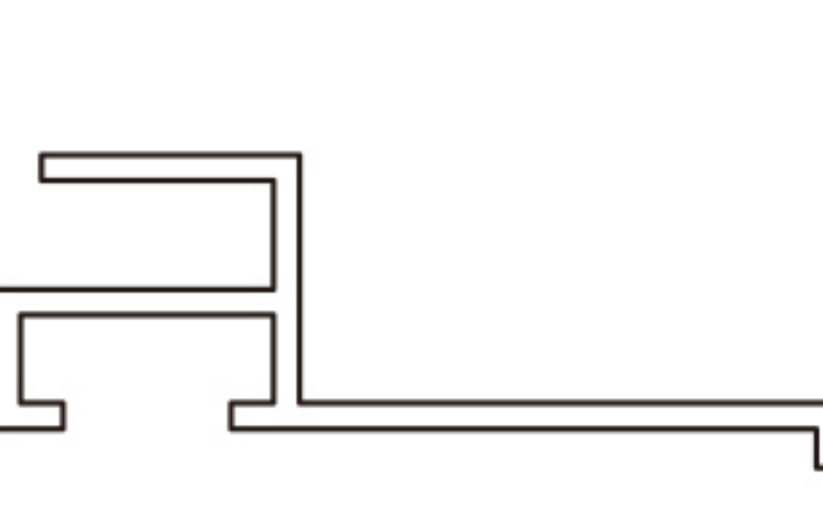
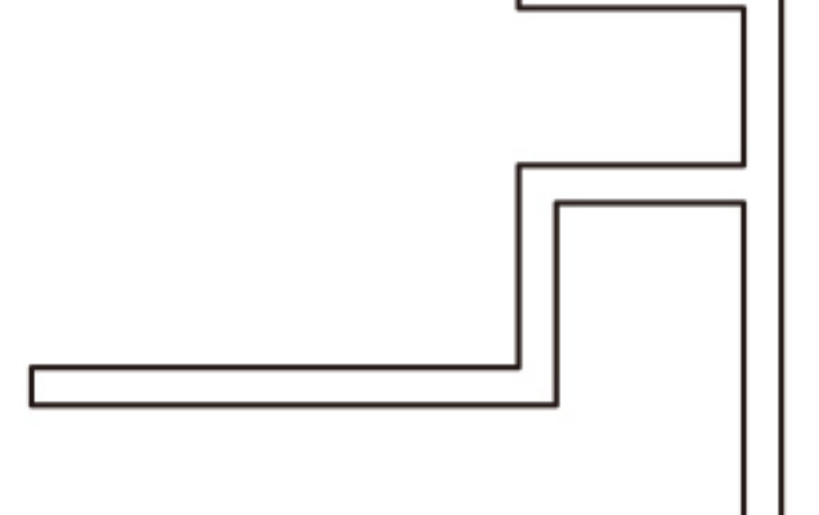
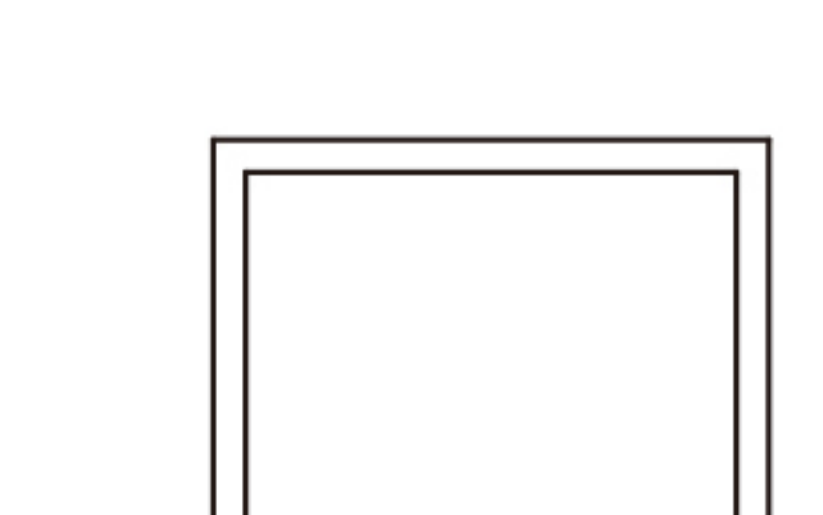
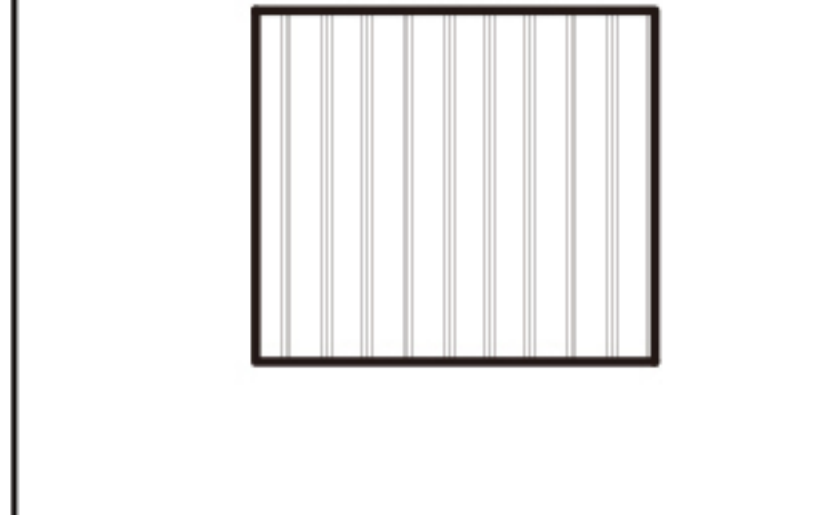
SL05*2

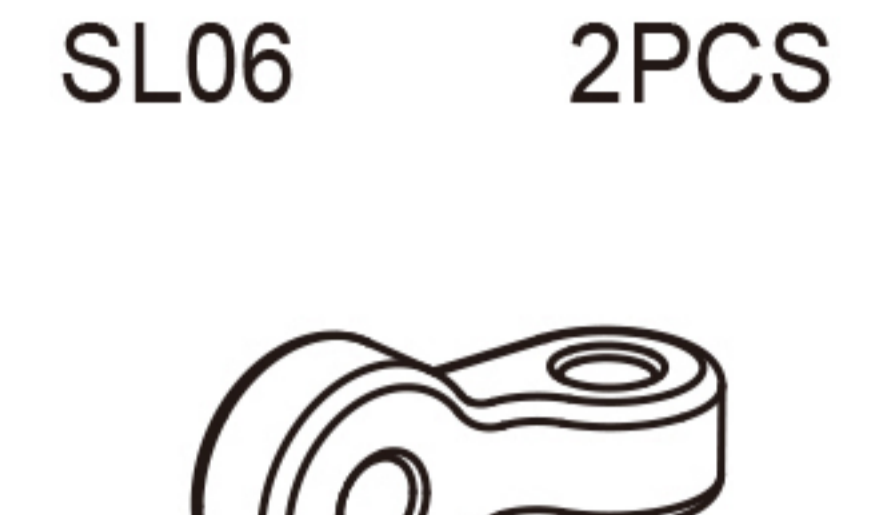
LD05*4

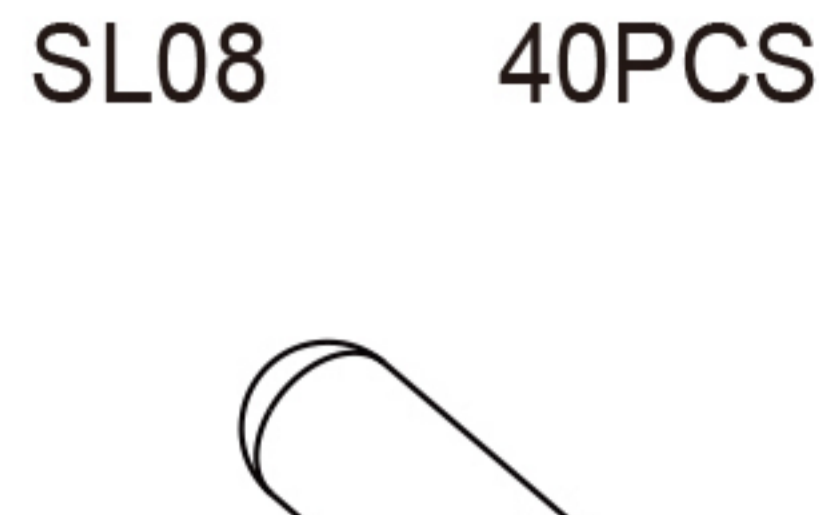

Vent Assembly

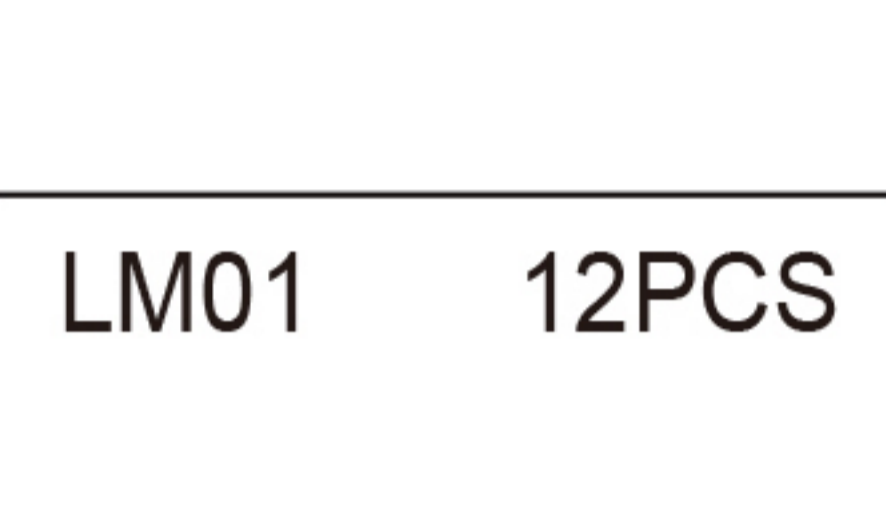
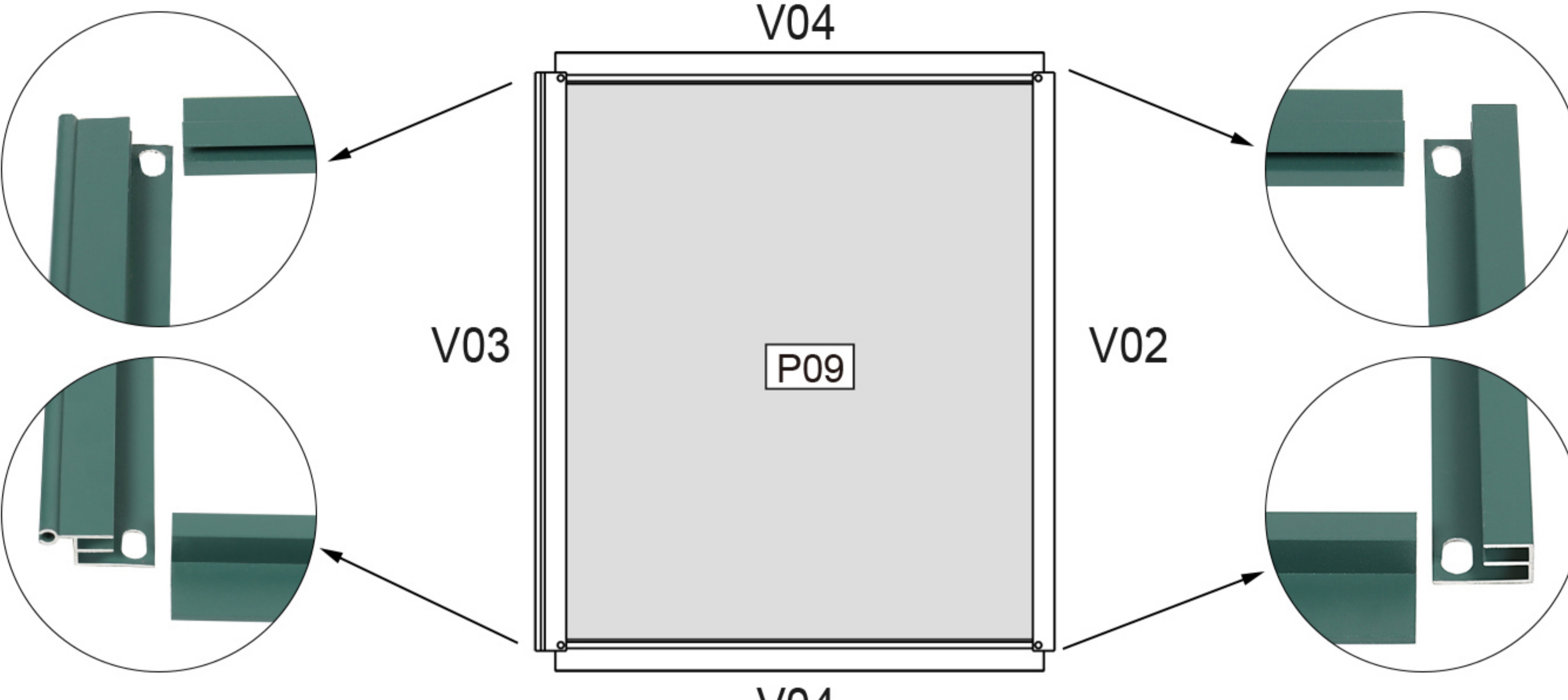
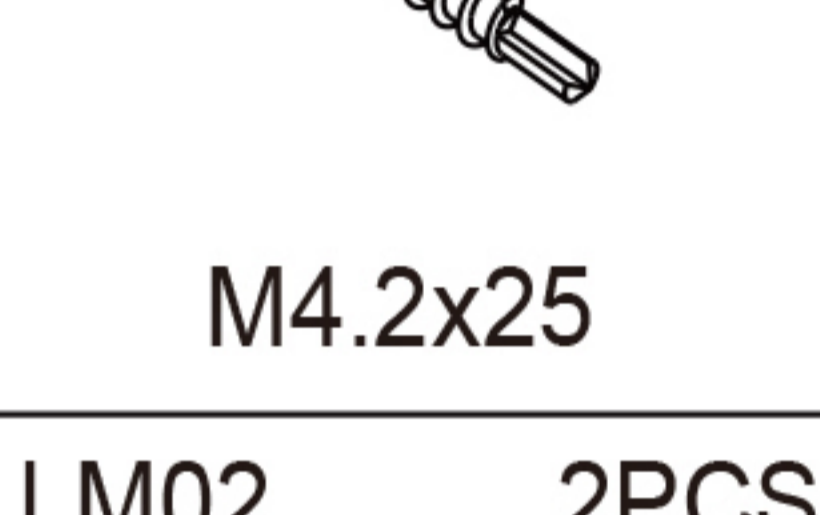
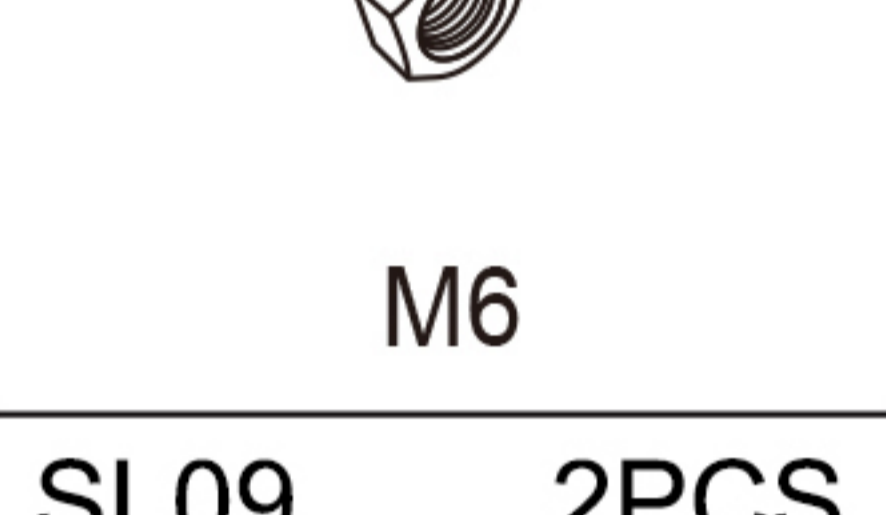
V02 2PCS 	V03 2PCS 	V04 4PCS 	V016 2PCS 	V017 2PCS 	P09 2PCS  20.4"x23"x0.16"
SL01 2PCS 	SL06 2PCS 	SL07 40PCS 	SL08 40PCS 	LD02 8PCS  M6x12	LD04 4PCS  M4x15
LD06 40PCS  M4.2x25	LM01 12PCS  M6				
LM02 2PCS  M4	SL09 2PCS 				

STEP 1

- V03*1
- V04*2
- LD02*6
- LM01*2

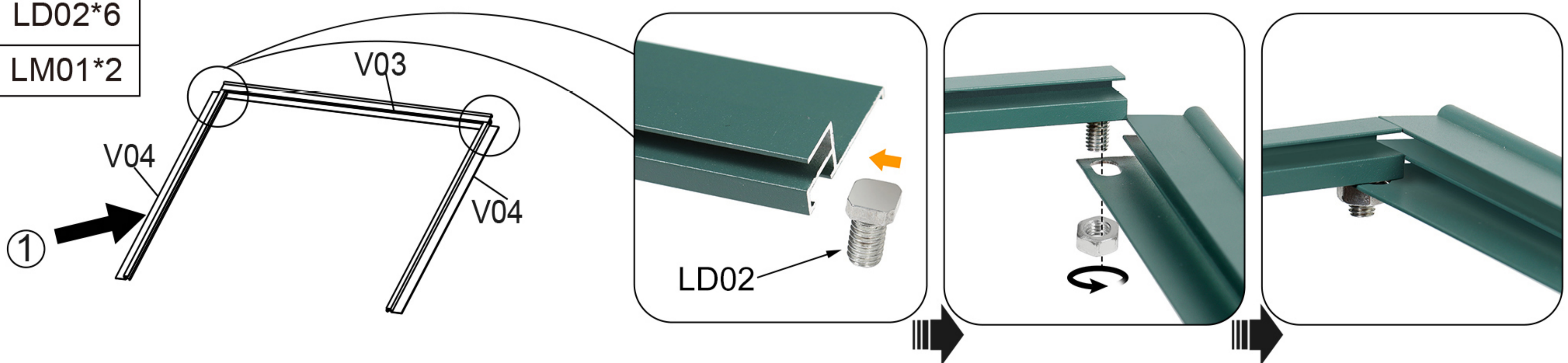

STEP 2

- P09*1

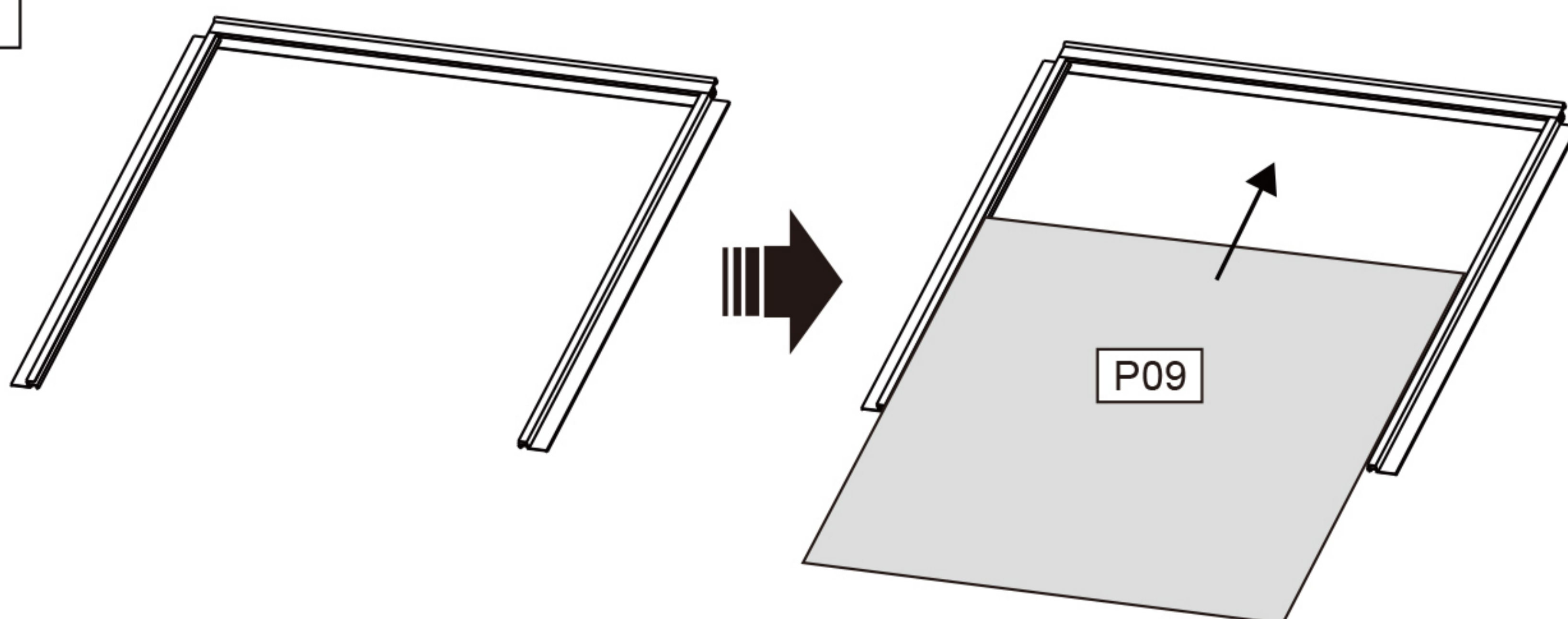

The clear film needs to be exposed to sunlight

STEP 3

- V02*1
- LD02*2
- LM01*2

Connect V02 and V04 with the bolt LD02 in V04, and tighten with nuts.

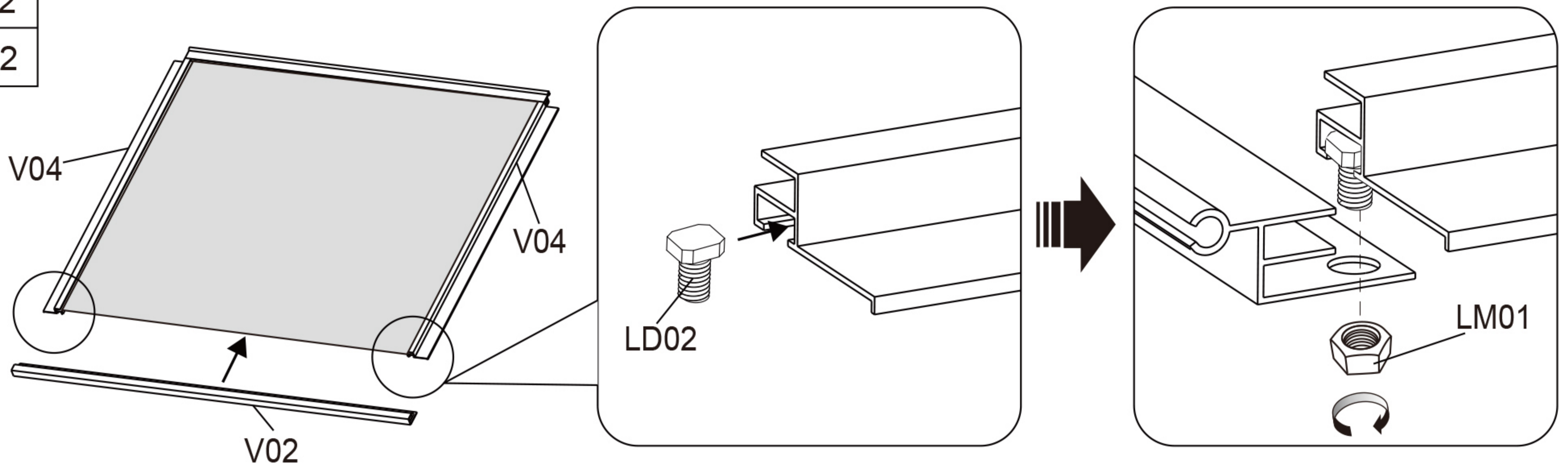

STEP 4

- V017*1
- SL06*1
- LD04*2
- LM02*2
- SL09*2

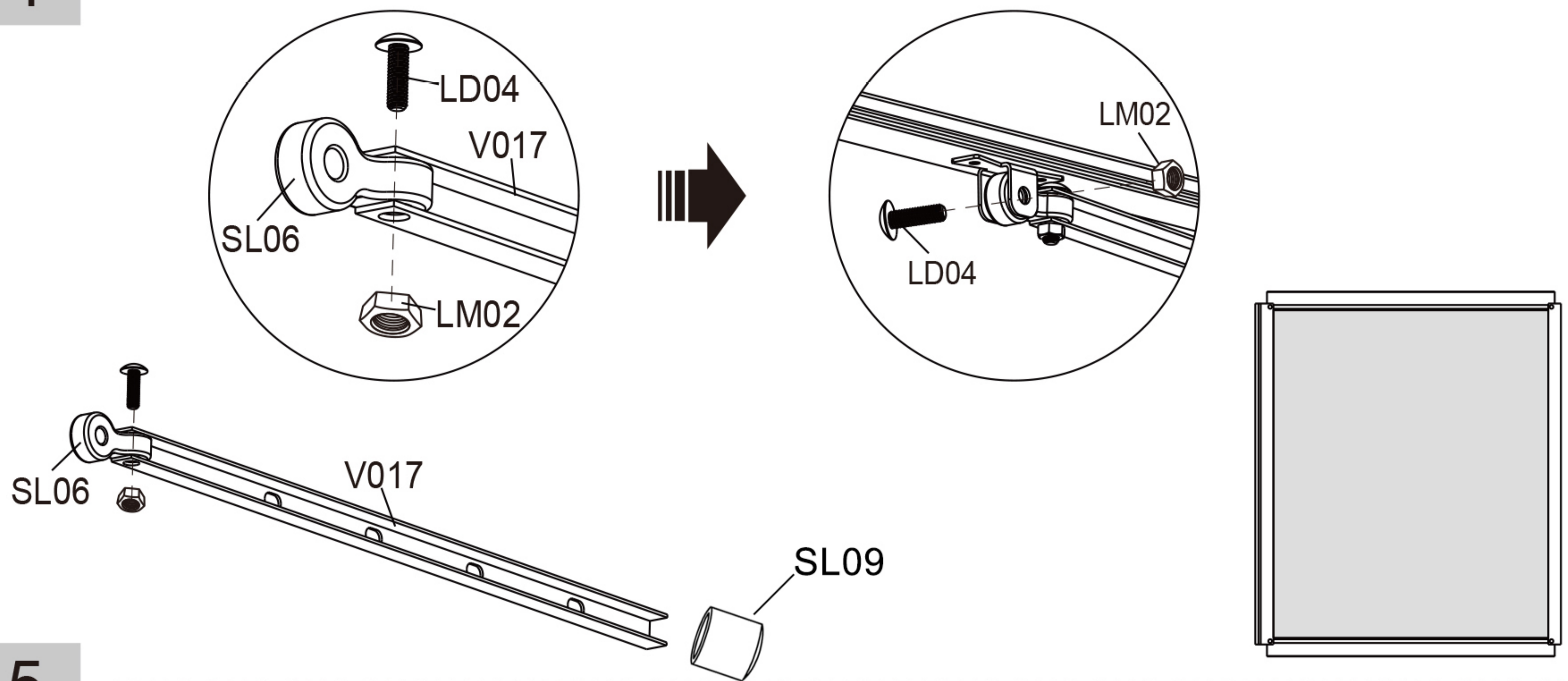

STEP 5

- V016*1
- LM01*2

Connect V016 with 1 pre-insert bolt LD02 in SG02, and tighten with nuts.

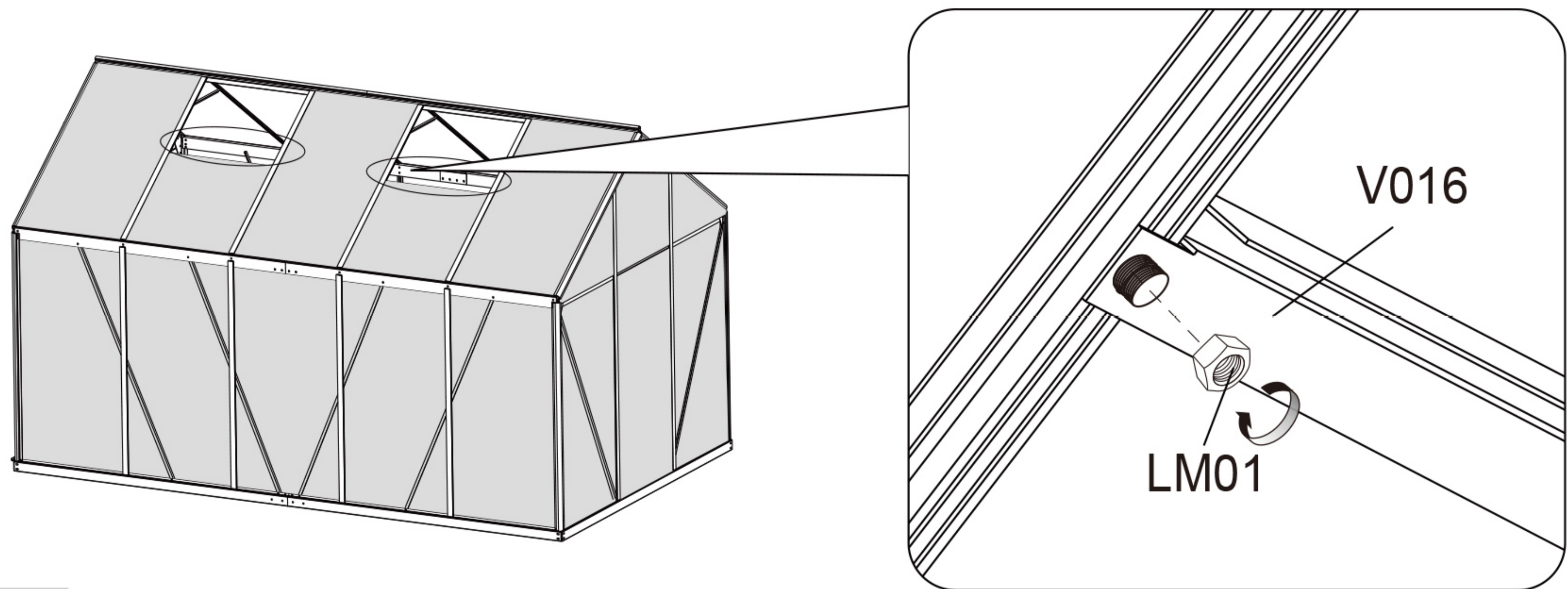

STEP 6

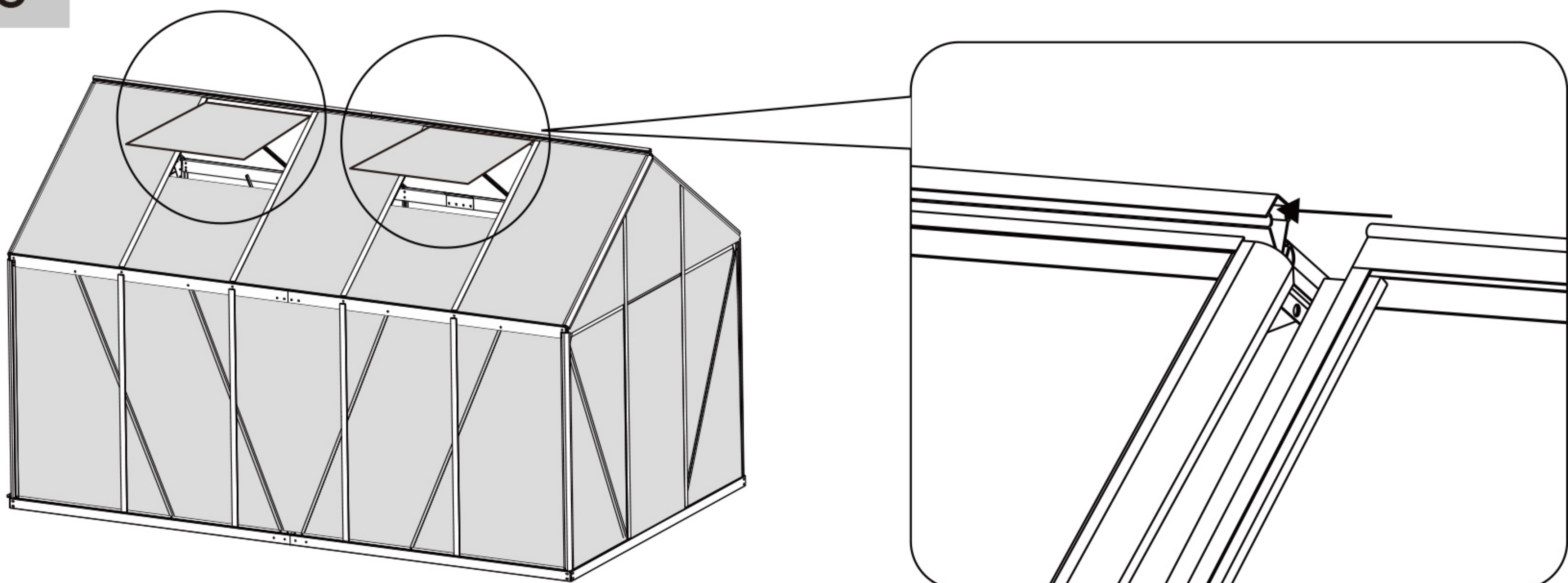

STEP 7

LD06*40

SL07*40

SL08*40

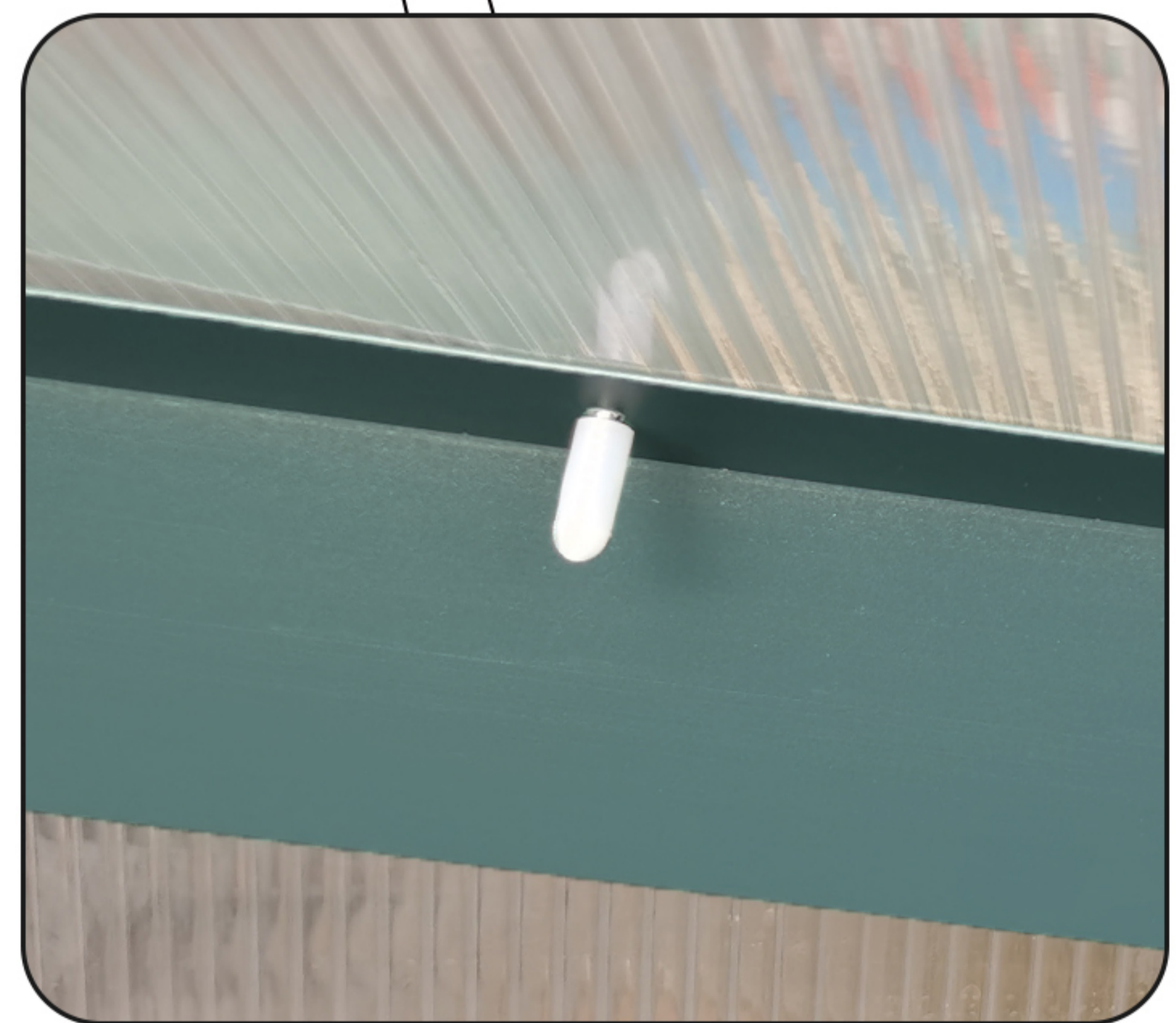
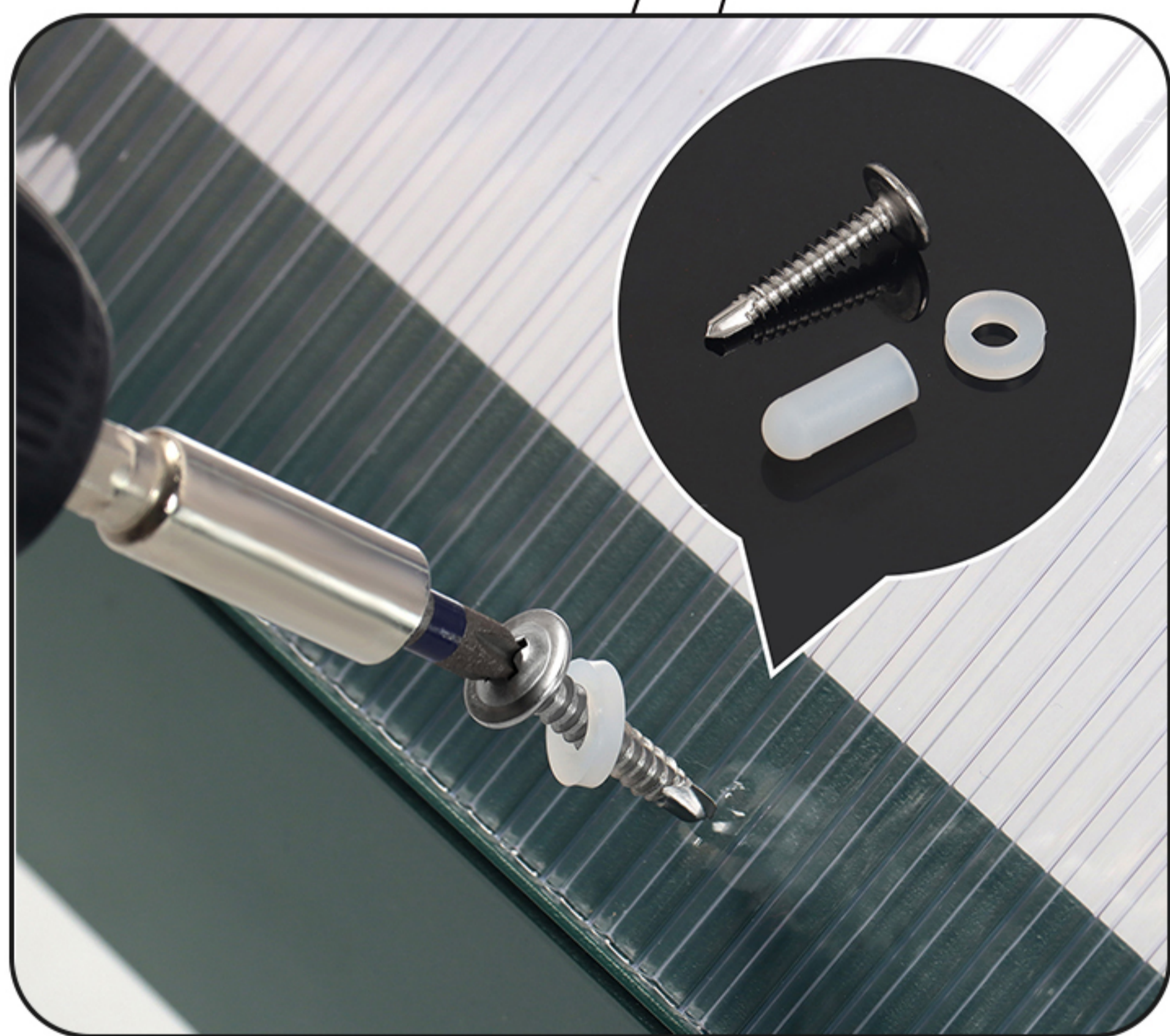
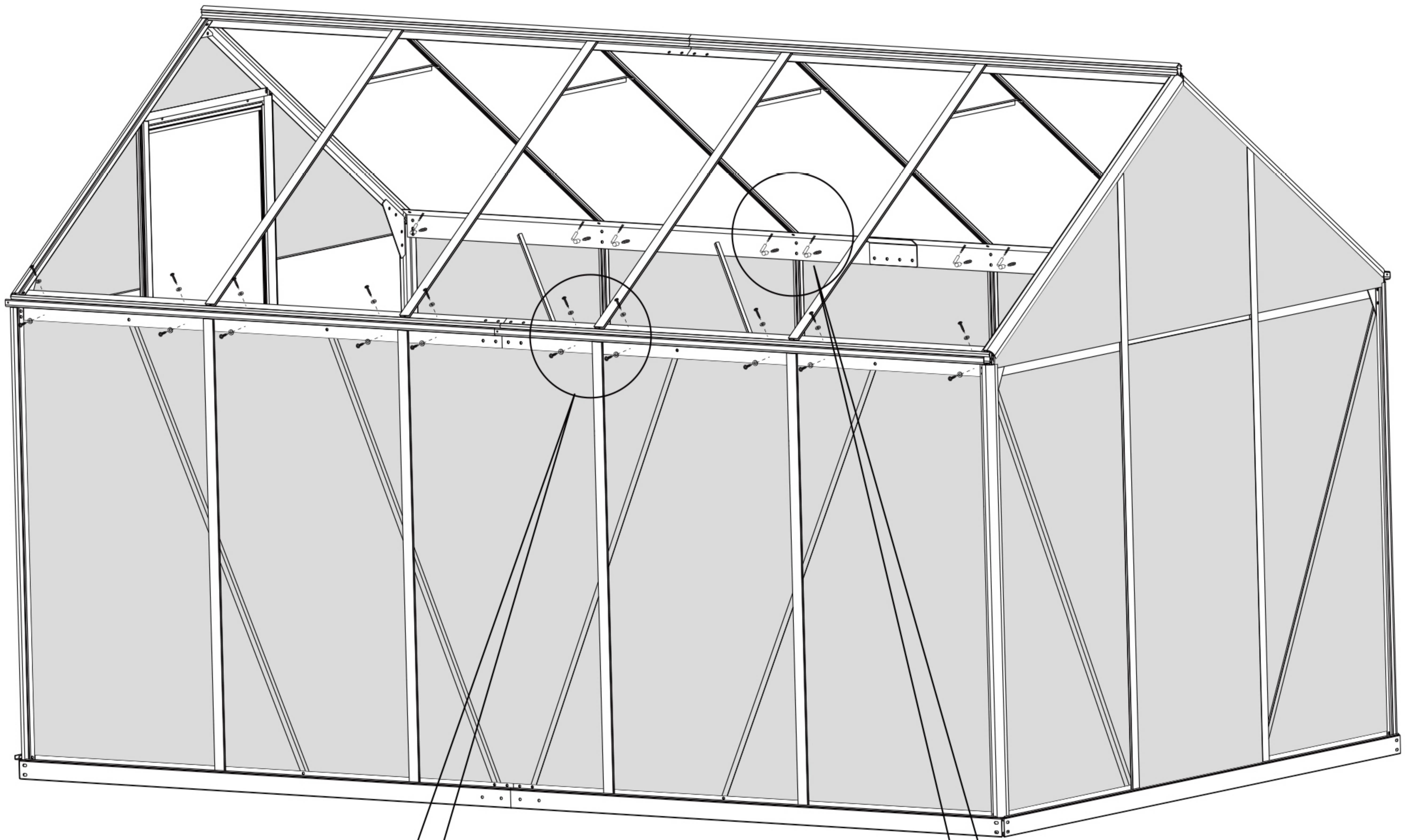





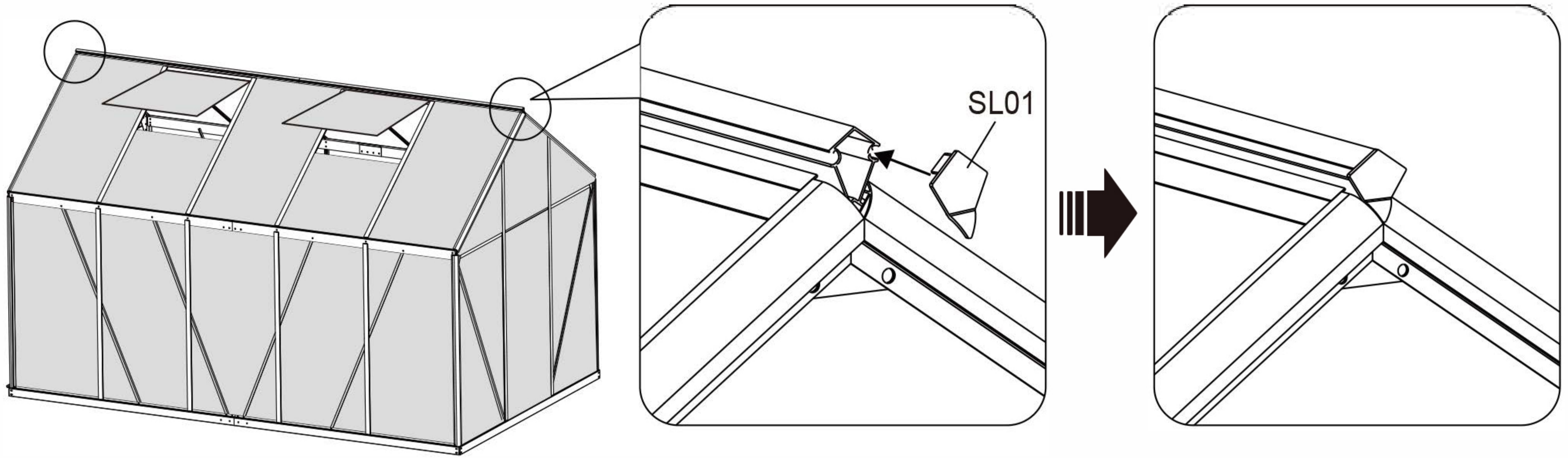



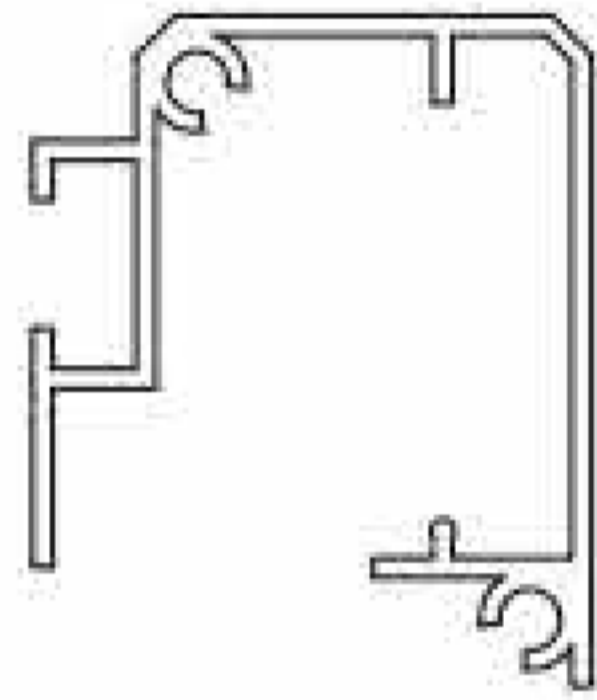

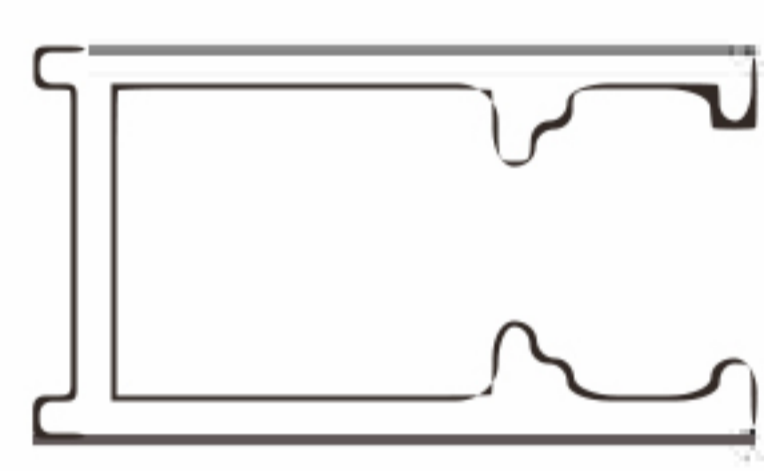
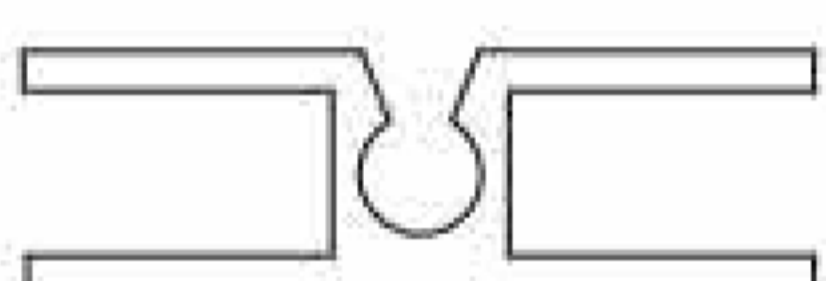
STEP 8

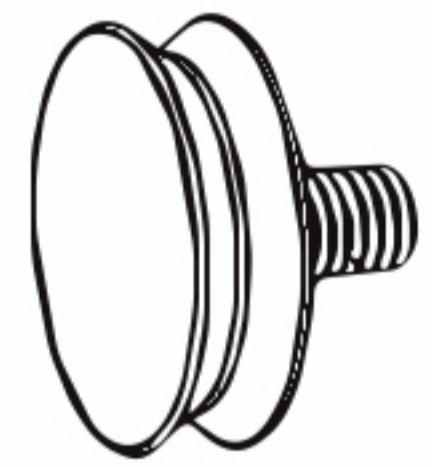
SL01*2



Door Assembly

D01 1PC 	D02 1PC 	D03 2PCS 	D04 2PCS 	P06 2PCS 30.7"x24.5"x0.16" 	
GL01 2PCS 	TP01 2PCS 	CT01 2PCS 	LD02 2PCS M6x12 	LD03 10PCS ST3.5x25 	LM01 4PCS M6 

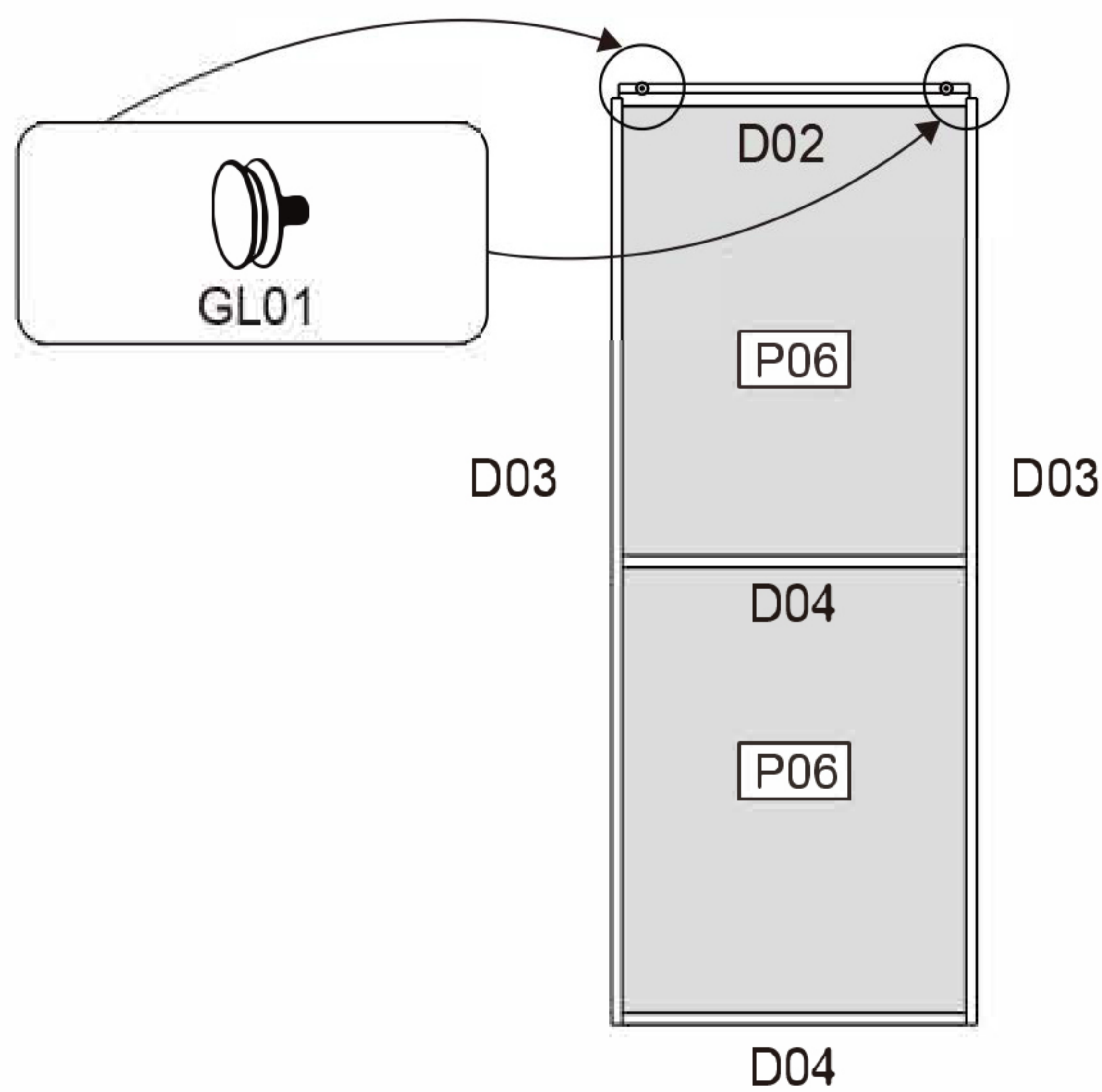

STEP 1

- D02*1
- D03*2
- LD03*2
- P06*1
- CT01*2

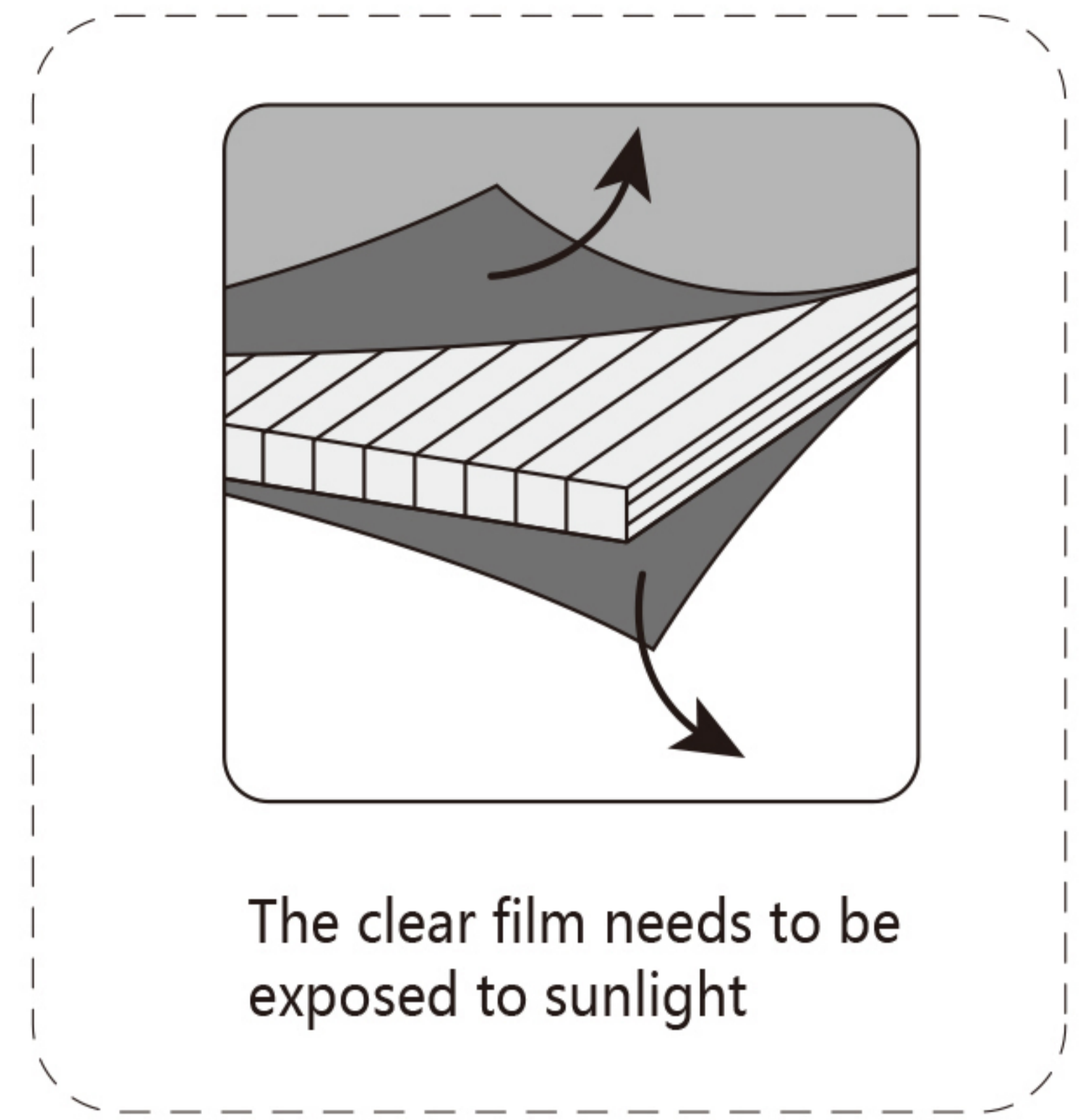
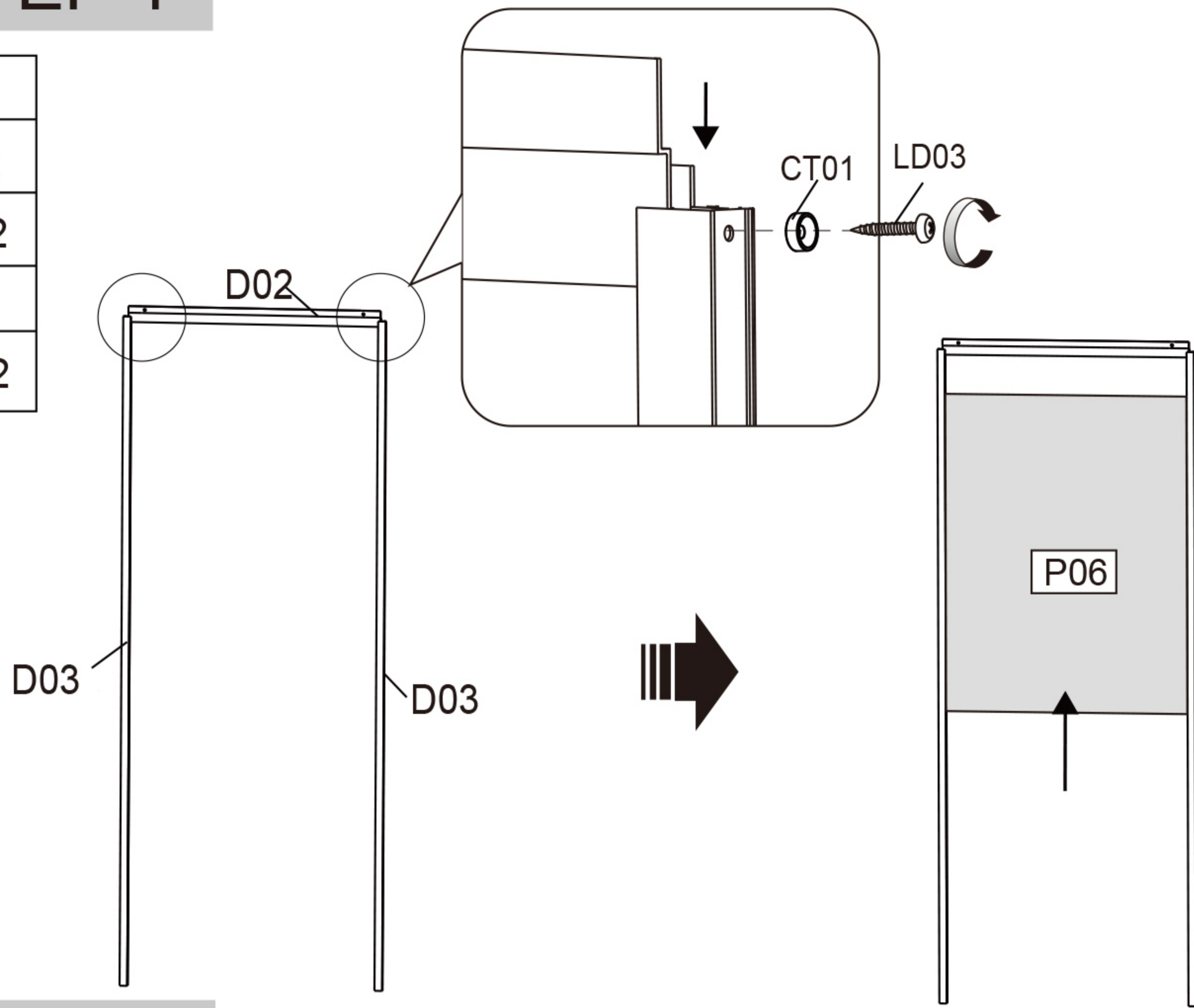

STEP 2

- D04*1
- LD03*2
- P06*1

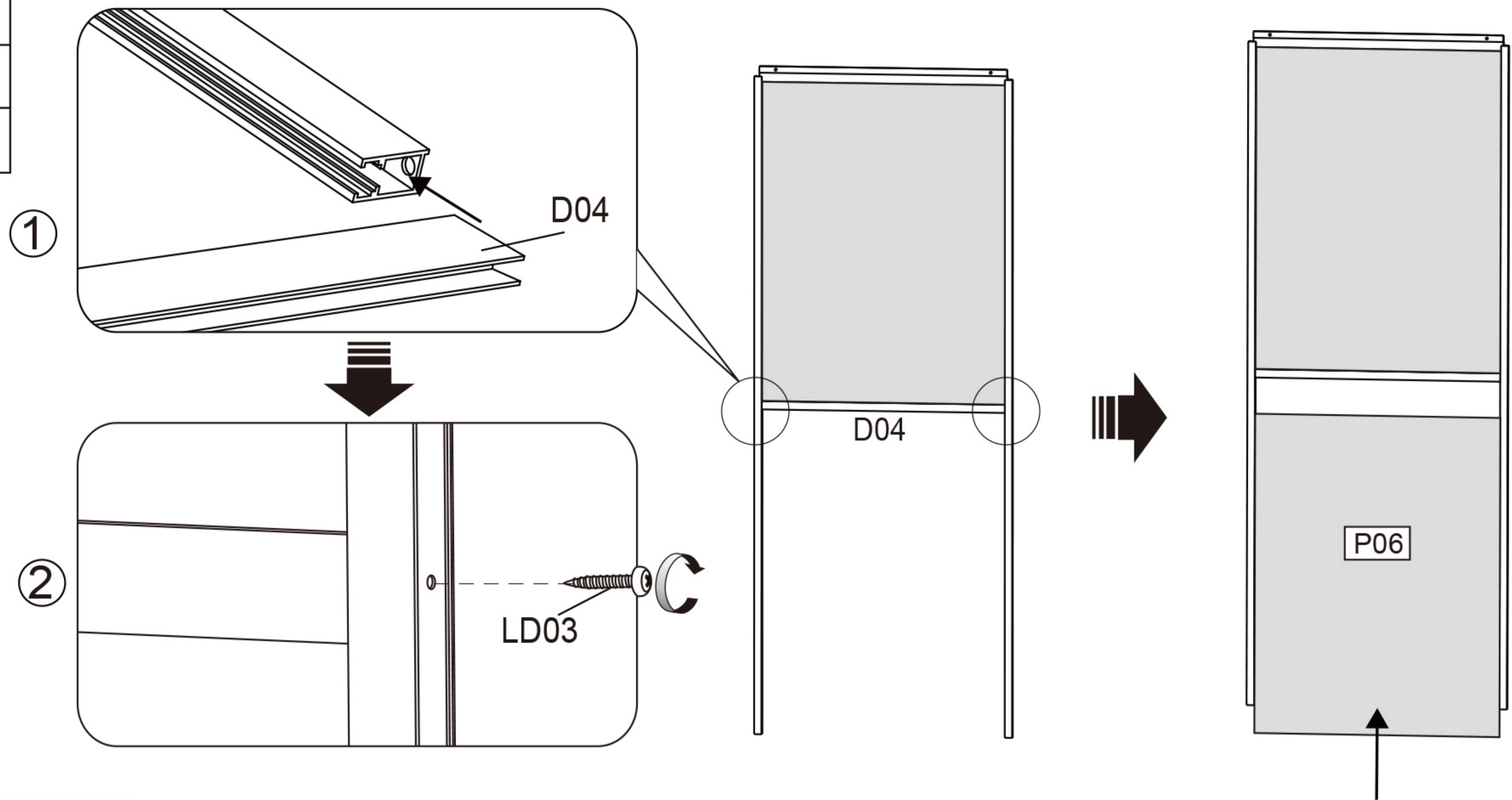

STEP 3

- D04*1
- LD03*2

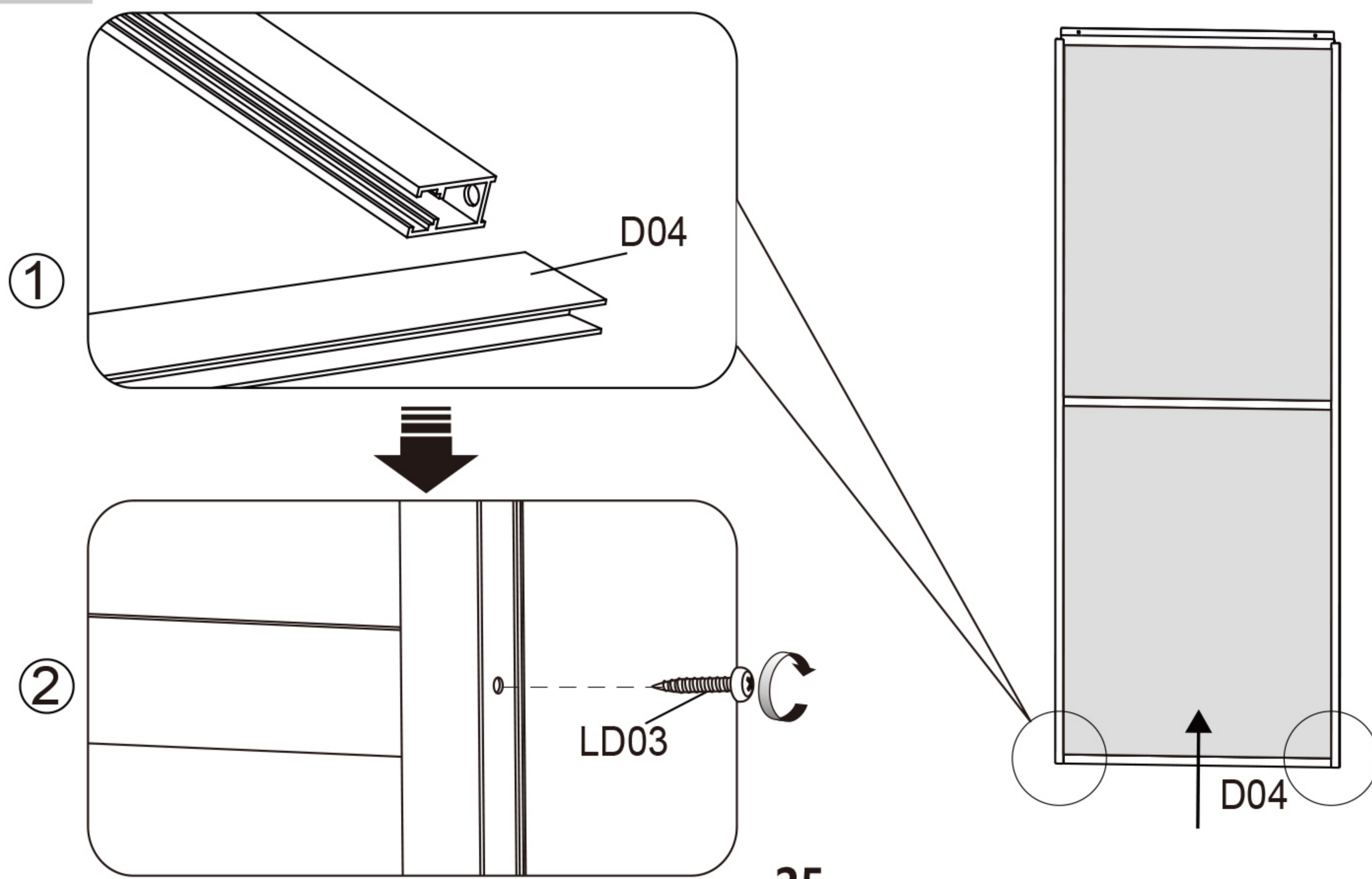

STEP 4

GL01*2

LM01*2

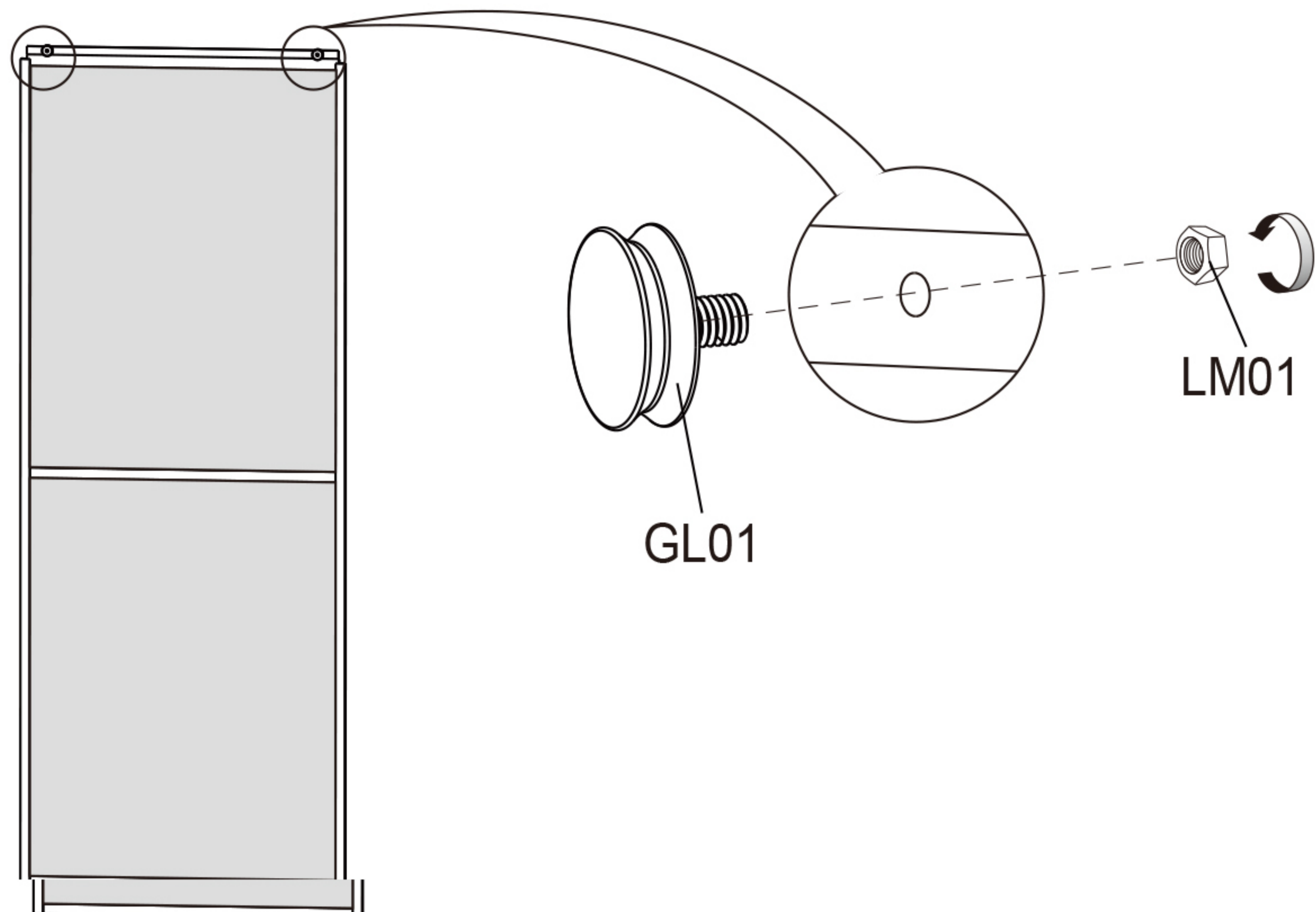

STEP 5

D01*1

LD02*2

LM01*2

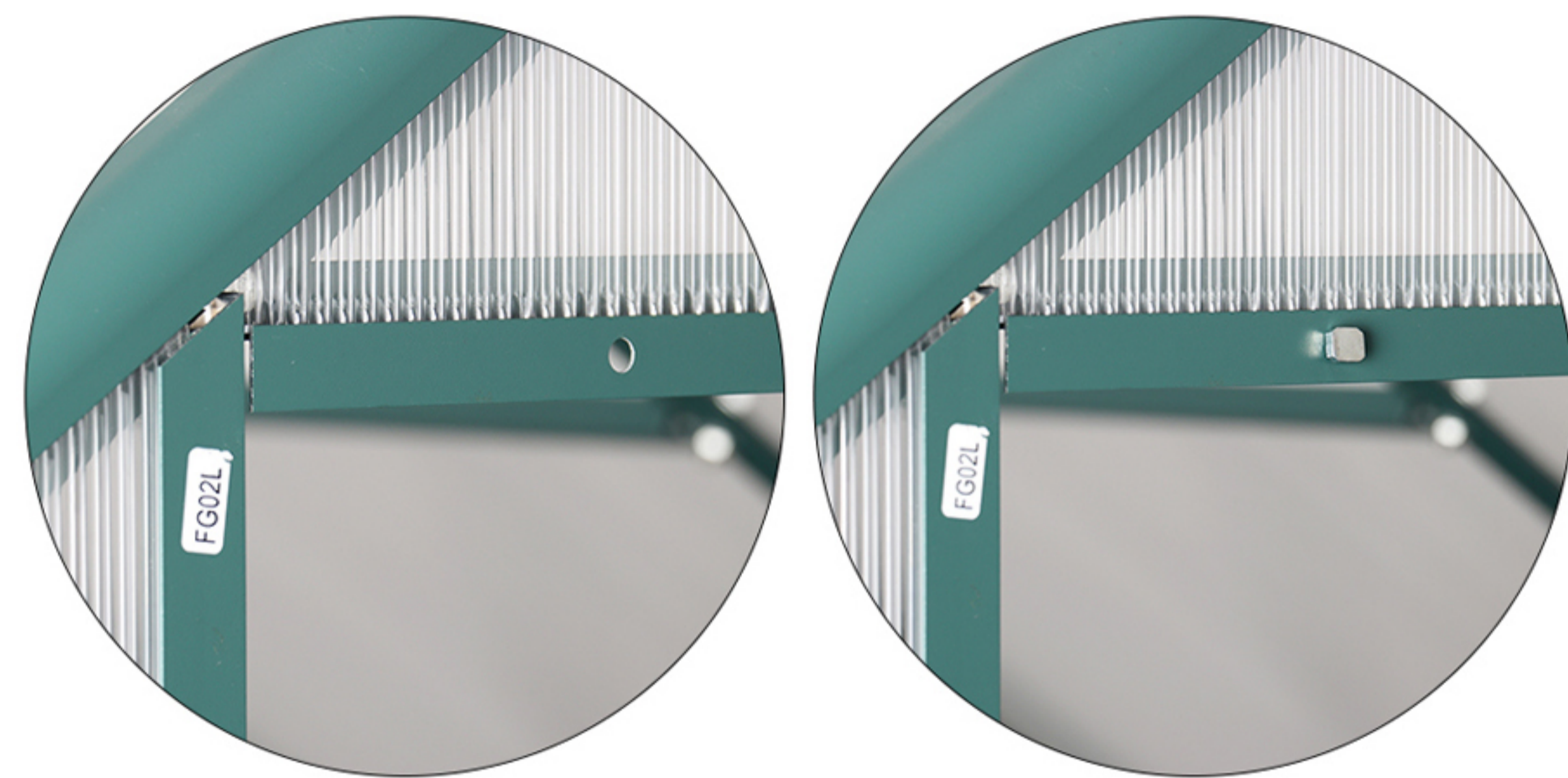
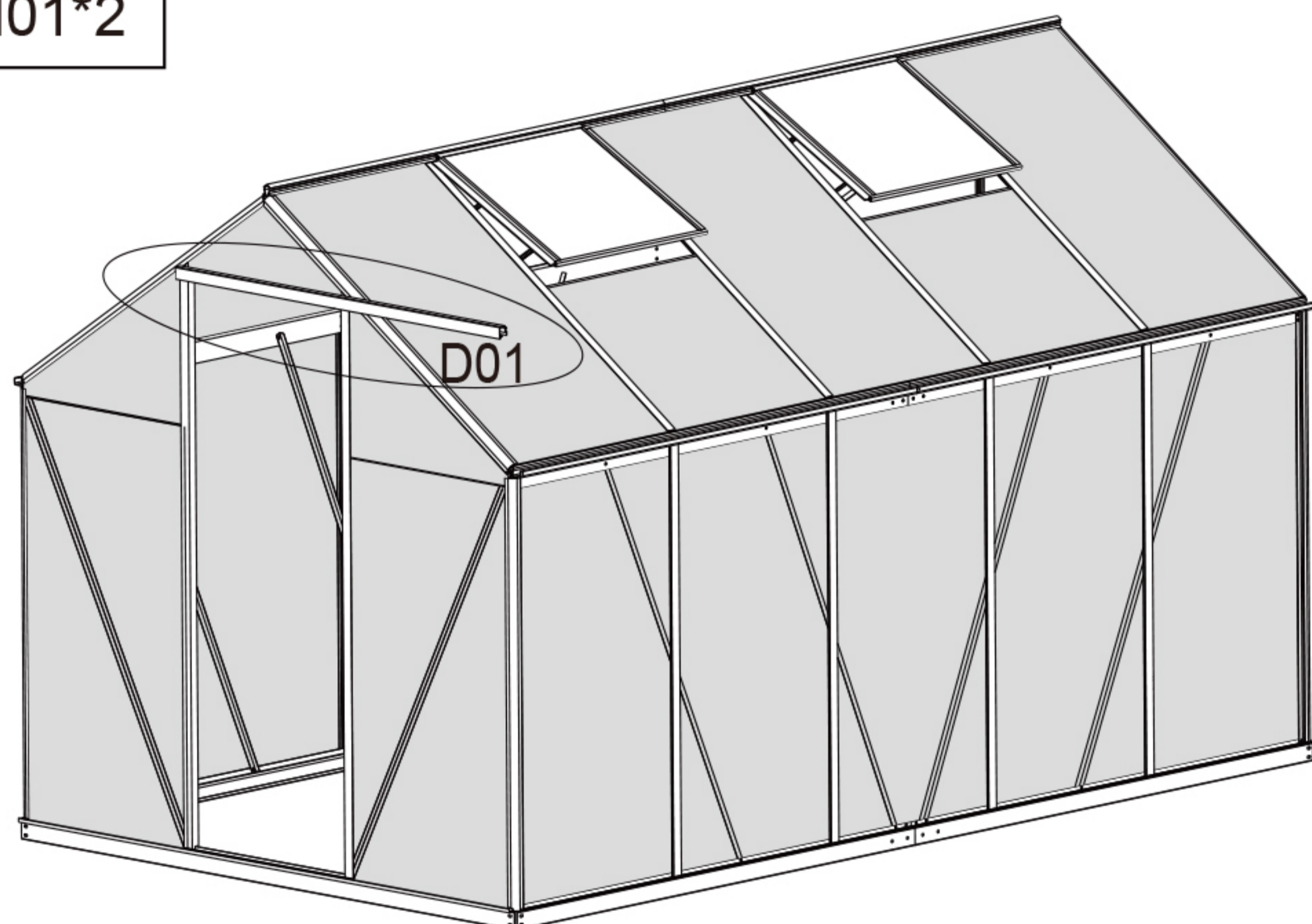

Insert two bolts in FG05. Don't tighten the nuts.

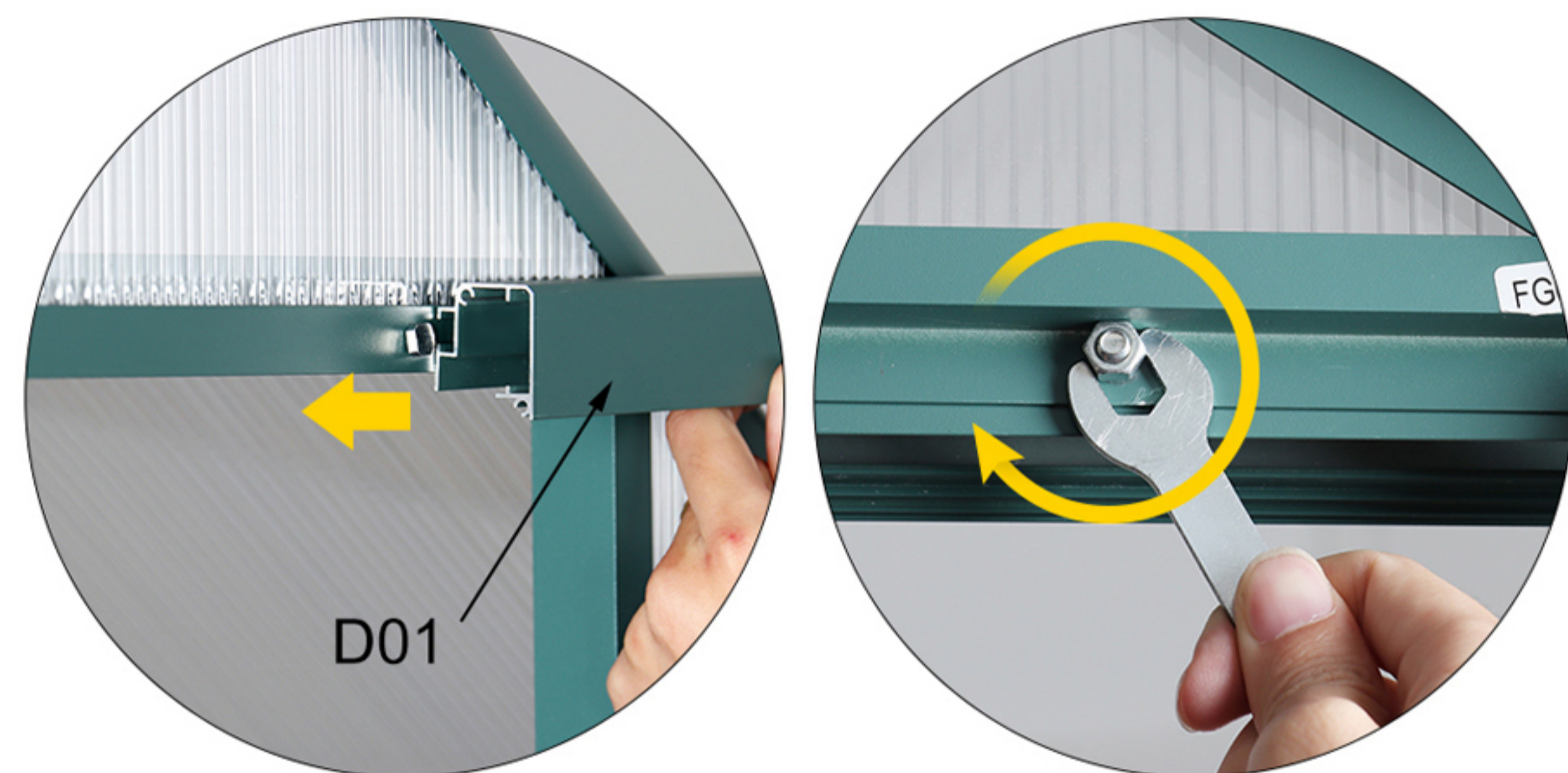

D01 can be installed on left or right.
Slide D01 through the screws on FG05, adjust the position to your needs, finally tighten the nuts.



Note: that Part D01 needs to be kept level so that the sliding door can slide smoothly. We suggest to measure its levelness after installing D01, and then move to the next step installation.

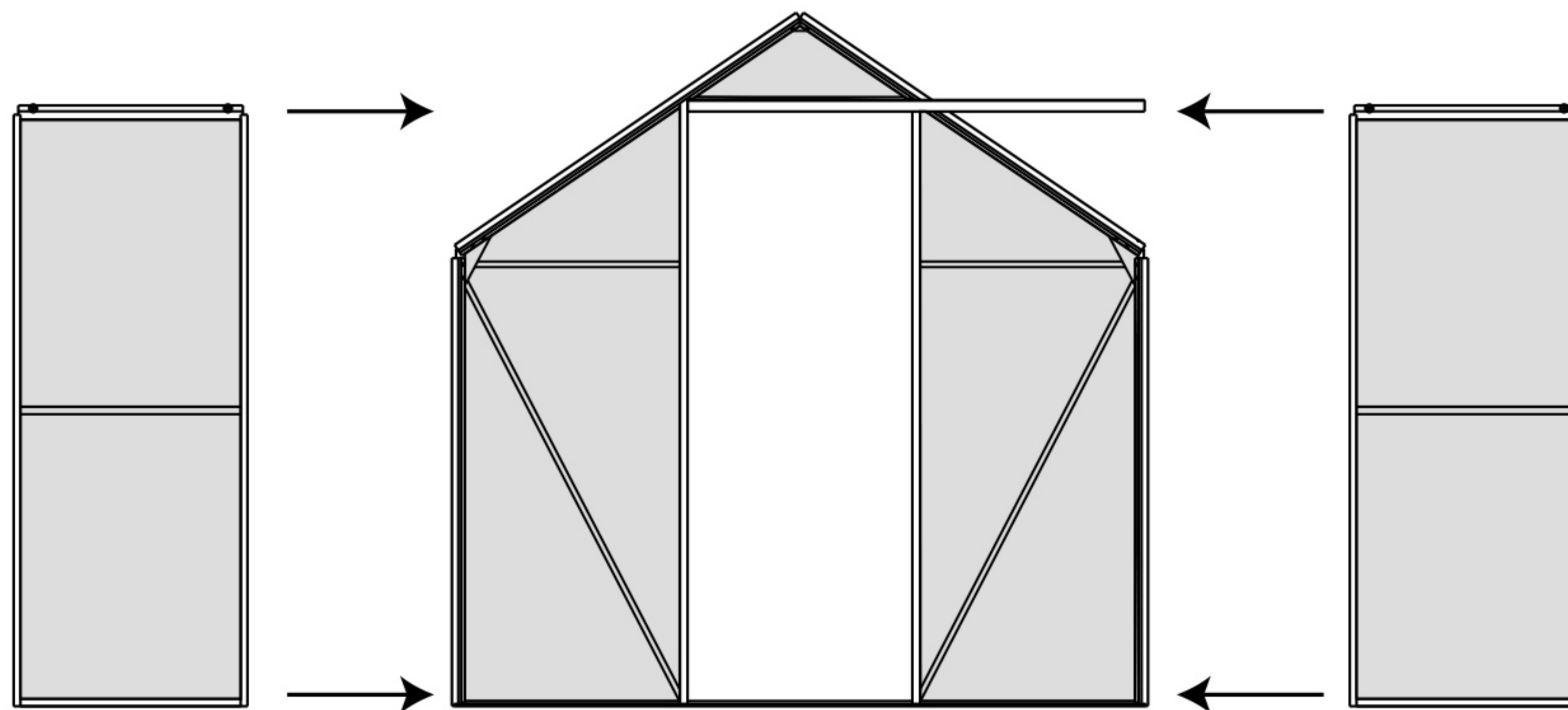
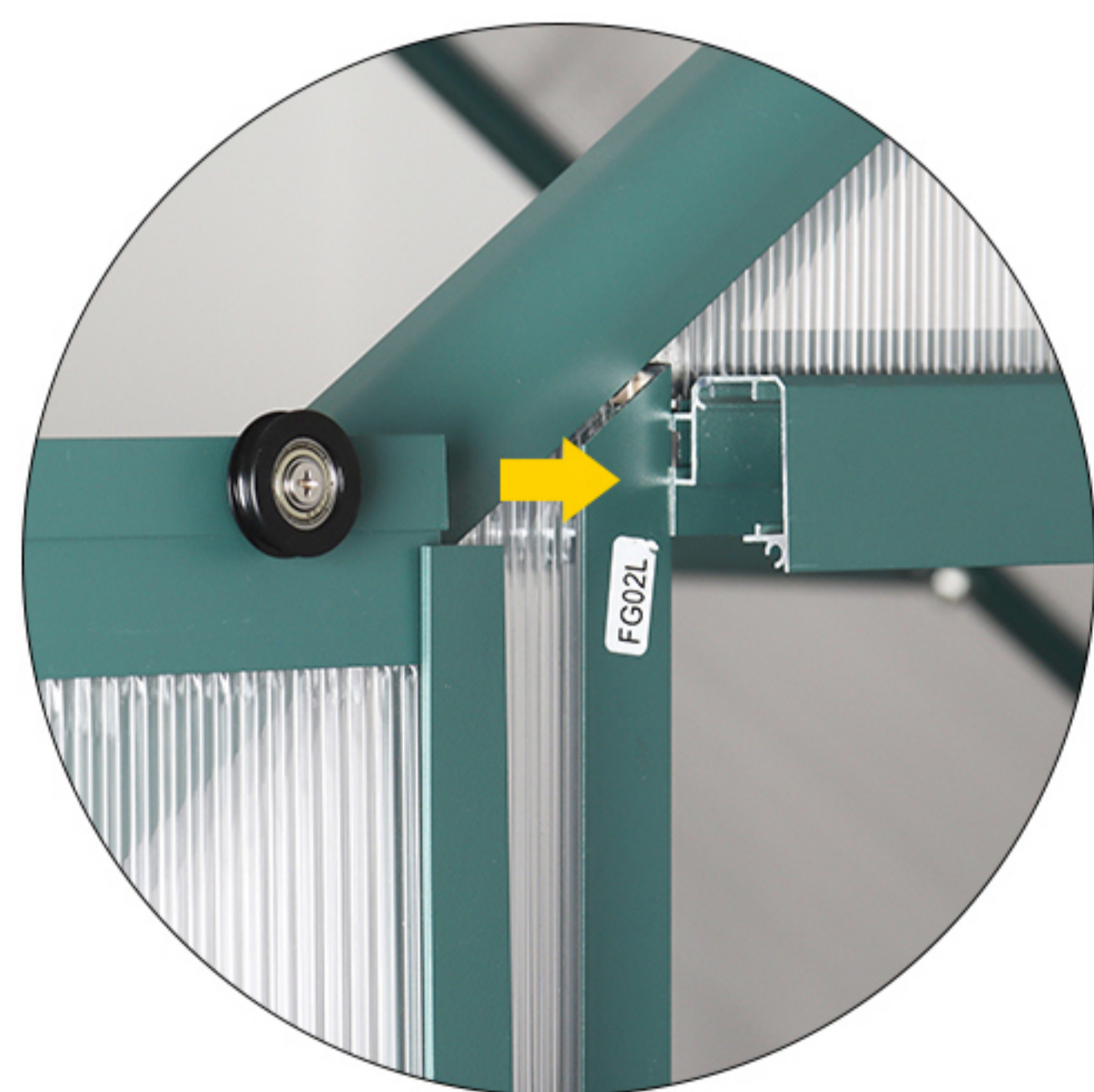

Slide the door in from either side of the D01.

STEP 6

LD03*4

TP01*2

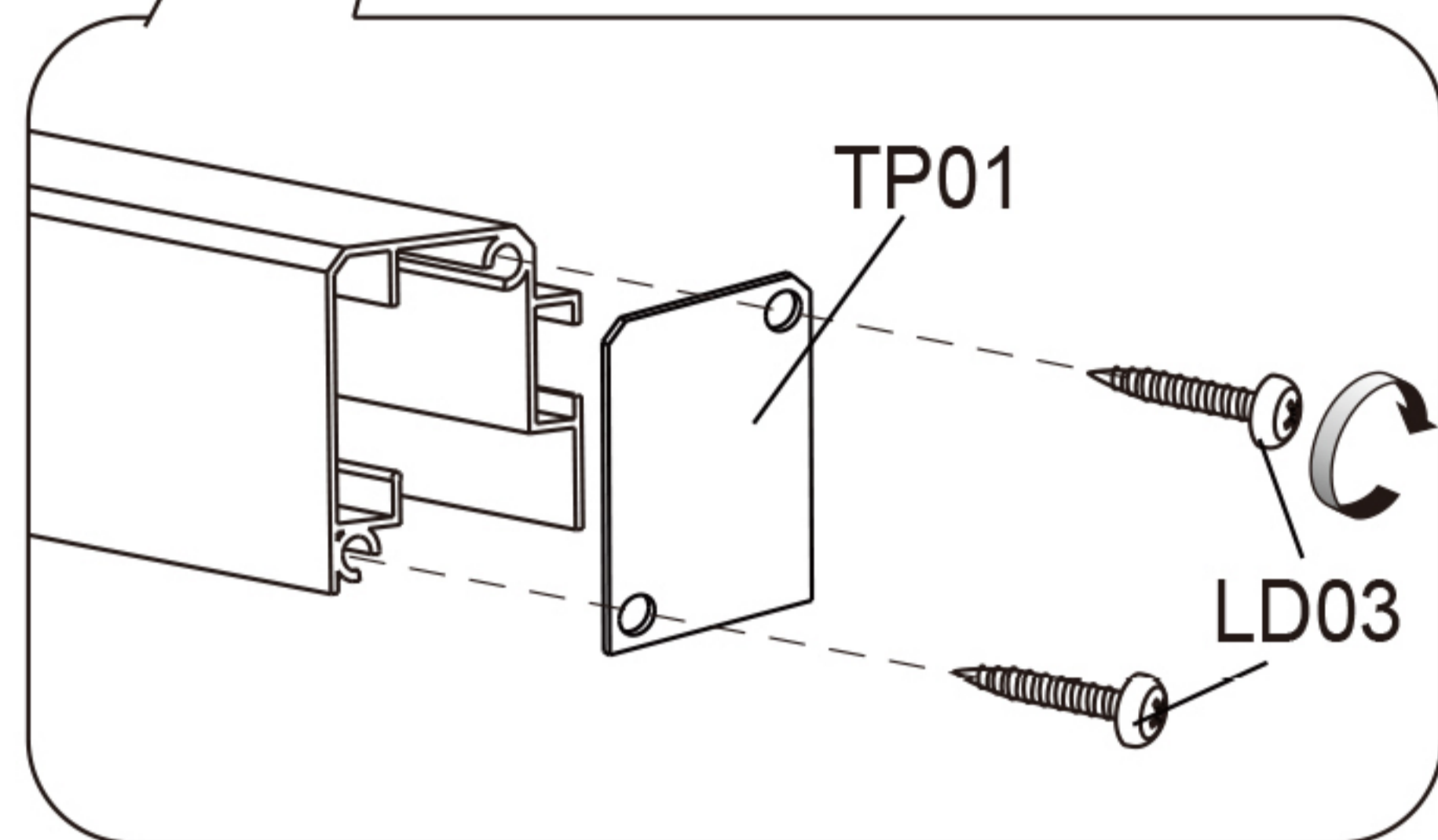
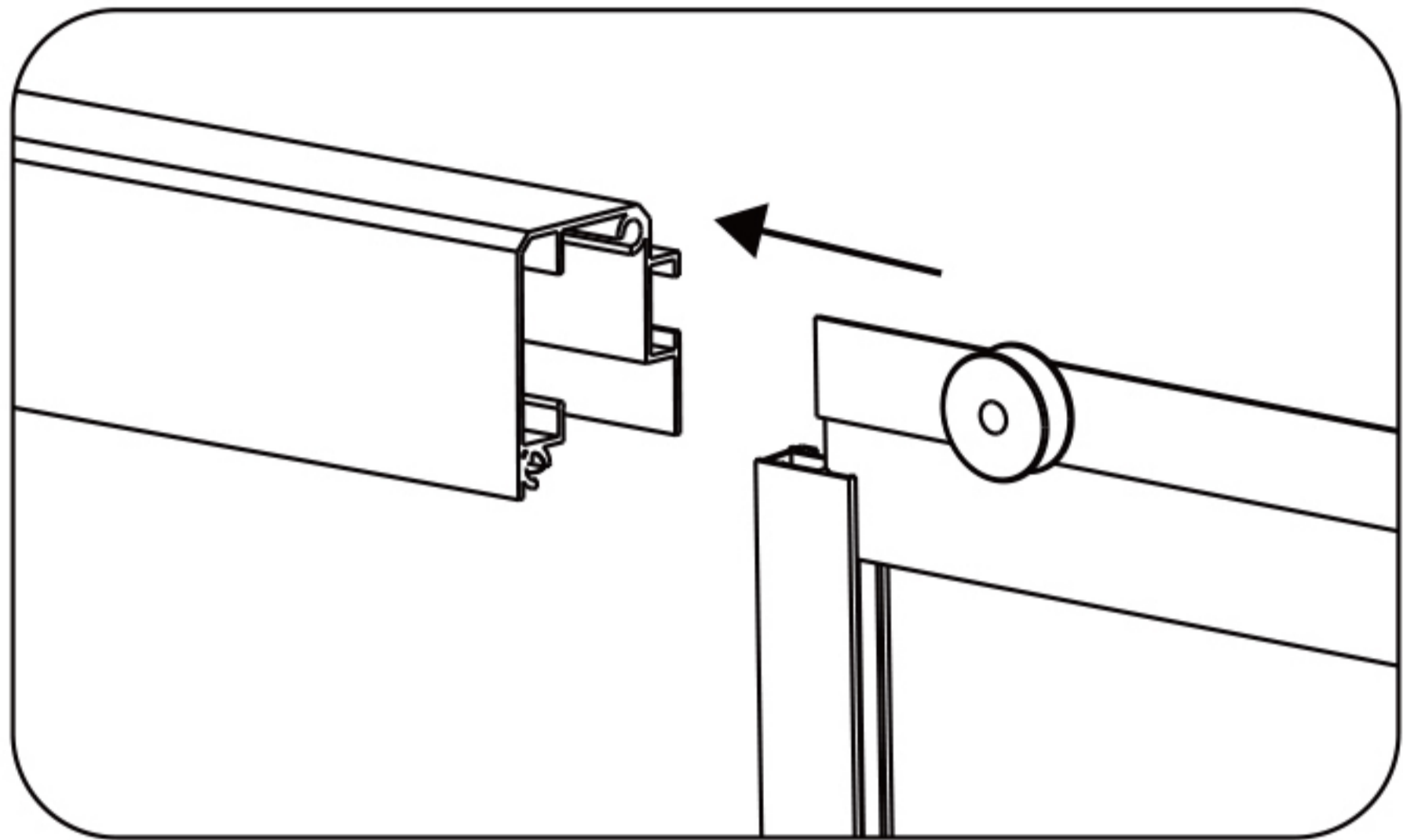
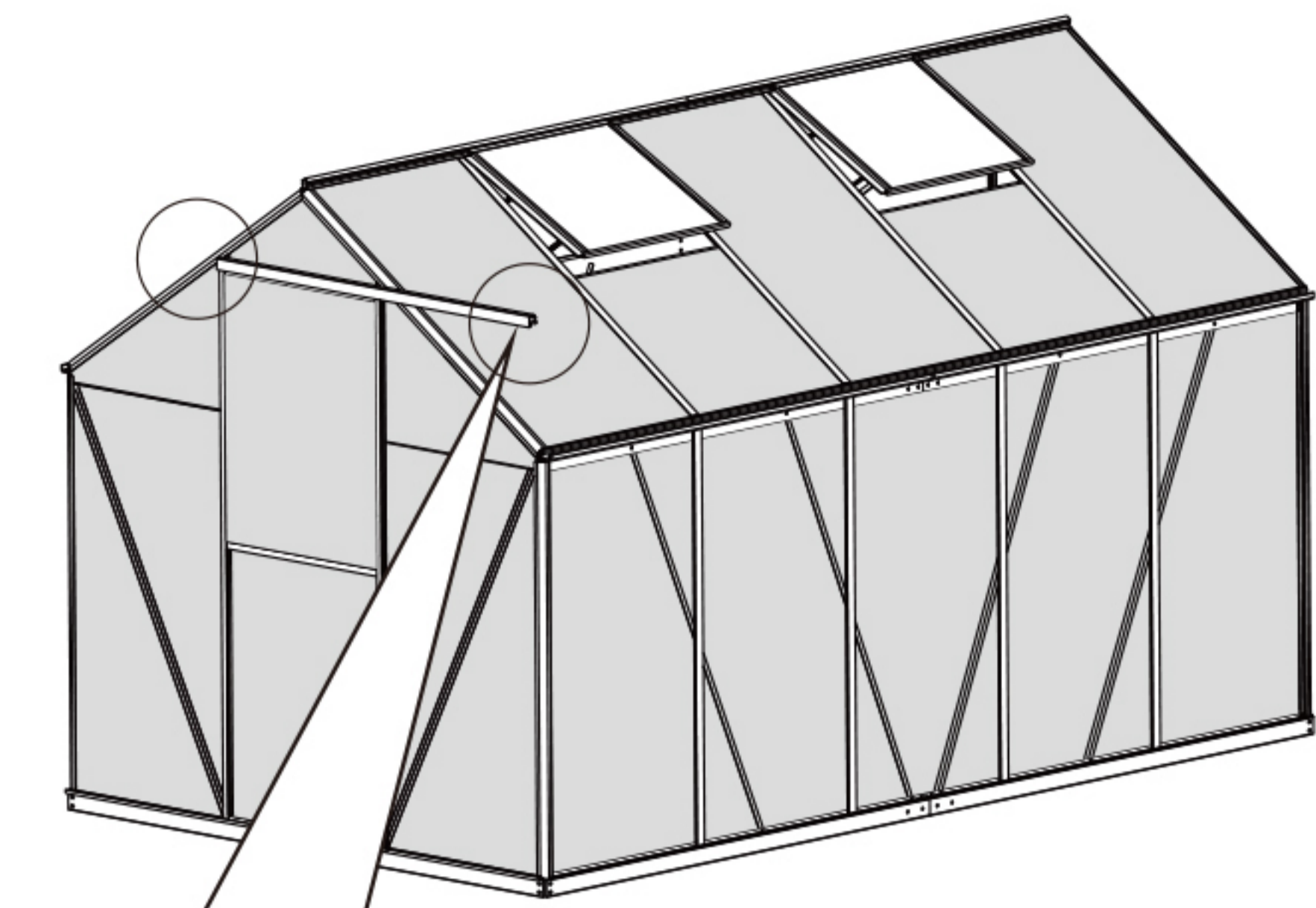
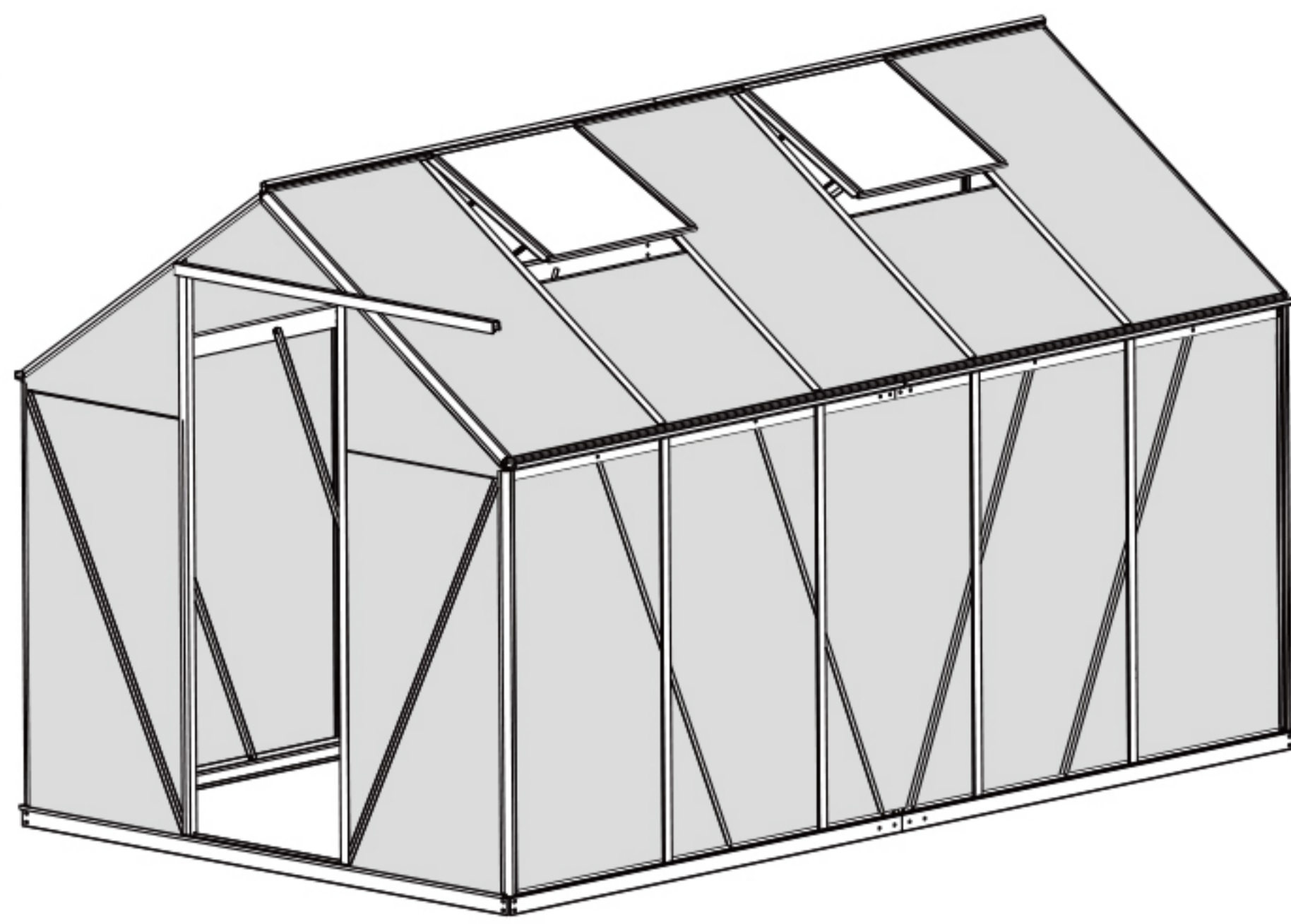

Base Assembly

B01	2PCS	B029	4PCS	BJ01	BJ02	LD02	LM01
				4PCS	2PCS	24PCS	24PCS

STEP 1

Connect B029 with the BJ02.

The head of LD02 bolt face outside, and tight the nut LM01 inside.

B029*4

BJ02*2

LD02*8

LM01*8

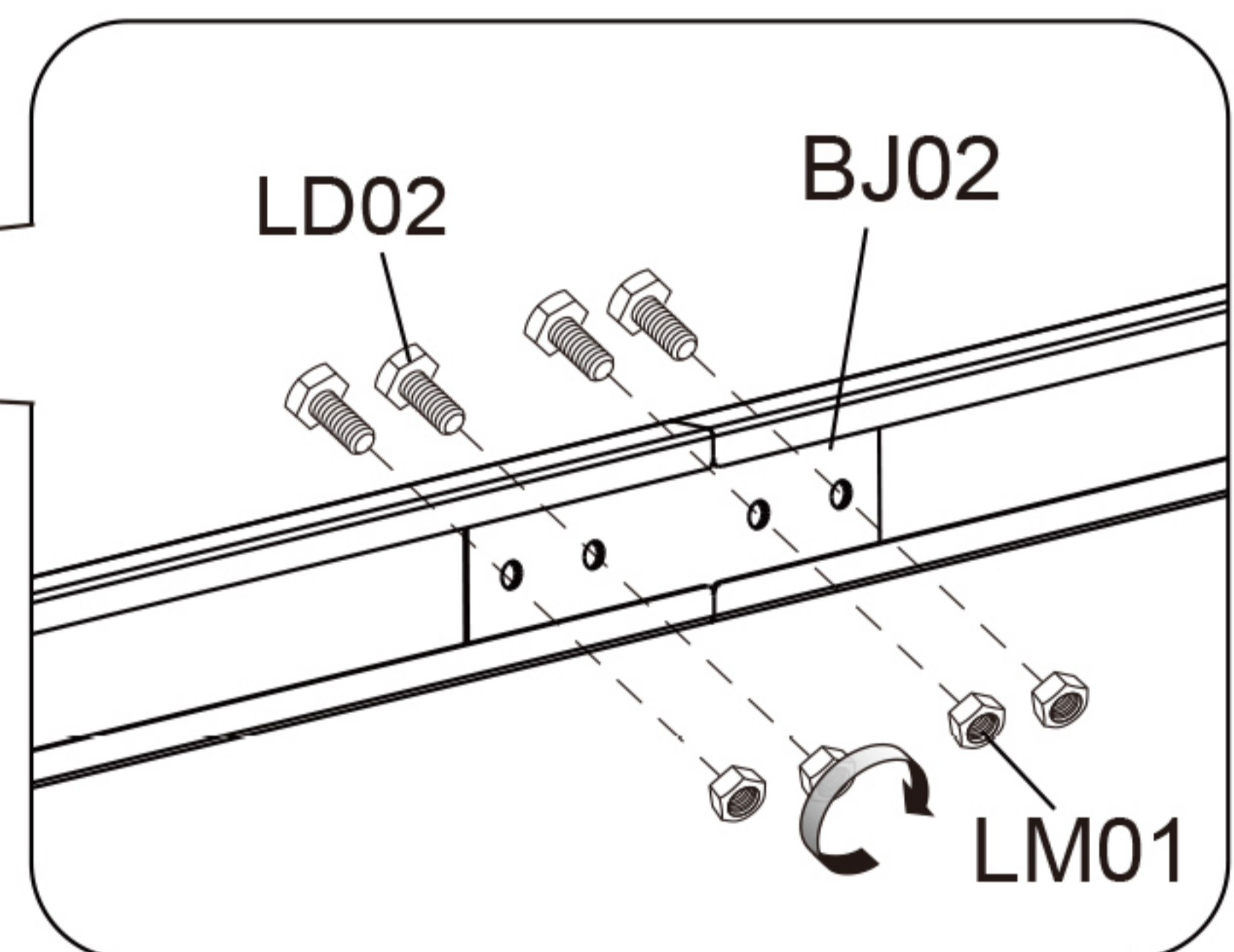
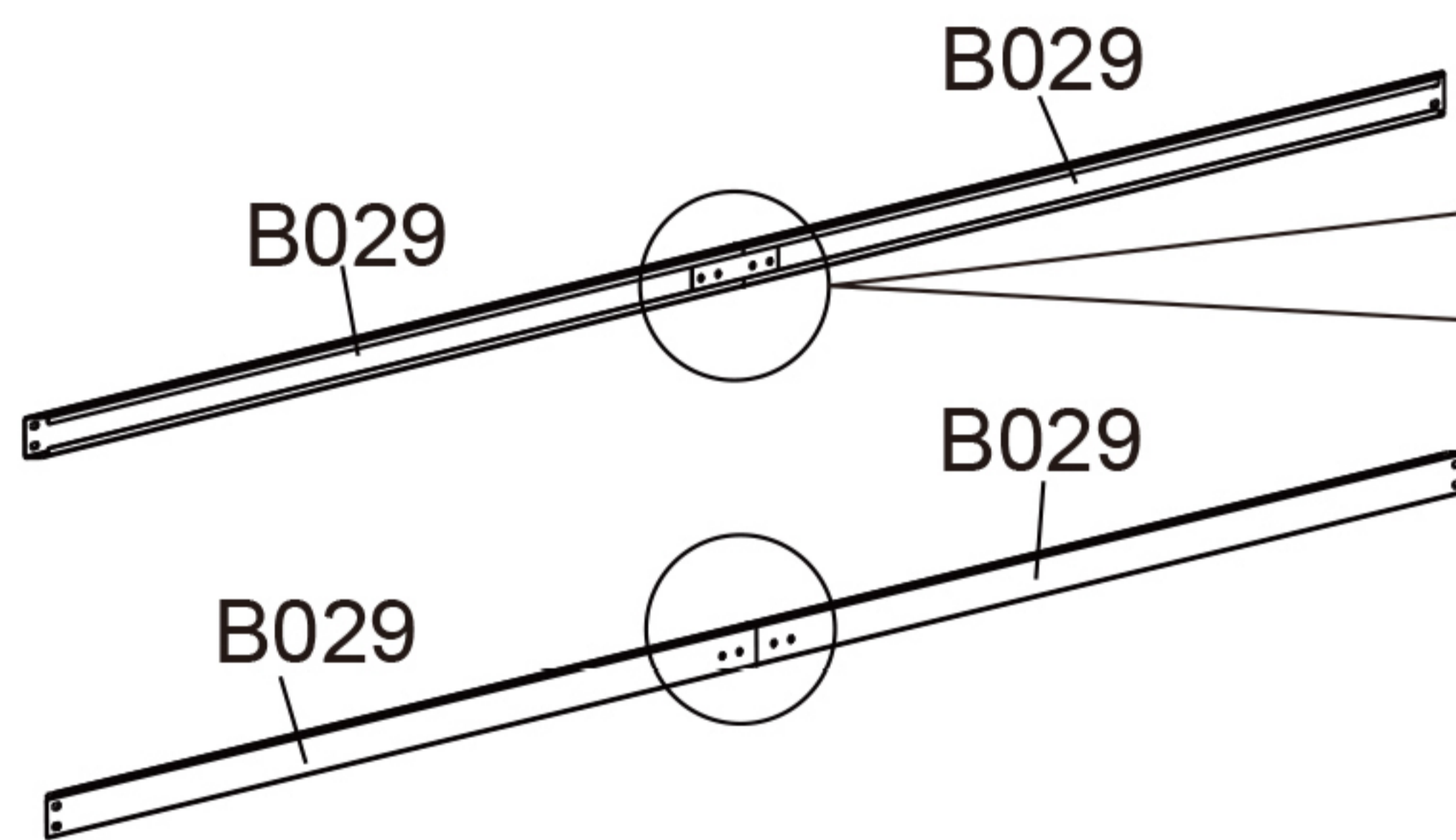

STEP 2

Use BJ01 to connect B01 and assembled Part in step 1 (B029)

The head of LD02 bolt face outside, and tight the nut LM01 inside.

B01*2

BJ01*4

LD02*16

LM01*16

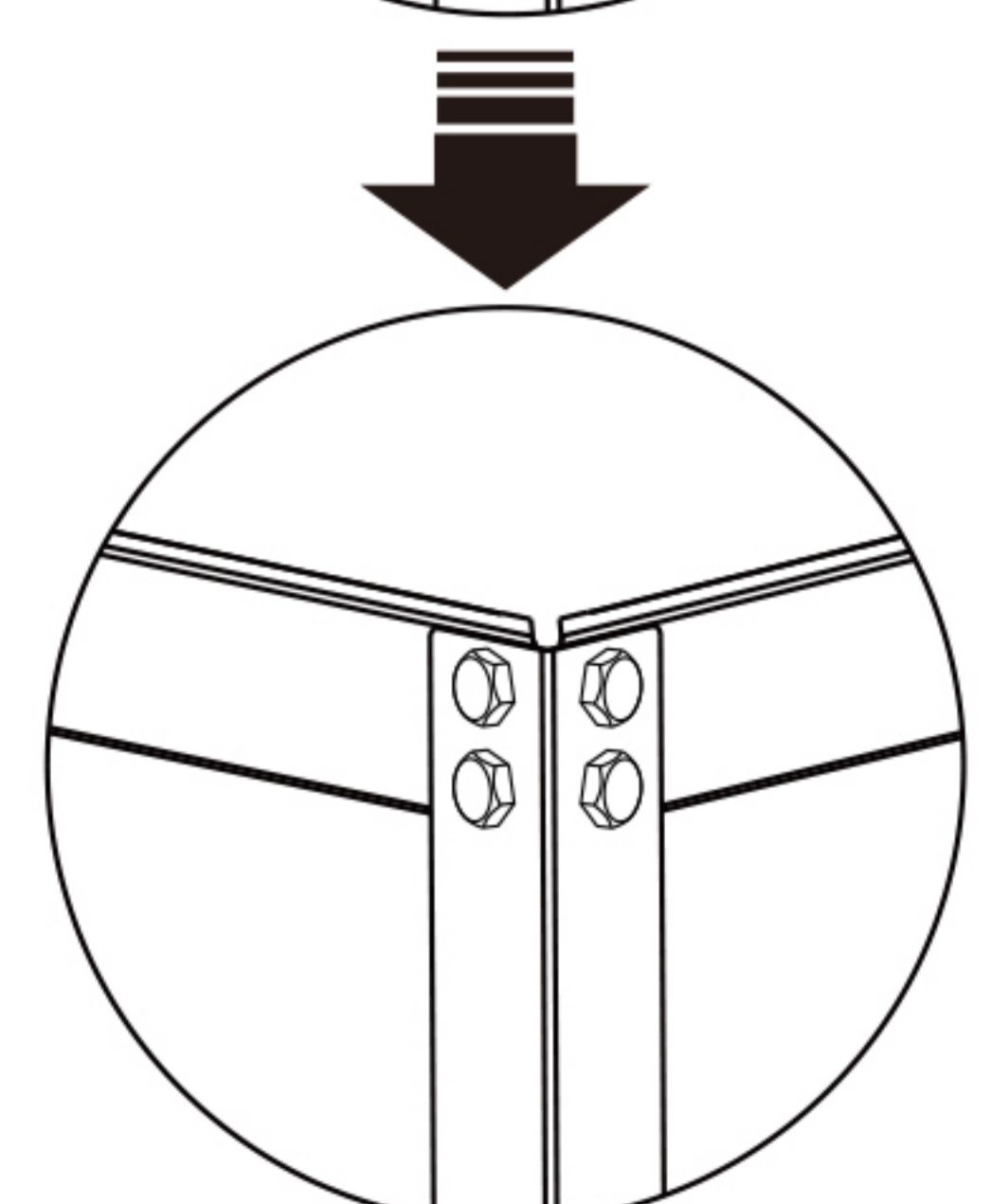
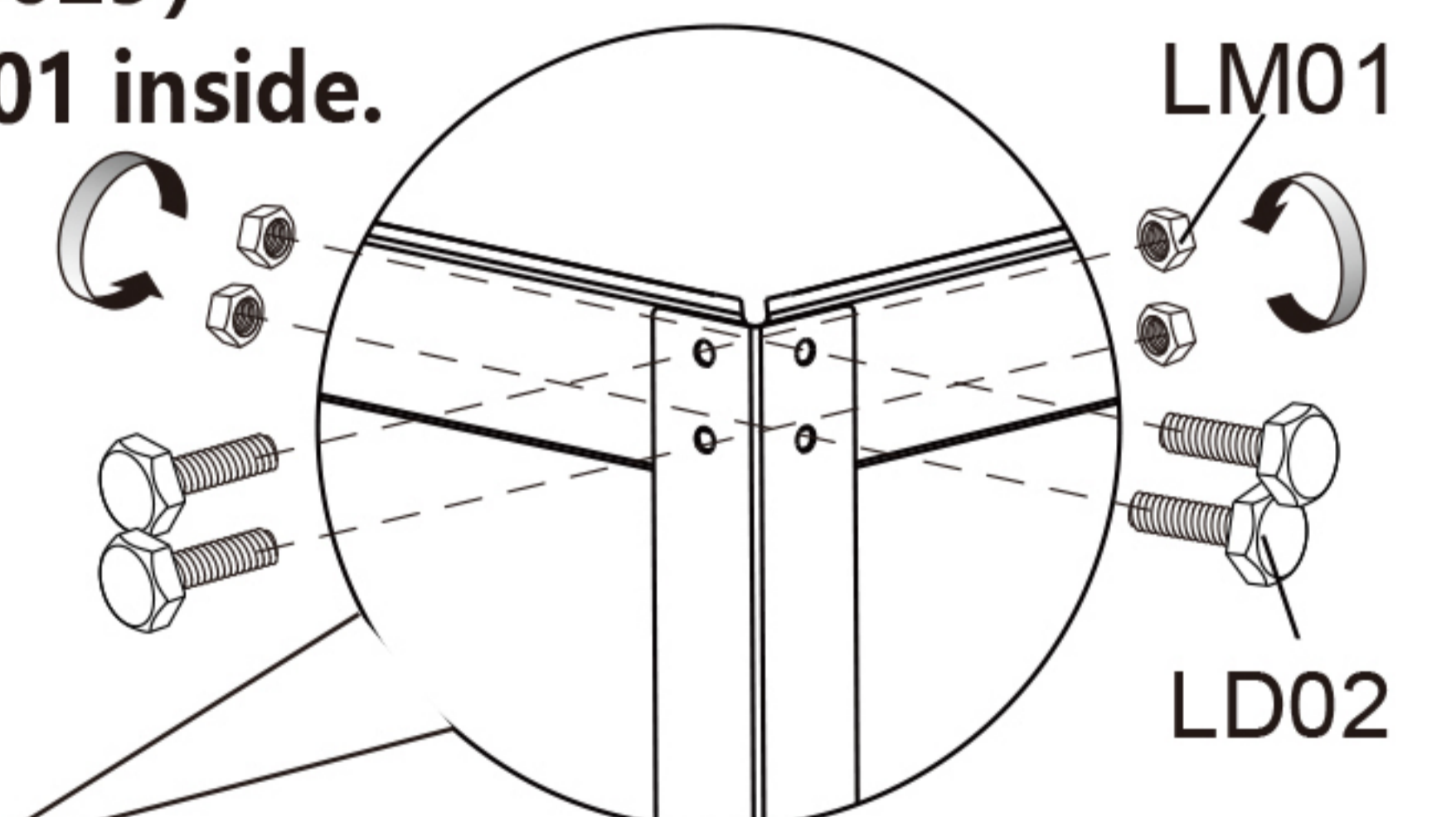
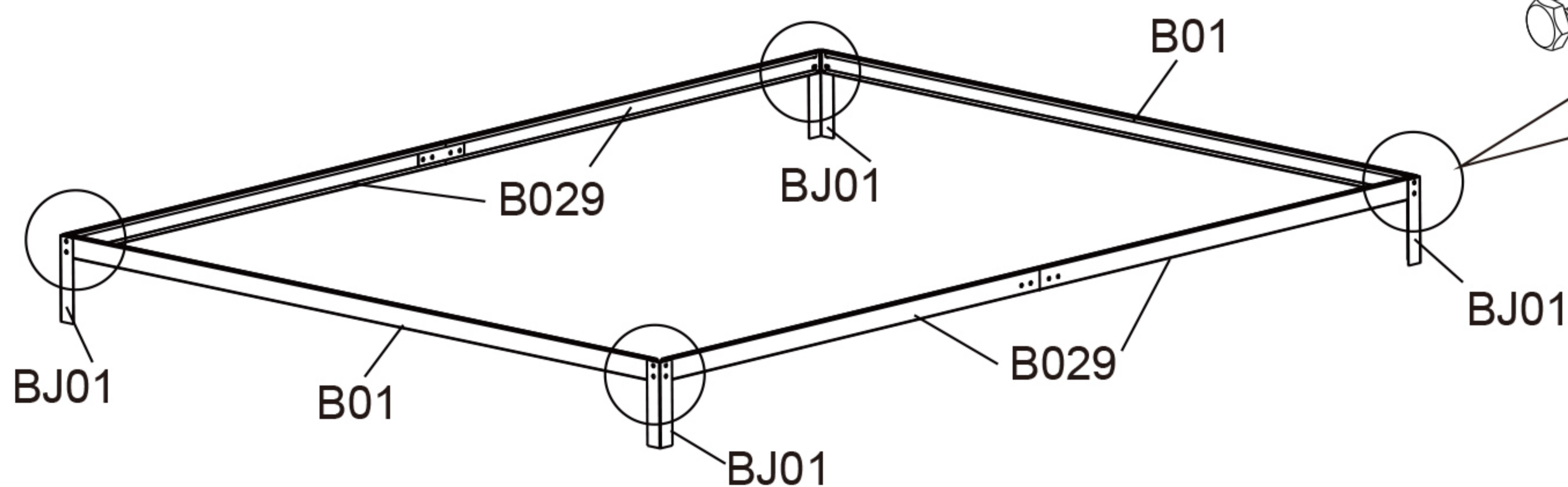

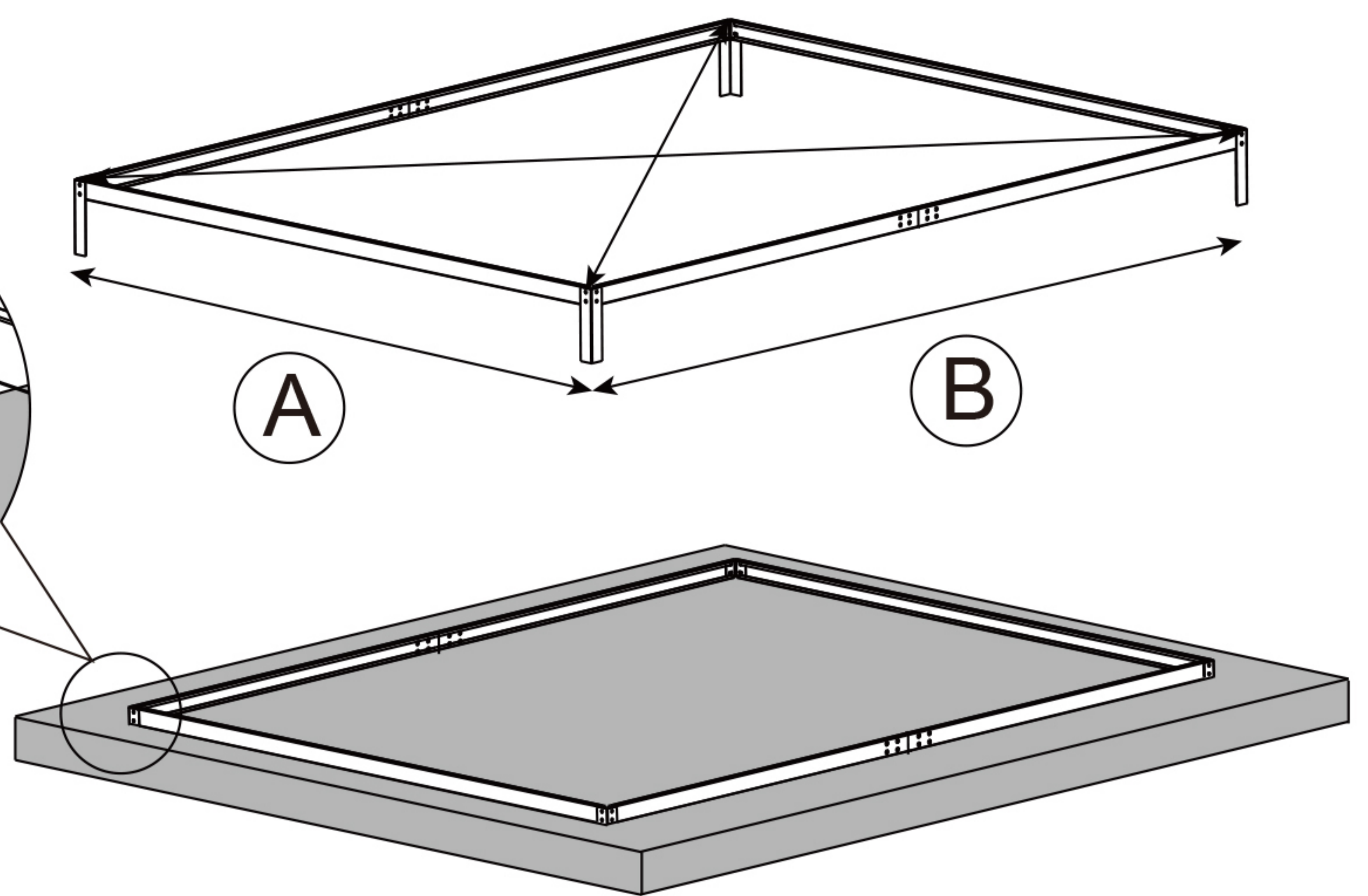
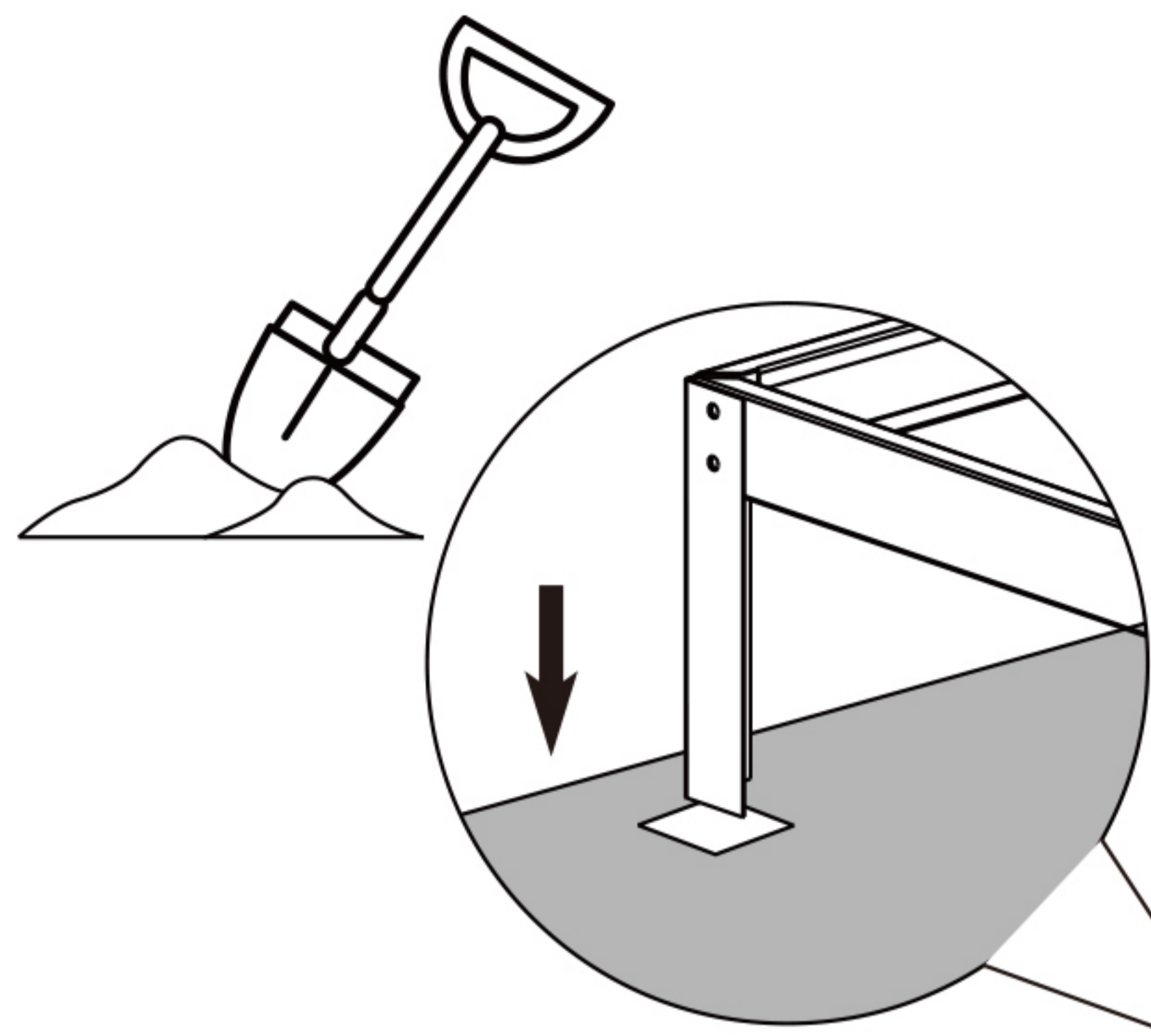
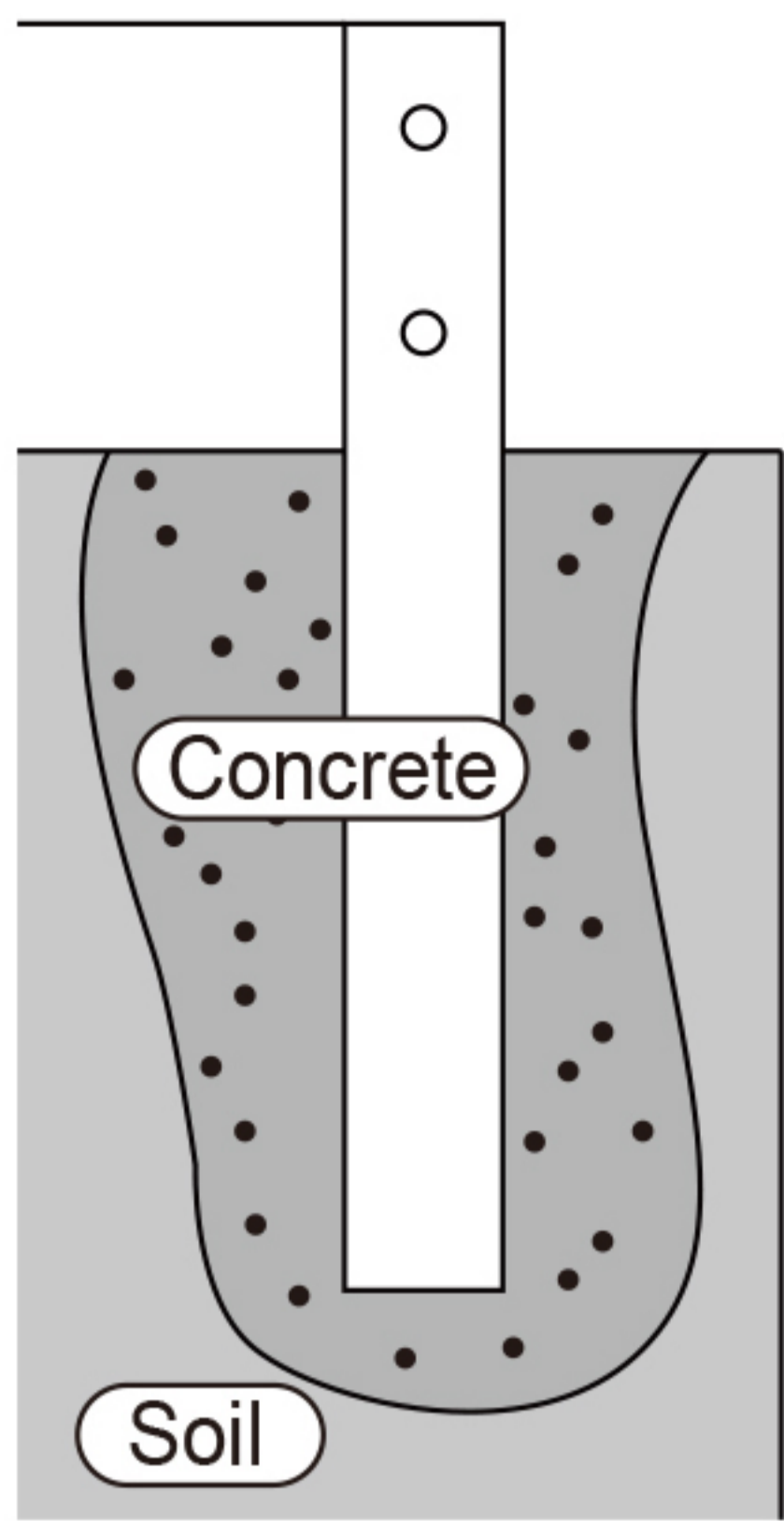

Corner Stakes mounted into concrete

Best option if you want your greenhouse fully secured.

Base Connector Assembly

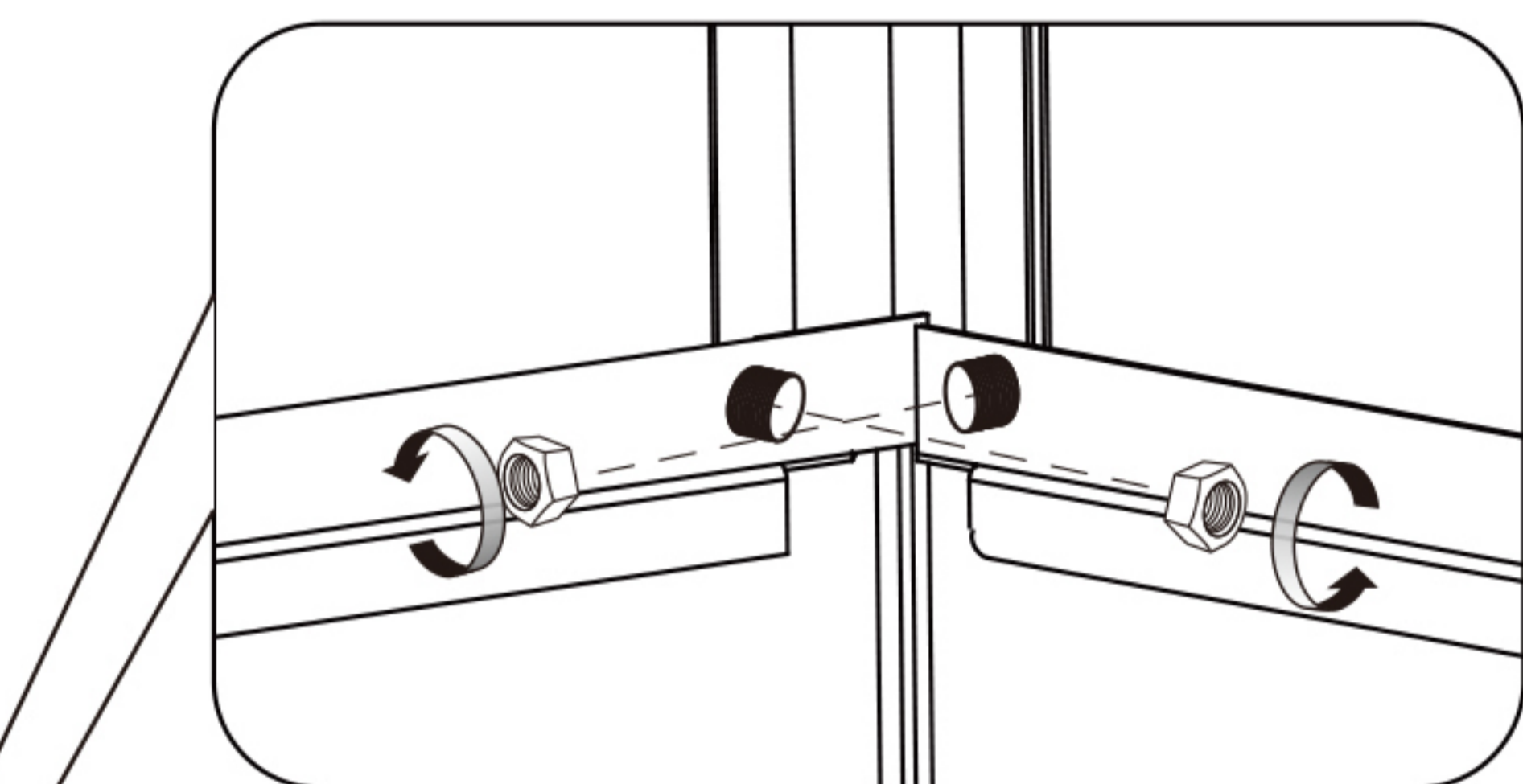
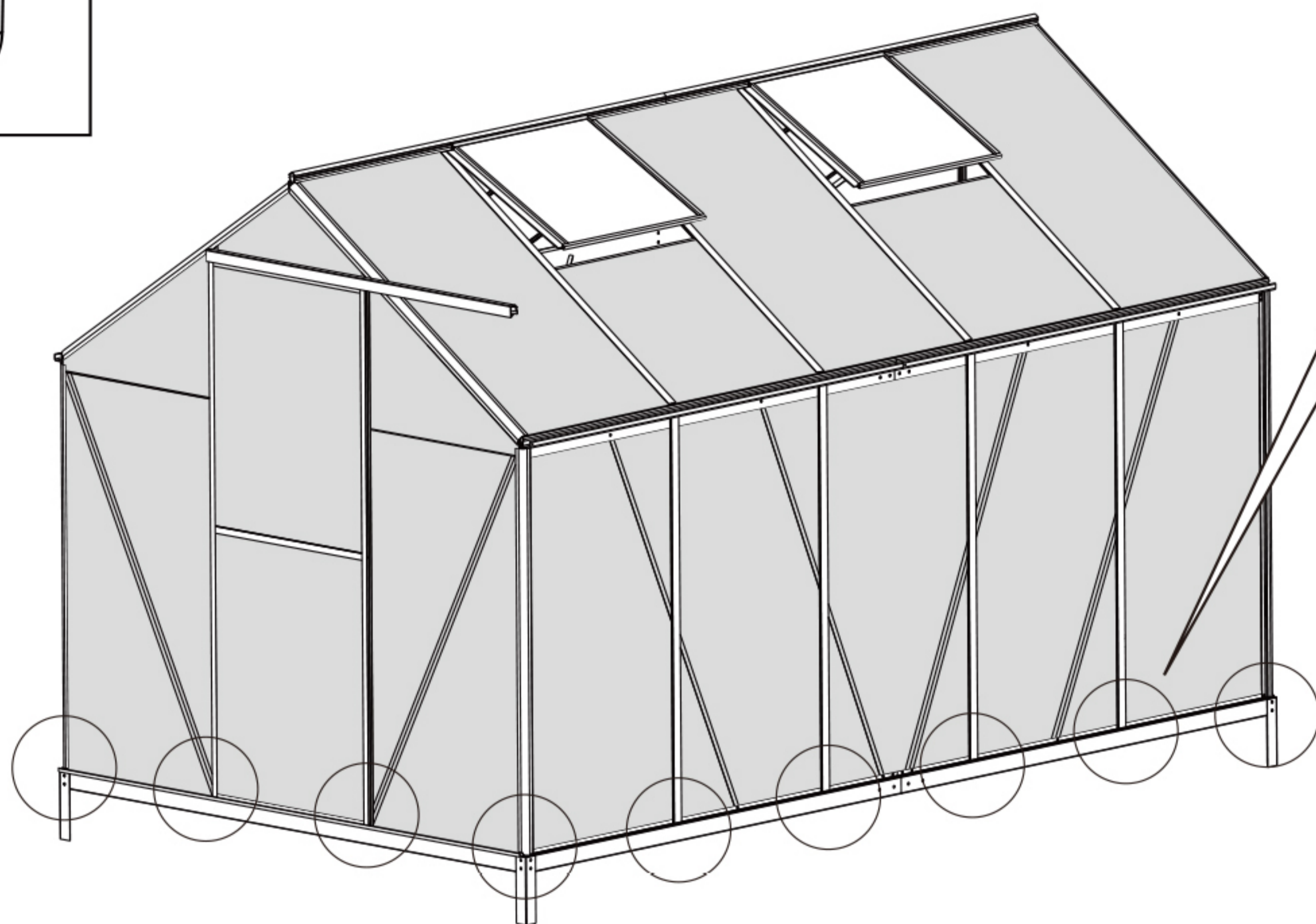
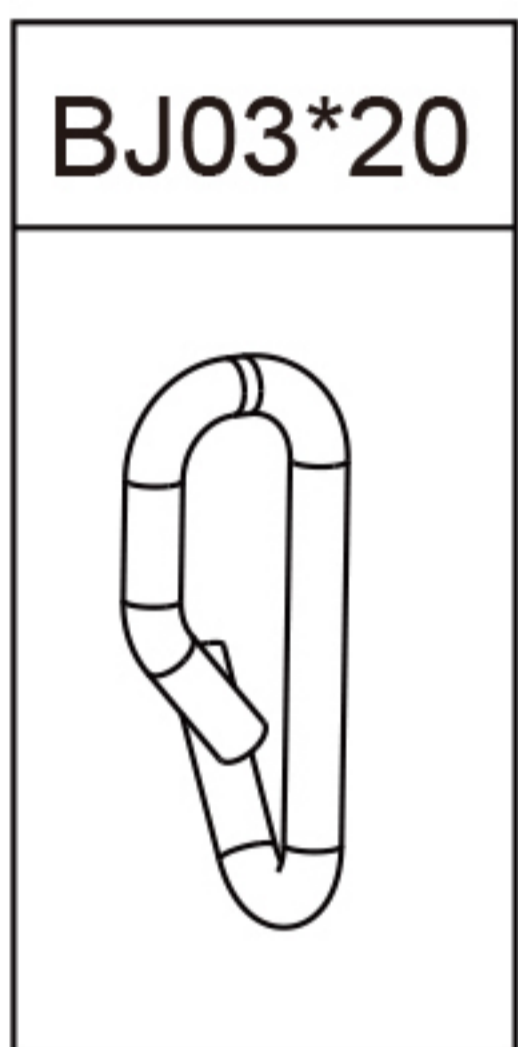

1. Loosen Nuts in position shown in the figure

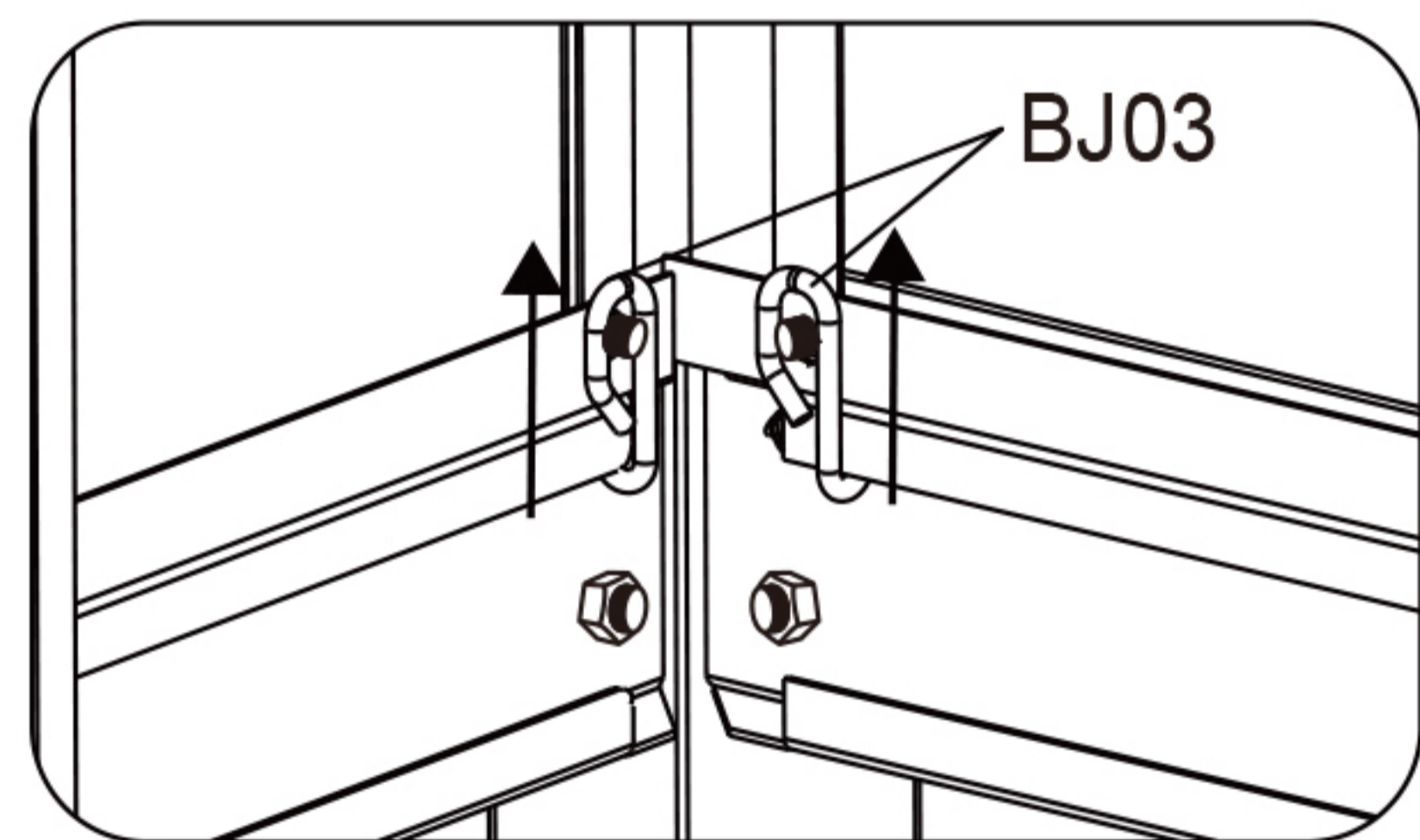

2. Hang the BJ03 connector on the base and lift it up to the bolts

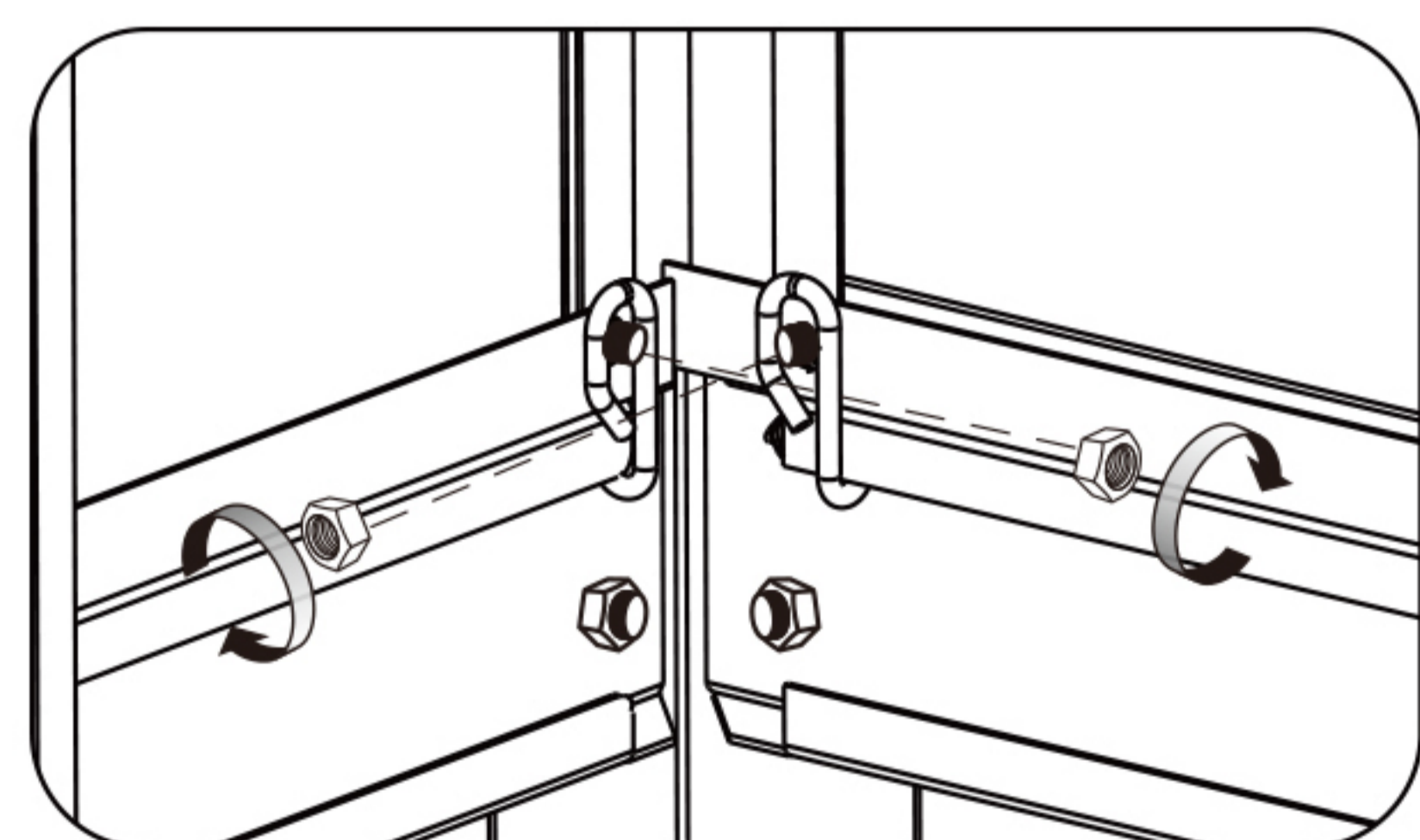

3. Fasten Nuts

Rear Gable side and Front Gable side both needs to install 4 BJ03 connectors.
 The side wall needs to install 7 BJ03 connectors.
 The installation position is as shown in the figure.
 The 8*6 size Green House needs 18 BJ03 connectors in total.