

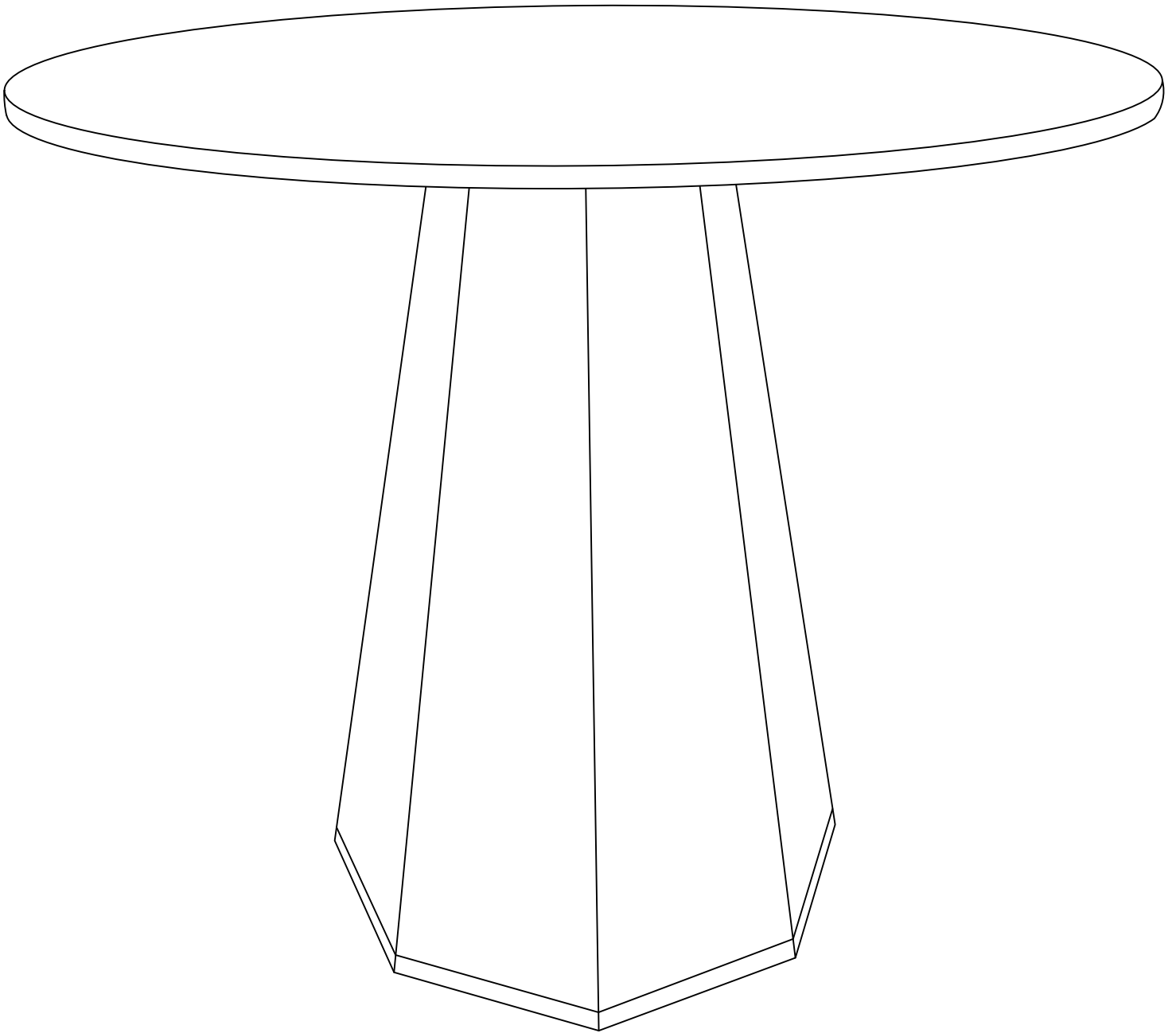

ASSEMBLY INSTRUCTION





TABLE

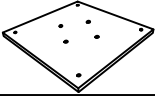
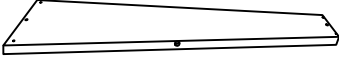
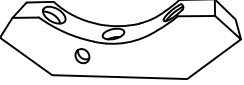
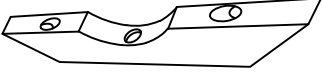

Component List

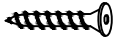
LABEL	PICTURE	DESCRIPTION	QTY
A		Table Top	1 PC
B		Table Support	1 PC
C		Leg Board	8 PCS
D		Up Support	4 PCS
E		Down Support	4 PCS

Hardware List

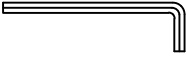
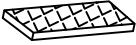
LABEL	PICTURE	DESCRIPTION	QTY
H1		JCBC W M6 x 30mm	24 PCS
H2		JCBC Screw M6 x 30mm	8 PCS
H3		Flat Washer M6 x 13mm	8 PCS
H4		Spring Washer M6	8 PCS
H5		Wood Dowel M6 x 30mm	8 PCS
H6		Allen Key M4	1 PC
H7		Paste Pad 22mm	8PCS

1

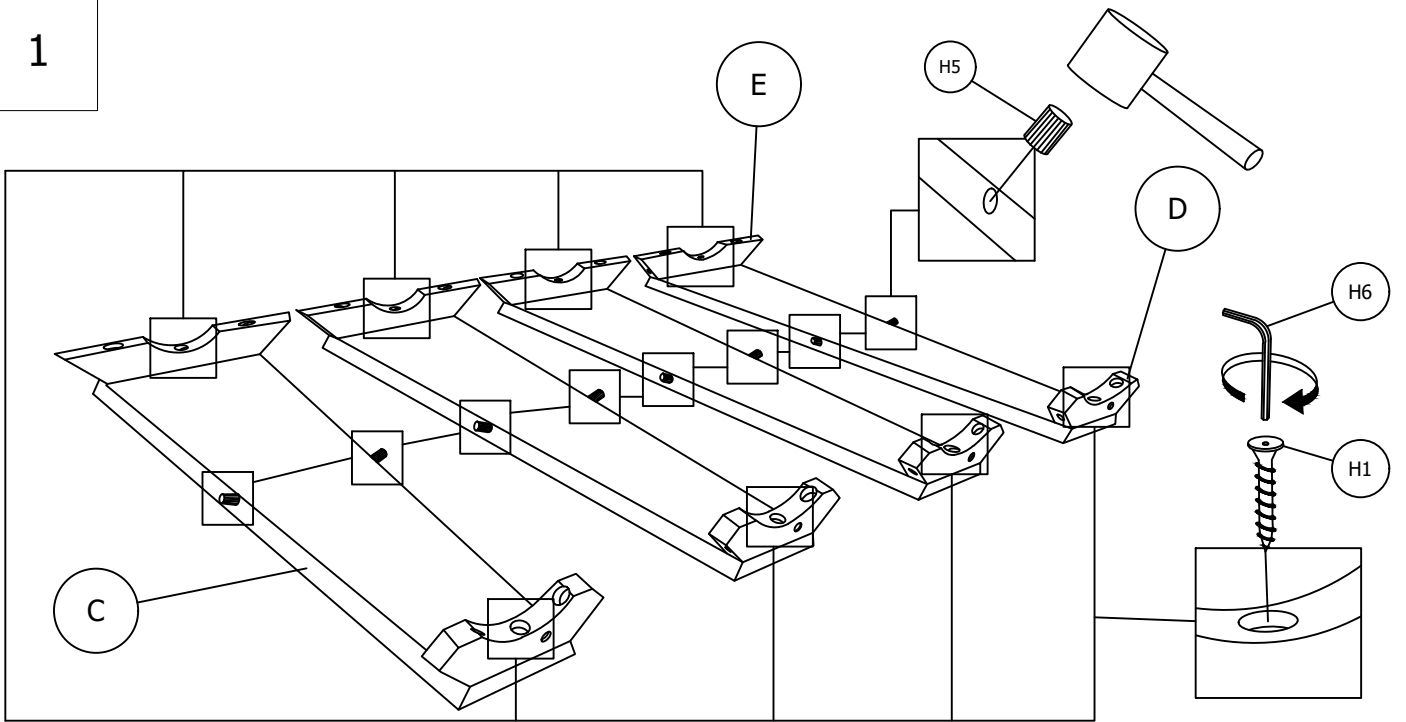

SCREW UPPER AND LOWER SUPPORTS TO FOUR LEG BOARDS, THEN INSERT WOOD DOWELS INTO SIDE HOLES.

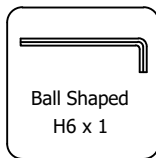
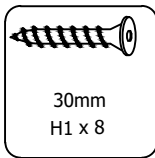

2

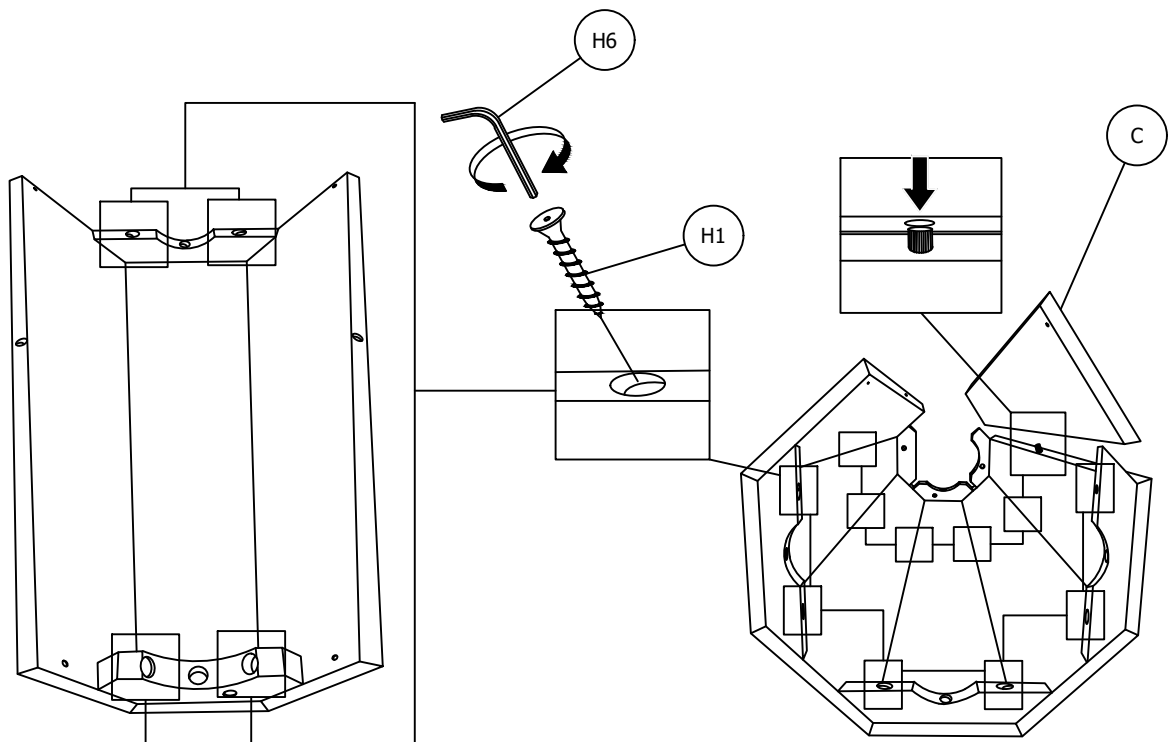

ATTACH 4 MORE LEG BOARDS TO INSERTED DOWELS, THEN SCREW THEM IN. FORMS AN OCTAGONAL SHAPE.

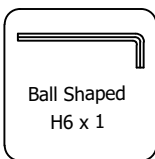
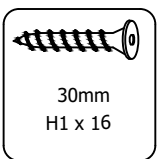

3

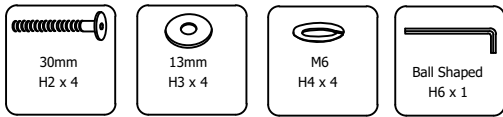
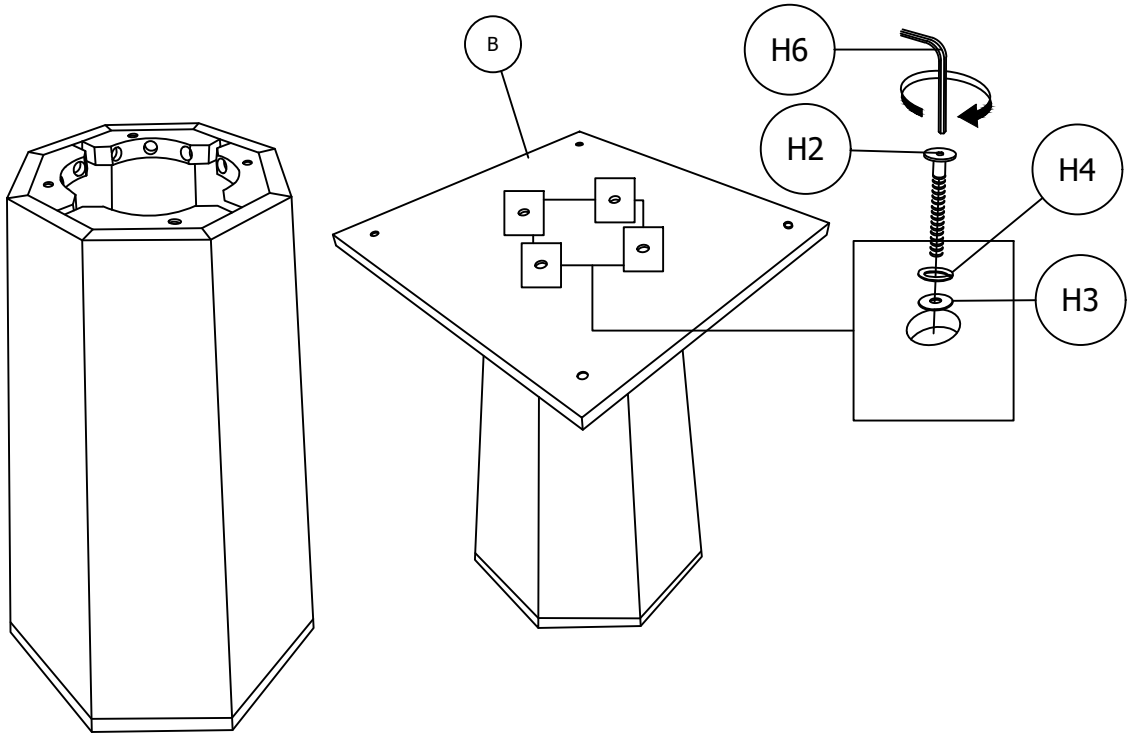

4

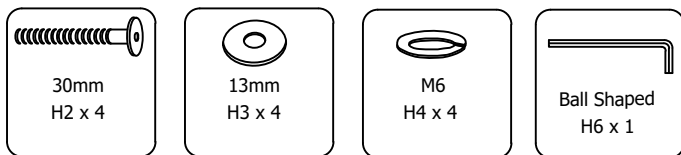
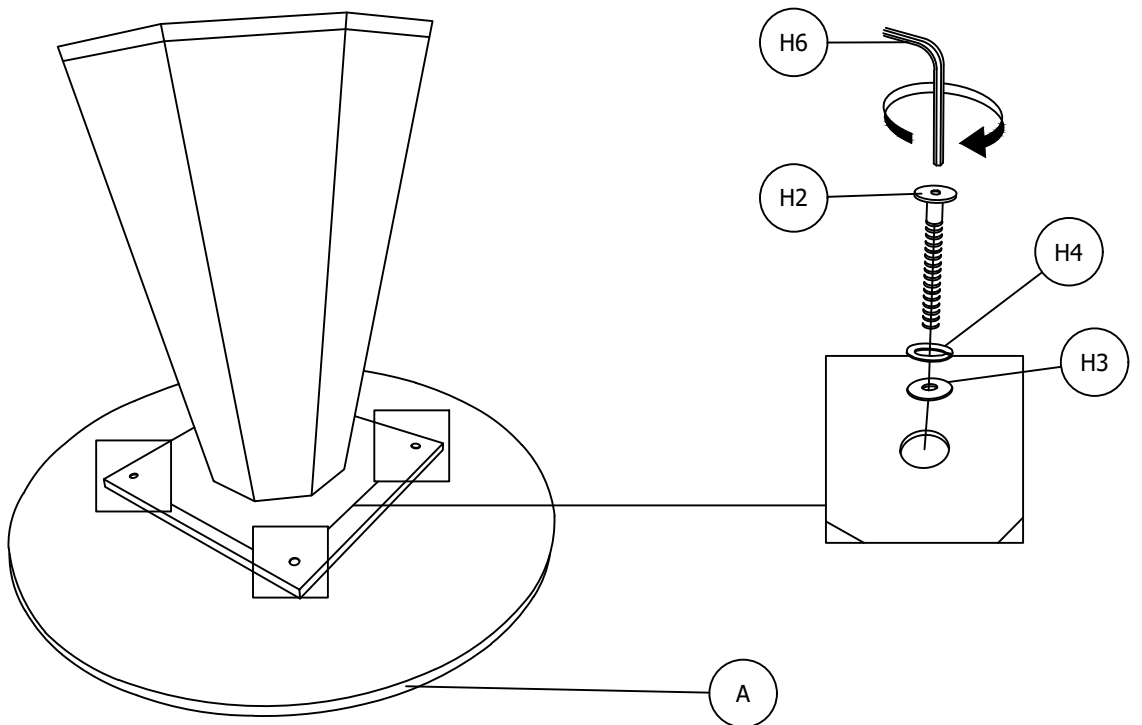

5

