

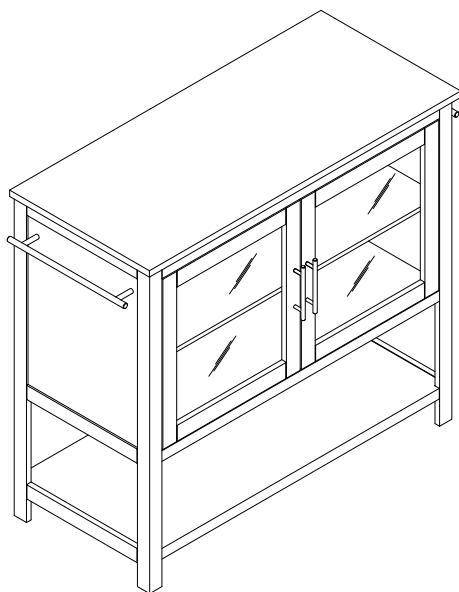

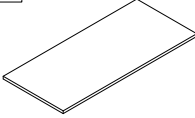

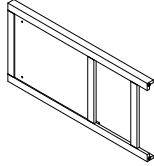

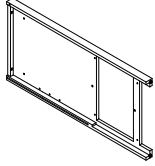

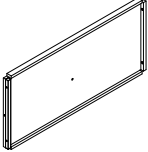
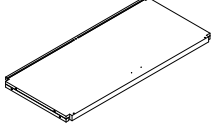
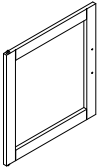

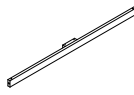
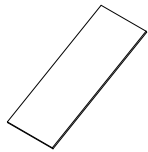
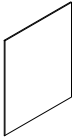
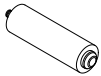
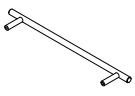
Kitchen Island

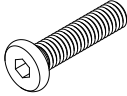

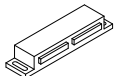
PART LIST

A 	B 	C 	D 	E 
Top Panel 1 PC	Left Panel 1 PC	Right Panel 1 PC	Bottom Panel 1 PC	Fixed Shelf 1 PC
F 	G 	H 	I 	J 
Door 2 PCS	Middle Back Panel 1 PC	Front Rail 1 PC	Adjustable Shelf 1 PC	Back Panel 2 PCS
K 	L 			
Support Leg 1 PC	Tower Bar 2 PCS			

HARDWARE LIST

<p>#1</p>  <p>Ø1/4"x1"</p>	<p>#2</p>  <p>Ø8x30mm</p>	<p>#3</p> 	<p>#4</p>  <p>Ø3x16mm</p>	<p>#5</p> 
<p>Bolt 18 PCS (Extra 1)</p>	<p>Wood Dowel 14 PCS (Extra 1)</p>	<p>Magnet 2 PCS</p>	<p>Screw 4 PCS (Extra 1)</p>	<p>Handle 2 PCS</p>
<p>#6</p>  <p>Ø5/32"x3/4"</p>	<p>#7</p> 	<p>#8</p> 		
<p>Round Head Bolt 8 PCS (Extra 1)</p>	<p>Shelf Holder 5 PCS (Extra 1)</p>	<p>Allen Wrench 1 PC</p>		

ADDITIONAL TOOLS (Not Provided)

Note: It is not recommended to use power tools during assembly.

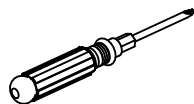

Phillips Head Screwdriver

Note: Wood dowels are intended for alignment. Additional clearance between wood dowel and pre-drilled hole is intentional for ease of assembly.

Step 1. Attach tower bars (part L) to panels (parts B & C) using round head bolts (part #6) and phillips head screwdriver. Attach handles (part #5) to doors (part F) using round head bolts (part #6) and phillips head screwdriver.

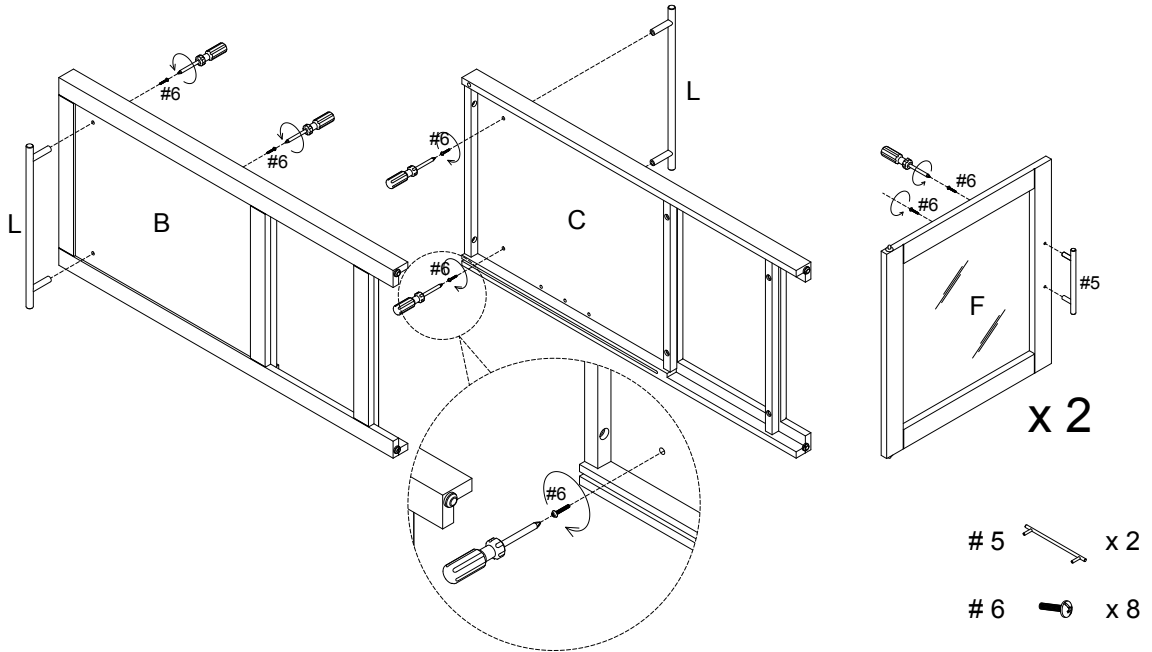

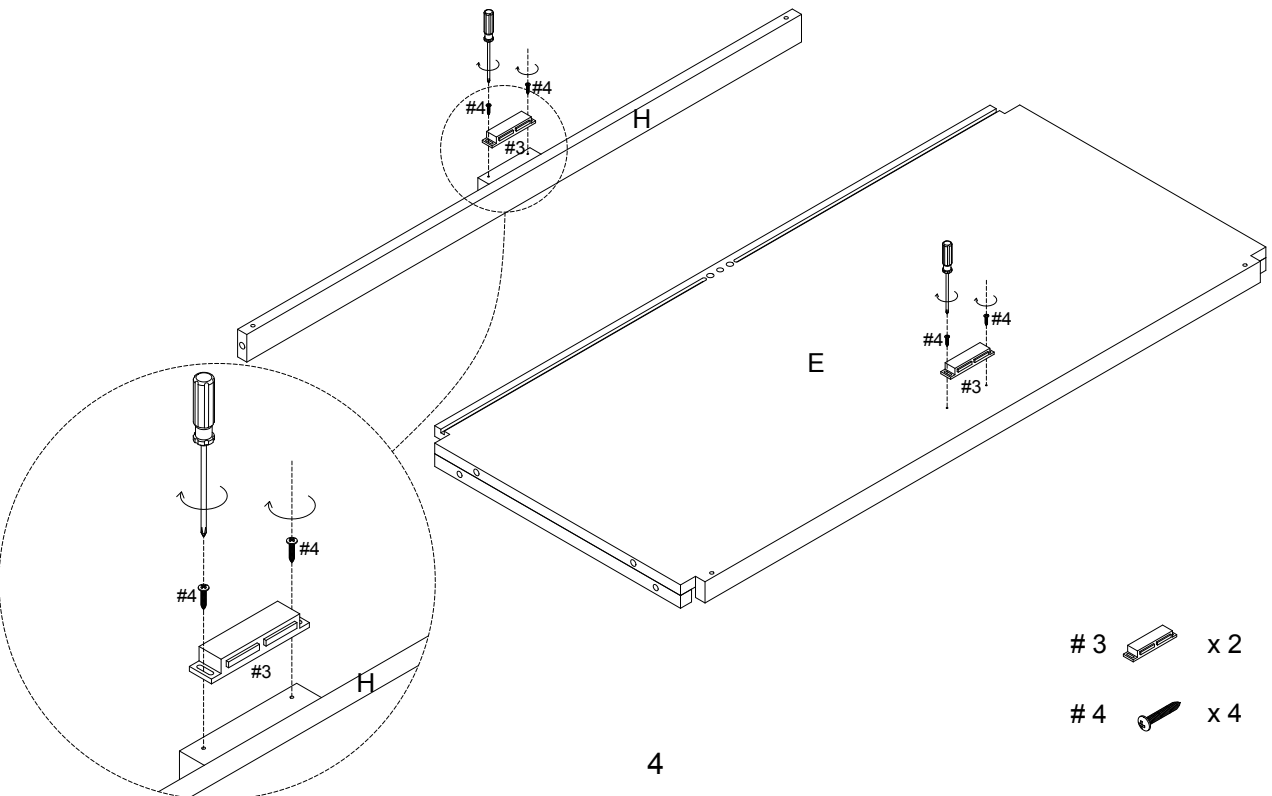

Step 2. Attach magnets (part #3) to front rail (part H) and fixed shelf (part E) using screws (part #4) and phillips head screwdriver.



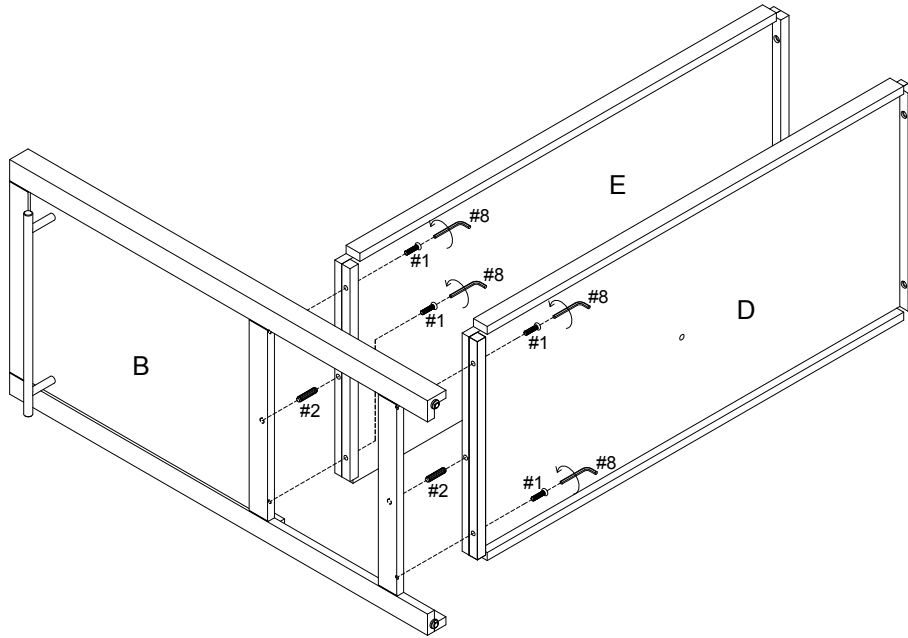



Step 3. Attach bottom panel (part D) and fixed shelf (part E) to left panel (parts B) using bolts (part #1), wood dowels (part #2) and allen wrench (part #8).

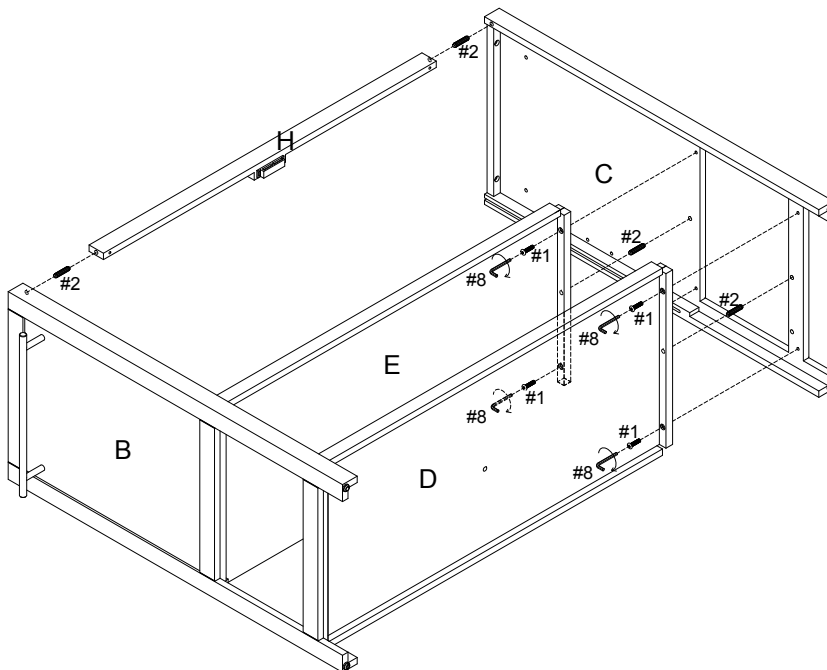

- # 1  x 4
- # 2  x 2
- # 8  x 1



Step 4. Attach right panel (part C) and front rail (part H) to assembled unit (parts D, E & H) using bolts (part #1), wood dowels (part #2) and allen wrench (part #8).

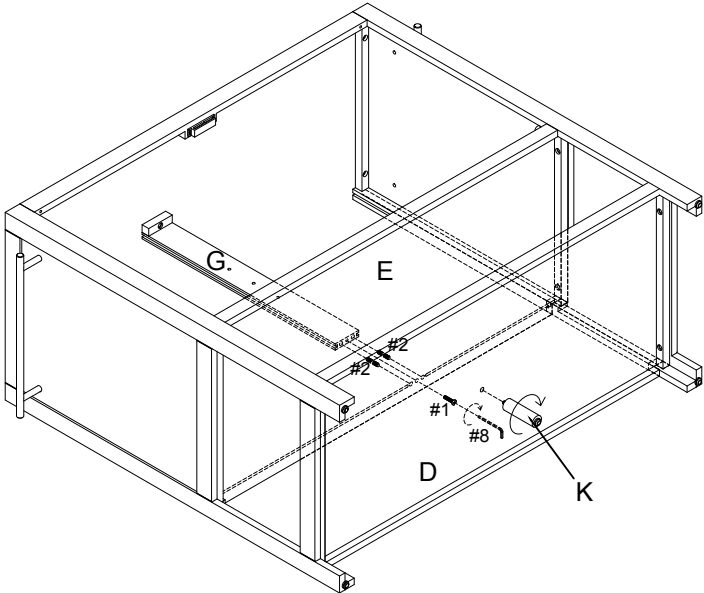

- # 1  x 4
- # 2  x 4
- # 8  x 1

Step 5. Attach middle back panel (part G) to fixed shelf (part E) using bolt (part #1), wood dowels (part #2) and allen wrench (part #8). Attach support leg (part K) to bottom panel (part D).



- # 1  x 1
- # 2  x 2
- # 8  x 1

Step 6. Carefully turn assembled unit upright. Slide back panels (part J) to assembled unit (parts B, C, E & G).

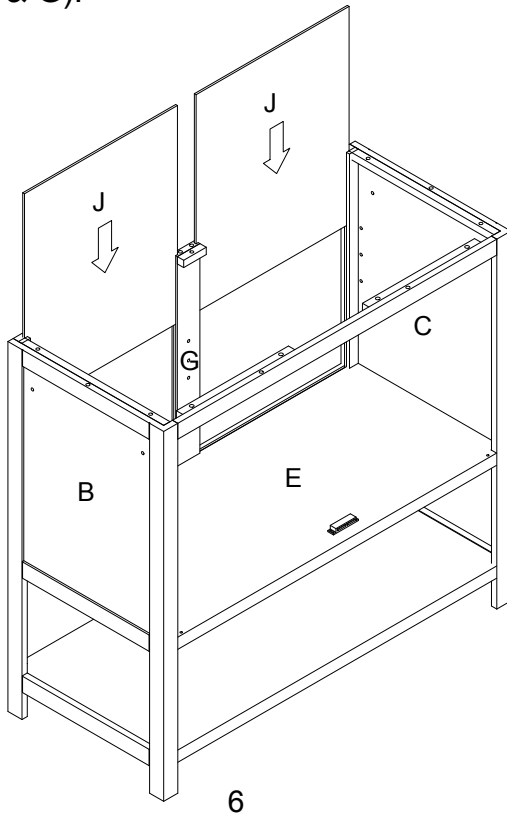

Step 7. Attach top panel (part A) to assembled unit (parts B, C, G, H & J) using bolts (part #1), wood dowels (part #2) and allen wrench (part #8).

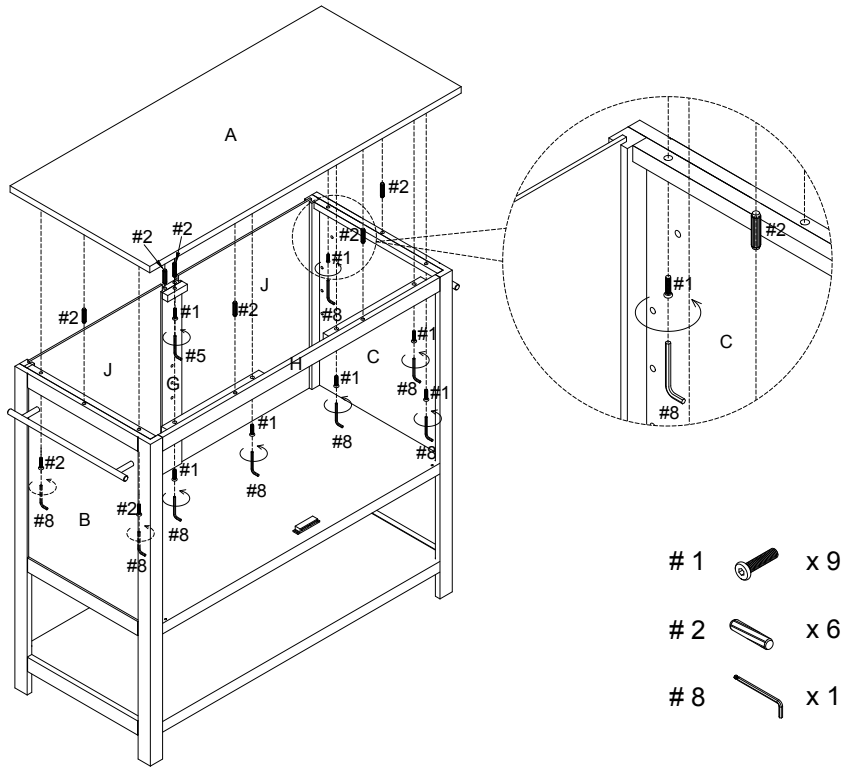

Step 8. Place shelf holders (part #7) into desired position and slide adjustable shelf (part I) into place.

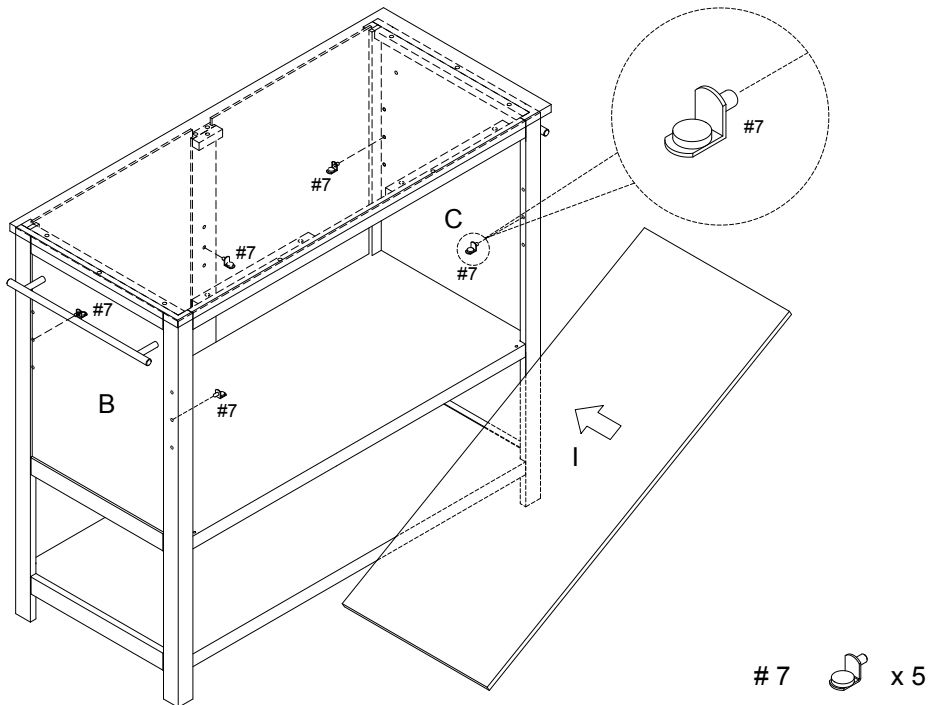

Step 9. Attach doors (part F) by placing bottom pin hinge (pre-installed in door) in the pre-drilled hole of fixed shelf (part E). Then depress the top spring-loaded pin hinge so it can be placed in the pre-drilled hole of front rail (part H).

Note: Be sure top and bottom pin hinges are fully extended to secure doors in place.

Note: It is important to adjust levelers once fully assembled and upright. Extend adjustable leveler until it's firmly in contact with the floor. If relocating, adjust leveler as needed until it's firmly in contact with the floor in new location.

