

# Assembly Guide

## Contents

English ————— 01-08

German ————— 09-16

French ————— 17-26

# Components

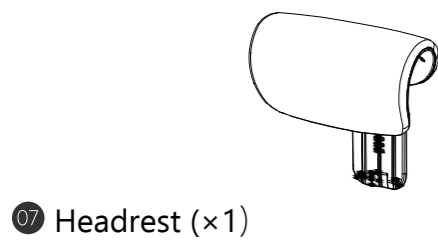
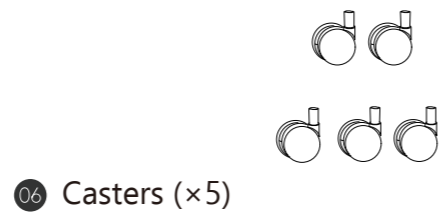
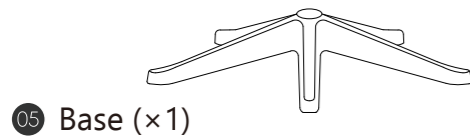
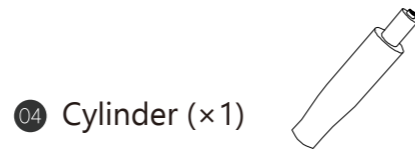
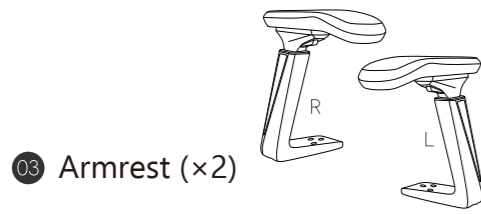
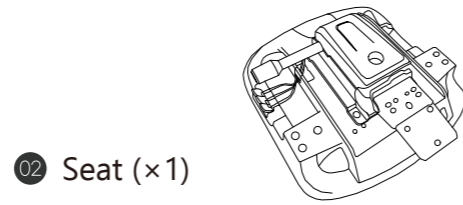
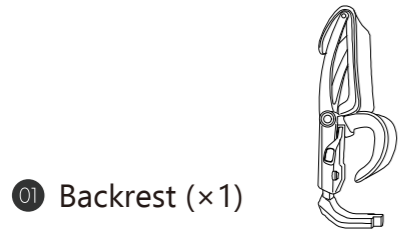

A x3+1 M8X40MM



B x6+1 M6X40MM



C x3+1 M8X17X1.5MM

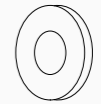

D x3+1 M8



E X6+1 M6X14X1.2MM

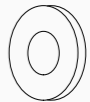

F X1

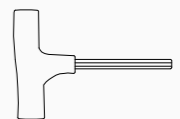

# Installation

The installation steps are as follows:

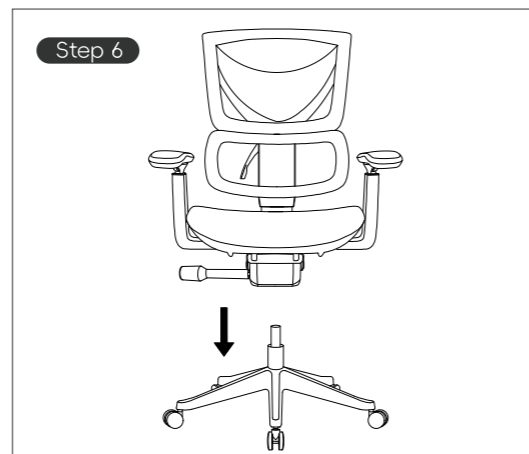
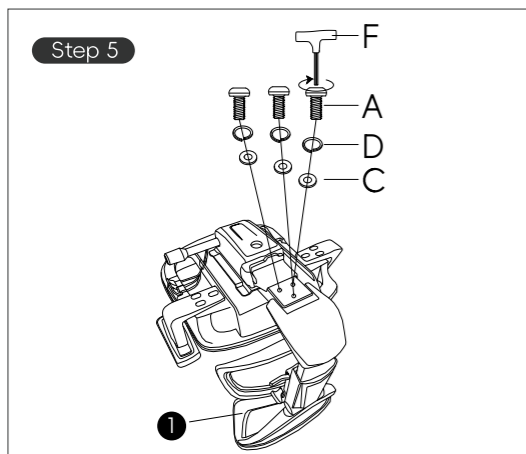
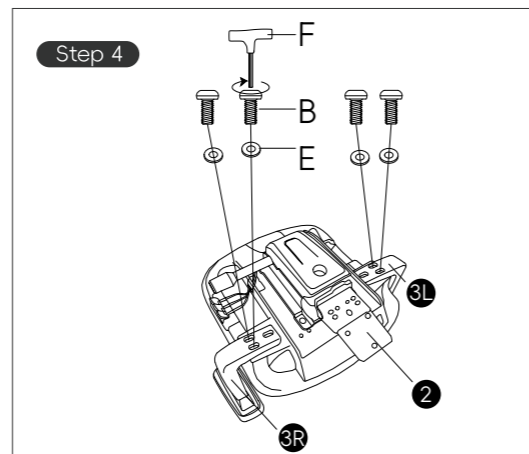
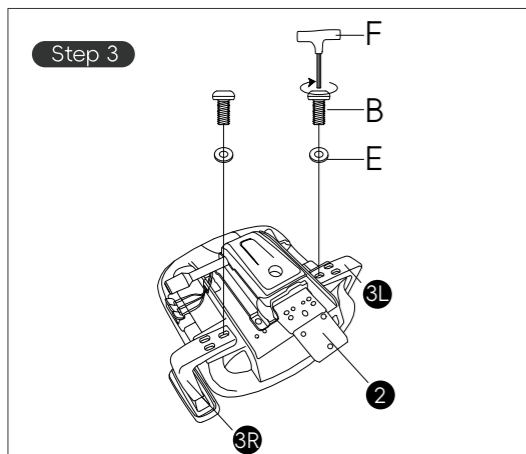
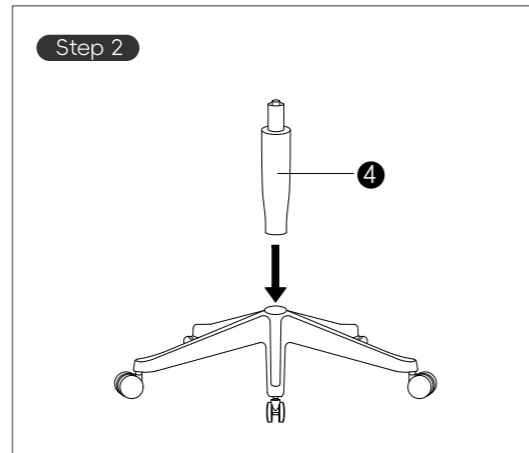
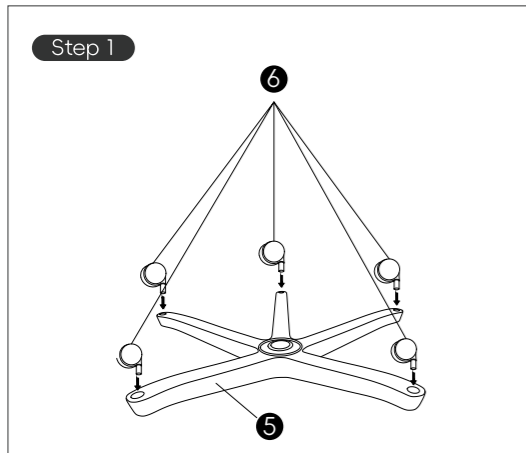

## All Done!

Go ahead, try it out. You may experience what we call an "ahhh" sensation.

That's completely normal. You're now well equipped for whatever the workday throws at you.

Now, don't be shy. Show us how us how it looks!

# User Guide

01

Adjustable headrest height and angle.

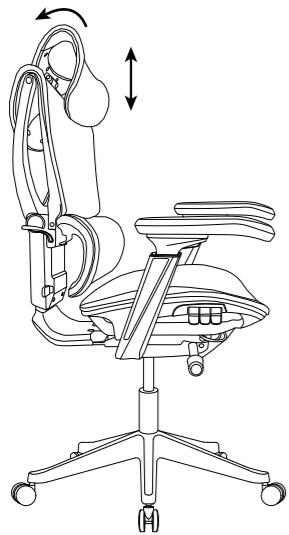

02

Adjustable armrest height, depth, and 20° rotation.

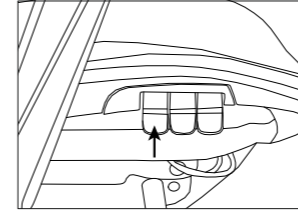
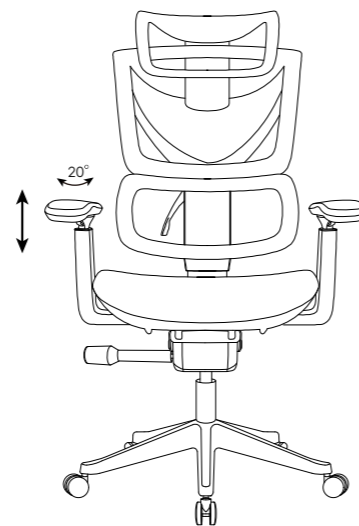

Lift the handle to lock the chair; press it down to release



Lift the handle to slide the seat cushion back and forth

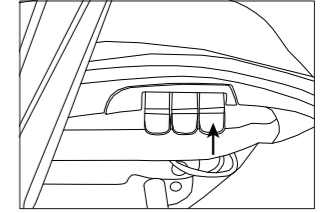

Lift the handle to adjust the seat height

03

Forward and backward armrest adjustment.

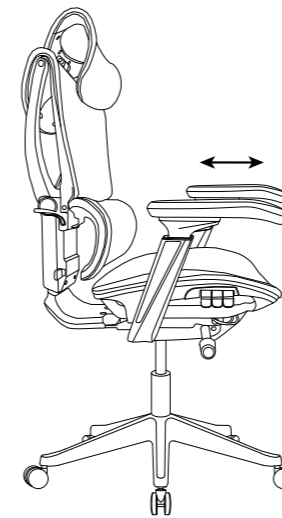

04

Turn the handle clockwise to increase recline tension, counterclockwise to decrease it.

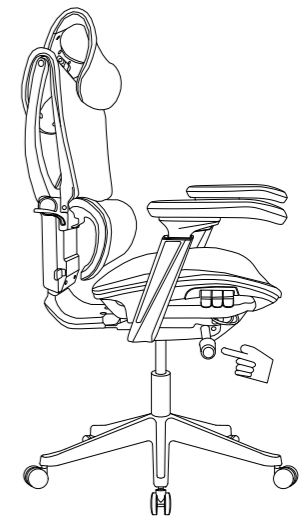

# User Guide

## 05

Press the small lever to adjust the backrest height

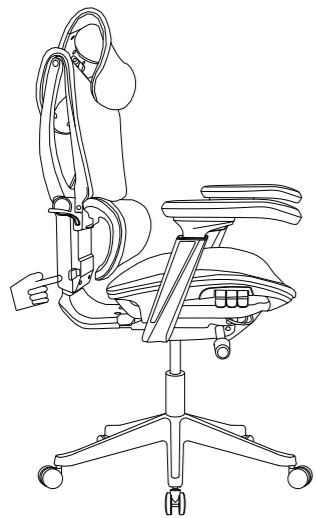

## 06

Position 1 locks the lumbar angle;  
Position 2 allows adjustment within the range

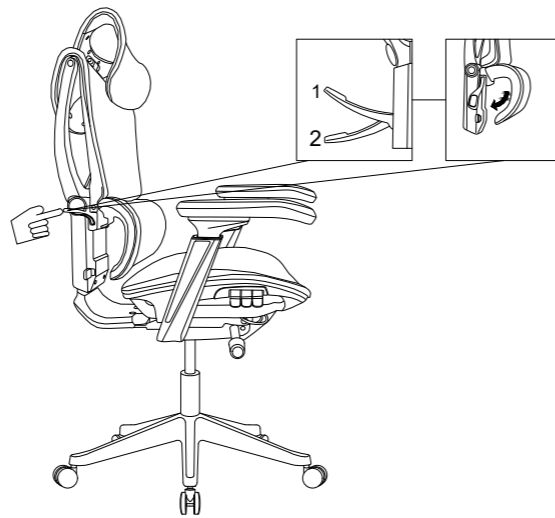

# Caution

- Use this product only for seating one person at a time.
- Some screws may be preassembled. If preassembled, ignore assembly instructions.
- Handle cylinders and mechanical components with care. They may contain grease that could stain chair surfaces or clothing if contacted.
- Do not use this chair as a step stool/ladder, or on uneven floor surfaces.
- Do not sit on any part of the chair except the seat.
- Do not use chair unless all bolts, screws, and knobs are tightened.
- Every six months, ensure all bolts, screws, and knobs are fully tightened to maintain stability.
- If any components are missing, damaged, deformed, or worn, discontinue use and repair only with manufacturer-authorized parts.
- Failure to follow these warnings could result in serious injury.

# Komponenten

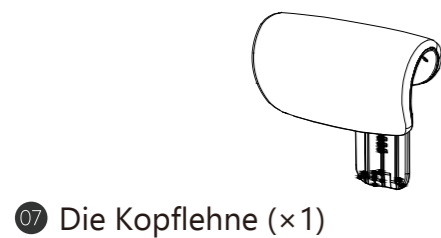
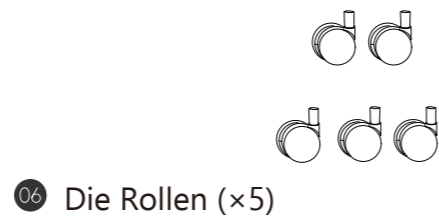
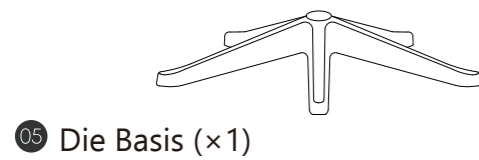
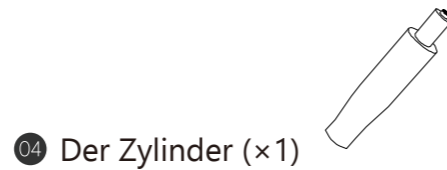
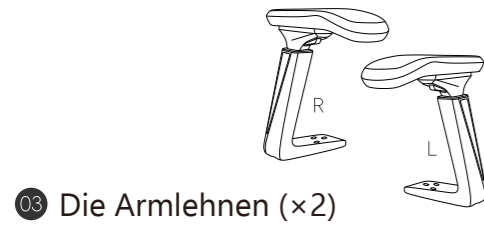
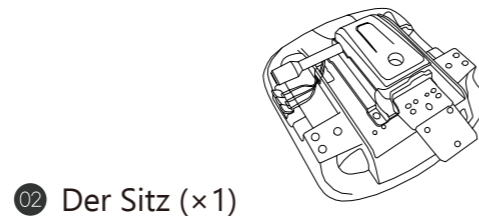
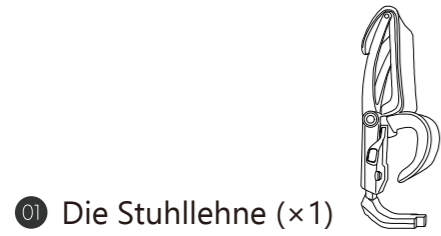

A x3+1 M8X40MM

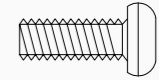

B x6+1 M6X40MM



C x3+1 M8X17X1.5MM



D x3+1 M8



E X6+1 M6X14X1.2MM



F X1

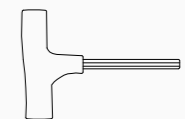

# Montageanleitung

Die Montageanleitung läuft wie folgt ab:

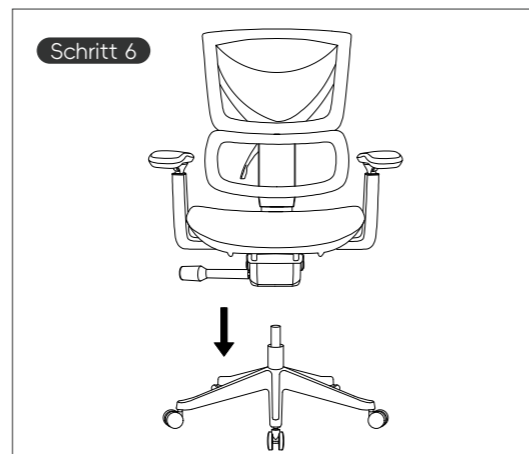
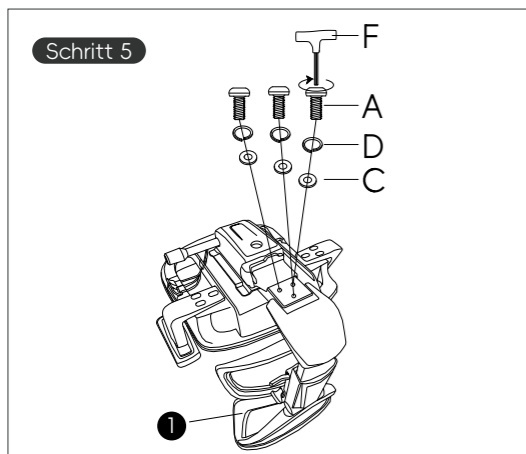
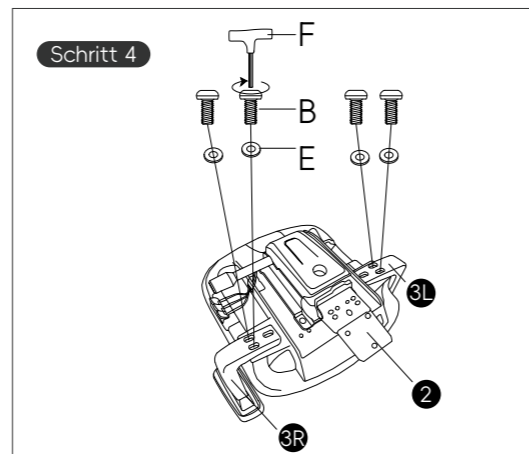
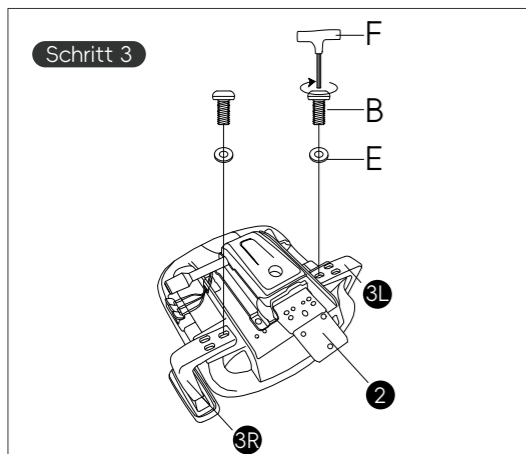
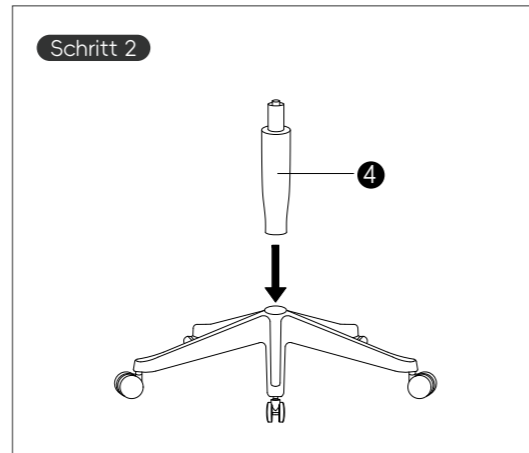
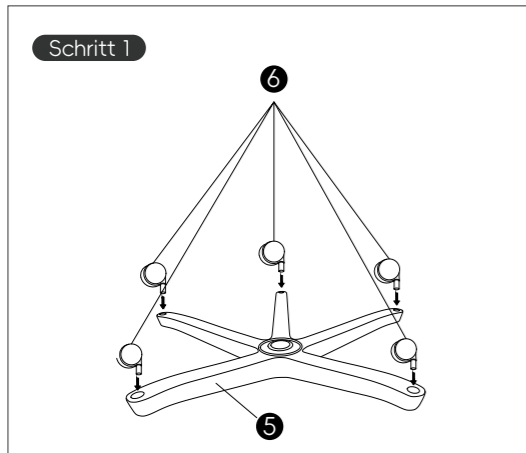

## Geschafft!

Probieren Sie es aus, Sie werden vielleicht ein „ahhh“ - Gefühl verspüren.

Das ist völlig normal. Sie sind jetzt gut gerüstet für alles, was der Arbeitstag Ihnen abverlangt.

Seien Sie nicht schüchtern, lassen Sie uns sehen, wie es aussieht!

# Benutzerhandbuch

## 01

Verstellbare Höhe und Neigung der Kopfstütze.

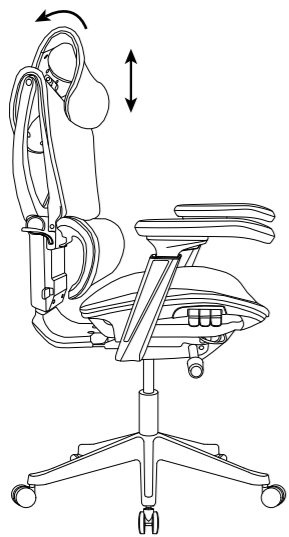

## 02

Verstellbare Armlehnenhöhe und 20°-Drehung.

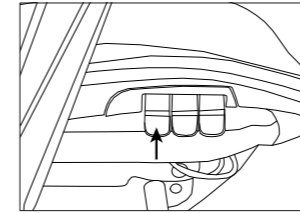
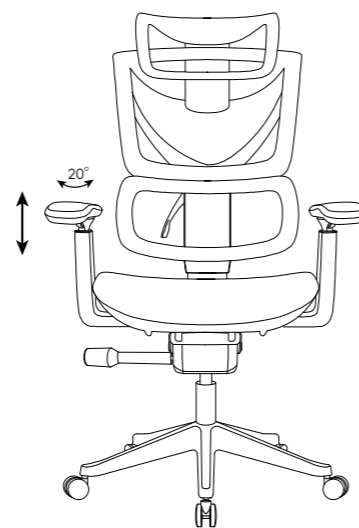

Taste nach oben drücken, um die Sitzhöhe einzustellen.

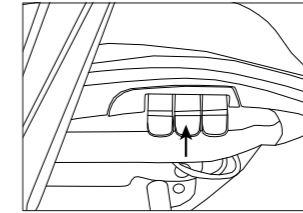

Taste nach oben drücken, um das Sitzkissen vor- und zurückzuschieben.

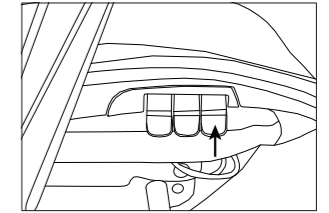

Taste nach oben drücken zum Arretieren, nach unten zum Lösen.

## 03

Verstellung der Armlehnen nach vorne und hinten.

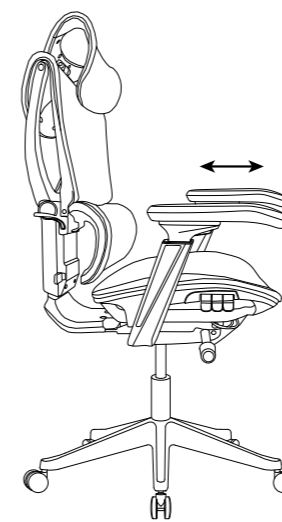

## 04

Griff im Uhrzeigersinn drehen, um die Spannung zu erhöhen, gegen den Uhrzeigersinn zum Verringern.

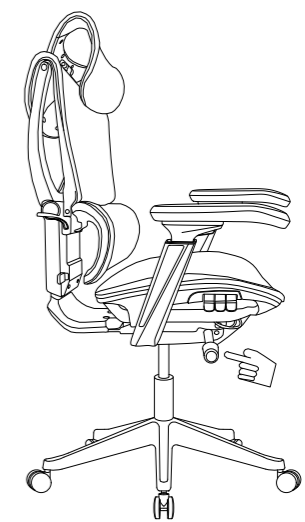

# Benutzerhandbuch

## 05

Drücken Sie den kleinen Hebel, um die Rückenlehnenhöhe einzustellen.

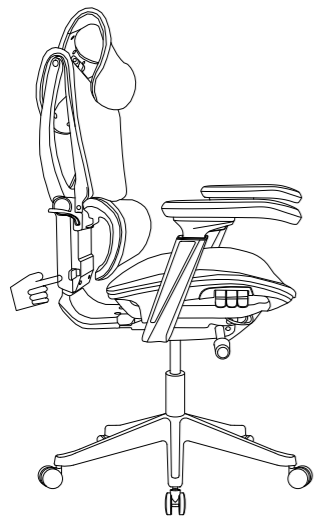

## 06

Position 1 arretiert den Lendenwinkel, Position 2 ermöglicht eine Verstellung im Bereich.

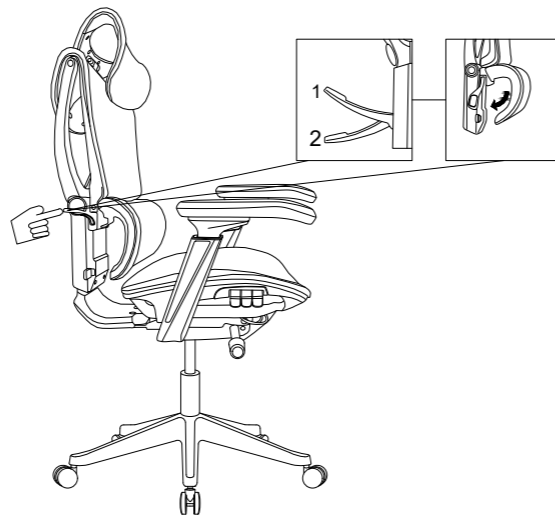

# Achtung

- Verwenden Sie dieses Produkt nur für die Benutzung durch jeweils eine Person.
- Einige Schrauben können vormontiert sein. Wenn sie vormontiert sind, ignorieren Sie die Montageanleitung.
- Sie können Schmierfett enthalten, die bei Kontakt mit der Stuhloberfläche oder der Kleidung Flecken verursachen kann.
- Verwenden Sie den Stuhl nicht als Tritthocker/Leiter oder auf unebenen Böden.
- Setzen Sie sich auf keinen Teil des Stuhls außer auf den Sitz.
- Benutzen Sie den Stuhl nicht, wenn nicht alle Bolzen, Schrauben und Knöpfe fest angezogen sind.
- Stellen Sie alle sechs Monate sicher, dass alle Bolzen, Schrauben und Knöpfe fest angezogen sind, um die Stabilität zu gewährleisten.
- Wenn Teile fehlen, beschädigt, verformt oder abgenutzt sind, verwenden Sie den Stuhl nicht mehr und reparieren Sie ihn nur mit vom Hersteller zugelassenen Teilen.
- Die Nichtbeachtung dieser Warnhinweise kann zu schweren Verletzungen führen.

# Composants

01 Dossier (x1)

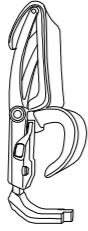

02 Siège (x1)

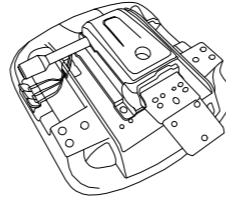

03 Accoudoirs (x2)

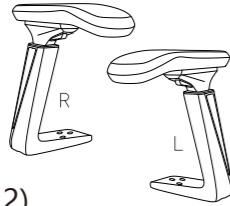

04 Cylindre (x1)

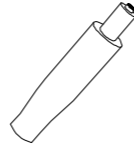

05 Base (x1)

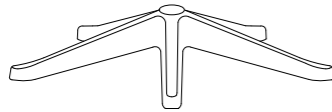

06 Roulettes (x5)



07 Appuie-tête (x1)

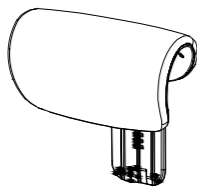

A x3+1 M8X40MM

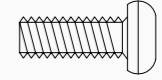

B x6+1 M6X40MM



C x3+1 M8X17X1.5MM

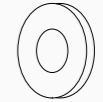

D x3+1 M8



E X6+1 M6X14X1.2MM



F X1

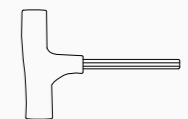

# Installation

Les étapes d'installation sont les suivantes :

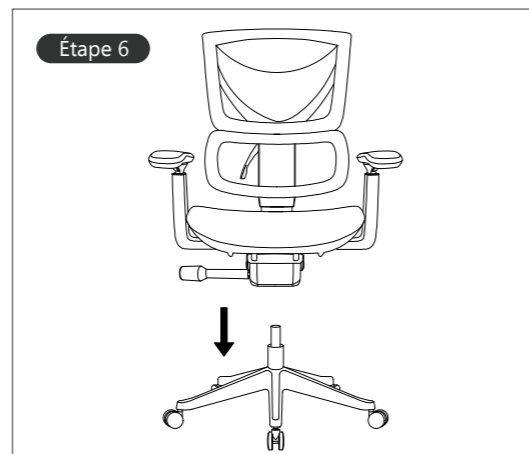
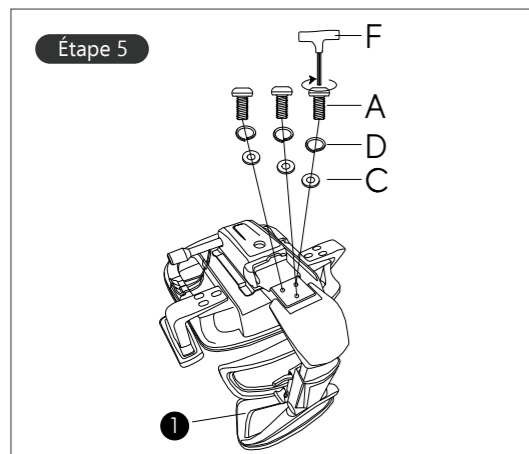
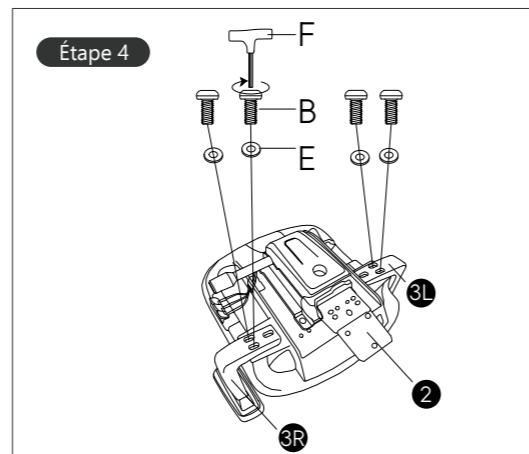
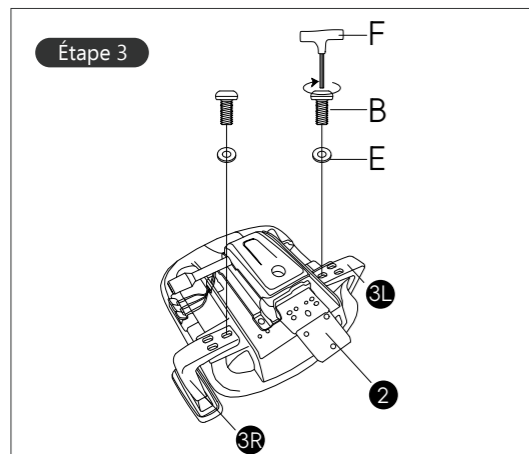
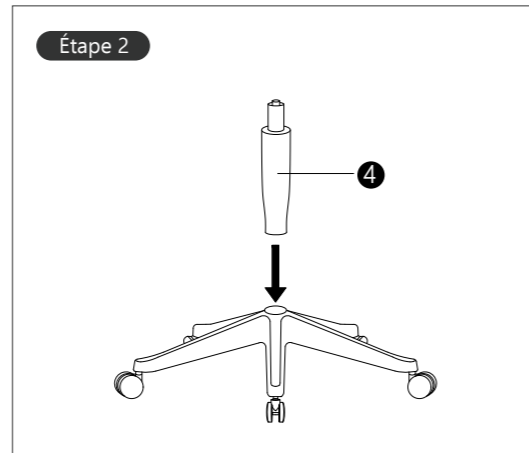
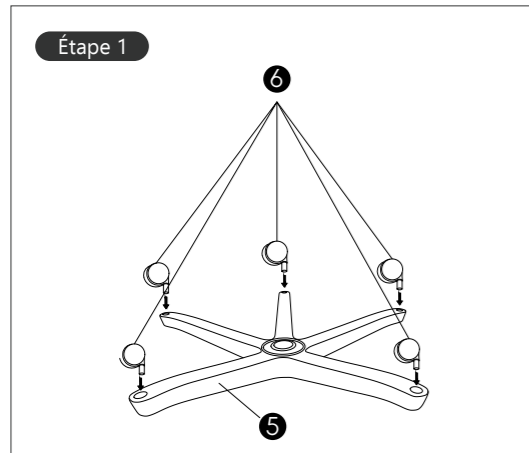

## C'est terminé!

Allez-y, essayez-le. Vous pourriez ressentir ce que nous appelons une sensation d'"ahhh".

C'est tout à fait normal. Vous êtes maintenant parfaitement équipé pour affronter n'importe quoi que la journée de travail puisse vous proposer.

Maintenant, n'ayez pas peur. Montrez-nous comment ça Looks !

# Guide d'utilisation

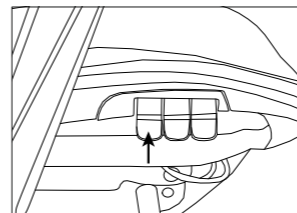

Appuyez vers le haut pour régler la hauteur du siège.

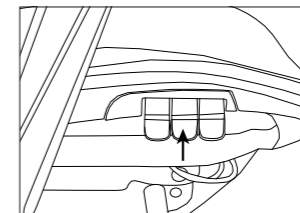

Appuyez vers le haut pour faire glisser le coussin d'avant en arrière.

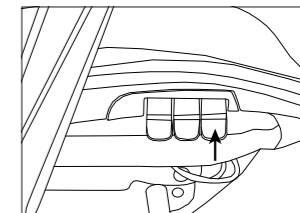

Appuyez vers le haut pour verrouiller, vers le bas pour déverrouiller.

## 01

Réglage en hauteur et en inclinaison de l'appuie-tête

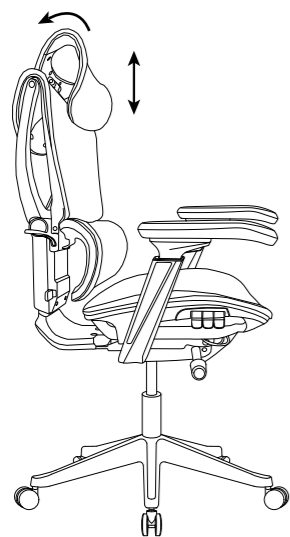

## 02

Réglage en hauteur des accoudoirs et rotation à 20°

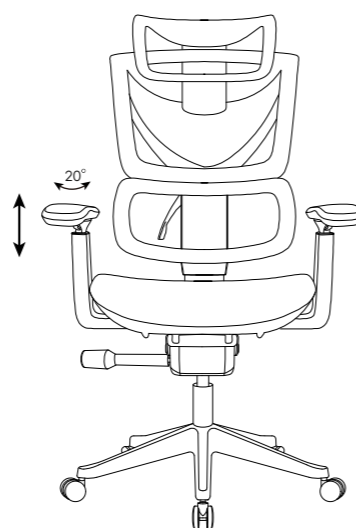

## 03

Réglage avant-arrière des accoudoirs.

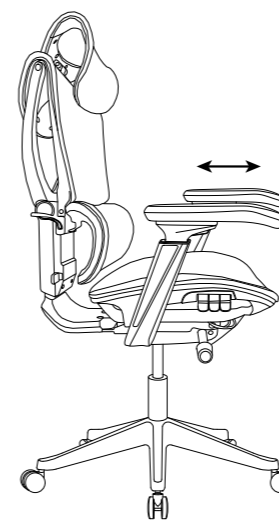

## 04

Tournez la poignée dans le sens horaire pour augmenter la tension, antihoraire pour la diminuer.

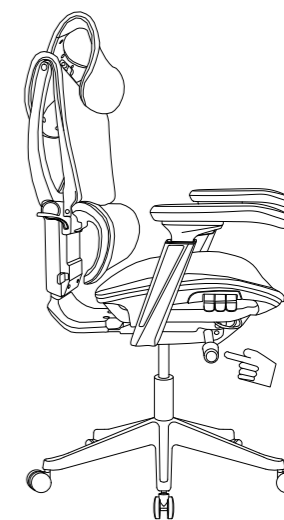

# Guide d'utilisation

## 05

Appuyez sur le petit levier pour régler la hauteur du dossier.

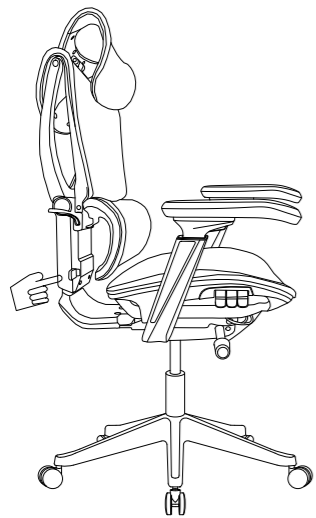

## 06

La position 1 verrouille l'angle du soutien lombaire ; la position 2 permet un réglage dans la plage prévue.

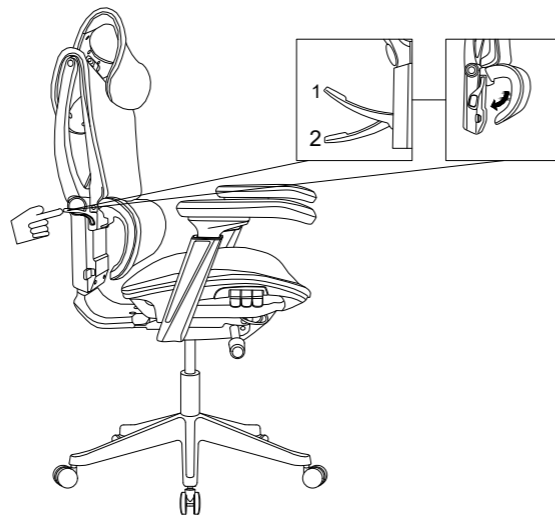

# Avertissement

- Ce produit ne peut être utilisé que pour asseoir une seule personne à la fois.
- Certains vis peuvent être préassemblés. En cas de préassemblage, ignorez les instructions d'assemblage.
- Manipulez avec soin les cylindres et les composants mécaniques. Ils peuvent contenir de la graisse qui pourrait tacher les surfaces de la chaise ou le vêtement en cas de contact.
- Ne pas utiliser cette chaise en tant que tabouret/échelle, ou sur des surfaces de sol inégales.
- Ne pas s'asseoir sur toute partie de la chaise autre que le siège.
- Ne pas utiliser la chaise si tous les boulons, vis et boutons ne sont pas serrés.
- Tous les six mois, assurez-vous que tous les boulons, vis et boutons sont entièrement serrés pour maintenir la stabilité.
- Si des composants manquent, sont endommagés, déformés ou usés, arrêtez l'utilisation et ne les réparez que avec des pièces autorisées par le fabricant.
- Le non-respect de ces avertissements pourrait entraîner de graves blessures.