

Assembly Instructions

Caution: You must read this before you proceed

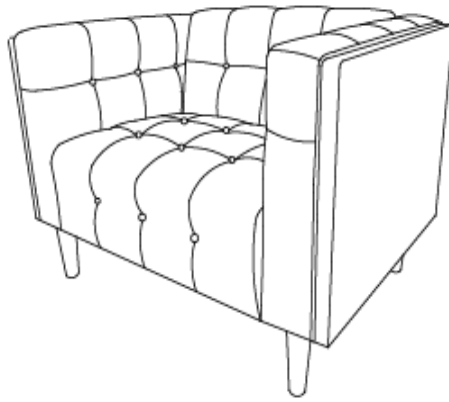

Please look in the seat for hardware packs and legs.

CLUB CHAIR





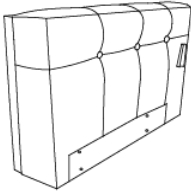
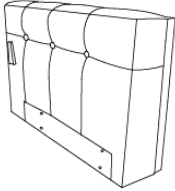

Parts List

Label	Picture	Description	QTY
A	A line drawing of the chair base, showing a rectangular frame with tufting on the top surface.	Chair Base	1
B	A line drawing of the chair backrest, showing a rectangular frame with tufting on the top surface and two small circles at the bottom corners.	Chair Backrest	1

C		Left Arm	1
D		Right Arm	1
E		Wooden Leg with Plastic Gasket	4

Hardware List

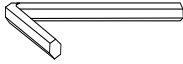
Label	Picture	Description	QTY
①		Plastic Gasket	3
②		Bolt(M8*80mm)	11
③		Washer	11
④		Spring Washer	11
⑤		Allen Key	1

Assembly Preparation

Before Beginning Assembly:

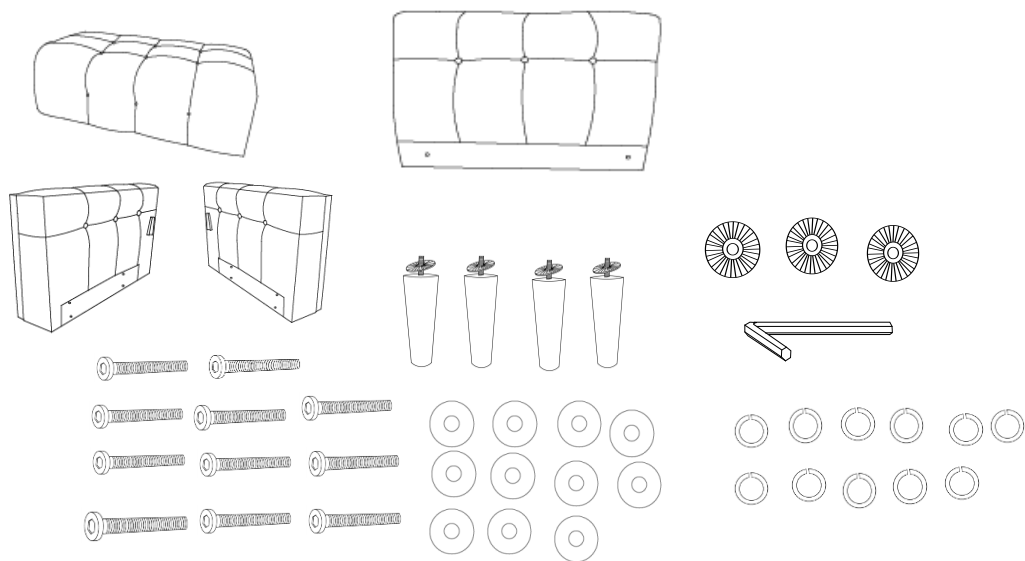

- Read instructions, cover to cover-



- Have 2 adults on hand for assembly-



- Do not assemble on flooring or carpet-



- Assemble on a clean non-marring surface (packing foam)-



- Save all packaging until finished-

Assembly Steps

Overview

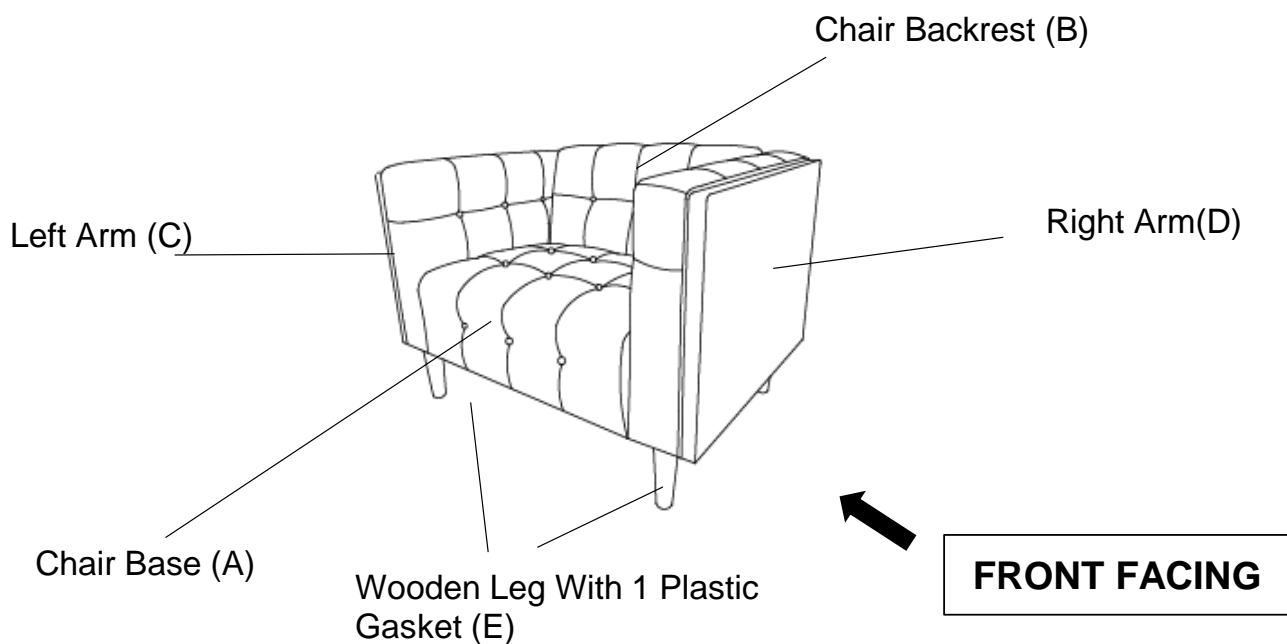

This Club Chair has multiple parts and may require about 30 minutes to assemble. To give you an overview of the Loveseat parts, the above picture is to help you put the various parts into perspective. Please read through the instructions below to familiarise yourself with the parts and steps before assembly.

Step 1

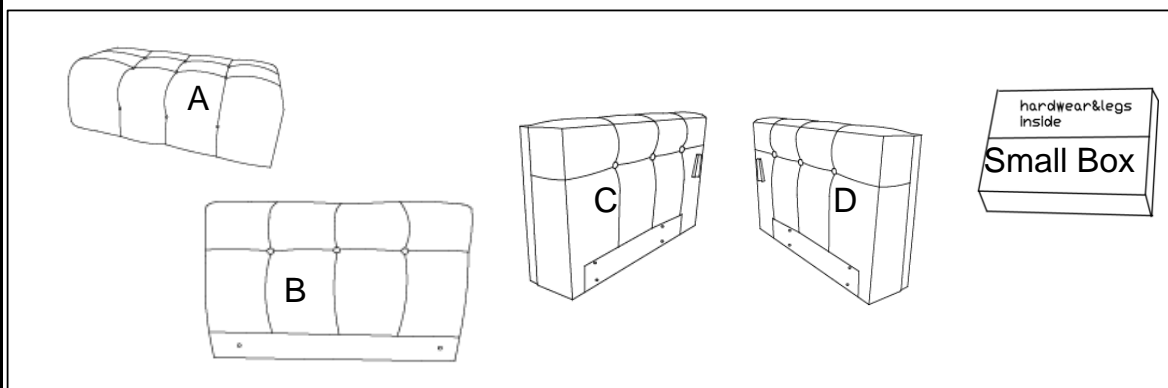
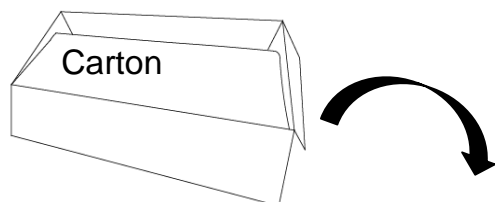

Take the Chair Base (A), Chair Backrest(B), Left Arm (C), Right Arm(D) and a Small Box out from the carton and place them on a clean, non-marring surface.

Step 2

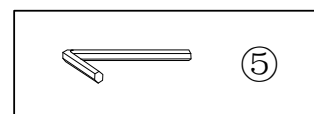
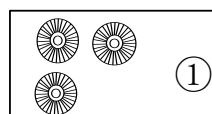
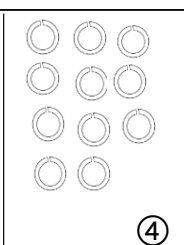
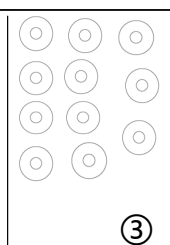
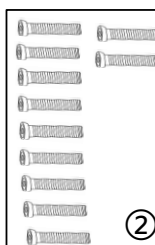
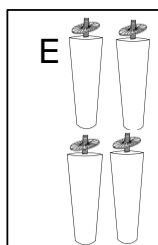
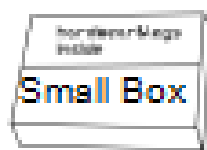

Open the Small Box to take out the Wooden Legs(E) and Hardware as above.

Step 3

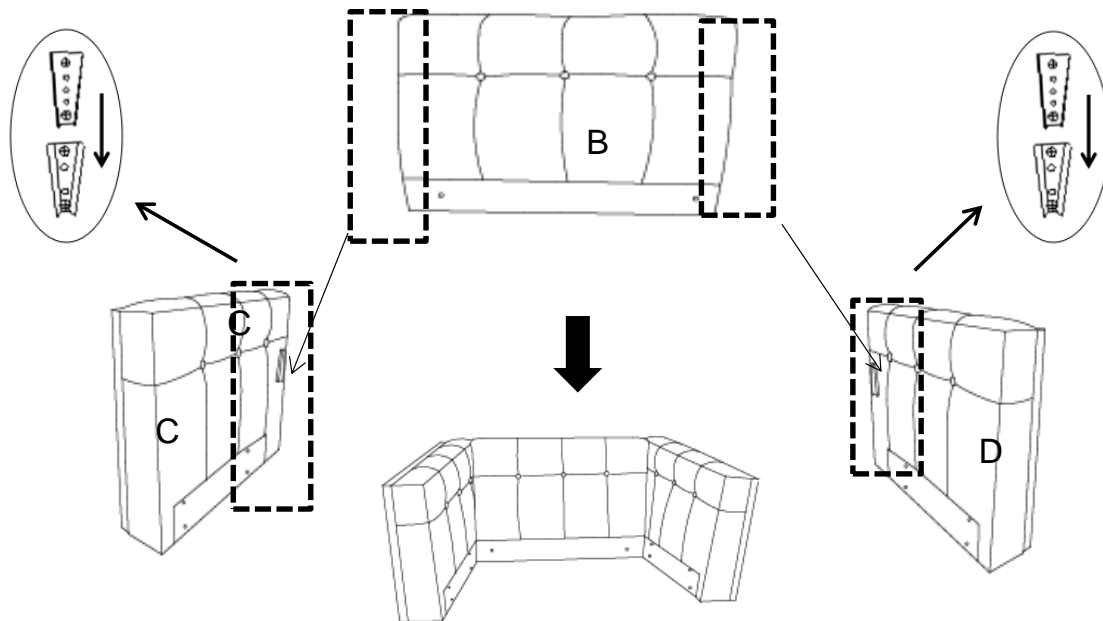

Please protect the Boards of Left Arm(C) and Right Arm(D) when assembling,they are heavy and must with assistance from your adult partner to assemble,avoid bumping and hitting the ground!!!

With assistance from your adult partner, put the Chair Backrest(B) between the Left Arm(C) and Right Arm(D).

Align the mounting brackets on the both sides of Chair Backrest(B) with those on the Left Arm(C) and Right Arm(D) , then slide the Chair Backrest(B) downwards to make sure it locks as pictured.

Please squeeze the armrest properly against the backrest to ensure that the inserts can be assembled smoothly.

Step 4

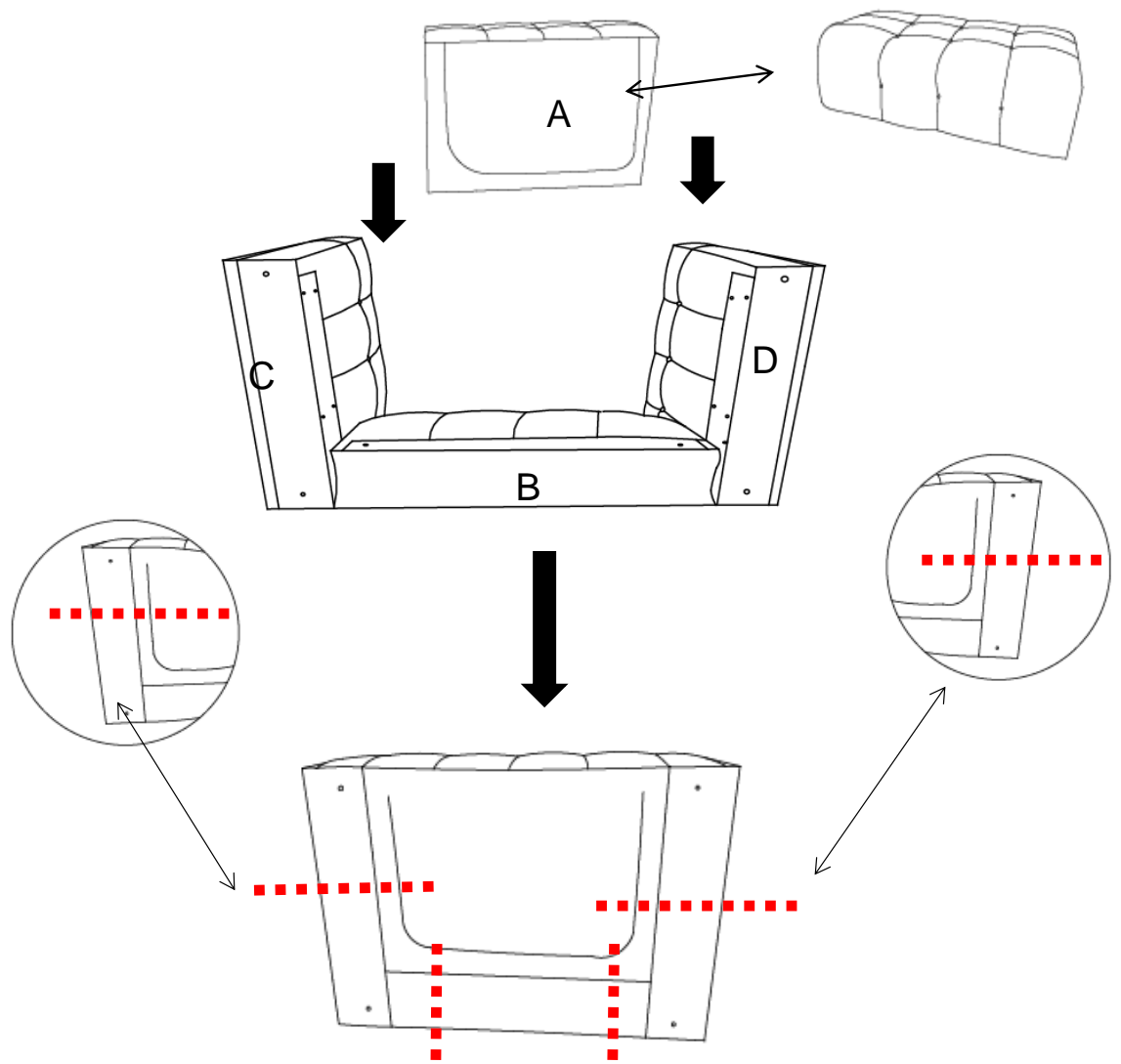

With assistance from your adult partner, align the mounting positions of Chair Base(A) to mounting positions on the Chair Backrest(B) and both sides of the Left Arm(C) and Right Arm(D), make sure the bottom of the Chair Base(A), Chair Backrest(B), Left Arm(C) and Right Arm(D) at the same level.

Step 5

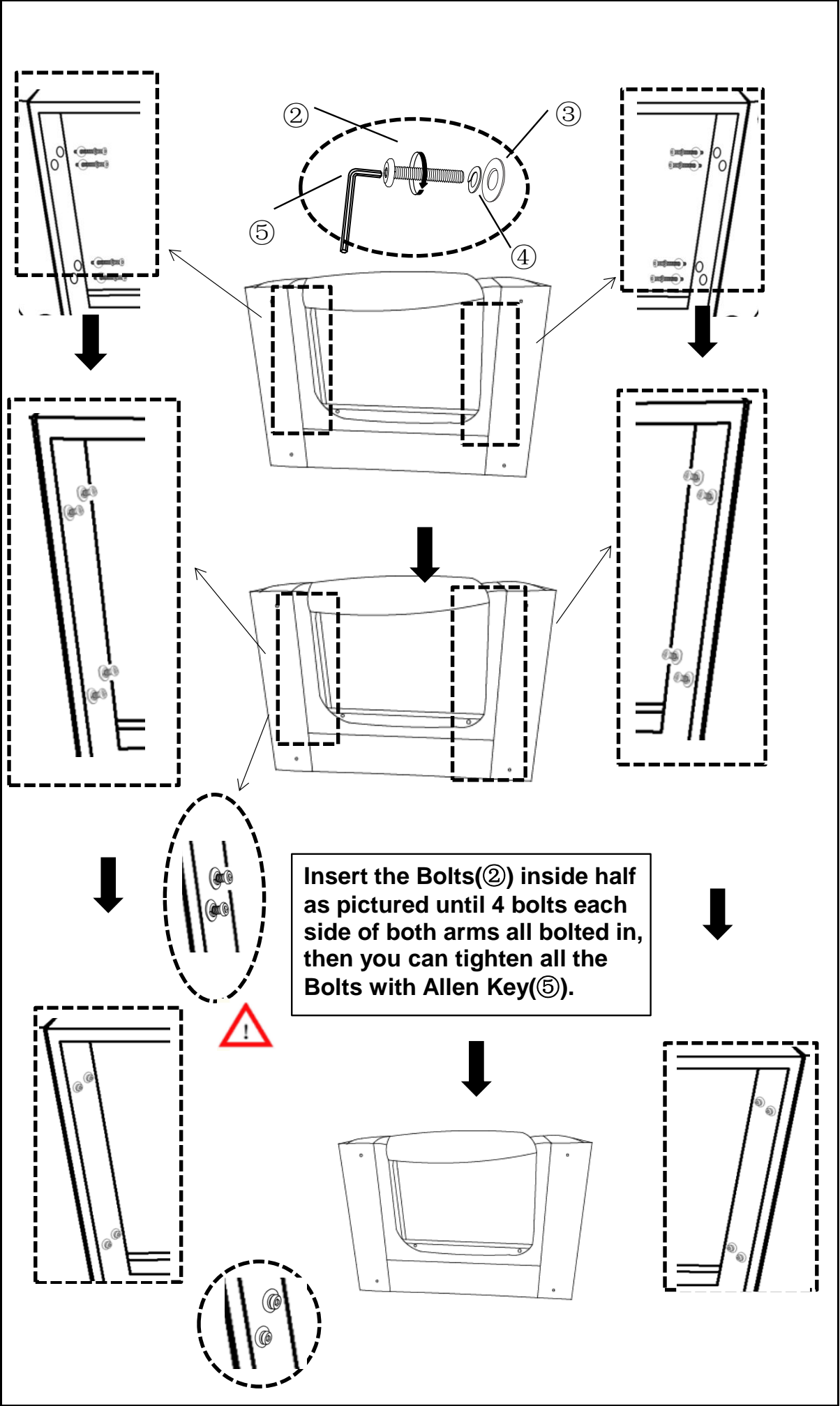

Insert the Bolts(2) inside half as pictured until 4 bolts each side of both arms all bolted in, then you can tighten all the Bolts with Allen Key(5).



With assistance from your adult partner, place the whole product on a clean, non-marring surface.

Open the non-woven cover under both sides of Chair Base(A).

Then using the Allen Key(⑤) secure Chair Base(A) to the Left Arm(C) and Right Arm(D) with Bolts(②), Spring Washer(④) and Washers(③).

Please don't tighten the Bolts, just bolt them half-way until all are bolted in, then tighten all the Bolts with the Allen Key(⑤).

Note: The bottom of the Sofa Base(A) frame must be aligned with the bottom of the handrail.

Step 6

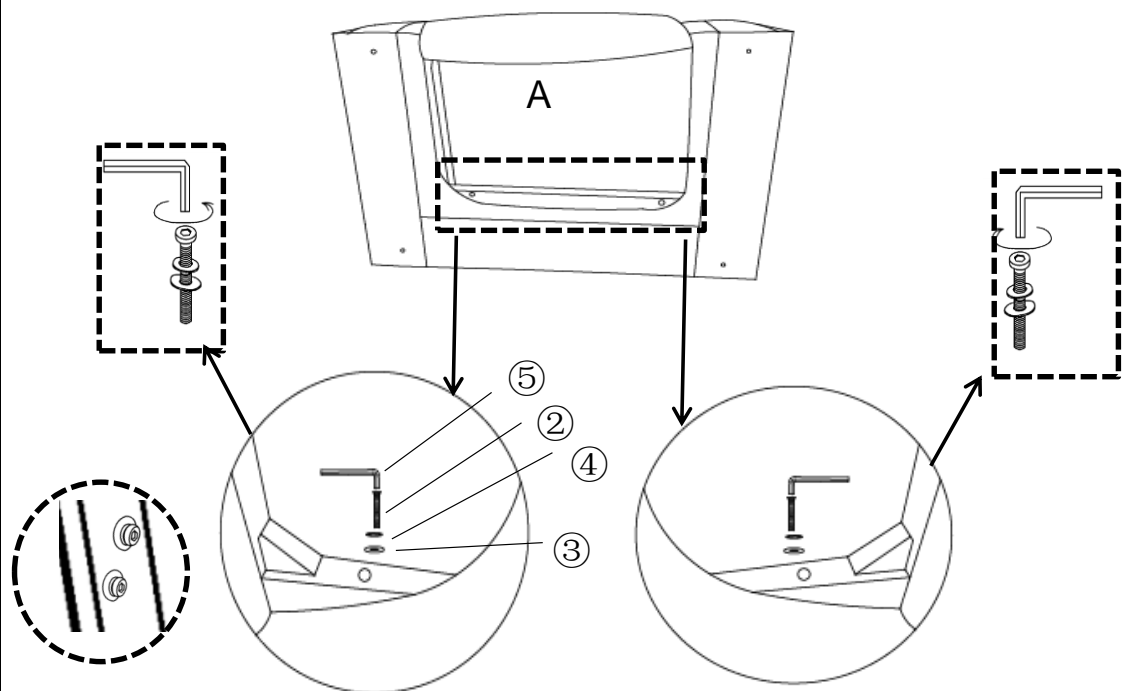

Insert the 2 Bolts(②) half-way until all Bolts are bolted in with Allen Key(⑤), then you can tight them.

Using the Allen Key(⑤) secure Chair Base(A) to the front-bottom of Chair Backrest(B) with the Bolts(②), Spring Ring(④) and Washers(③).

Insert the 2 Bolts(②) half-way starting one by one as pictured.

Then tighten the Bolts(②) with the Allen Key(⑤).

Close the non-woven fabric under the Chair Base(A) with Velcro.

Step 7

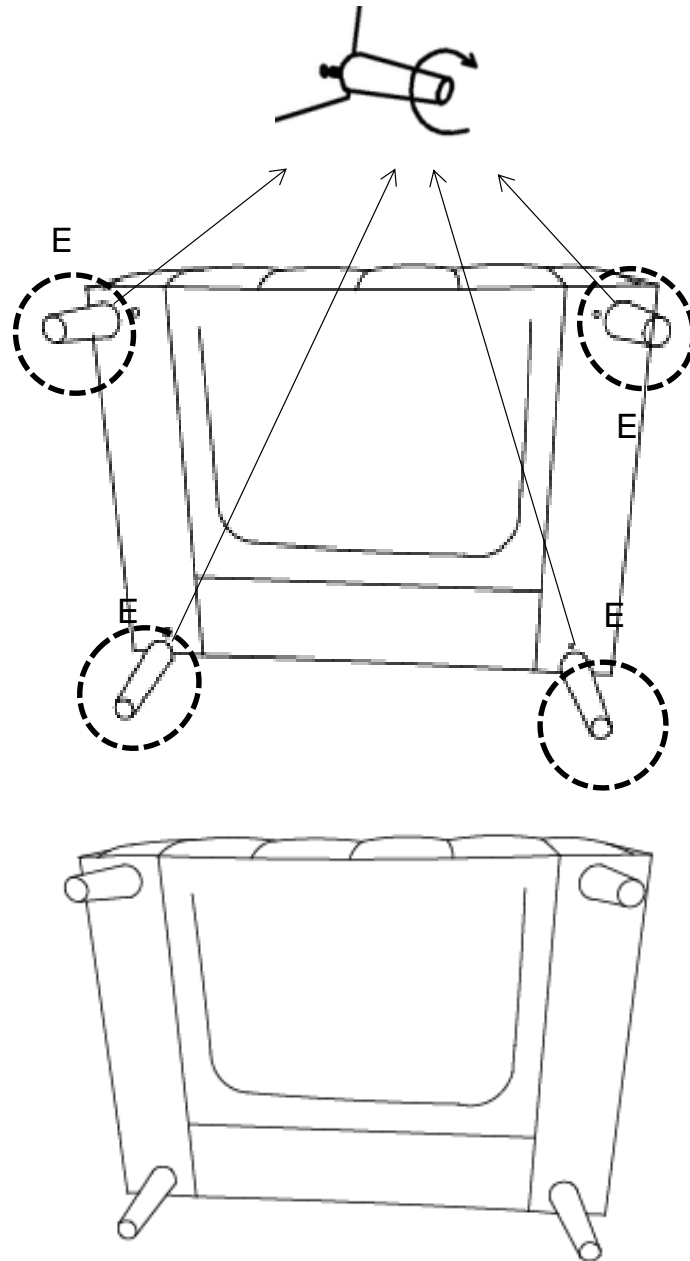

Install the Wooden Legs With 1 Plastic Gasket(E) to the bottom of the Chair by placing one Gasket(①) on the threaded stem.

Tighten by turning the Leg clockwise.

Note: The use of Gaskets are OPTIONAL and are especially useful to help alleviate slight wobbles. Some Legs may need more than one Gasket whilst some Legs may not need any.

Step 8

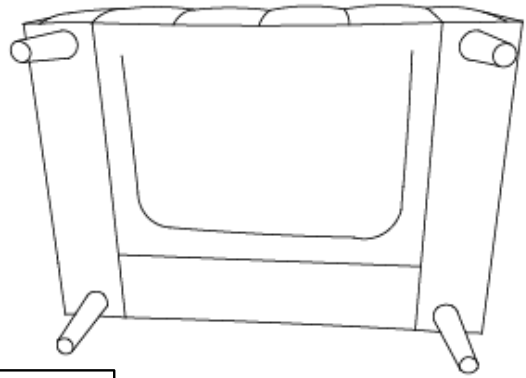



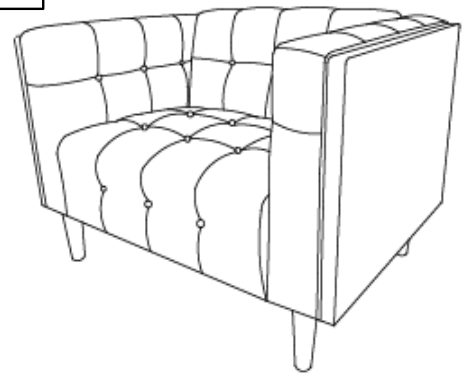







Don't turn the Club Chair directly, you need to lift the Chair up then put it down gently (in order to make sure the Legs or Legs support are not be damaged by any incorrect operation).



Make sure all of the parts connected to the right position and strong enough.
Now your Club Chair is ready for use.
This Club Chair can only be used on a flat, level surface.

Care & Maintenance

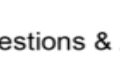
	<ul style="list-style-type: none"> Furniture may scratch floors. We recommend using furniture pads to protect your floors.
	<ul style="list-style-type: none"> Do not put hot items directly on furniture surface.
	<ul style="list-style-type: none"> Do not clean furniture with harsh cleansers or polish.
	<ul style="list-style-type: none"> Do not place furniture under direct sunlight.
	<ul style="list-style-type: none"> Do not place furniture near heating or cooling vents.
	<ul style="list-style-type: none"> Do not write on furniture without a padded barrier to protect the surface.
	<ul style="list-style-type: none"> Do not place furniture outside . For indoor use only.
	<ul style="list-style-type: none"> Not for commercial use. For residential use only.
	<ul style="list-style-type: none"> Stains may be removed with mild soap solution and damp cloth.
	<ul style="list-style-type: none"> Children should not climb or jump on the furniture.
	<ul style="list-style-type: none"> Dust and pick-up spills using a clean, non-colored, lint-free cloth.

Questions & Answers about Proposition 65

• What is Proposition 65?

Proposition 65 requires businesses to provide warnings to Californians about significant exposures to chemicals that cause cancer, birth defects or other reproductive harm. These chemicals can be in the products that Californians purchase, in their homes or workplaces, or that are released into the environment. By requiring that this information be provided, Proposition 65 enables Californians to make informed decisions about their exposures to these chemicals.

Proposition 65 also prohibits California businesses from knowingly discharging significant amounts of listed chemicals into sources of drinking water.

Proposition 65 requires California to publish a list of chemicals known to cause cancer, birth defects or other reproductive harm. This list, which must be updated at least once a year, has grown to include approximately 900 chemicals since it was first published in 1987.

• What types of chemicals are on the Proposition 65 list?

The list contains a wide range of naturally occurring and synthetic chemicals that include additives or ingredients in pesticides, common household products, food, drugs, dyes, or solvents. Listed chemicals may also be used in manufacturing and construction, or they may be byproducts of chemical processes, such as motor vehicle exhaust.

• What does a warning mean?

If a warning is placed on a product label or posted or distributed at a workplace, a business, or in rental housing, the business issuing the warning is aware or believes that it is exposing individuals to one or more listed chemicals.

By law, a warning must be given for listed chemicals unless the exposure is low enough to pose no significant risk of cancer or is significantly below levels observed to cause birth defects or other reproductive harm.

• - - - - -

It
c
4