

**SINGLE SWING - BSW01**  
FOR CHILDREN AGED 3 TO 10 YEARS

**SAFETY GUIDELINES**

**Warnings**

**Only for domestic use. This product has not been designed for commercial use in play centers, nurseries etc.**

**Only suitable for outdoor use.**

**Not for children with a body weight over 45kg. Only one child per seat at any one time.**

**Not for children under 3 years due to small component which may cause choking hazard.**

This equipment must be assembled and checked by an adult. Two adults may be required to assemble this product.

Adult supervision is required at all times.

Check all nuts, bolts and fittings for tightness and tighten if required.

Check all coverings for bolts and sharp edges and replace when required.

Check swing seats, chain, ropes and other means of attachments relevant to your product for evidence of deterioration. Replace when required in accordance with the manufacturers instructions if necessary.

Place the product on level surface at least 2 metres from any structure or obstruction such as a fence, garage, house, wall, overhanging branches, laundry line or electrical wires.

The items MUST be anchored firmly into the ground.

DO NOT install the product over concrete, asphalt or any hard surface.

DO NOT orientate the product directly towards the sun.

Leave all fittings finger tight until assembly is complete, for ease of construction. Then tighten firmly.

Children should not wear cycle helmets whilst on this equipment.

Do not allow children to stand on any swing seats, glider seats or slide chutes relevant to your product.

Do not allow children to jump or climb off any moving equipment.

Do not twist swing ropes or wrap them over the top bar.

Do not allow loose, hooded or baggy clothes to be worn as children can get trapped and may be unable to free themselves.

Do not allow children to climb on parts of this equipment not intended for this purpose.

Do not allow children to wander into the play area whilst the equipment is in use.

Glider and swings must not exceed an angle of 60 degrees from the ground.

Regularly check the item for wear and damage, removing the item from use when necessary until replacement parts are fitted.

Failure to assemble and maintain this item as per instruction may cause injury to the user.

Please keep the instructions in a safe place for future reference.

The minimum clearance between the swing seat and ground level should be 350mm.

Please contact our customer services department if you have any problems.

Inspect all parts of this product every 6 months following purchase. If any parts look worn or you find any problems, please contact us for replacements and do not use product until problem has been corrected.

Do not modify this item

**SWING PARTS LIST**

- 1 CENTRE BAR
  - 2 "LEFT-HAND" TYPE TOP LEG (X2)
  - 3 "RIGHT-HAND" TYPE TOP LEG (X2)
  - 4 BOTTOM LEG (X4)
  - 5 SIDE STAY BAR (X2)
  - 6 SWING SEAT
  - 7 GROUND PEG (X4)
  - F1 M8 U-BOLT (X2)
  - F2 42MM SOCKET HEAD M6 BOLT (X4)
  - F3 52MM SOCKET HEAD M6 BOLT (X4)
  - 8 SPANNER (X1)
  - 9 ALLEN KEY (X1)
- 

**IMPORTANT:** Make sure you read the safety notice on the front page and always supervise children while they are playing on the equipment. Once assembly is completed carefully check equipment. In the unlikely event that you do find any problems, please contact us. Do not allow children to use this product until the problem has been corrected.

**STEP 1**  
Frame & Swing Assembly

- F1 M8 U-BOLT (X2)
- 8 SPANNER (X1)
- 9 ALLEN KEY (X1)

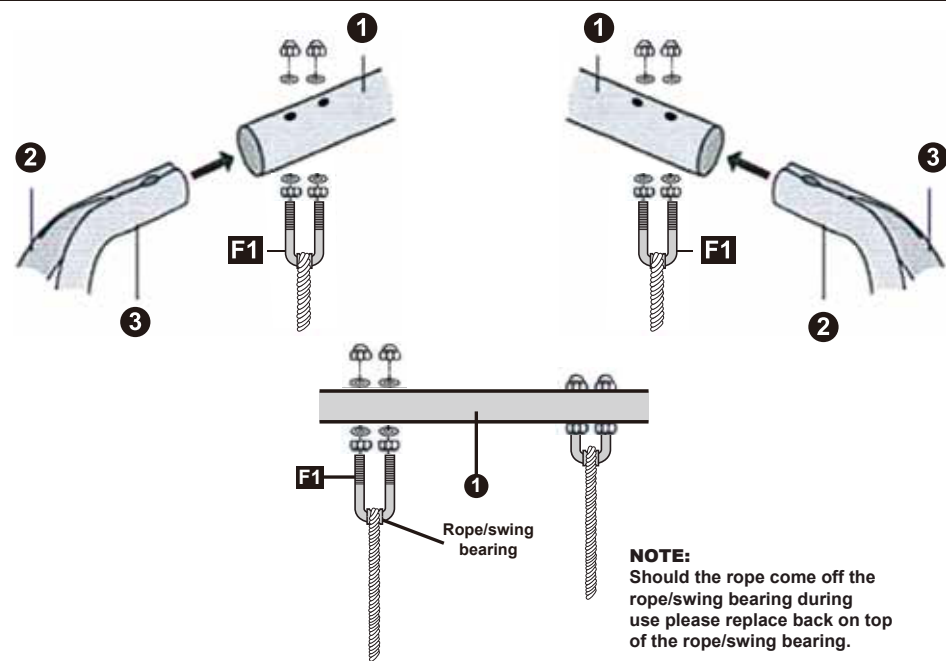

**STEP 2**  
Frame & Swing Assembly

- F2 42MM SOCKET HEAD M6 BOLT
- F3 52MM SOCKET HEAD M6 BOLT

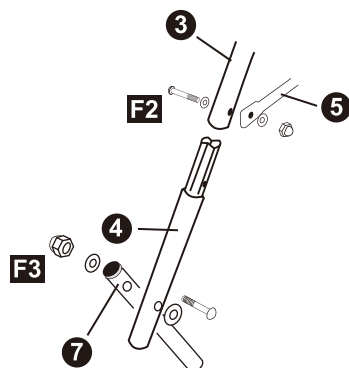

**STEP 3**  
Anchoring the swing to the ground

**IMPORTANT:** For safety reasons this swing MUST be anchored into the ground. We recommend that it is concreted in. If you are uncertain about this procedure, telephone our helpline number.

