

Assembly Instruction

——TAB128WT——

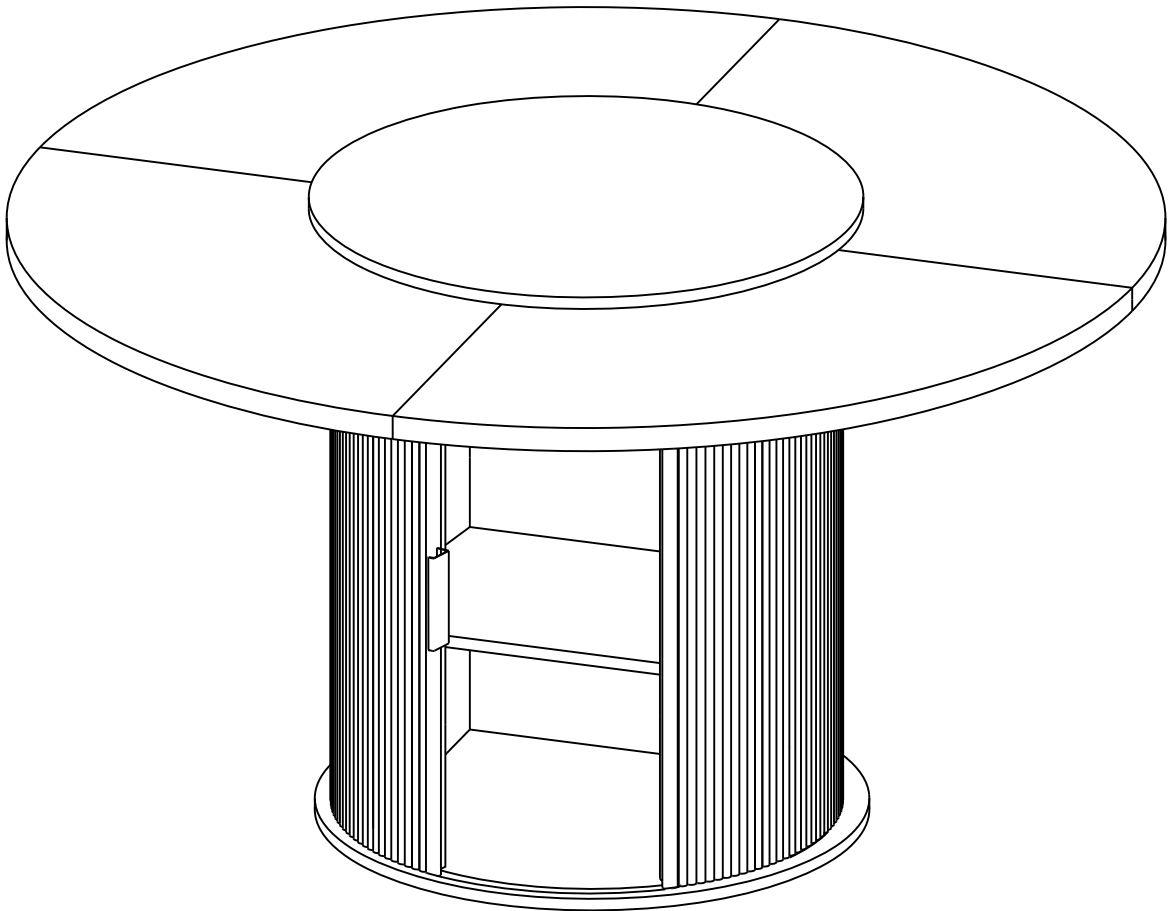

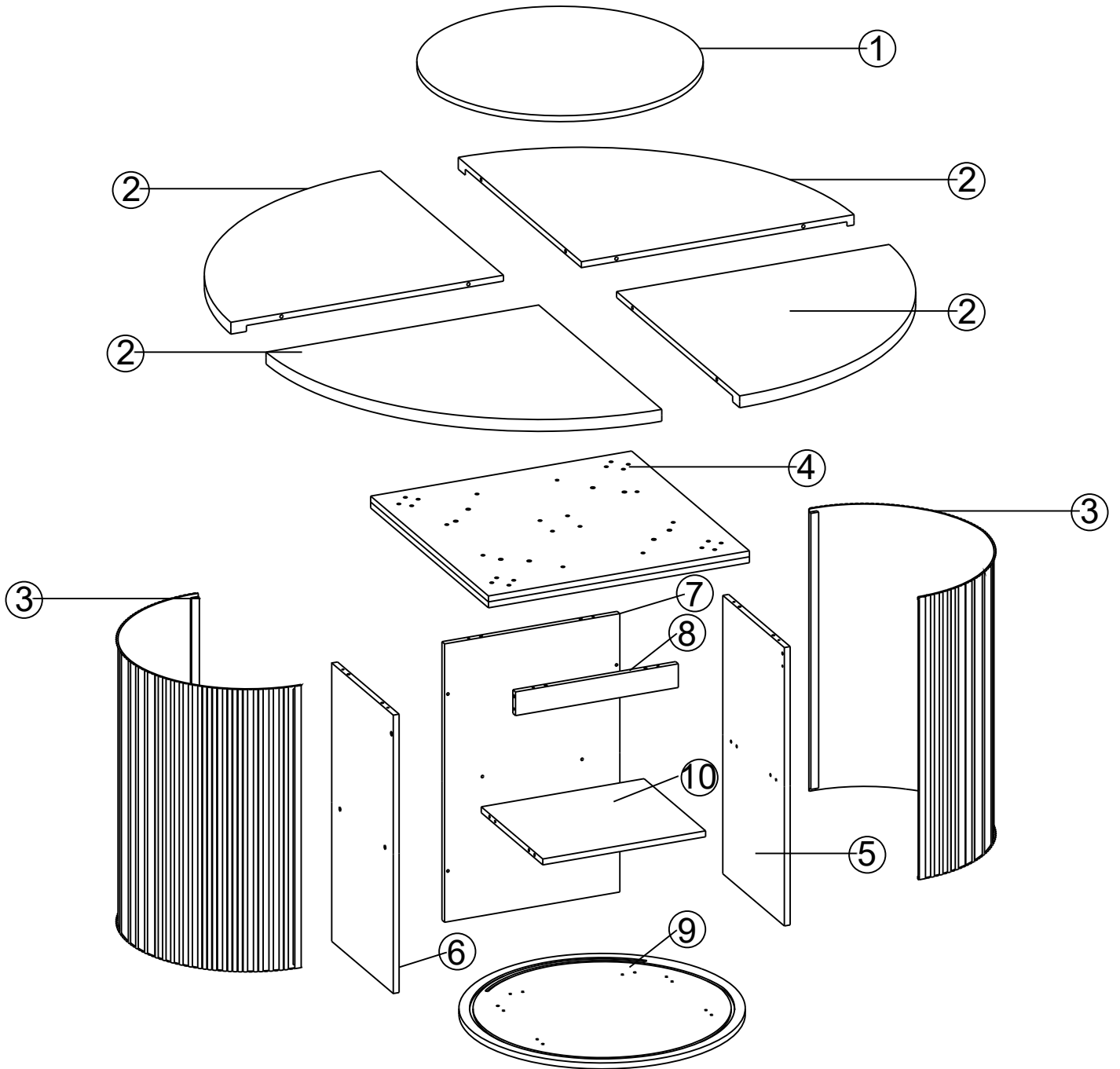





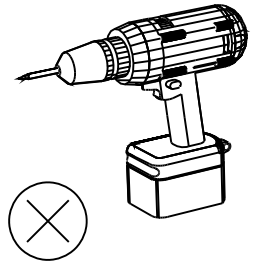
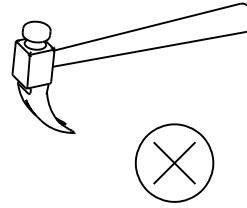
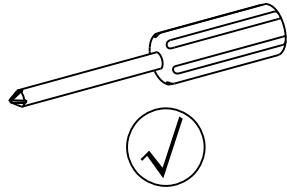
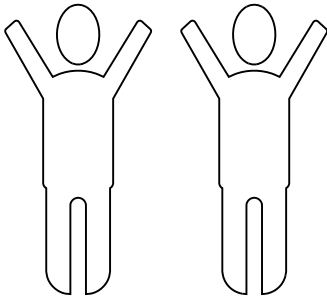

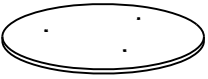

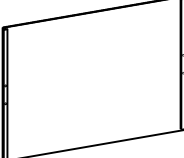
Parts List(EN)/Teile Liste(DE)



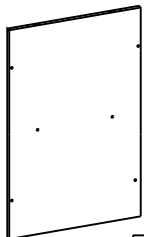

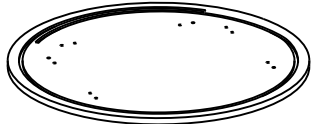



Parts List (EN) / Teile Liste (DE)

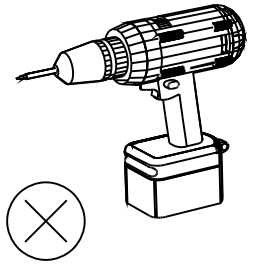
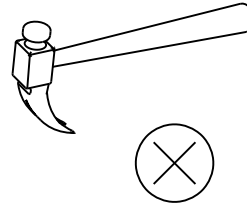
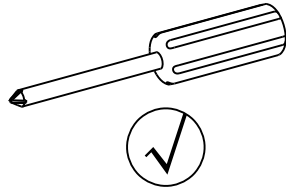
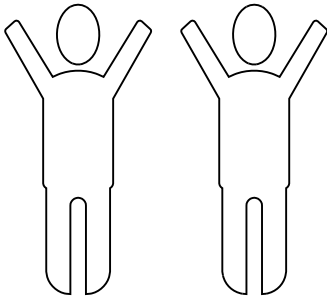

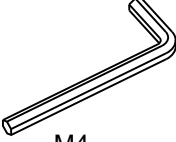
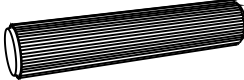
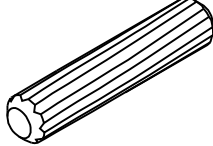
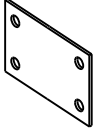
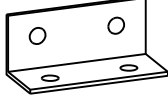
<p>①</p>  <p>1PCS</p>	<p>②</p>  <p>4PCS</p>	<p>③</p>  <p>2PCS</p>	<p>④</p>  <p>1PCS</p>
<p>⑤</p>  <p>1PCS</p>	<p>⑥</p>  <p>1PCS</p>	<p>⑦</p>  <p>1PCS</p>	<p>⑧</p>  <p>1PCS</p>
<p>⑨</p>  <p>1PCS</p>	<p>⑩</p>  <p>1PCS</p>		

Parts List(EN)/Teile Liste(DE)

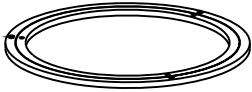
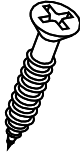
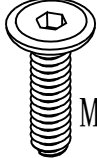



<p>A</p>  <p>M4</p> <p>1PCS</p>	<p>B</p>  <p>∅8*30mm</p> <p>8+2PCS</p>	<p>C</p>  <p>22+3PCS</p>
<p>D</p>  <p>4PCS</p>	<p>L</p>  <p>4PCS</p>	<p>M</p>  <p>∅3.5*12mm</p> <p>18+2PCS</p>
<p>N</p>  <p>1PCS</p>	<p>P</p>  <p>ST5*50mm</p> <p>24+2PCS</p>	<p>O</p>  <p>1PCS</p>
<p>Q</p>  <p>ST3.5*25mm</p> <p>3+1PCS</p>	<p>K</p>  <p>M6*35</p> <p>28+2PCS</p>	<p>Z</p>  <p>M6*12</p> <p>16+1sets</p>

Assembly Steps (EN) /Montageschritte (DE)

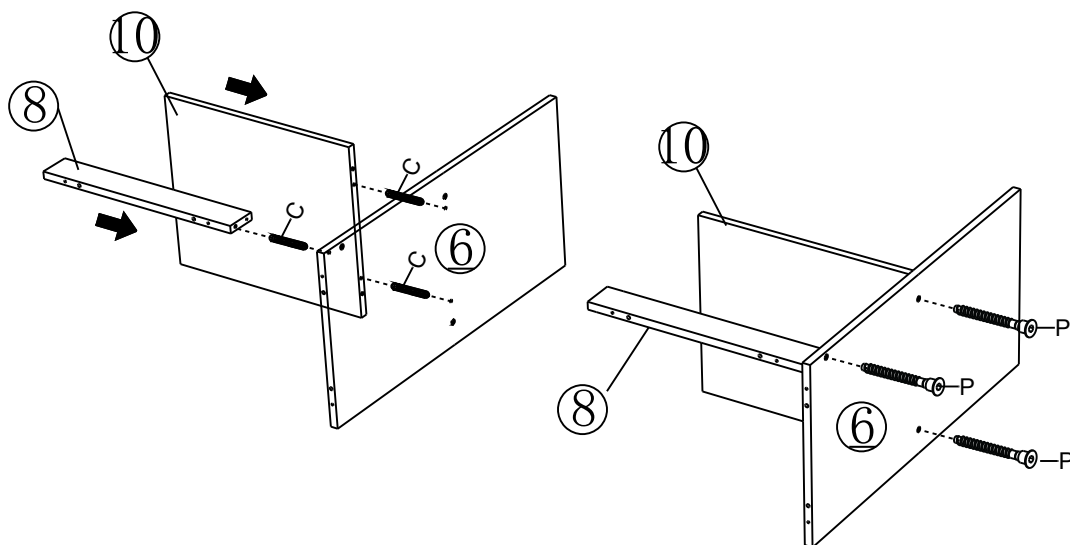

Step 1

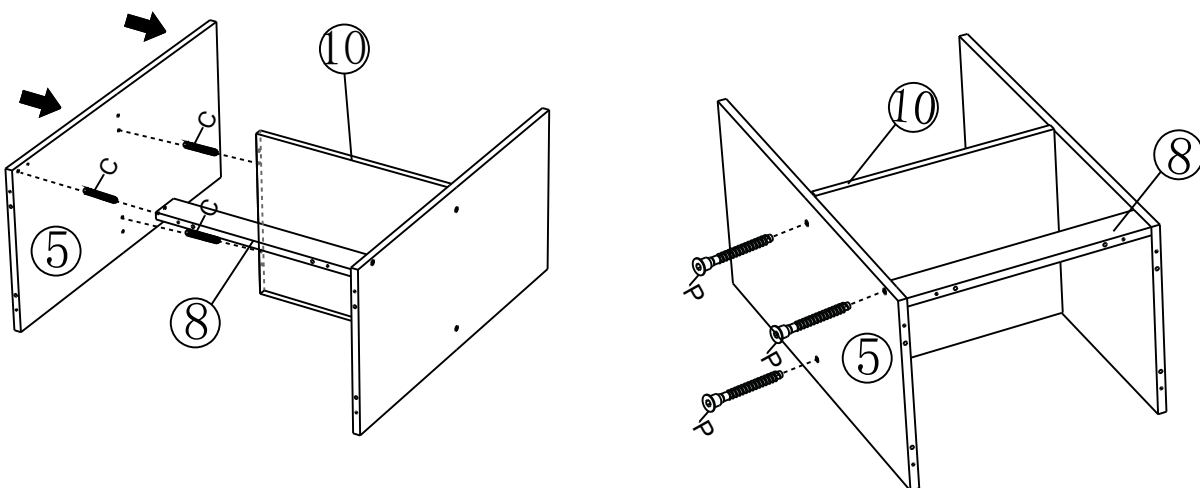

	Px3pcs
	Cx3pcs

Step 2



	Px3pcs
	Cx3pcs

Assembly Steps (EN) /Montageschritte (DE)

Step 3

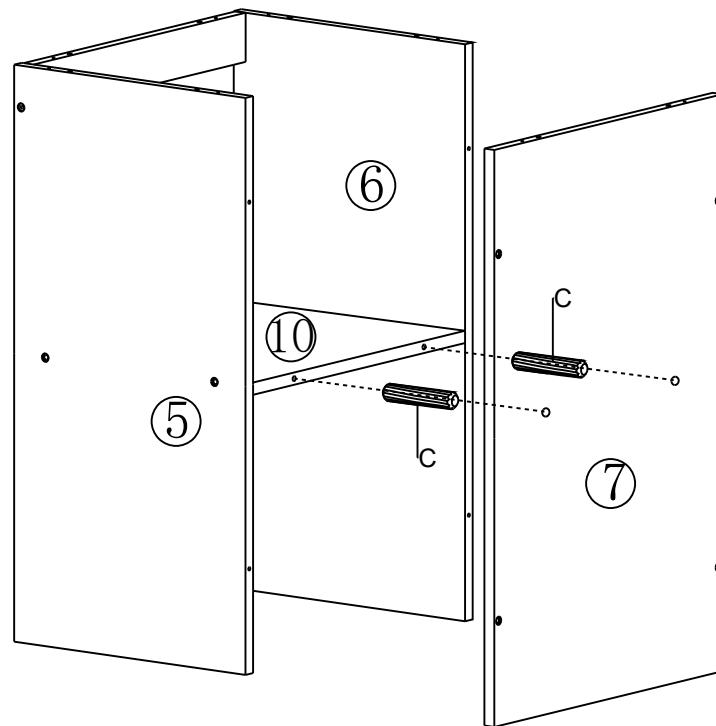

Cx2pcs

Step 4

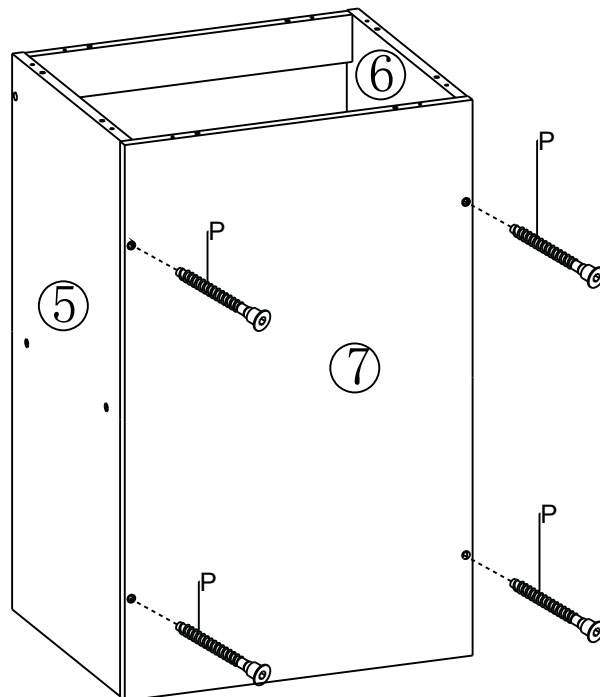

Px4pcs

Assembly Steps (EN) /Montageschritte (DE)

Step 5

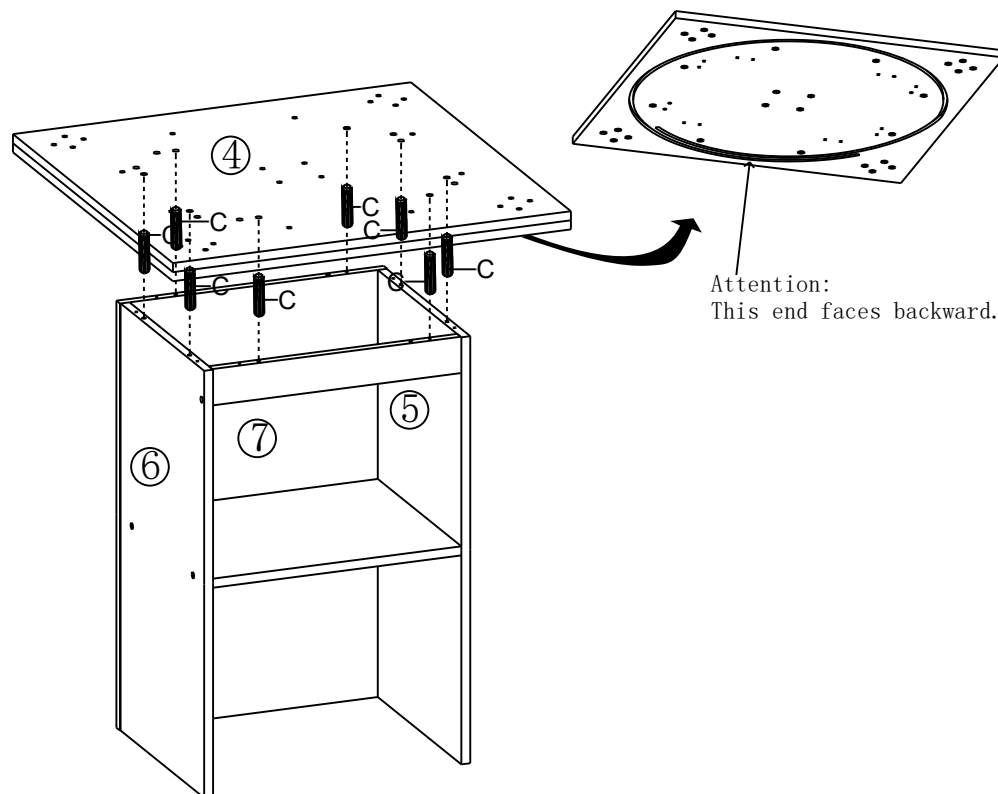

Cx8pcs

Step 6

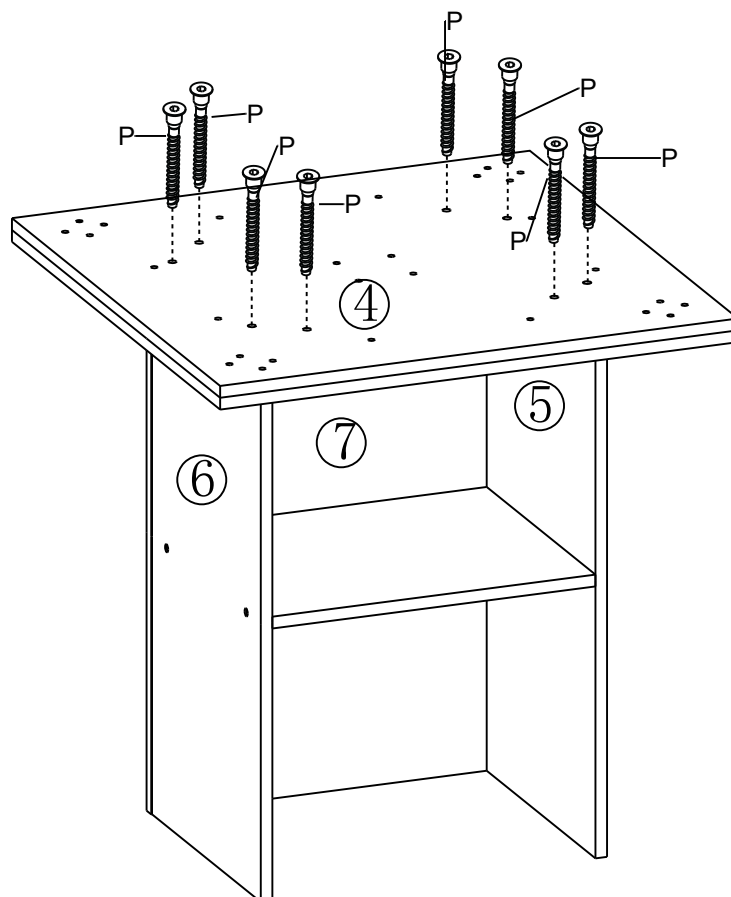

Px8pcs

Assembly Steps (EN) /Montageschritte (DE)

Step 7

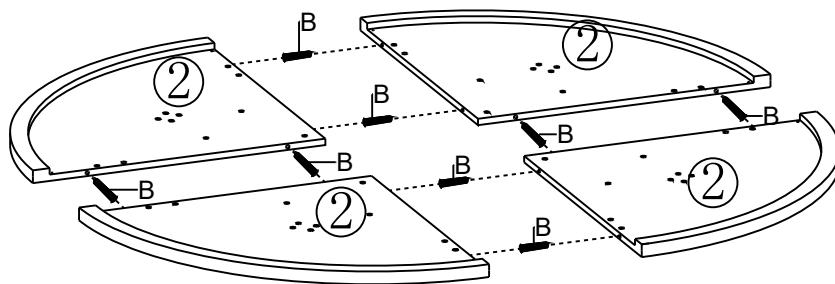

Bx8pcs

Step 8

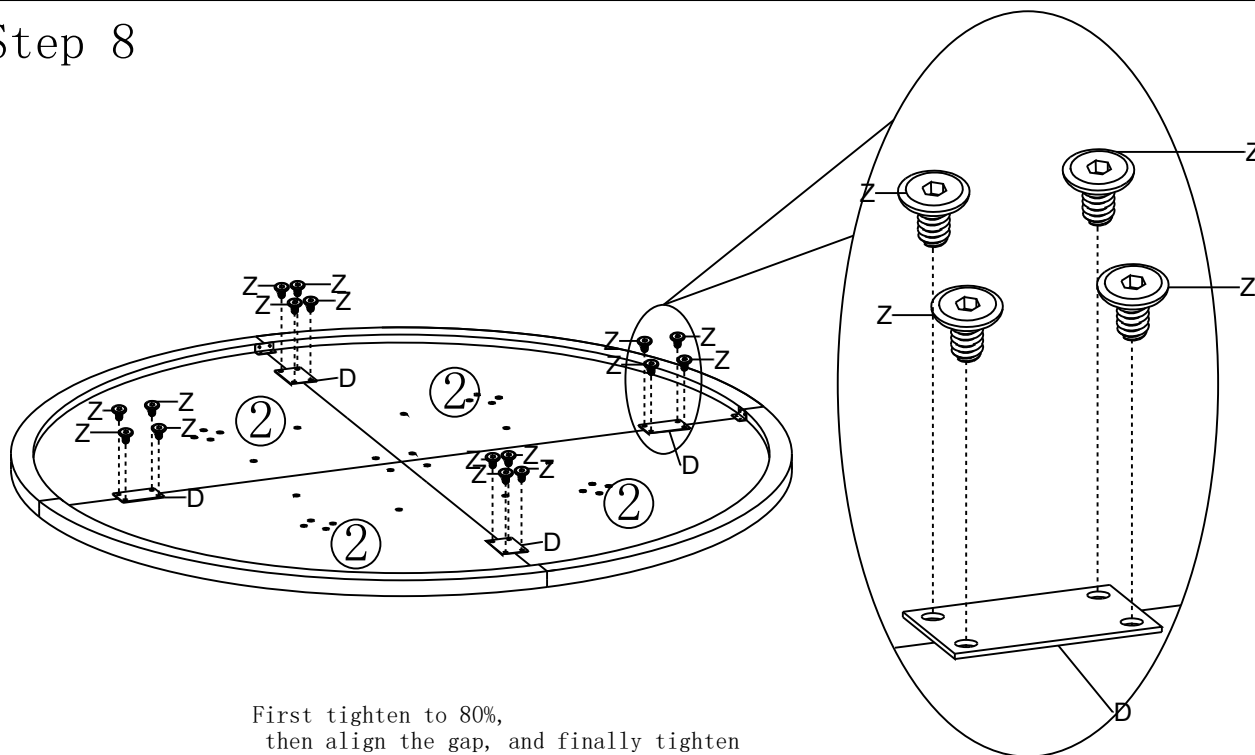

First tighten to 80%,
then align the gap, and finally tighten
all screws completely.



Dx4pcs





Zx16pcs

Assembly Steps (EN) /Montageschritte (DE)

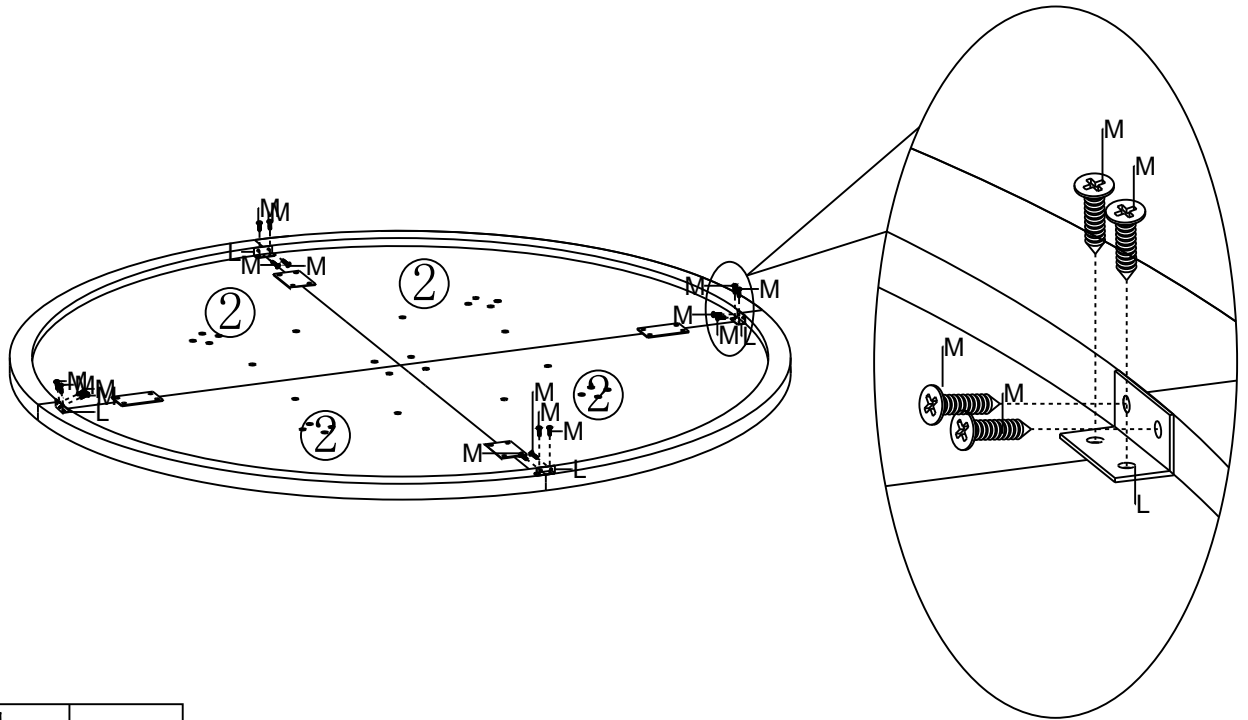
Step 9



	Lx4pcs
	Mx16pcs

Step 10

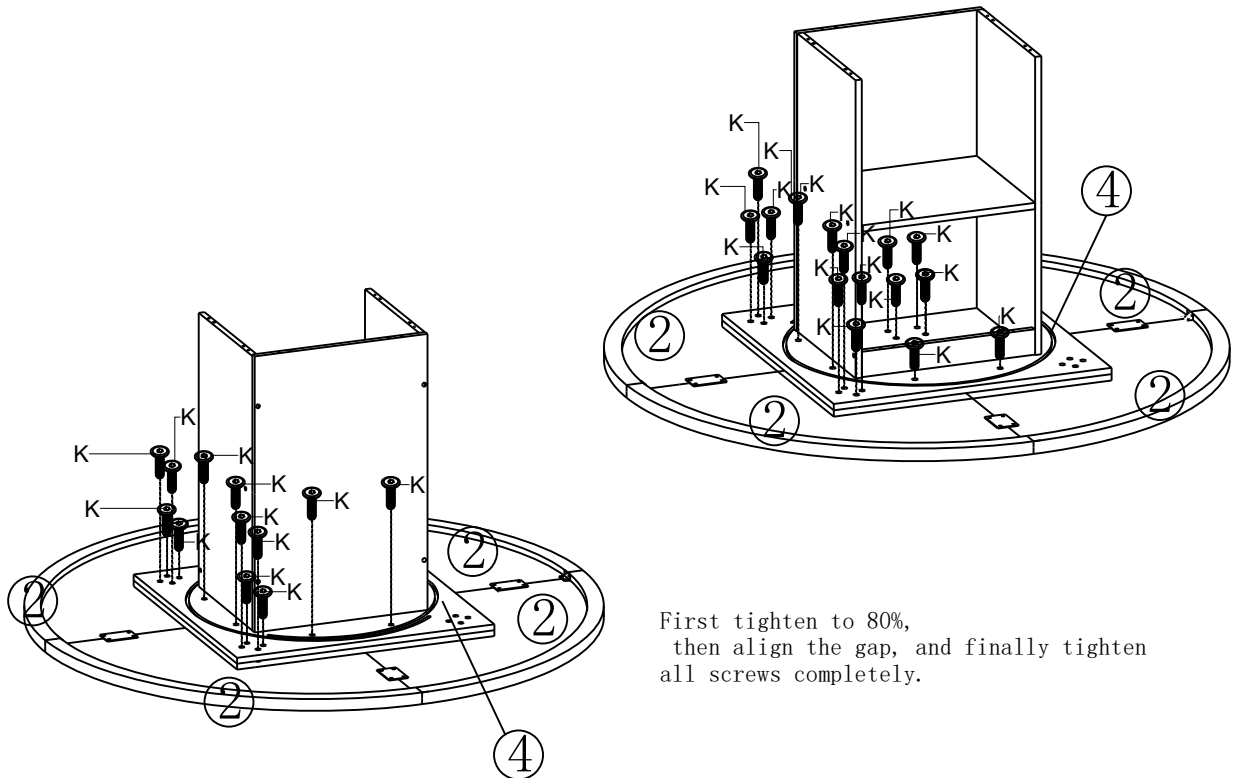

First tighten to 80%,
then align the gap, and finally tighten
all screws completely.

	Kx28pcs
---	---------

Assembly Steps (EN) /Montageschritte (DE)

Step 11

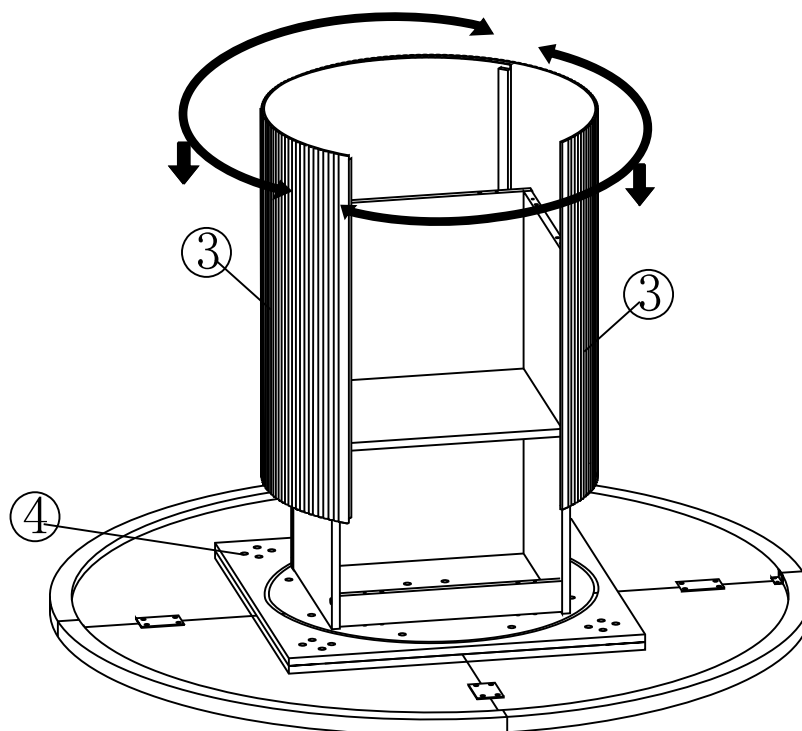

Put No. 3 into the slot of No. 4.

Step 12

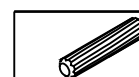
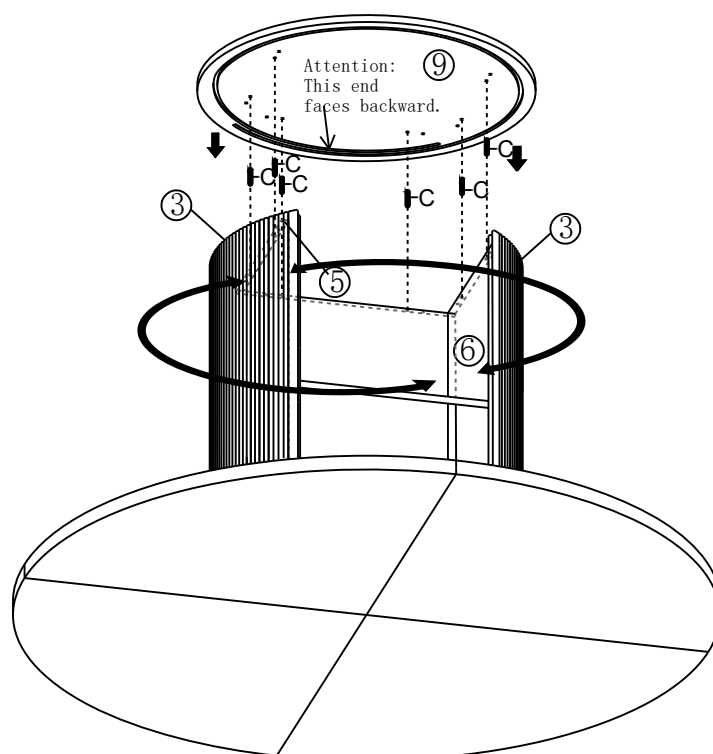

Cx6pcs

Assembly Steps (EN) /Montageschritte (DE)

Step 13

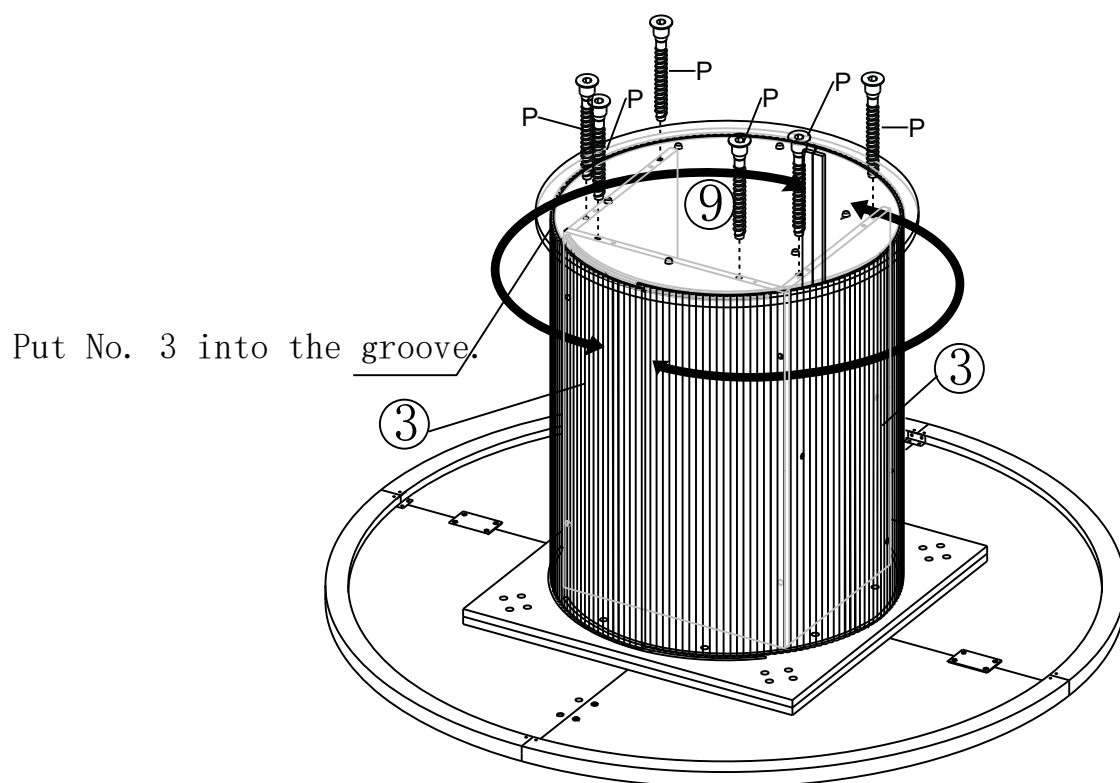

Px6pcs

Step 14

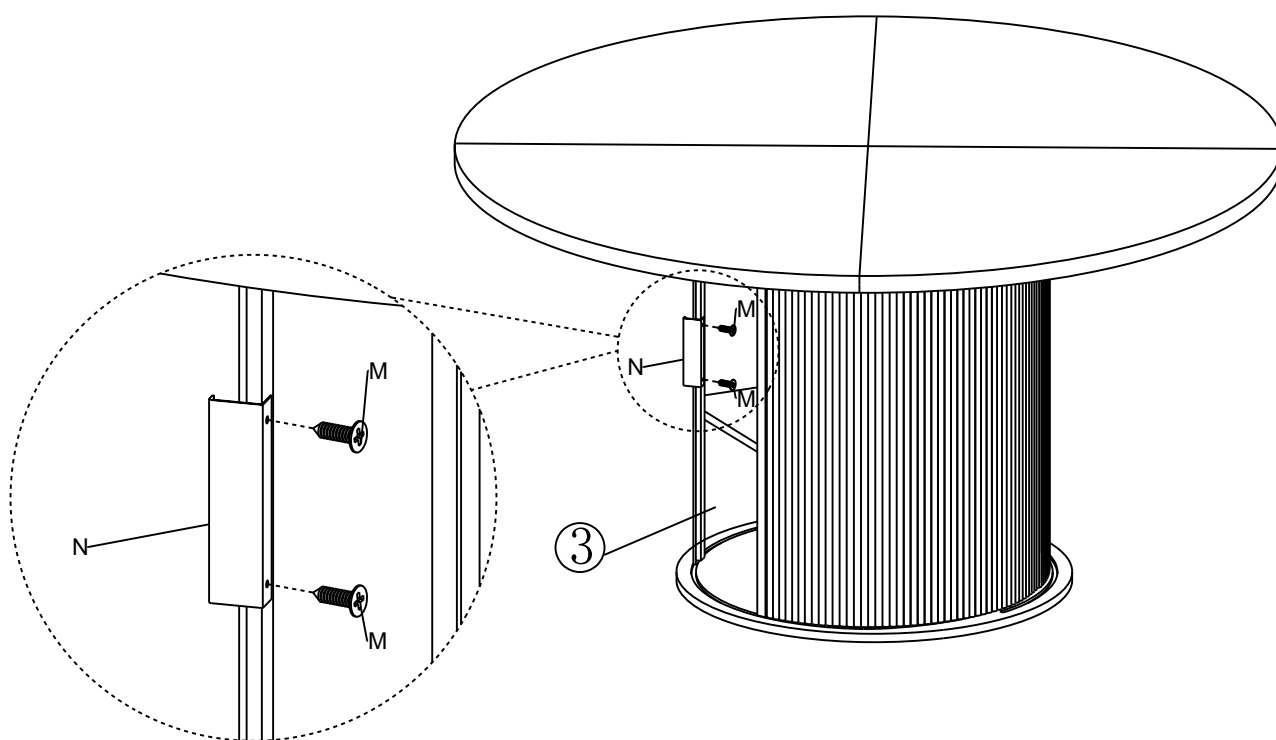

Mx2pcs

Assembly Steps (EN) /Montageschritte (DE)

Step 15

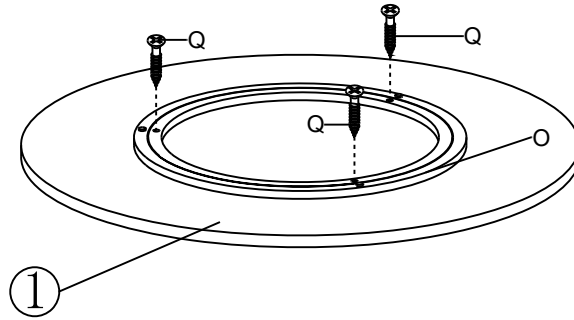

	0x1pcs
	Qx3pcs

Step 16

