

Assembly Instructions

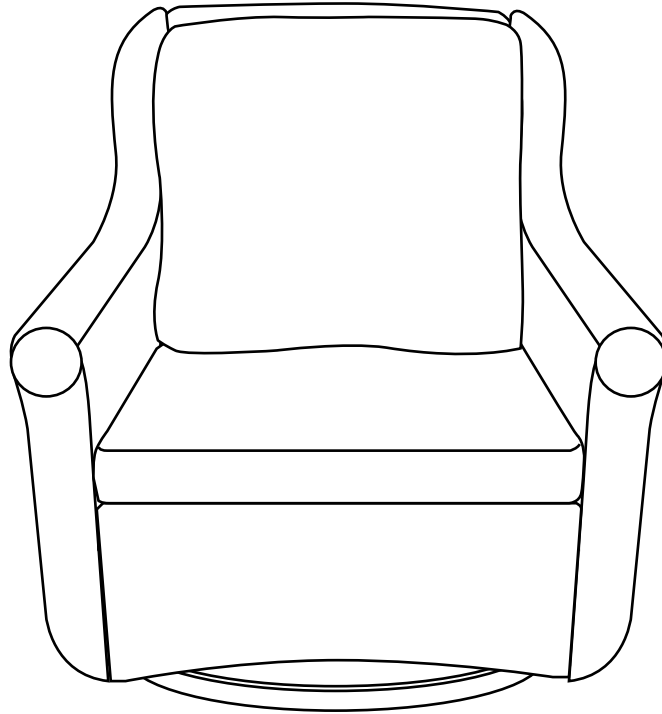

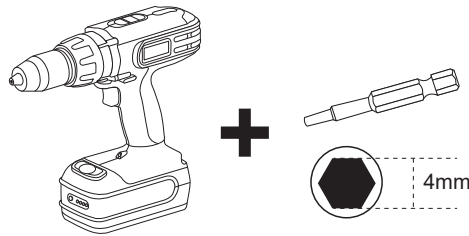





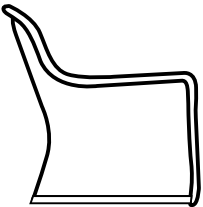

***Don't fully tighten all the bolts till the very end!**

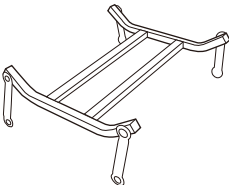
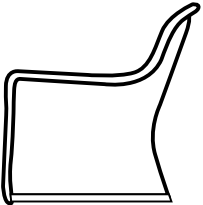
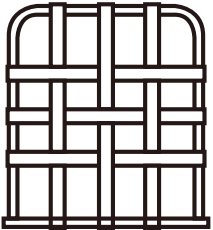
PRE-ASSEMBLY PREPARATION:

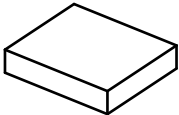
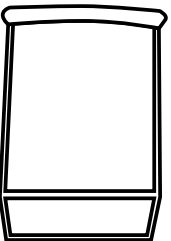
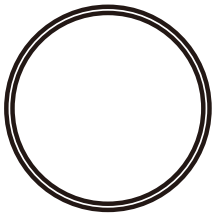
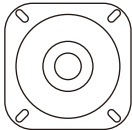
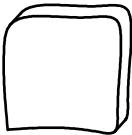

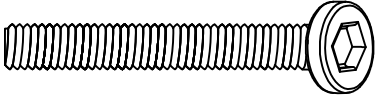
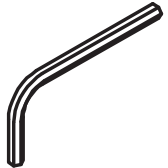
- A cordless drill is recommended for ease of assembly.
- Clear out the space for assembly and lay out all of the parts based on the Parts List, extra room will allow you to easily determine if all the pieces are present.
- Keep small parts and pieces away from children until fully assembled.

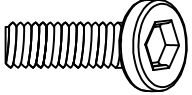
<p>A1</p> <p>Left Arm 1PC</p>		<p>C</p> <p>Front 1PC</p>		<p>F</p> <p>Short support Bar 2 PCS</p>		<p>I</p> <p>U-shape fitting 1PC</p>	
<p>A2</p> <p>Right Arm 1PC</p>		<p>D</p> <p>Seat 1PC</p>		<p>G</p> <p>Support Bar 1PC</p>		<p>O</p> <p>Seat Cushion 1PC</p>	
<p>B</p> <p>Back 1PC</p>		<p>E</p> <p>Base 1PC</p>		<p>H</p> <p>Swivel plate 1PC</p>		<p>P</p> <p>Back Cushion 1PC</p>	

No.	Part/Size	QTY	Image	No.	Part/Size	QTY	Image
J	Bolt (M6*40mm)	4	<p style="text-align: center;">**Actural Scale</p> 	Q	Allen Wrench	1	
K	Bolt (M6*35mm)	22	<p style="text-align: center;">**Actural Scale</p> 	R	Wrench	1	
L	Bolt (M6*15mm)	8					
M	Nut	14					
N	Washer	20					

Step 1: Attach arms A1&A2 to back panel B with 4pcs bolts K and 4pcs washers N ,using Allen wrench Q .Note:Don't fully tighten the bolts.

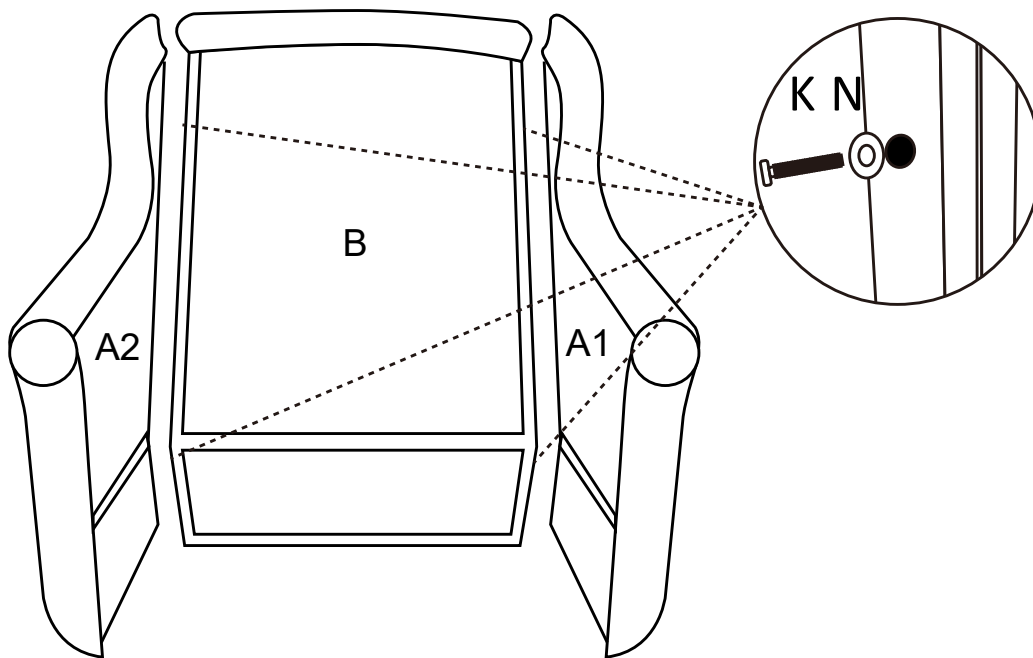

Step 2: Attach front panel B to arms A1&A2 with 4pcs K and 4pcs washer N , using Allen wrench Q .Note:Don't fully tighten the bolts .

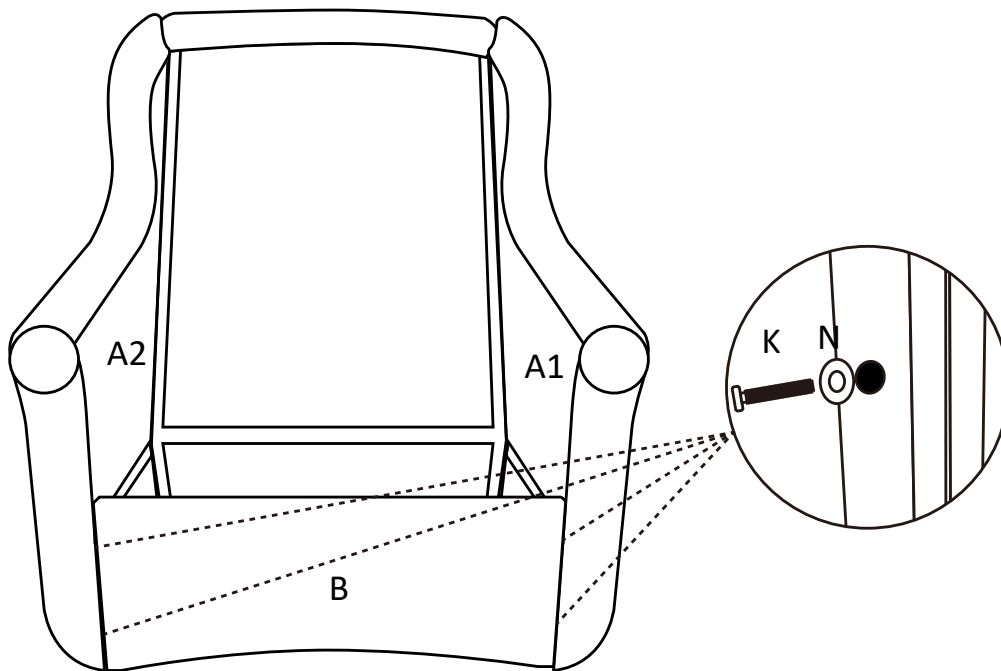

Step 3 : Attach seat panel D to back panel and front panel with 4pcs bolts K and 4pcs washers N ,using Allen wrench Q .Note:Don't fully tighten the bolts .

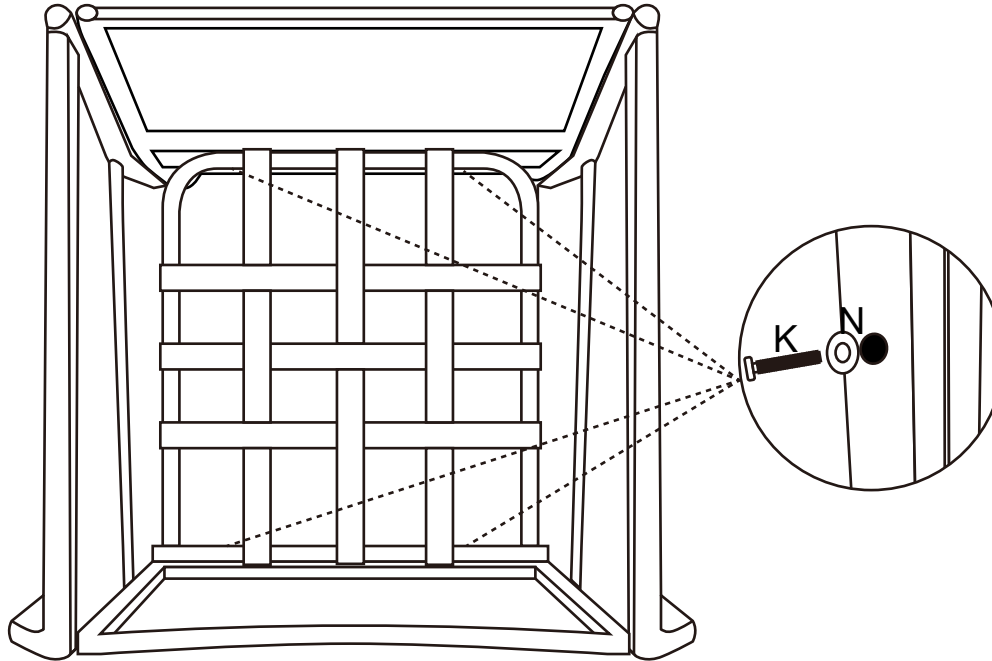

Step 4: Attach 2pcs short support bar F & support G with 2pcs bolts K, 2pcs washers N and 2pcs nuts M, using Allen wrench Q and wrench R. Note: Don't fully tighten all the bolts.

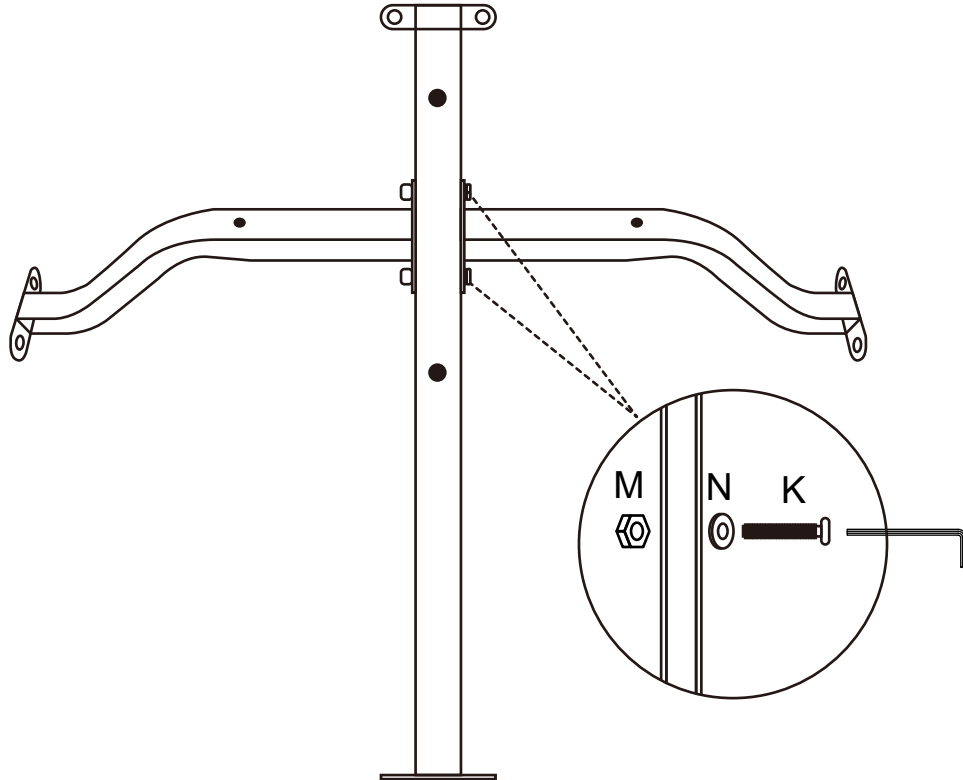

Step 5: Attach support bar to base E with 8pcs bolts L and 8pcs washers N, using Allen wrench Q. Note: Don't fully tighten the bolts.

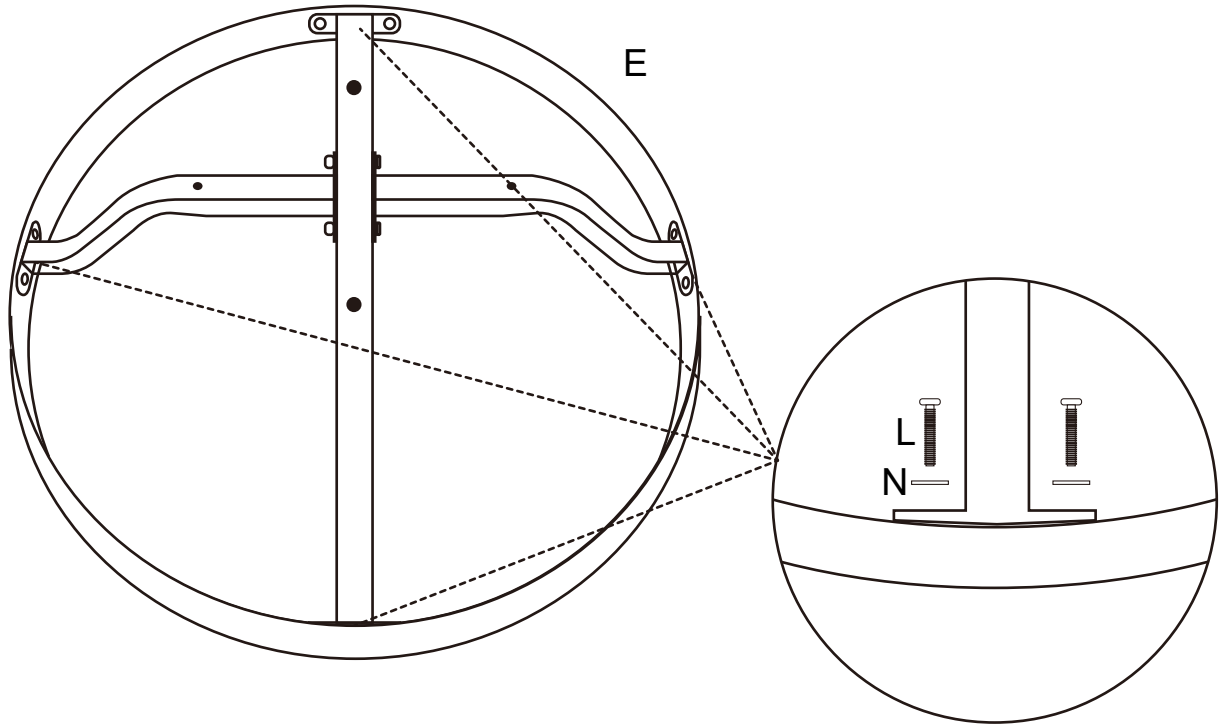

Step 6: Attach swivel plate H to support bar with 4pcs bolts K and 4pcs nuts M, using Allen wrench Q and wrench R .Note:Don't fully tighten all the bolts.

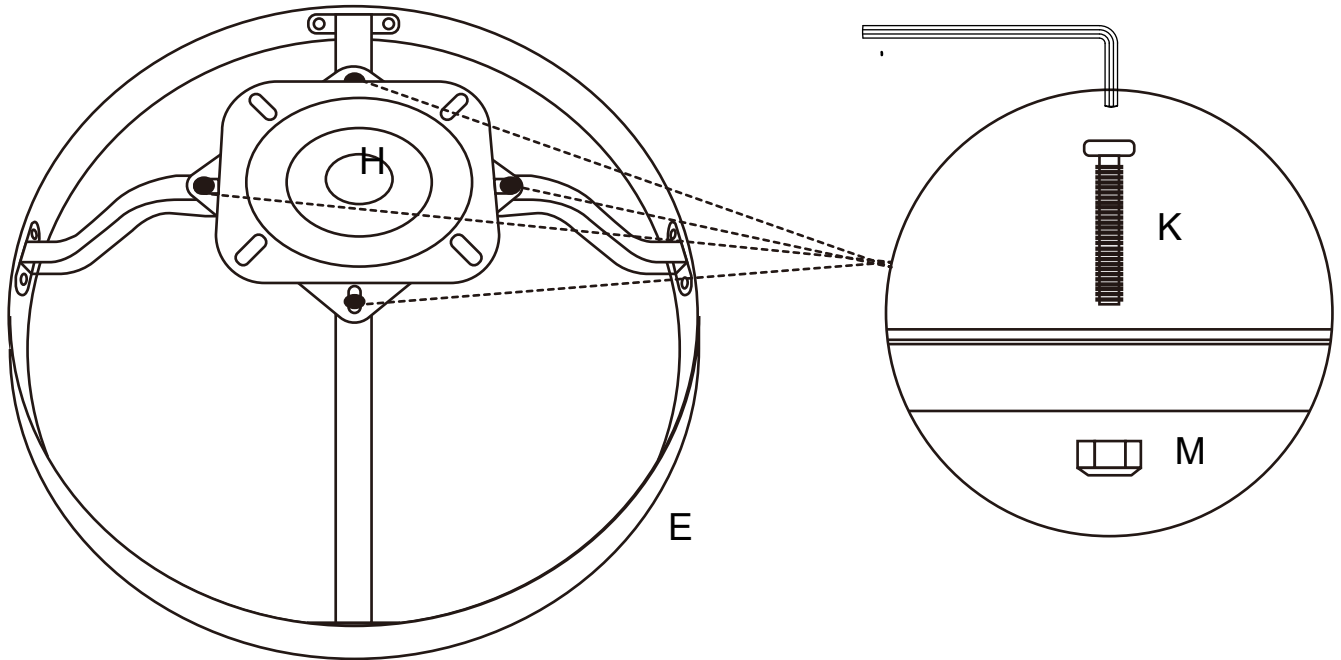

Step 7: Attach u-shape fitting I to swivel plate with 4pcs bolts J and 4pcs nuts M ,using Allen wrench Q and wrench R .Note:Don't fully tighten all the bolts.

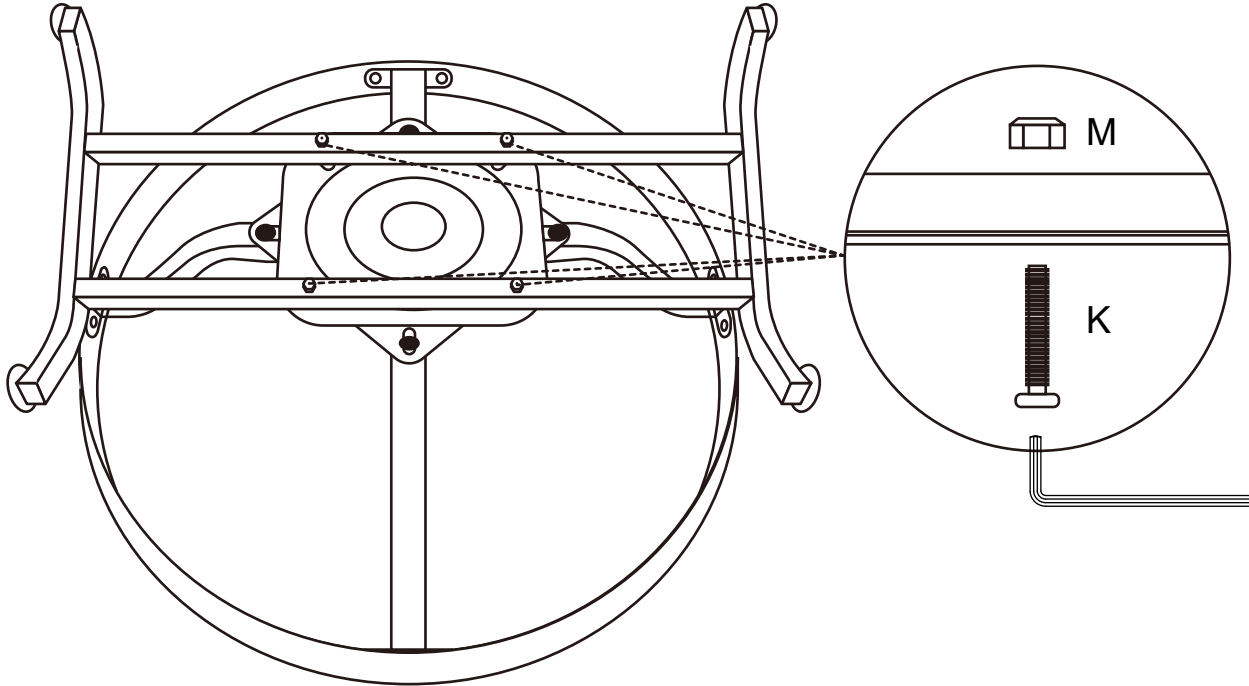

Step 8: Attach swing arm to Arms A1&A2 with 4pcs bolts J and 4pcs nuts M, using Allen wrench Q and wrench R .Note:Please fully tighten all the bolts.

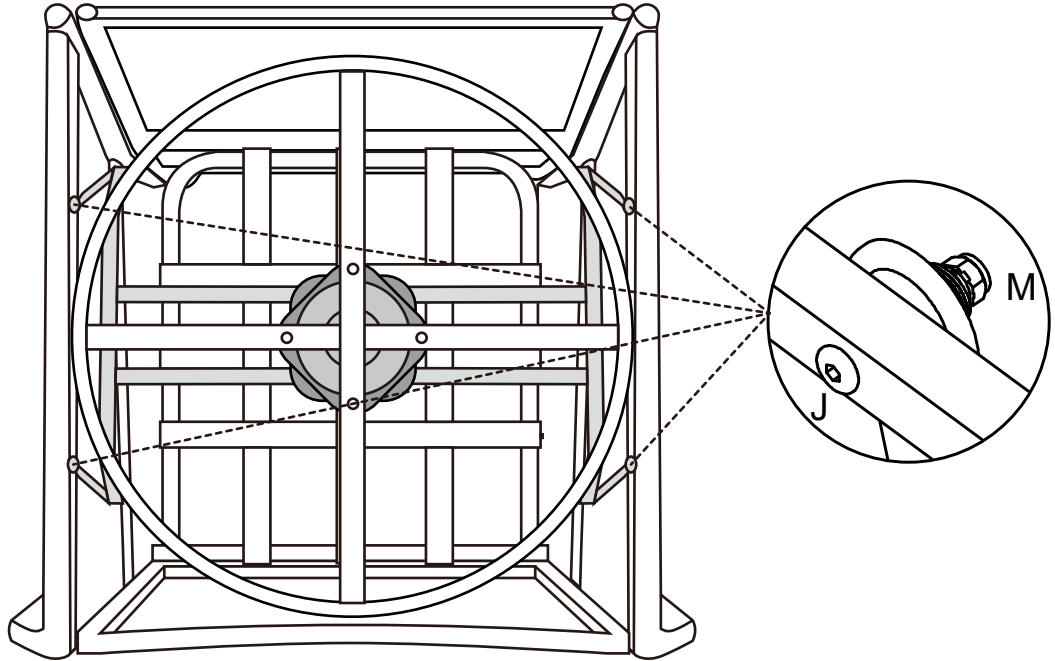

Step 9: Put the seat cushion O and back cushion P onto the seat .Assembly is now complete and the product is ready for use.

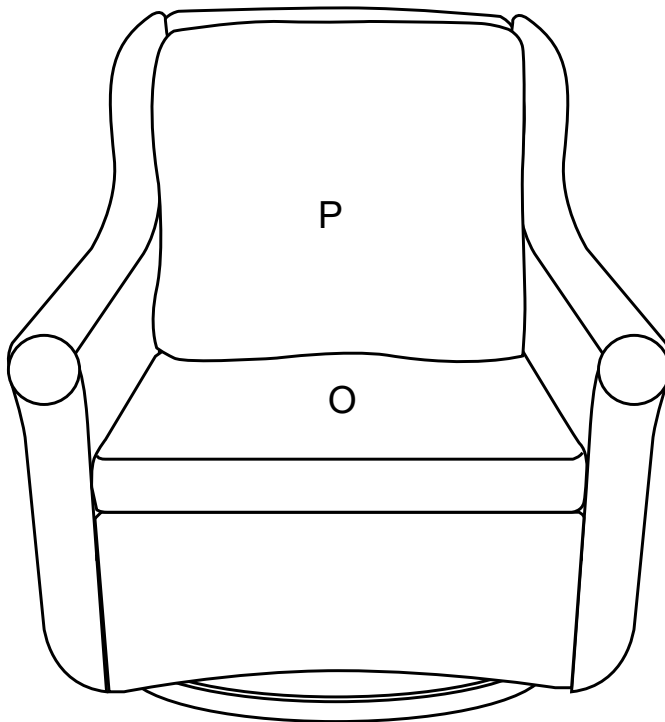

SPECIAL WARNING:

THIS CHAIR IS NOT A TOY. DON'T OVER-SWING THE CHAIR .OVER-SWING THE CHAIR MAYBE MAKE THE CAHIR TIP OVER AND RESULT IN INJURY. DO NOT STAND ON THE CHAIR . Any improper use of this product may result in injury .

