

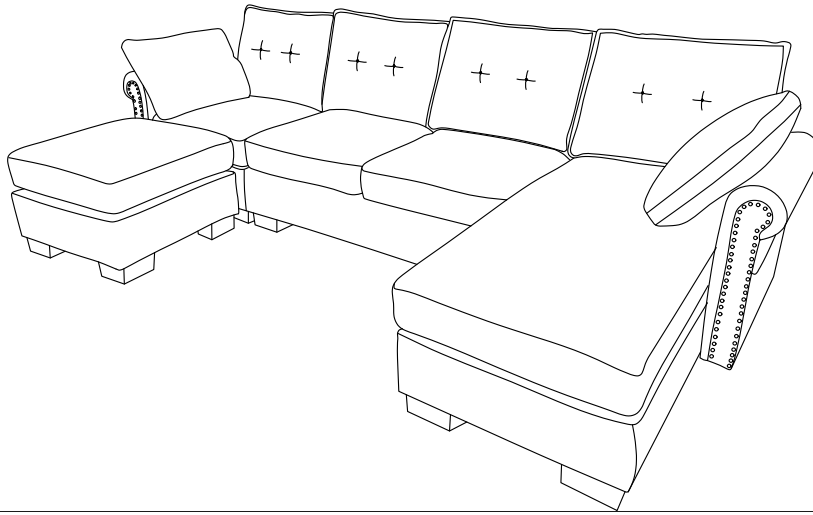

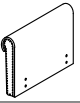







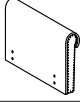
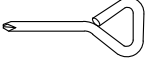
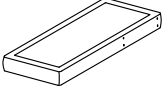

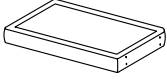

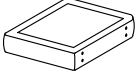

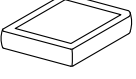

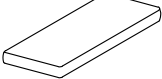

Assembly Instruction

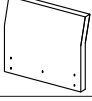

Parts List

Part Number	Picture	Description	QTY	Part Number	Picture	Description	QTY
A		Arm 1	1	M		plastic leg 2 (150*55*75)	10
B		Arm 2	1	N		Cross Wrench	1
C		Base 1	1	O		Screw	38
D		Base 2	1	P		Hex Wrench	1
E		Base 3	1	Q		Screw (8*45)	20
F		Otto	1	R		Screw (8*55)	8
G		Seat cushion 1	4	S		Screw (8*60)	8
H		Seat cushion 2	1	T		Spacer	44
I		Back frame	4	U		Nut	8
J		Back cushion	4	V		Open-endwrench	1
K		pillows	2	W		Magic tape	10
L		plastic leg (150*150*55*75)	6				

STEP 1:

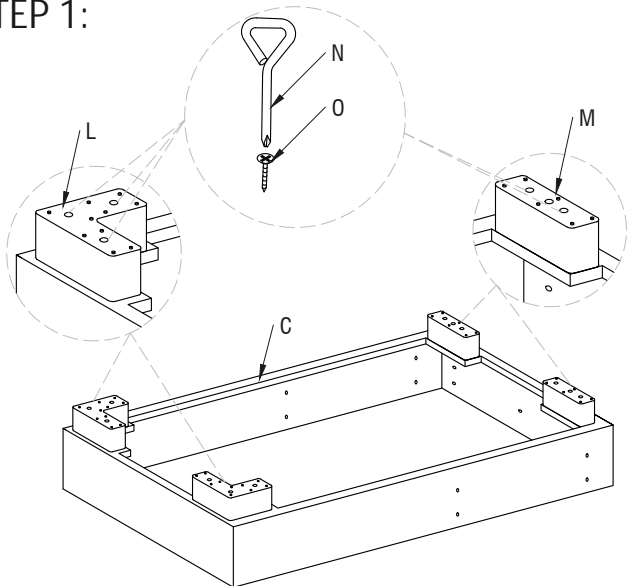

leg L/M through N/O fixed on base C

STEP 2:

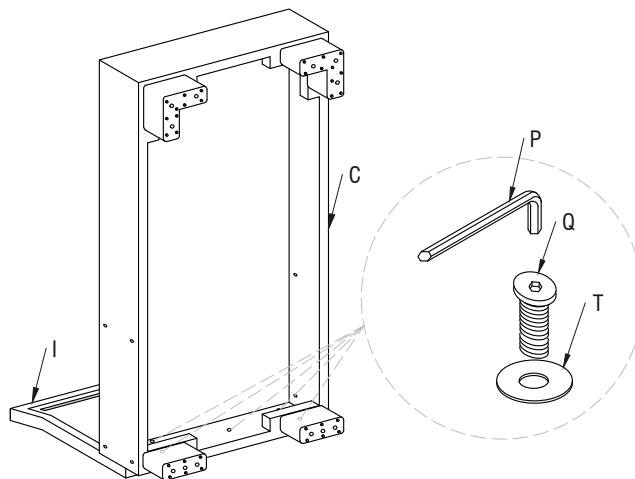

Through P/Q/T fixed on base C and back frame I

STEP 3:

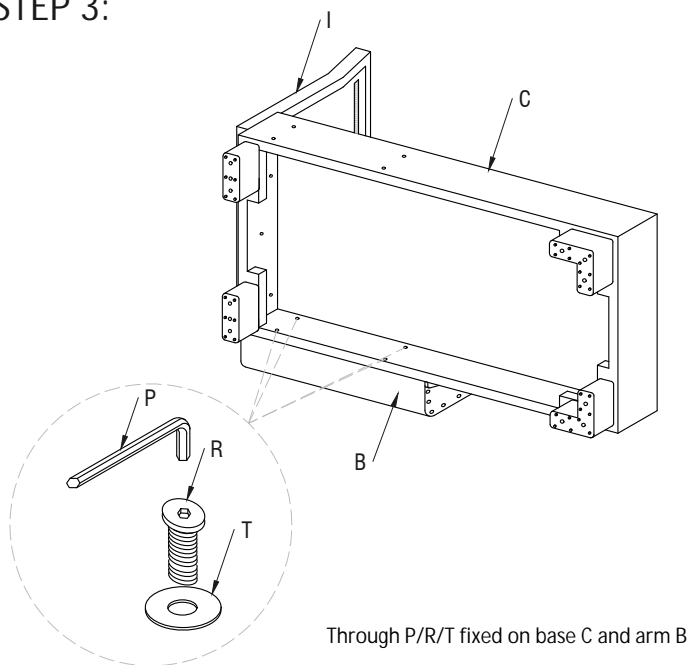

Through P/R/T fixed on base C and arm B

STEP 4:

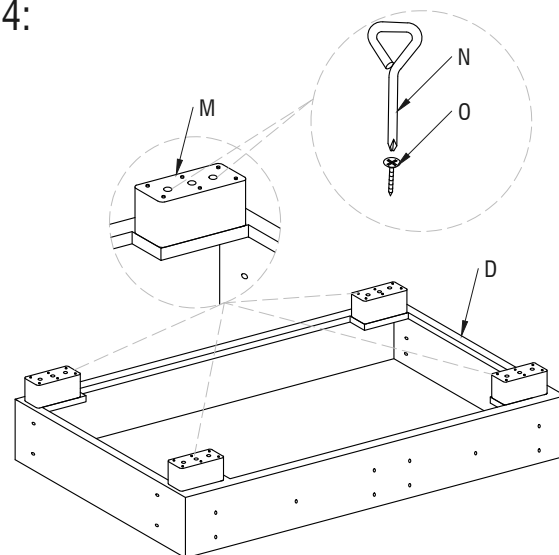

leg M through N/O fixed on base D

STEP 5:

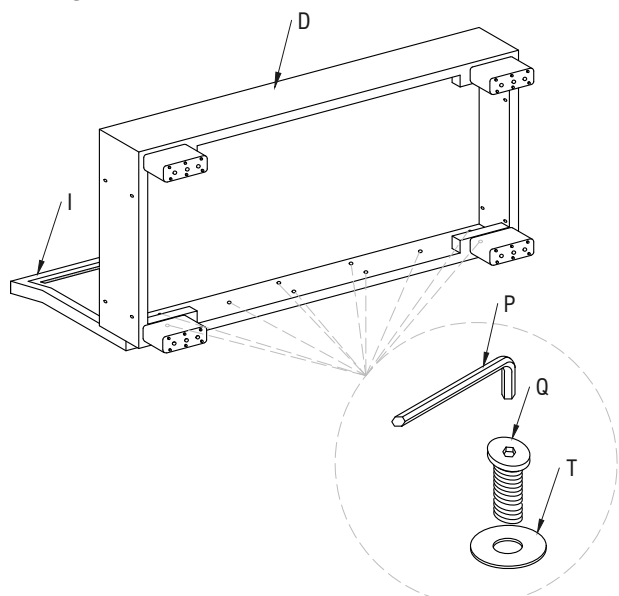

Through P/R/T fixed on base D and back I

STEP 6:

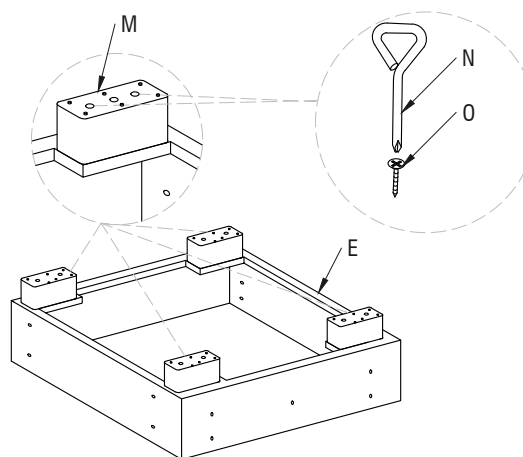

Plastic leg M through N/O fixed on base E

STEP 7:

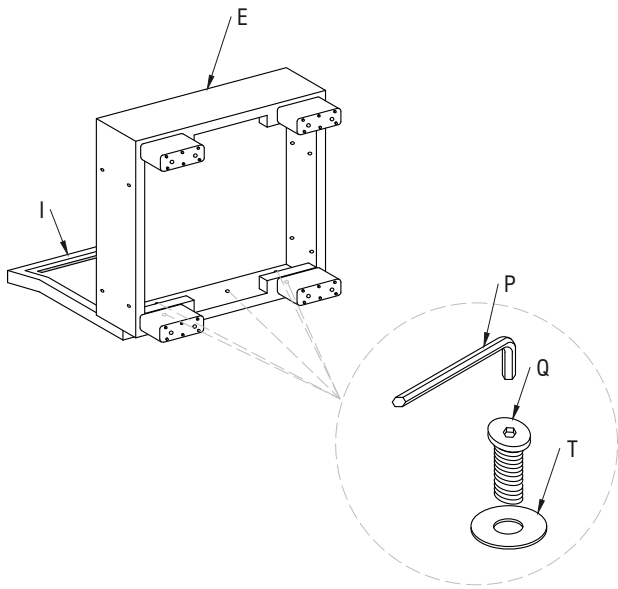

Through P/R/T fixed on base C and arm B

STEP 8:

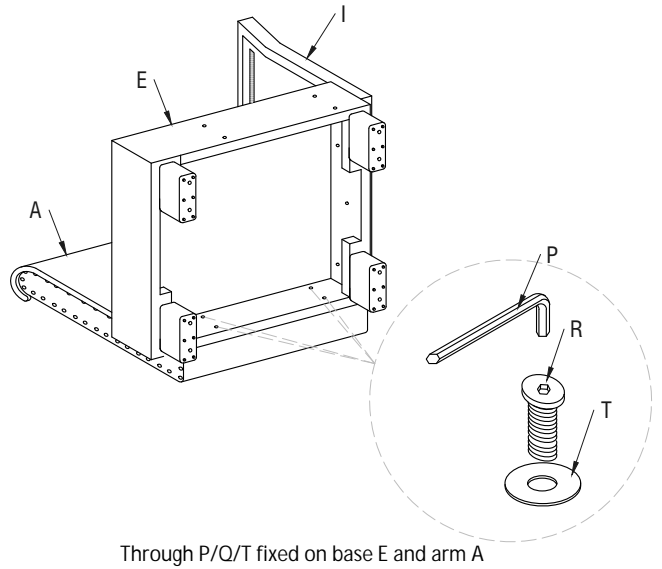

Through P/Q/T fixed on base E and arm A

STEP 9:

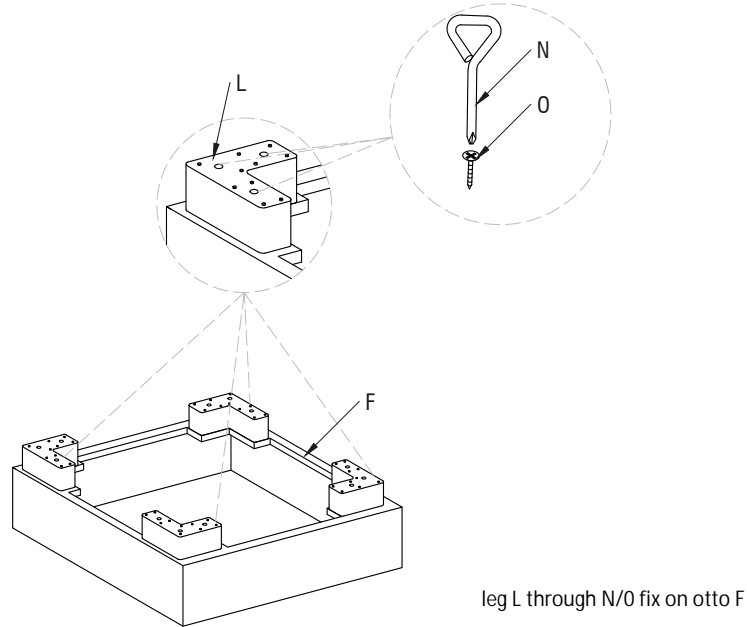

leg L through N/O fix on otto F

STEP 10:

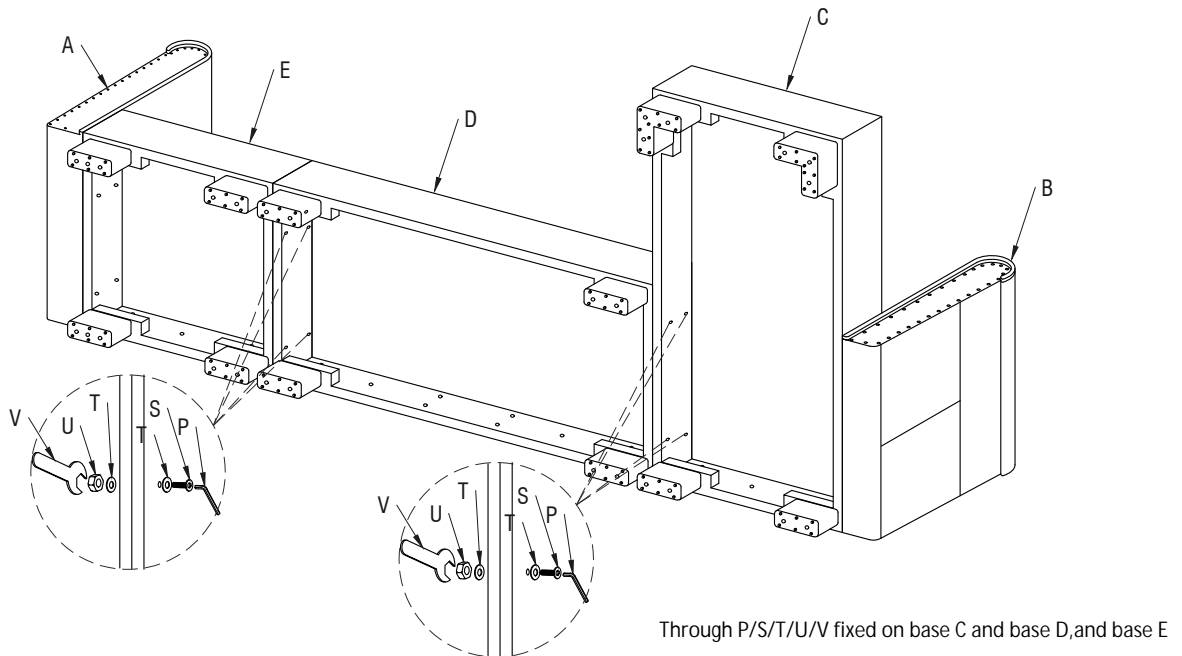

Through P/S/T/U/V fixed on base C and base D, and base E

STEP 11:

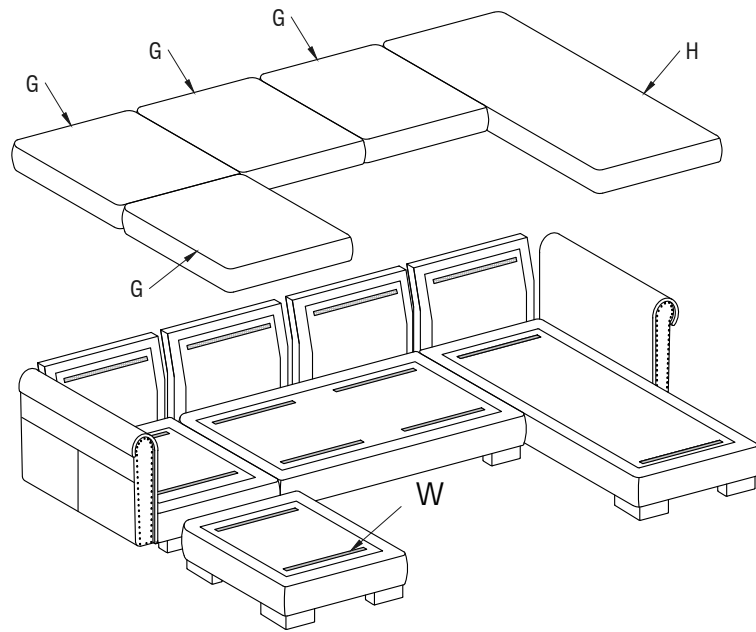

magic tape W stuck on the bottom of seat , then put the cushion G and H on it

STEP 12:

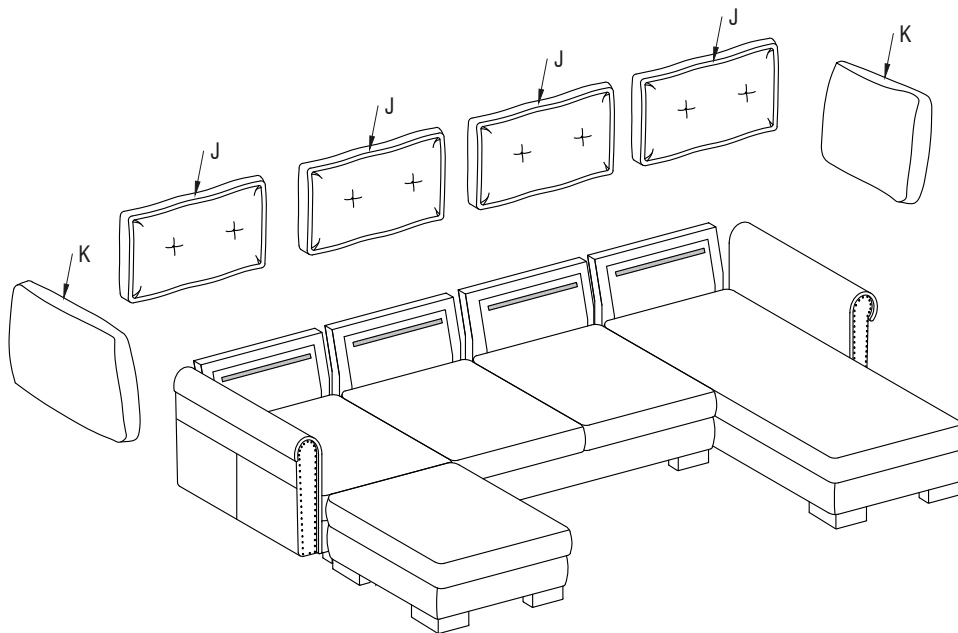

Put J and K on it

STEP 11:

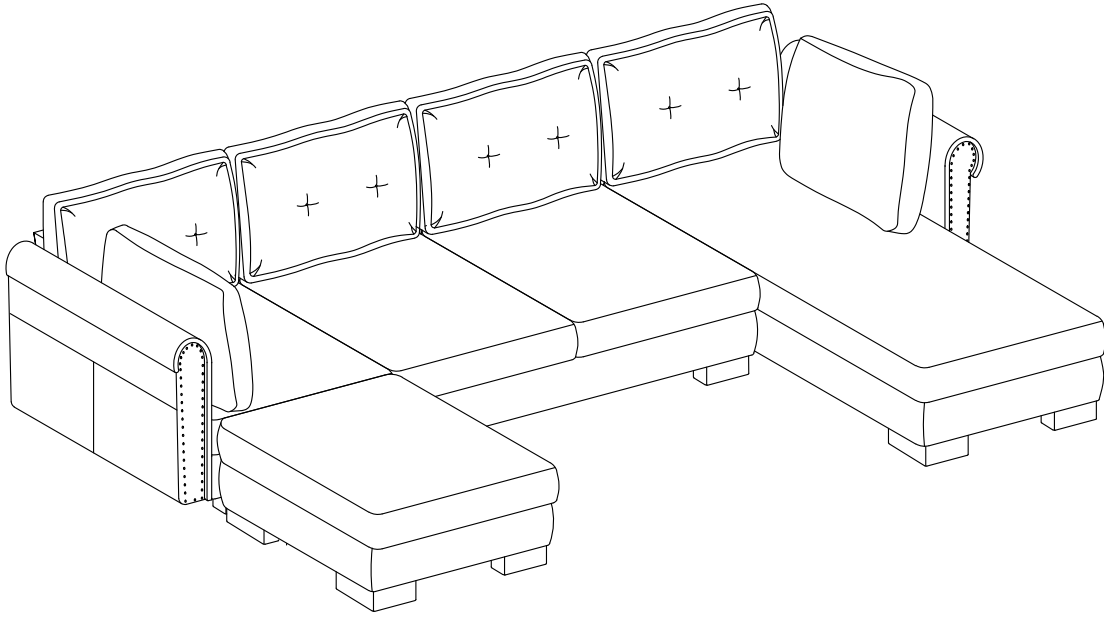

Reversible 1

STEP 13:

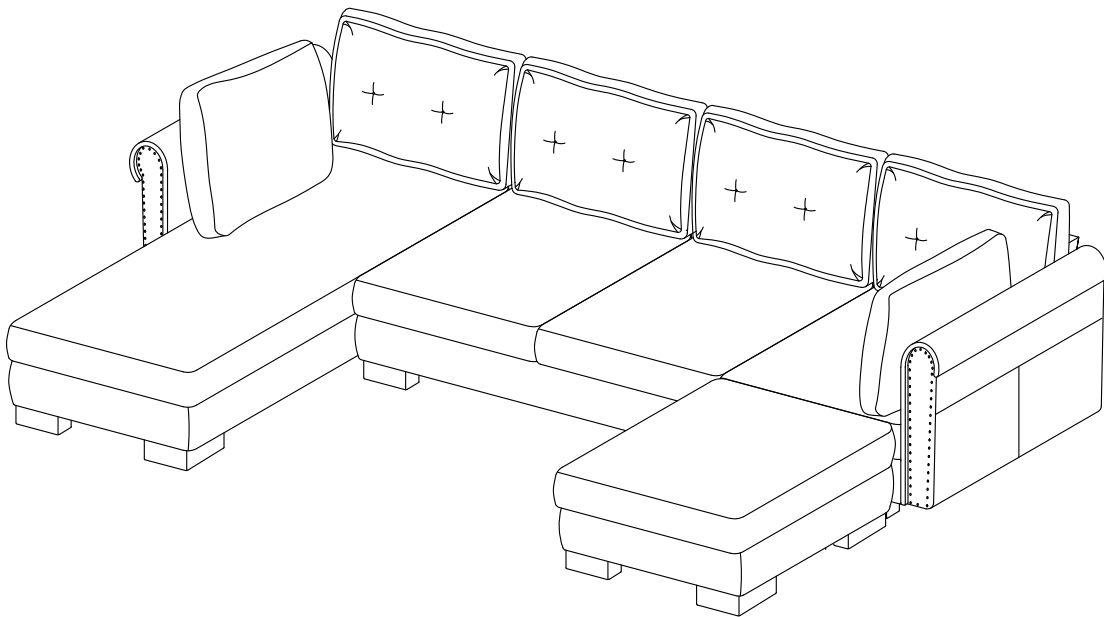

Reversible 2