

Assembly Instructions

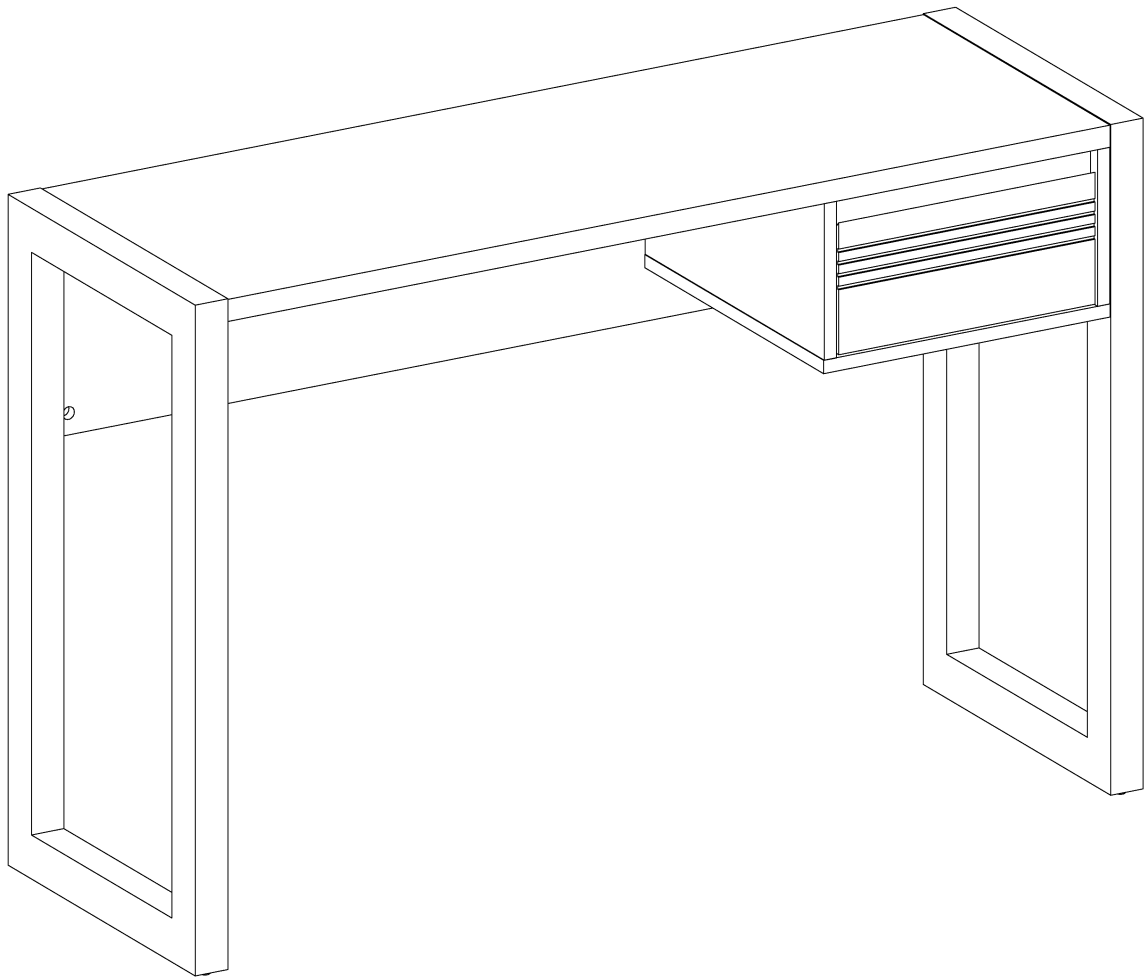

General Assembly Guidelines

- I. Ensure that all parts and hardware are available before beginning assembly.
- II. Follow each step carefully to ensure the proper assembly of this product.
- III. Two people are recommended for ease in the assembly of this product.
- IV. The three main types of hardware used to assemble this product are: wood dowels, screws and bolts.
- V. The provided glue is to secure wood dowels in place. When first inserting dowels, locate the appropriate hole for the dowel, place a small amount of glue in the hole and insert the dowel. Wipe away excess glue immediately.

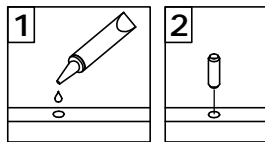

In future assembly steps when dowels are necessary to attach assembly parts together, place a small amount of glue on the end of the dowel before attaching parts together. Wipe away excess glue immediately.

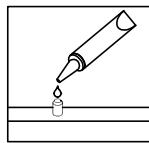

- VI. A Phillips head screwdriver is required for the assembly of this product .

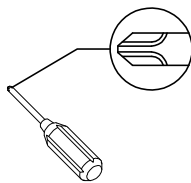

- VII. Power tools should not be used to assemble this product.

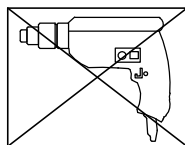





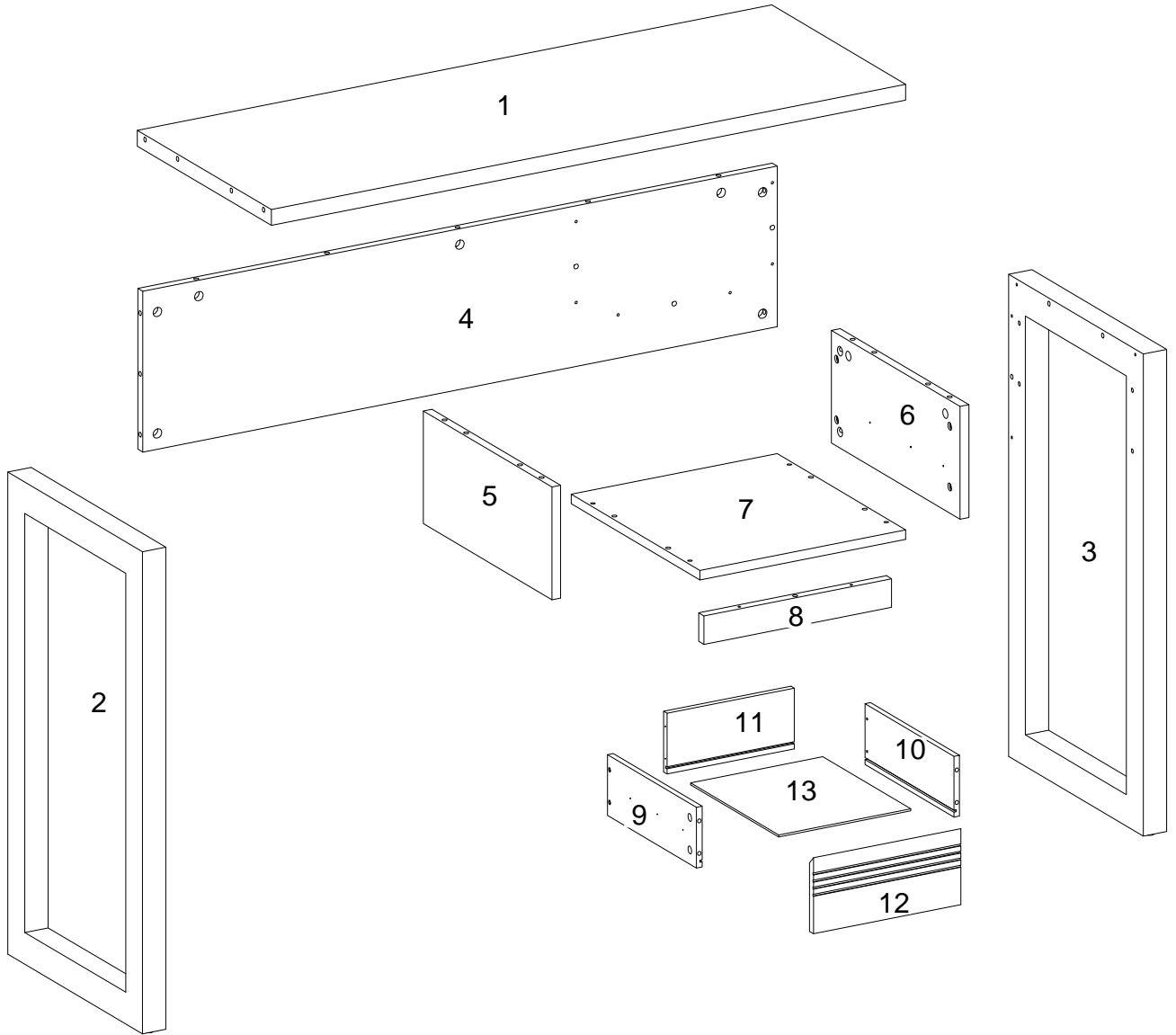





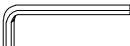

- VIII. Drill may be needed for securing product to wall.

Parts List

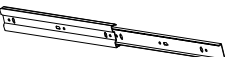

Hardware List

A		Ø8x30mm	Wooden dowel	20 pcs
B		Ø6x35mm	Cam bolt	25 pcs
C		Ø15x11mm	Cam lock	21 pcs
D		Ø15x9.5mm	Cam lock	4 pcs
E		Ø30mm	Sticker	7/18 pcs
F		Ø6x50mm	Screw	4 pcs
G		4mm	Hex Key	1 pc
H		Ø4x50mm	Screw	2 pcs
J		Ø4x32mm	Screw	4 pcs
K		Ø3x12mm	Screw	12 pcs
L		Ø6x25mm	Bolt	4 pcs
M			Glue tube	1 pcs
N			Drawer slider	1 sets

* Note: This piece comes preassembled for shipping purposes and must be disassembled to complete the desk assembly.

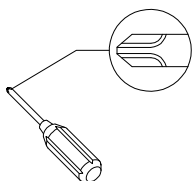

**Philips head screwdriver required for assembly
(not included)**

*The hardware quantities listed above are required for proper assembly.
Some extra hardware may also have been included.*

Step 1

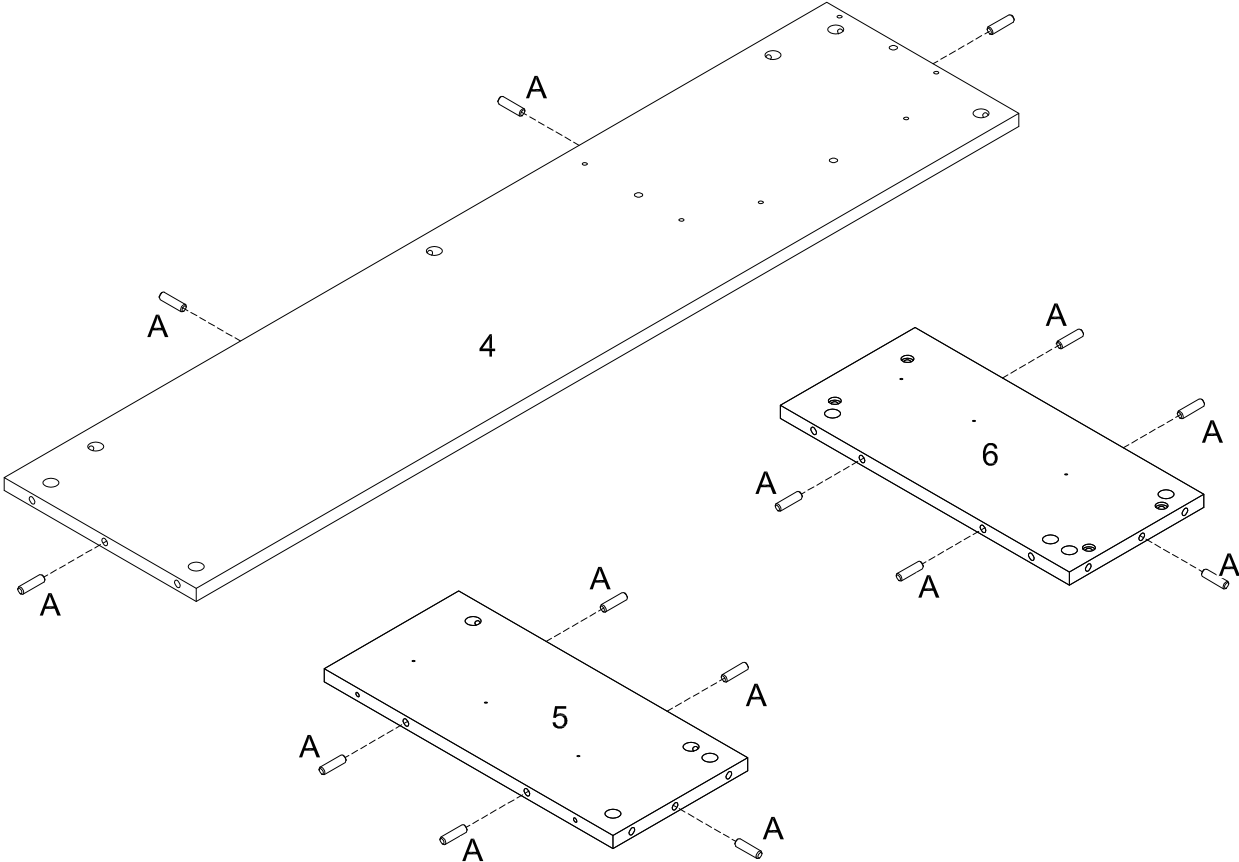

Insert wooden dowel (A) into parts (4,5,6) as per diagram.

Step 2

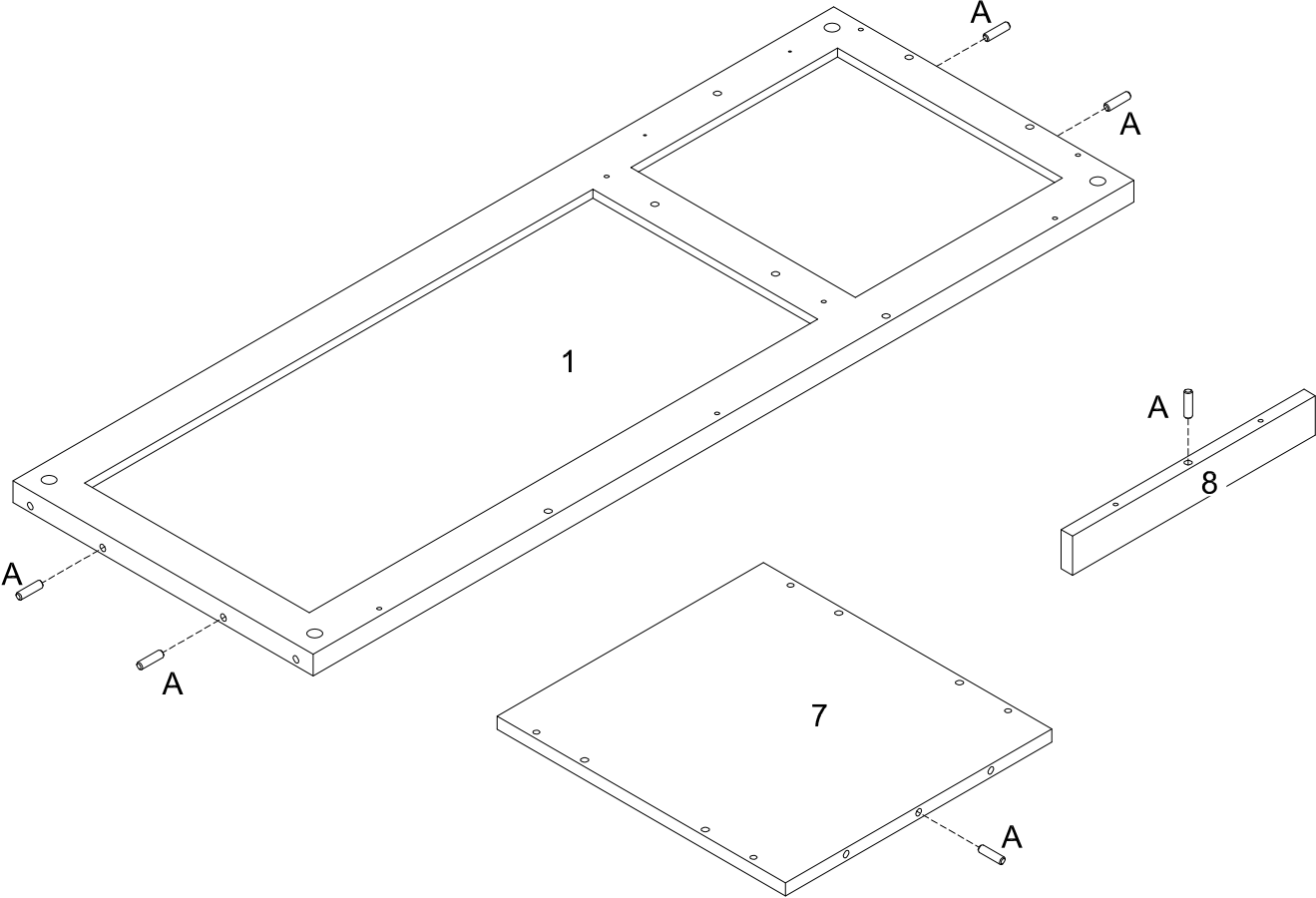

Insert wooden dowel (A) into parts (1,7,8) as per diagram.

Step 3

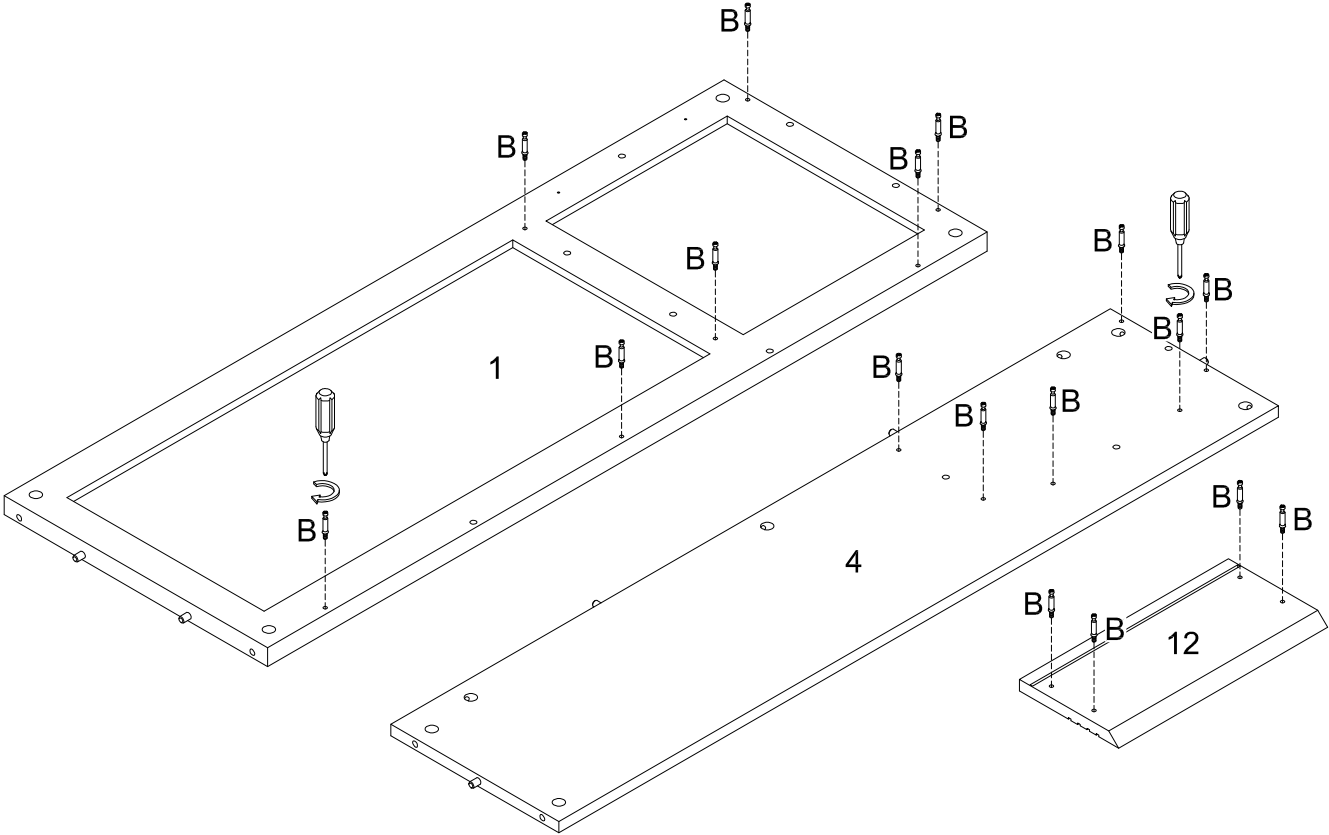

Secure cam bolt (B) into parts (1,4,12) with Philips head screwdriver as per diagram.

Step 4

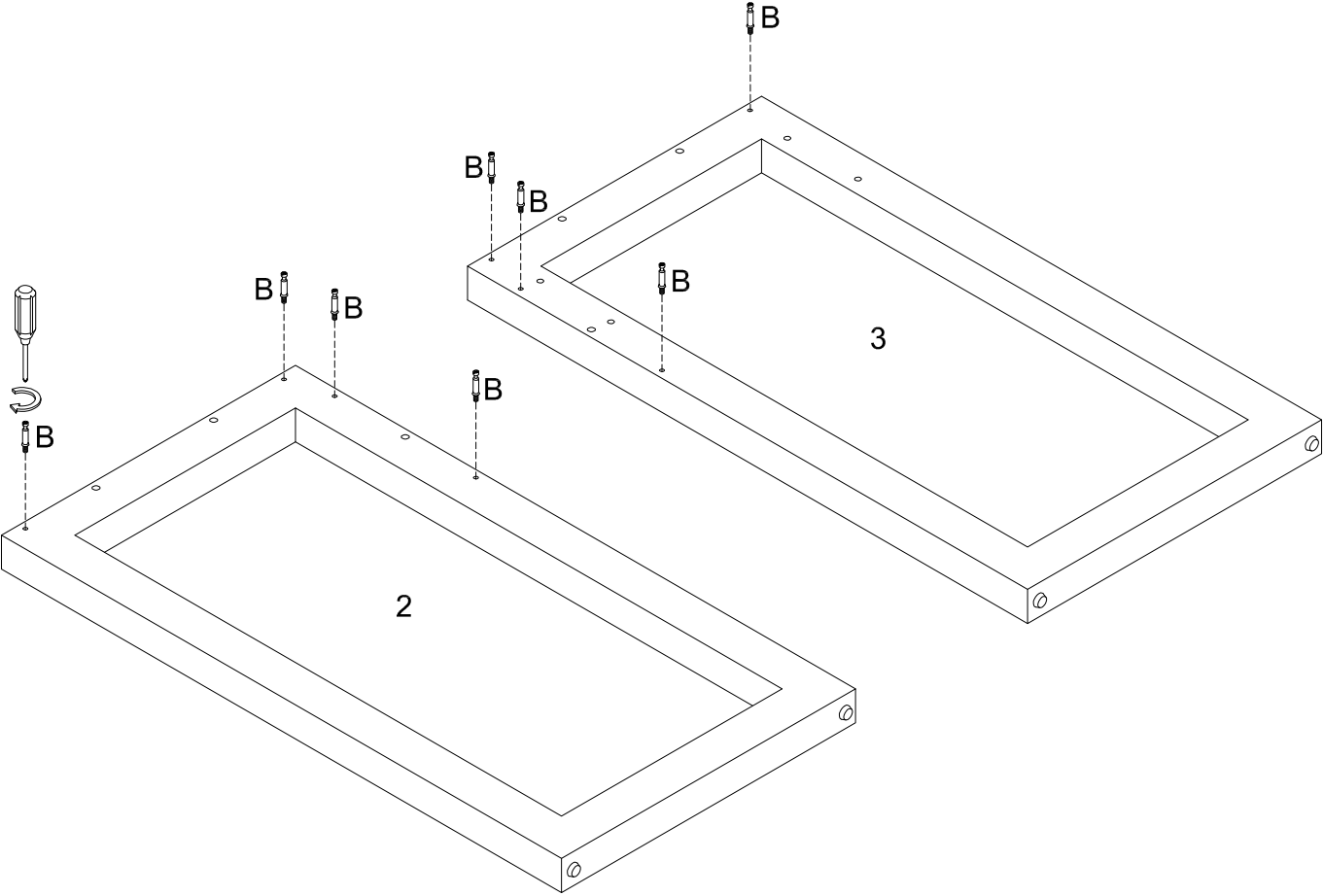

Secure cam bolt (B) into parts (2,3) with Philips head screwdriver as per diagram.

Step 5

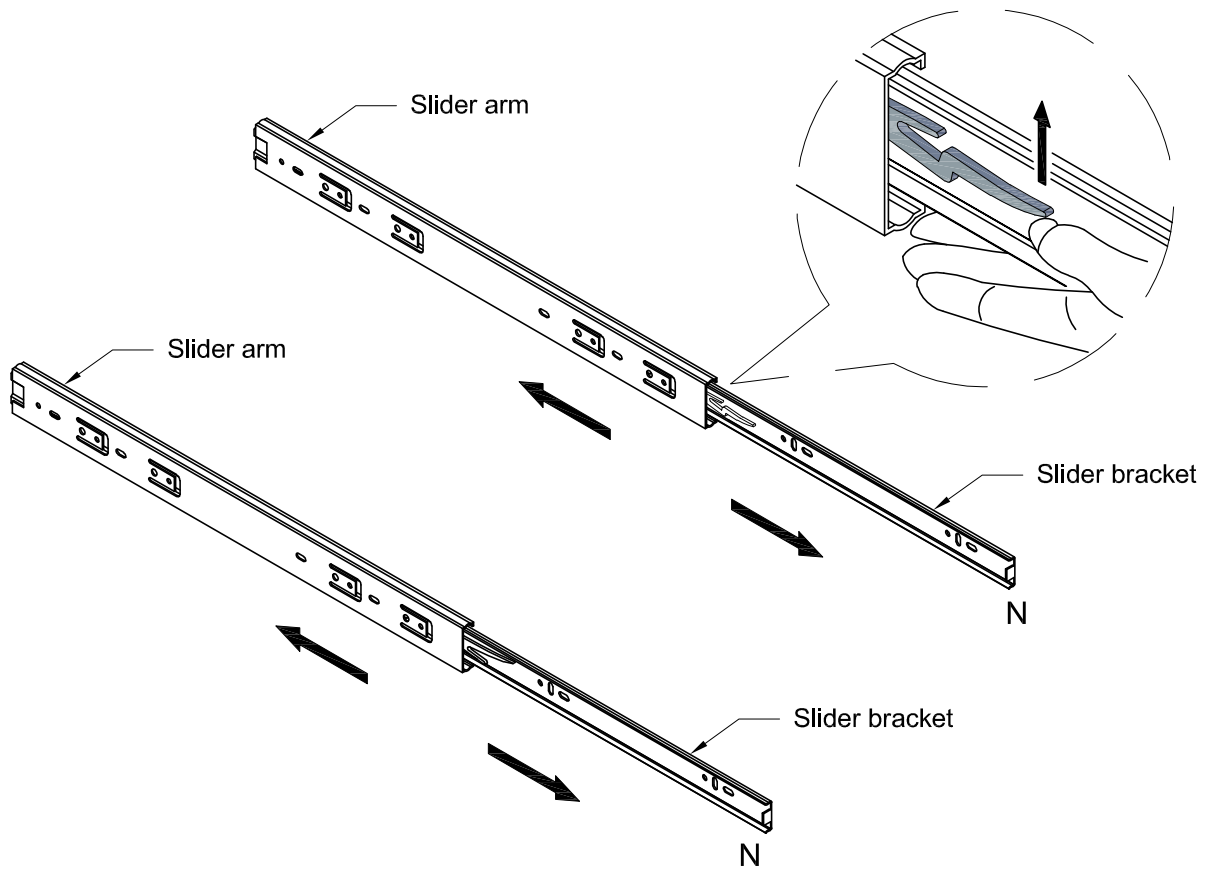

Pick up the slider arm (N) and separate the slide Runner for the following Steps. Extend the Slide .Runner all the way forward,press the plastic release lever of the slider arm up and pull the Slide Runner Complete out .

Step 6

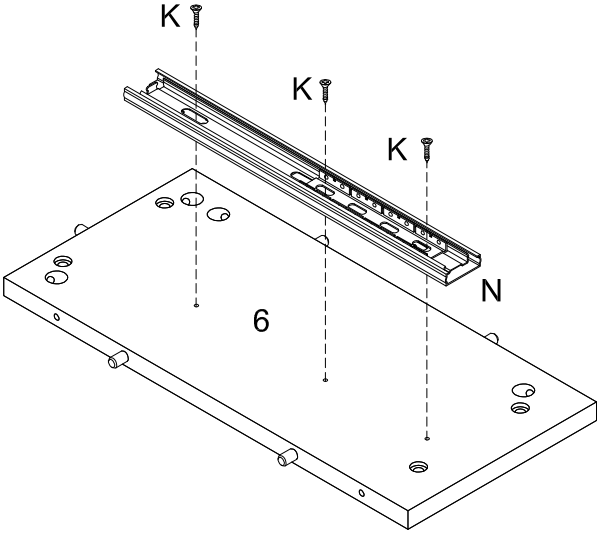
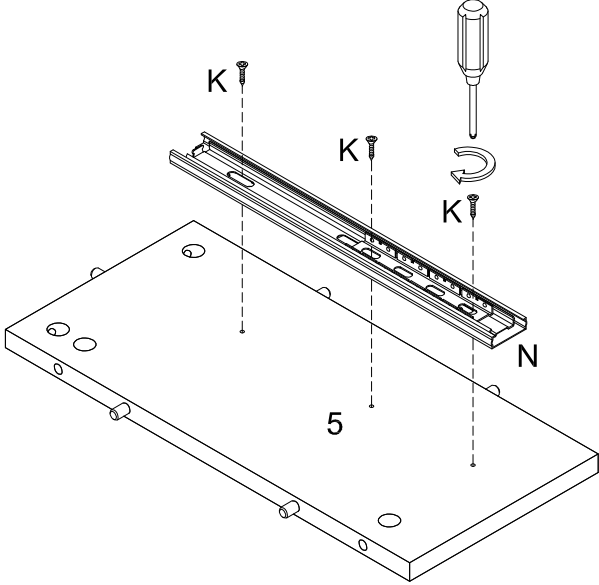
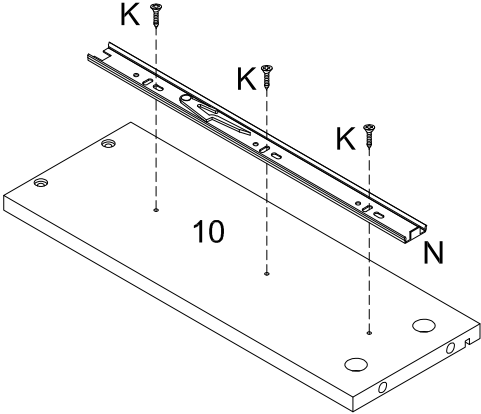
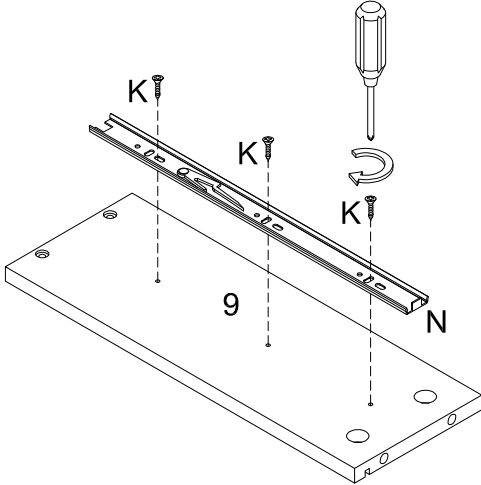

Using screw (K) attach slider (N) to parts (5,6,9,10) with Philips head screwdriver as per diagram.

Step 7

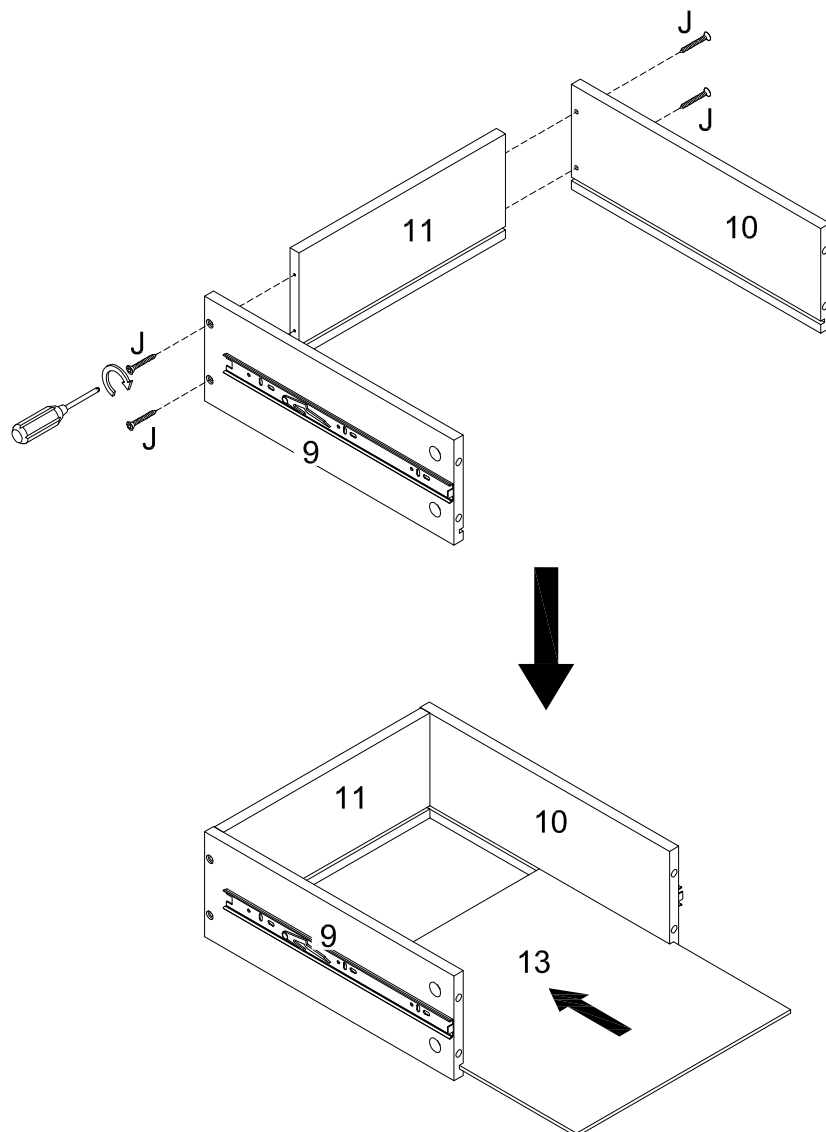

Using screw (J) attach parts (9,10) to part (11) with Philips head screwdriver as per diagram. then put part (13) as per diagram.

Step 8

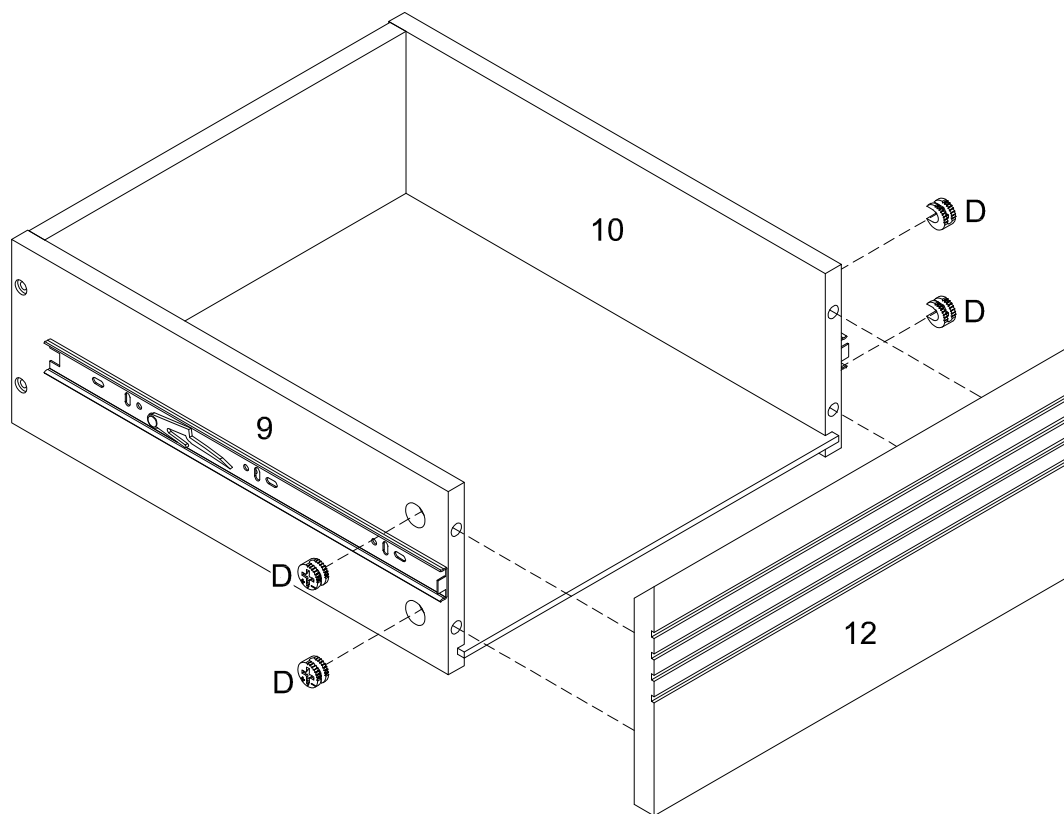
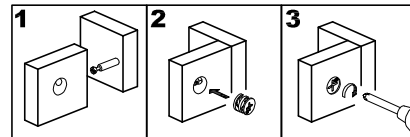

Using cam lock(D) secure part (12) to parts (9,10) with Philips head screwdriver as per diagram.

Step 9

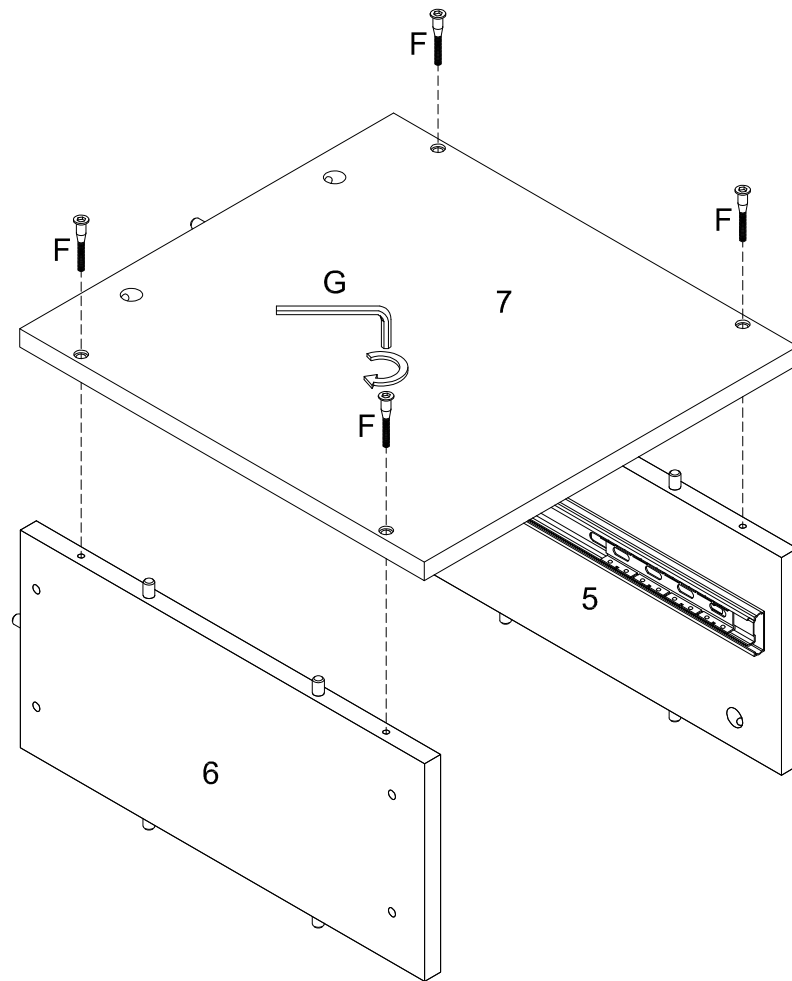

Using screw (F) attach part (7) to parts (5,6) with hex key (G) as per diagram.

Step 10

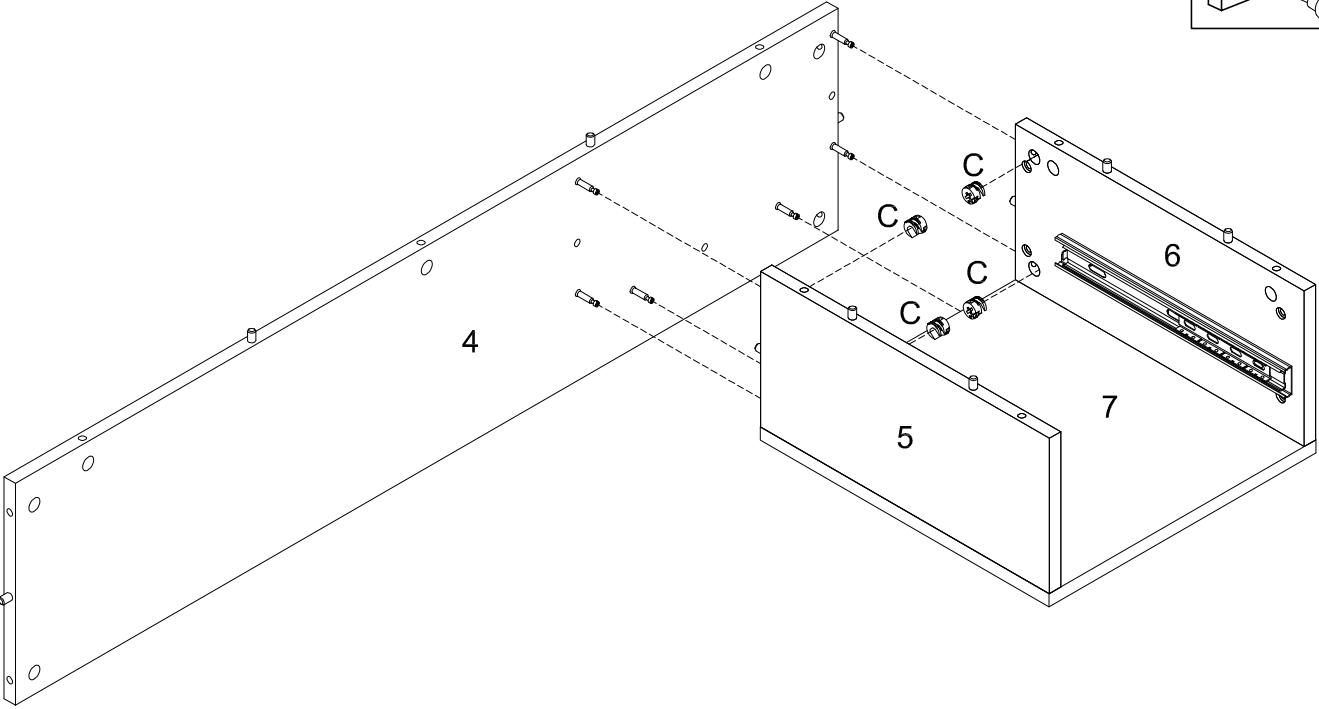
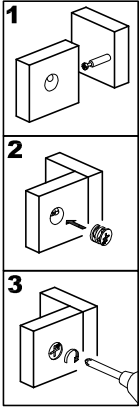

Using cam lock(C) secure part (4) to parts (5,6,7) with Philips head screwdriver as per diagram.

Step 11

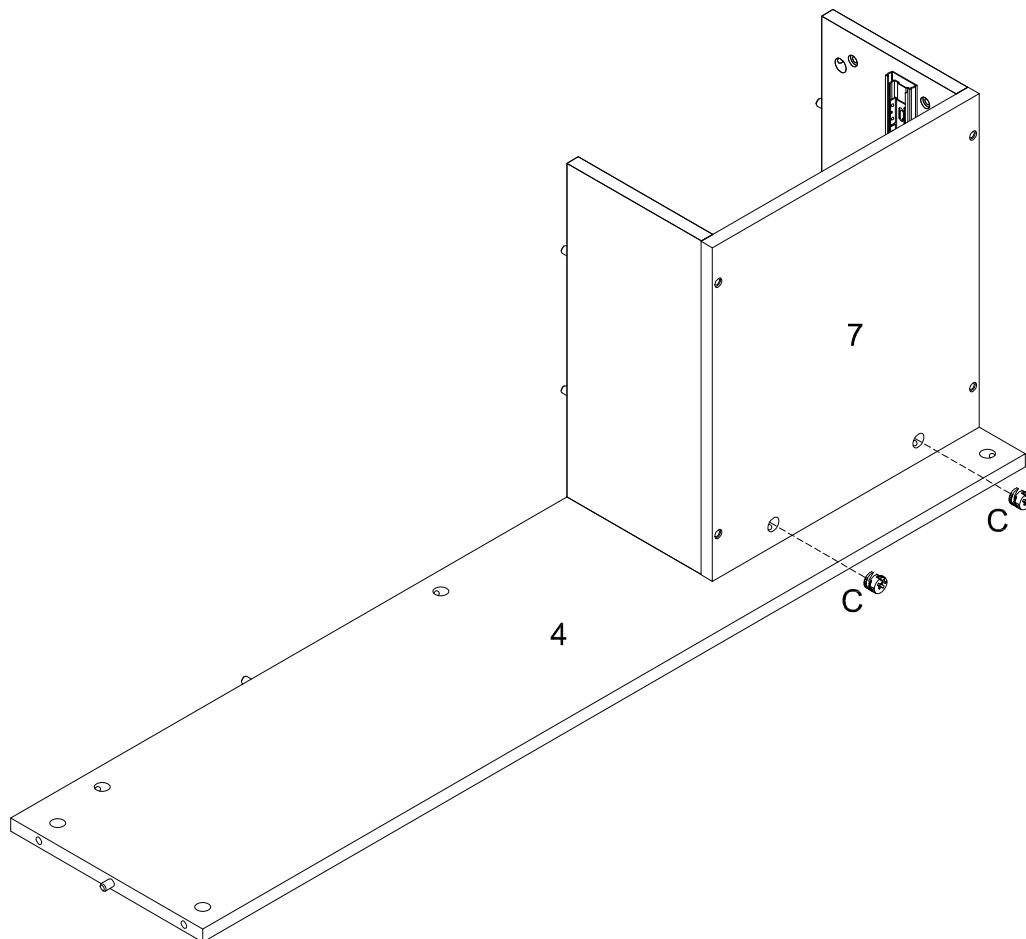
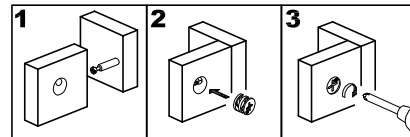

Using cam lock(C) secure part (7) to part (4) with Philips head screwdriver as per diagram.

Step 12

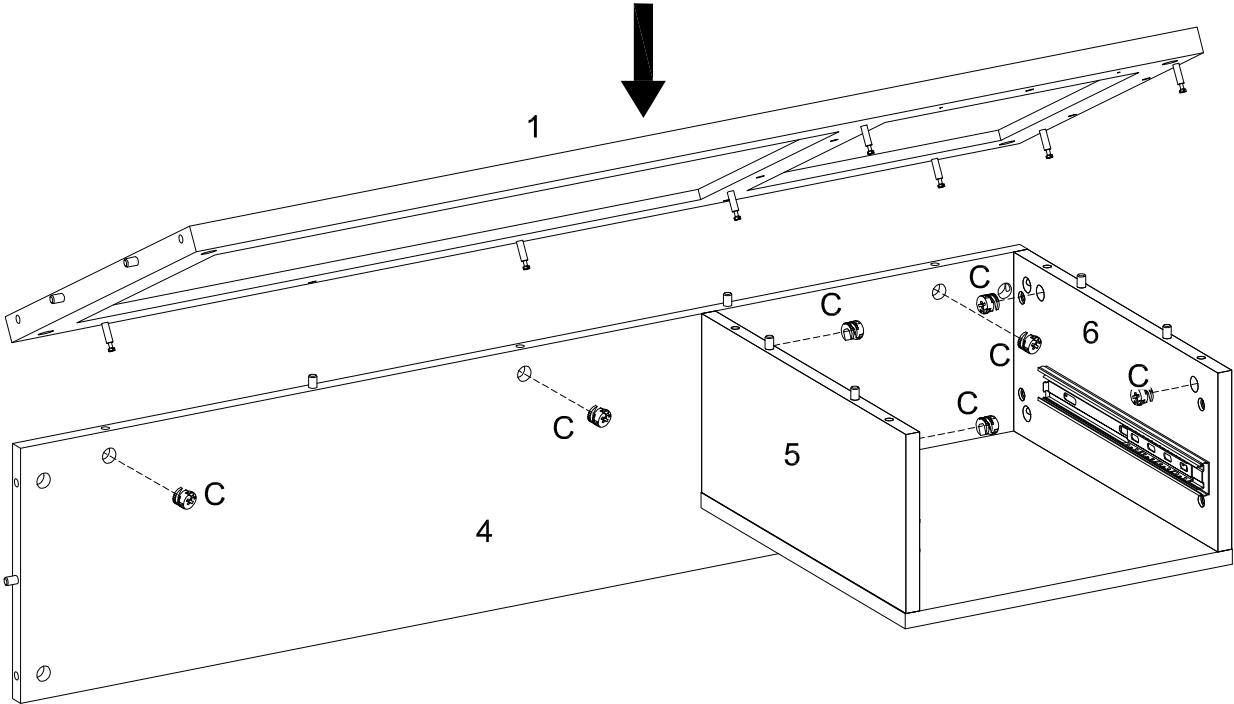
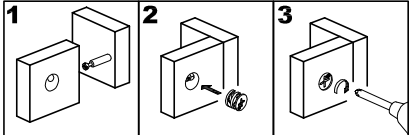

Using cam lock(C) secure part (1) to parts (4,5,6) with Philips head screwdriver as per diagram.

Step 13

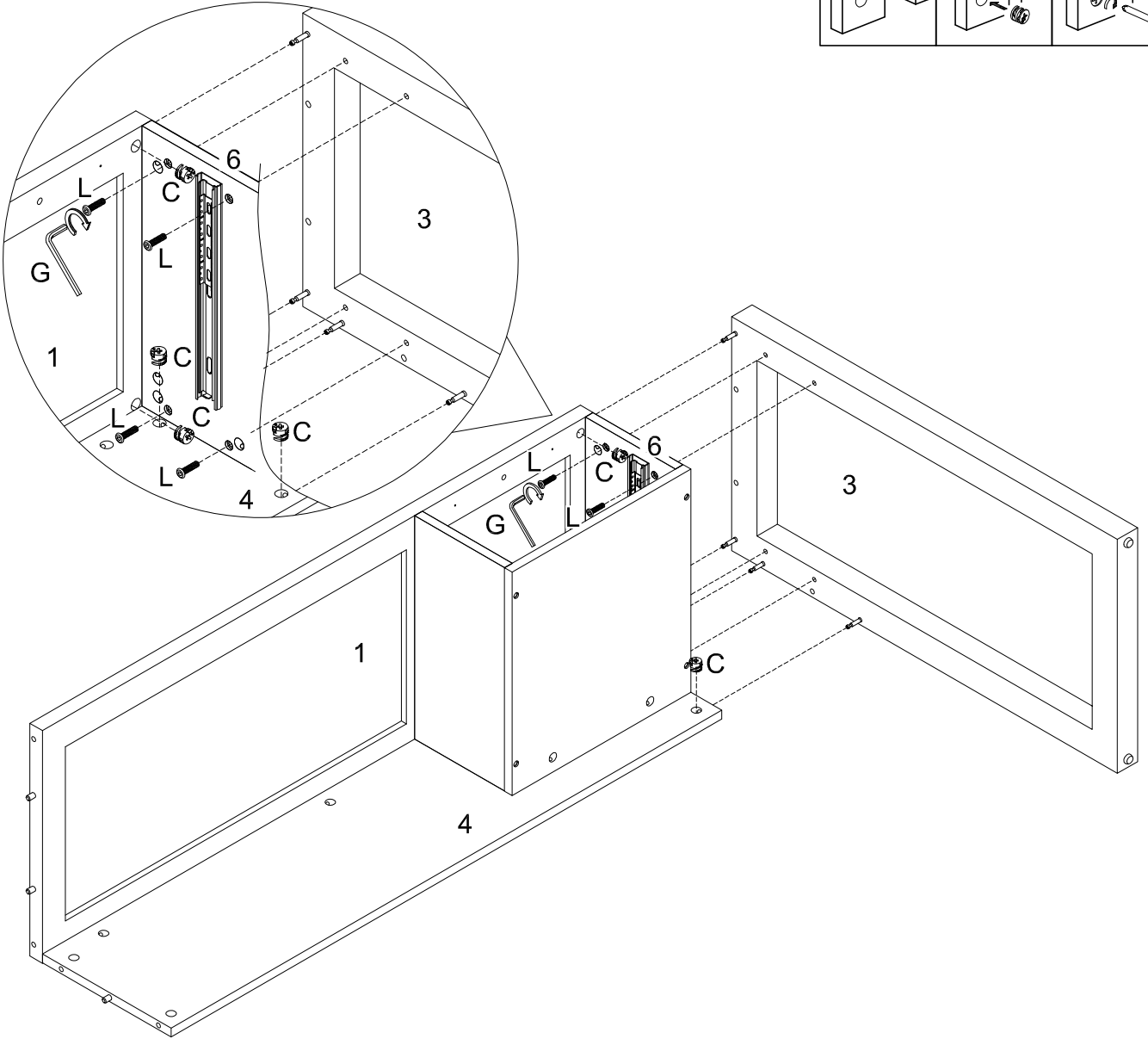
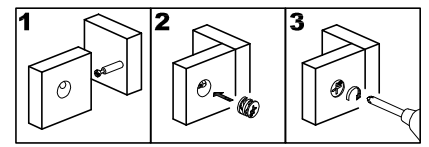

Using cam lock(C) secure part (3) to parts (1,4) with Philips head screwdriver, then using bolt (L) attach part (6) to part (3) with Hex key (G) as per diagram.

Step 14

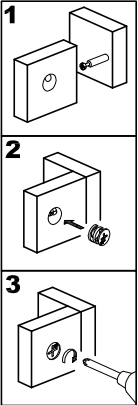
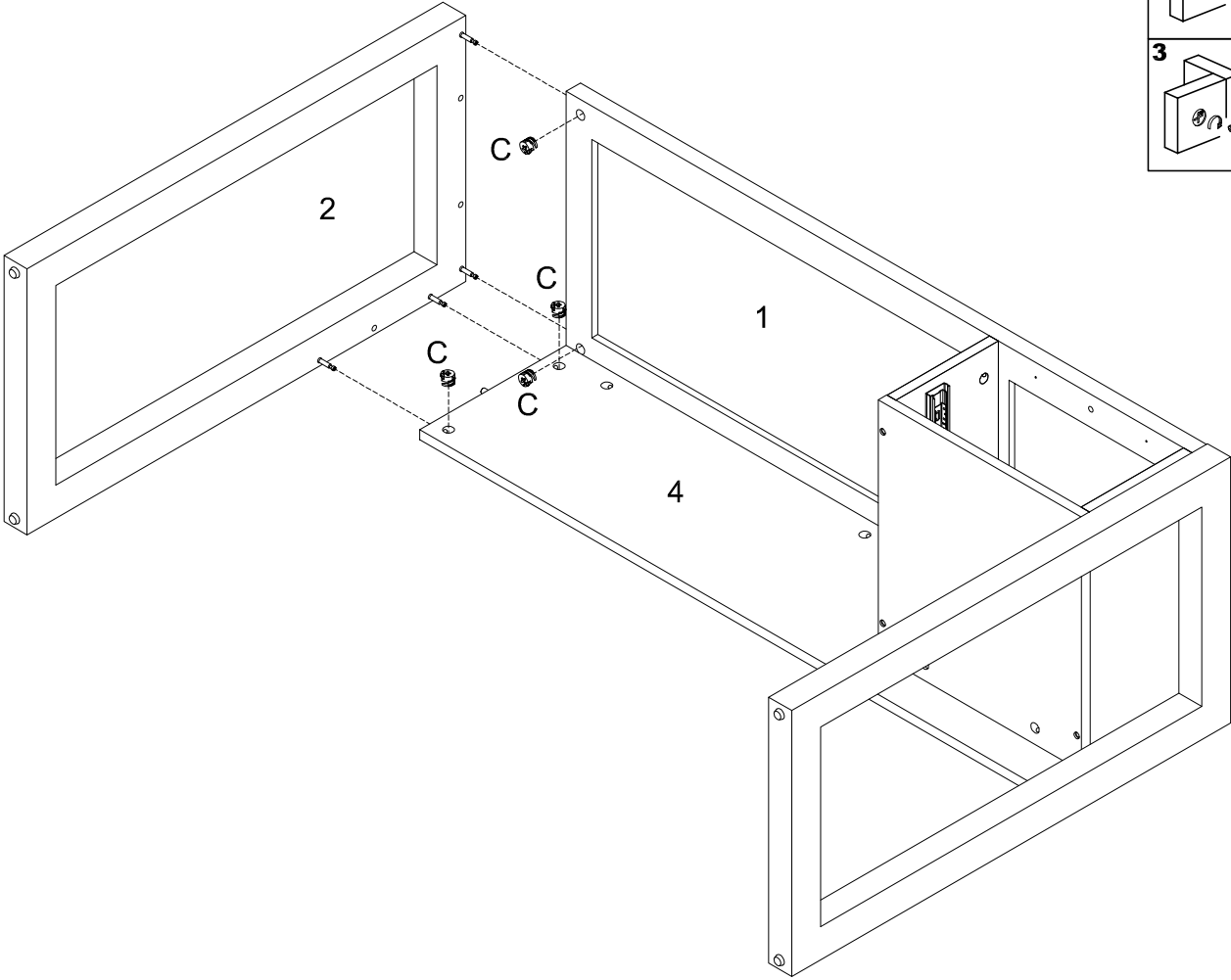

Using cam lock(C) secure part (2) to parts (1,4) with Philips head screwdriver as per diagram.

Step 15

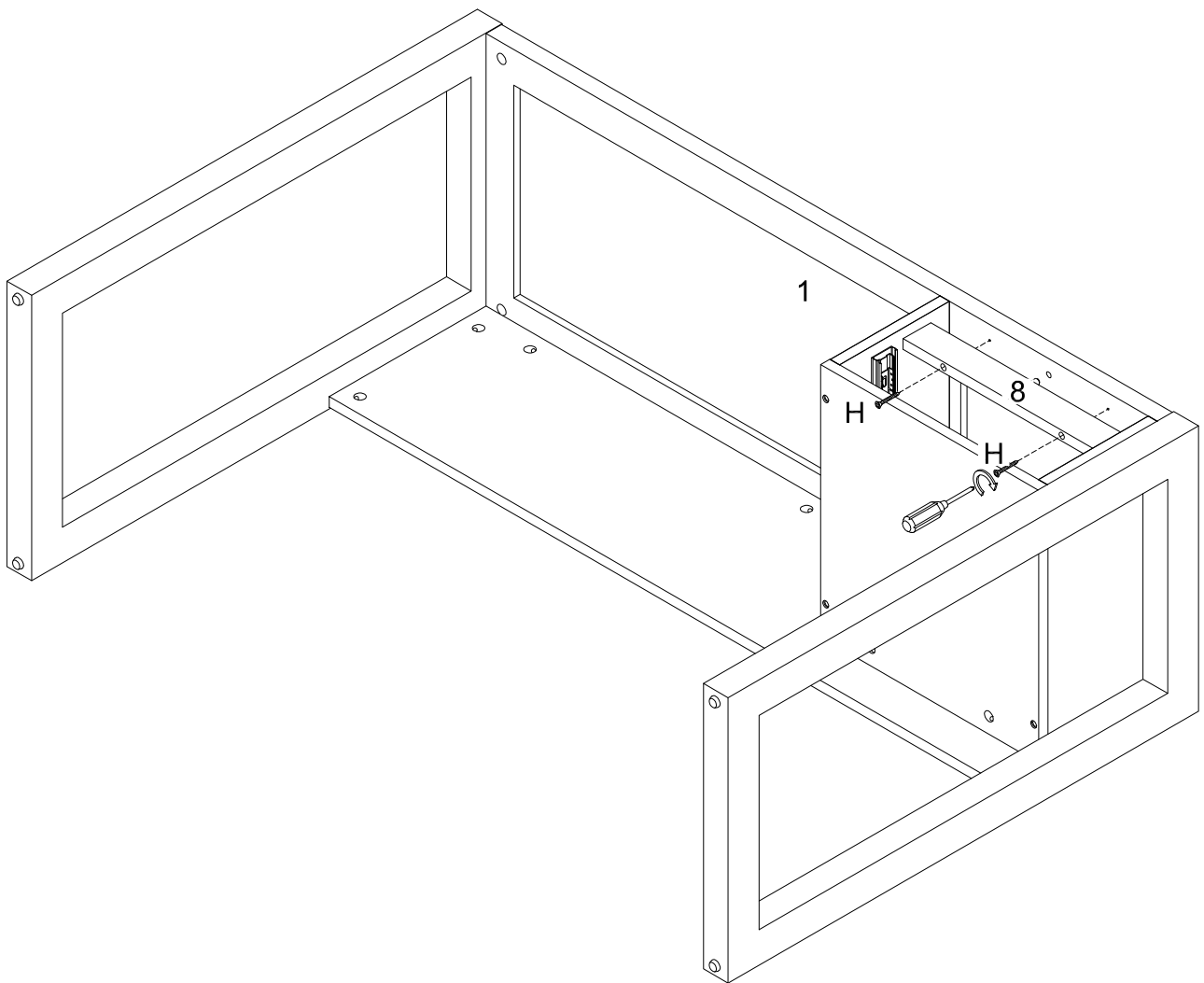

Using screw (H) attach part (8) to part (1) with Philips head screwdriver as per diagram.

Step 16

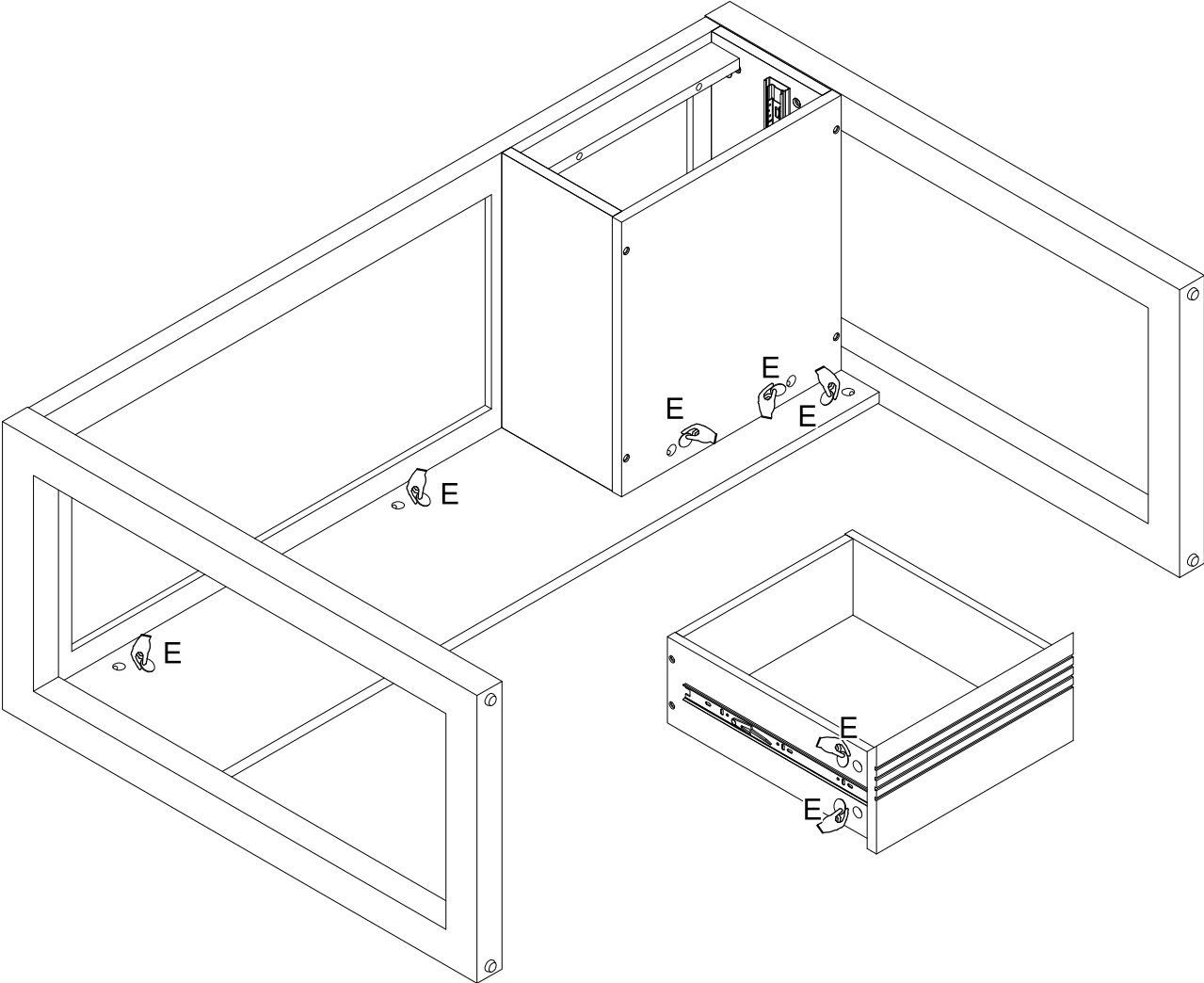

Place sticker (E) cover the holes as per diagram ,and please pay attention on color of sticker.

Step 17

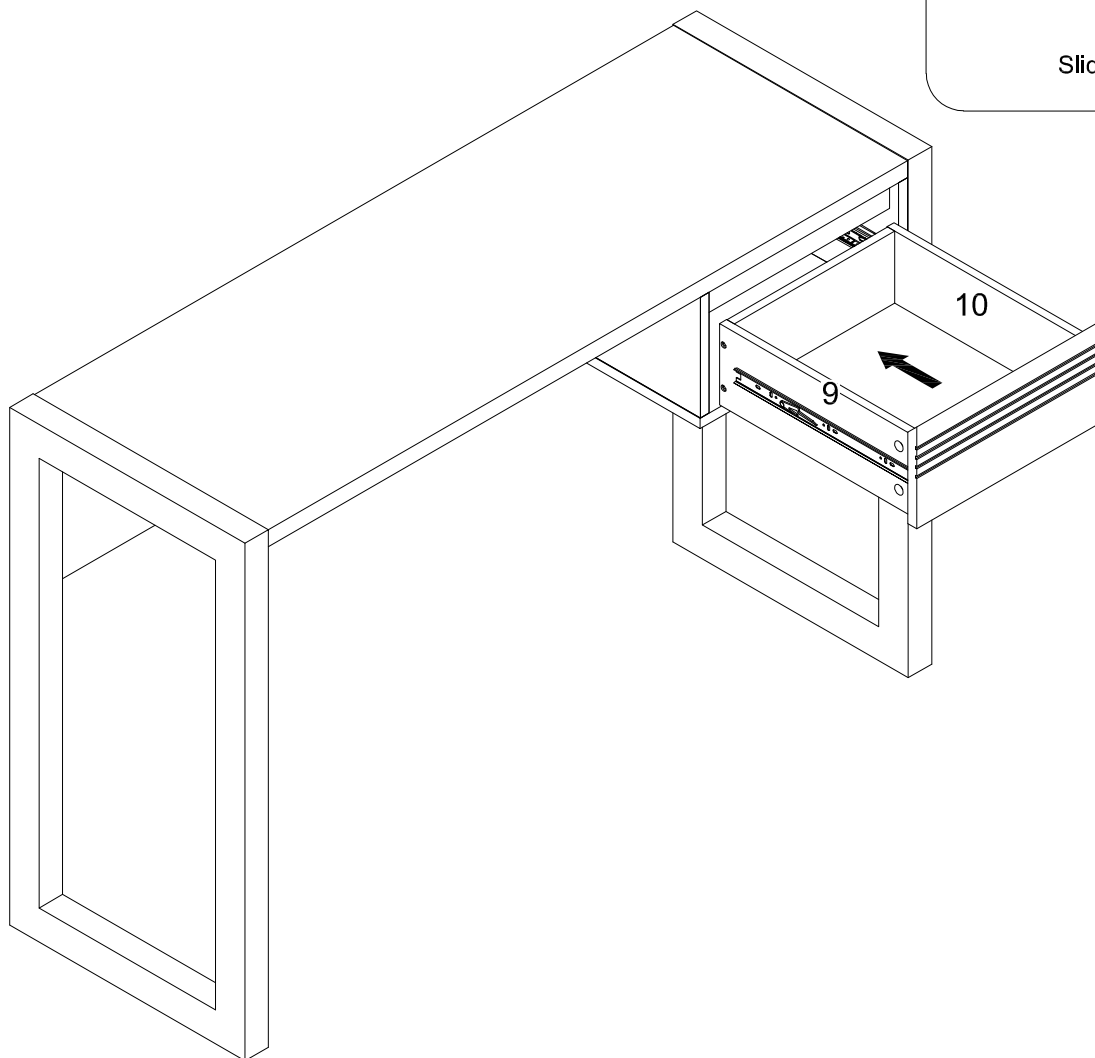
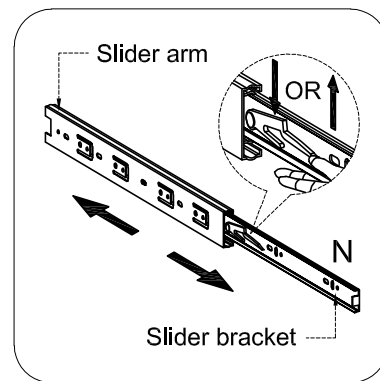

Assembled the drawers as per diagram

Note :If the drawer does not go in smoothly .Press or lift the plastic release lever .

Pull out the slider bracket from the slider arm then re-assembled the drawer until they were going in smoothly well .

Step 18

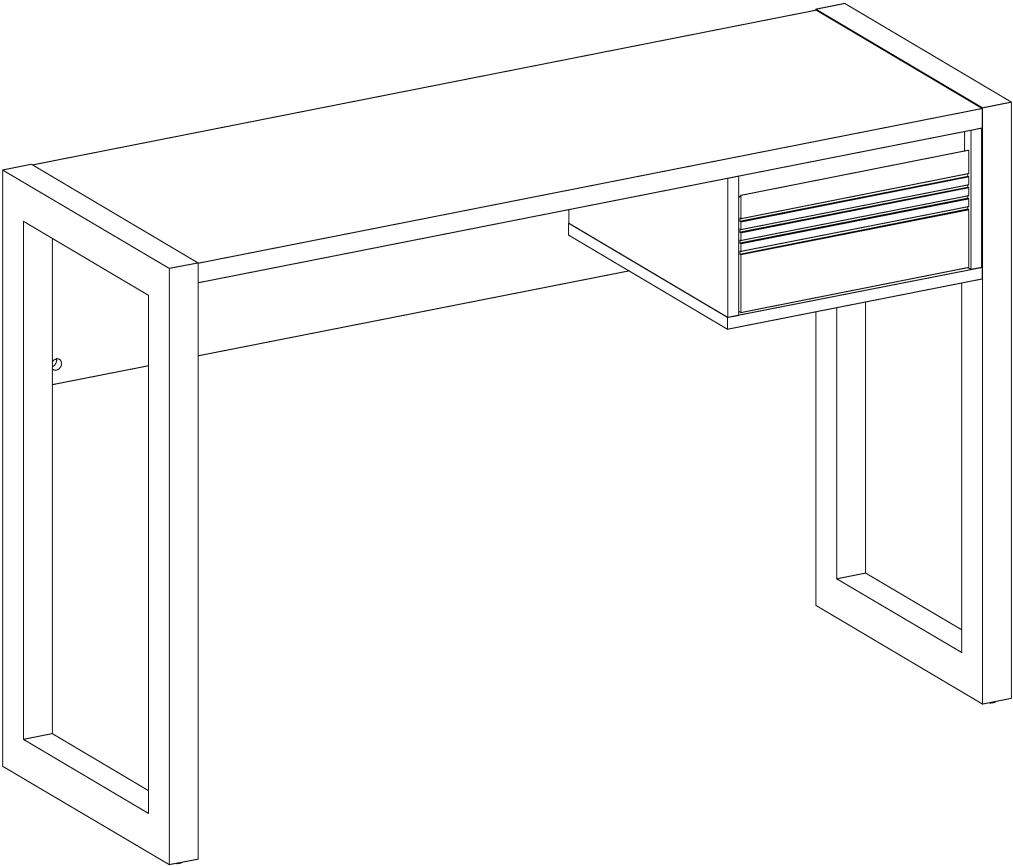

Final Assembly