

*ASSEMBLY INSTRUCTIONS  
COASTER FINE FURNITURE*

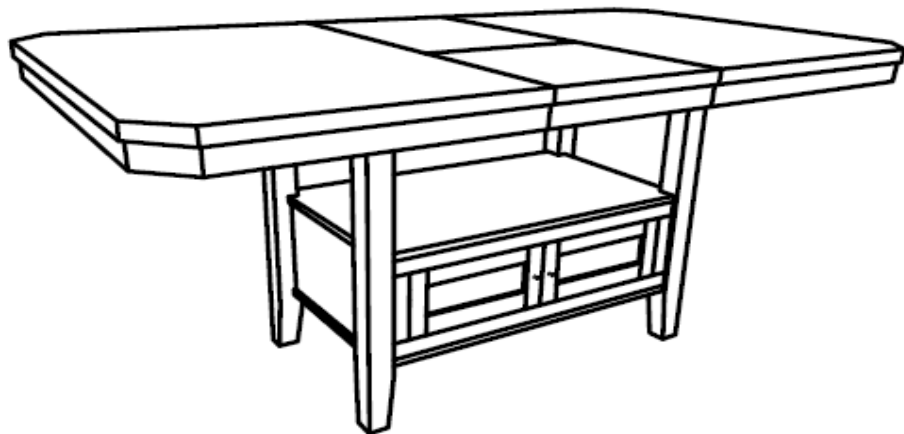

**Counter Height Table**

# ASSEMBLY INSTRUCTIONS

## ASSEMBLY TIPS:

1. Remove hardware from box and sort by size.
2. Please check to see that all hardware and parts are present prior to start of assembly.
3. Please follow attached instructions in the same sequence as numbered to assure fast & easy assembly.



### WARNING!

1. Don't attempt to repair or modify parts that are broken or defective. Please contact the store immediately.
2. This product is for home use only and not intended for commercial establishments.



ASSEMBLY TIME

45 MINUTES

## PARTS IDENTIFICATION

### B1 (BOX 1)

A TOP

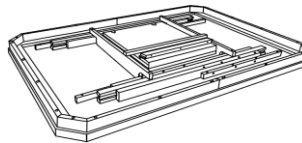

1PC

### B2 (BOX 2)

B LEG FRAME

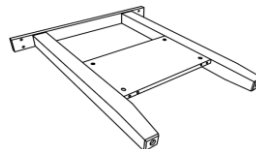

2PCS

C SHELF

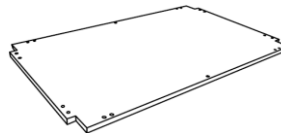

1PC

D DOOR WITH FRAME

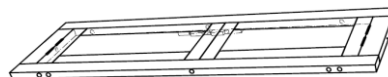

2PCS

E BOTTOM PANEL

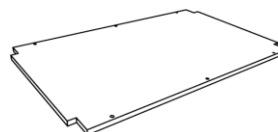

1PC

X KNOB WITH SCREW



4SETS

# ASSEMBLY INSTRUCTIONS

## ASSEMBLY TIPS:

1. Remove hardware from box and sort by size.
2. Please check to see that all hardware and parts are present prior to start of assembly.
3. Please follow attached instructions in the same sequence as numbered to assure fast & easy assembly.











### WARNING!

1. Don't attempt to repair or modify parts that are broken or defective. Please contact the store immediately.
2. This product is for home use only and not intended for commercial establishments.

## HARDWARE IDENTIFICATION

### Z-B1 (BOX 1) - HARDWARE PACK IS LOCATED IN 193108 (B1)

1	<b>ALLEN WRENCH</b> (M4 - BLK)		1PC
2	<b>SHORT BOLT</b> (M6 x 40mm - BLK)		12PCS
3	<b>LONG BOLT</b> (M6 x 50mm - BLK)		8PCS
4	<b>LOCK WASHER</b> (M6 -BLK)		20PCS
5	<b>BIG FLAT WASHER</b> (M6 x 19mm- BLK)		8PCS
6	<b>SMALL FLAT WASHER</b> (M6 x 13mm -BLK)		6PCS
7	<b>PLASTIC DOWEL</b> (M8 x 30mm - BLK)		16PCS
8	<b>FLAT HEAD SCREW</b> (M4 x 38mm- RBW)		4PCS
9	<b>CAM BOLT</b> (34MM - SR)		8PCS
10	<b>CAM NUT</b> (15/15+16 Z1 BRIGH - SR)		8PCS
11	<b>LEVELER</b> (23mm - BLK)		4PCS

### NOTE:

Phillips head screw driver is required in the assembly process; however, manufacturer does not provide this item.

# ASSEMBLY INSTRUCTIONS

## STEP 1

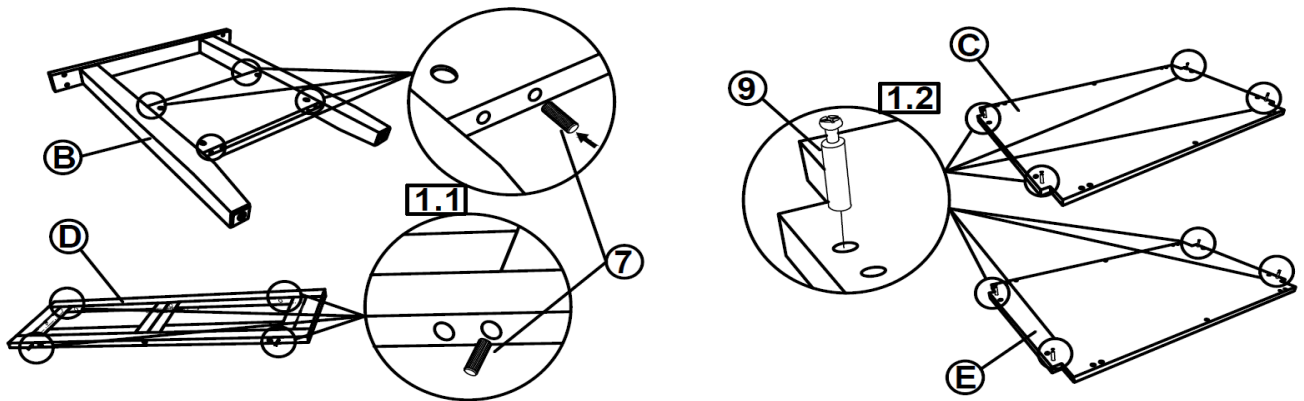

## STEP 2

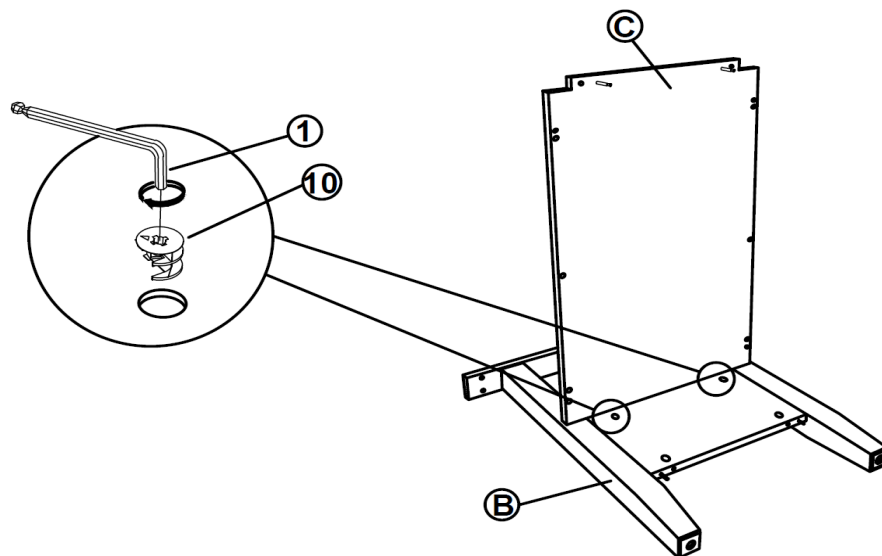

## STEP 3

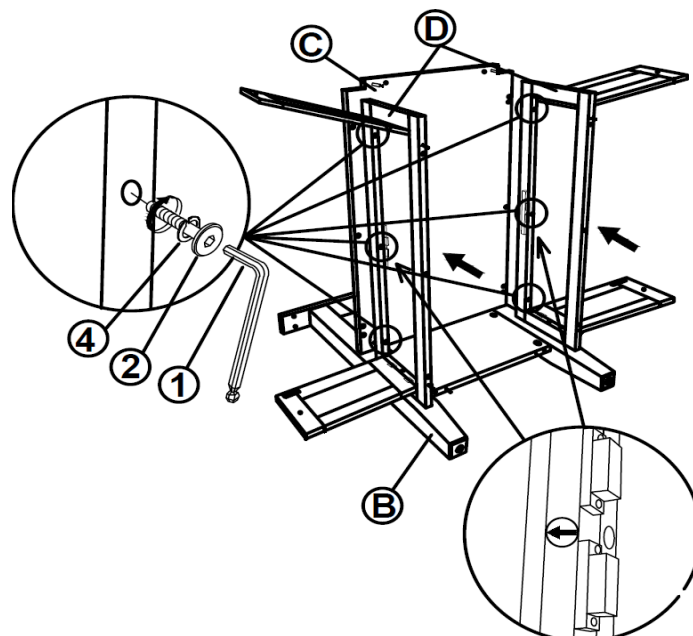

# ASSEMBLY INSTRUCTIONS

## STEP 4

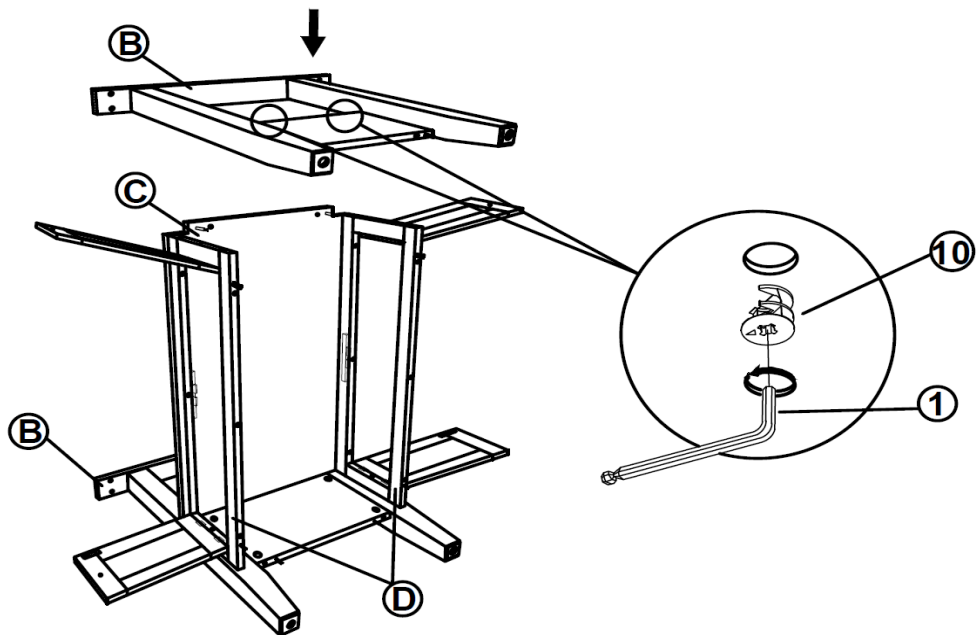

## STEP 5

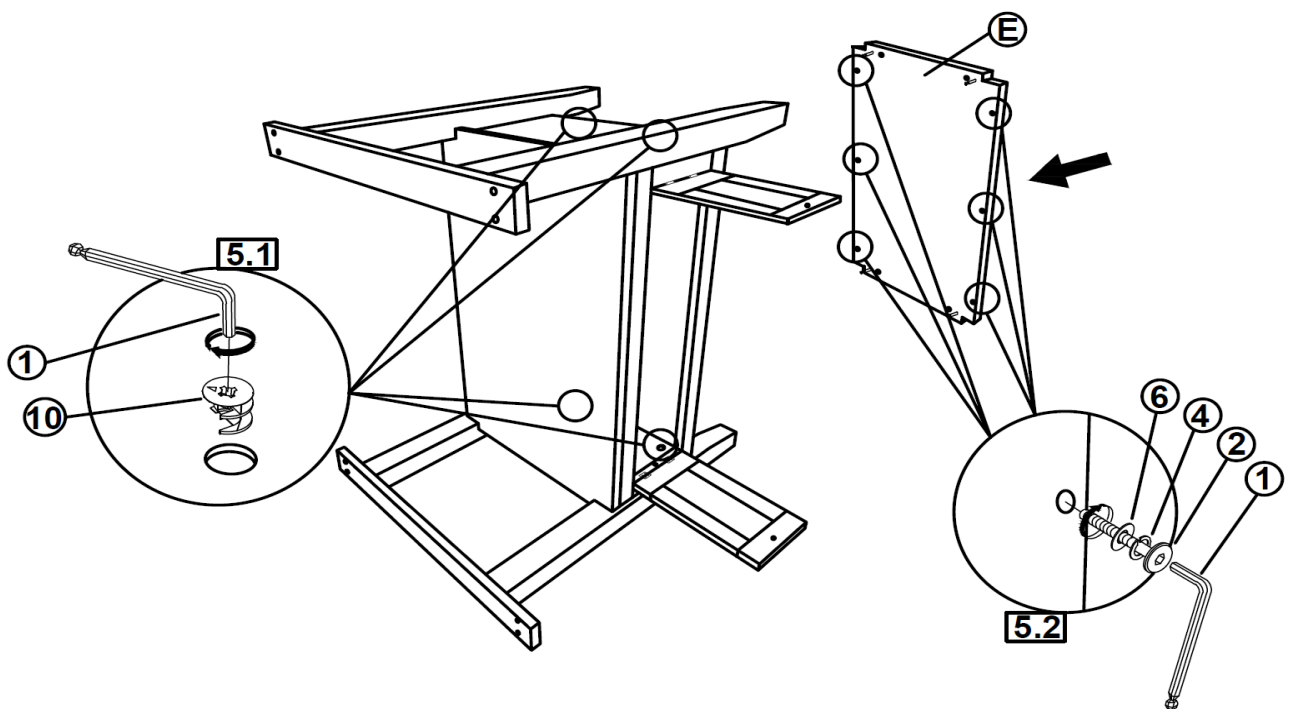

# ASSEMBLY INSTRUCTIONS

## STEP 6

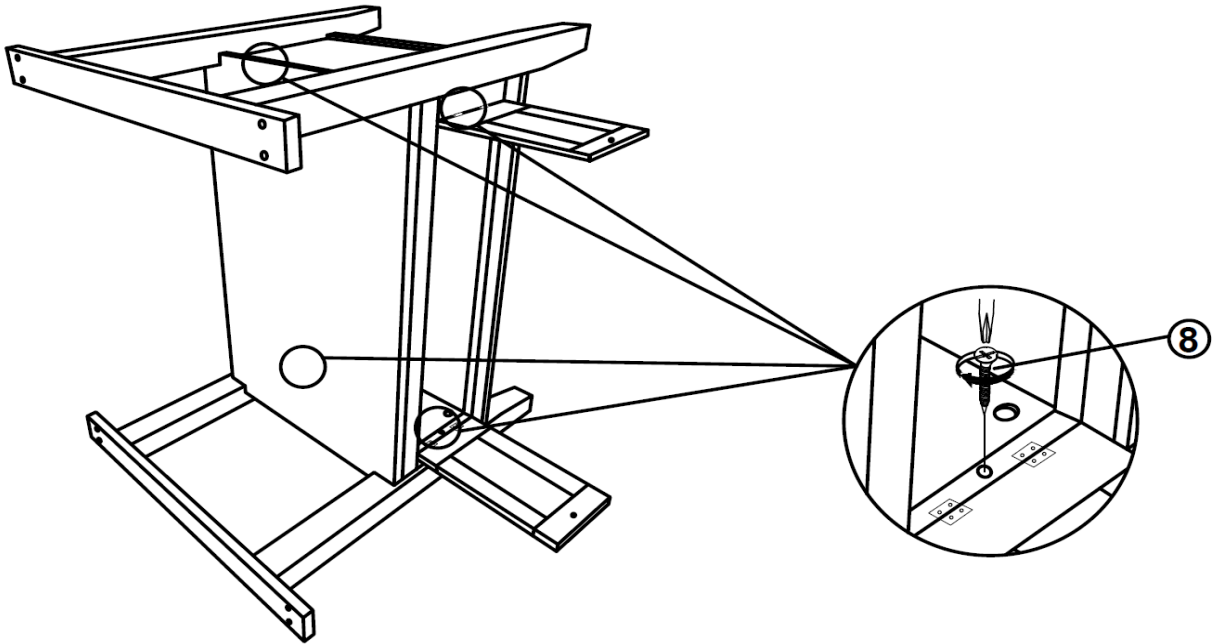

## STEP 7

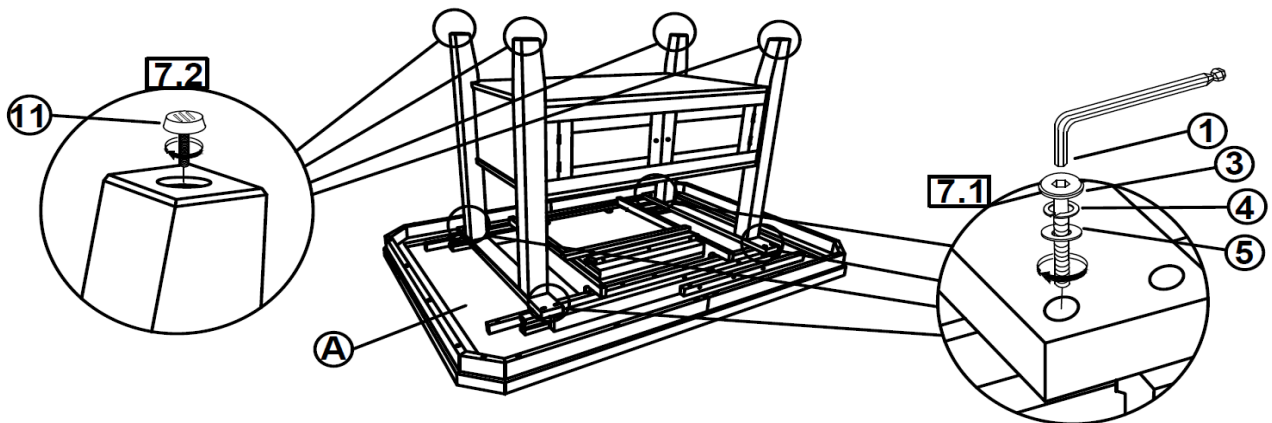

# ASSEMBLY INSTRUCTIONS

## STEP 8

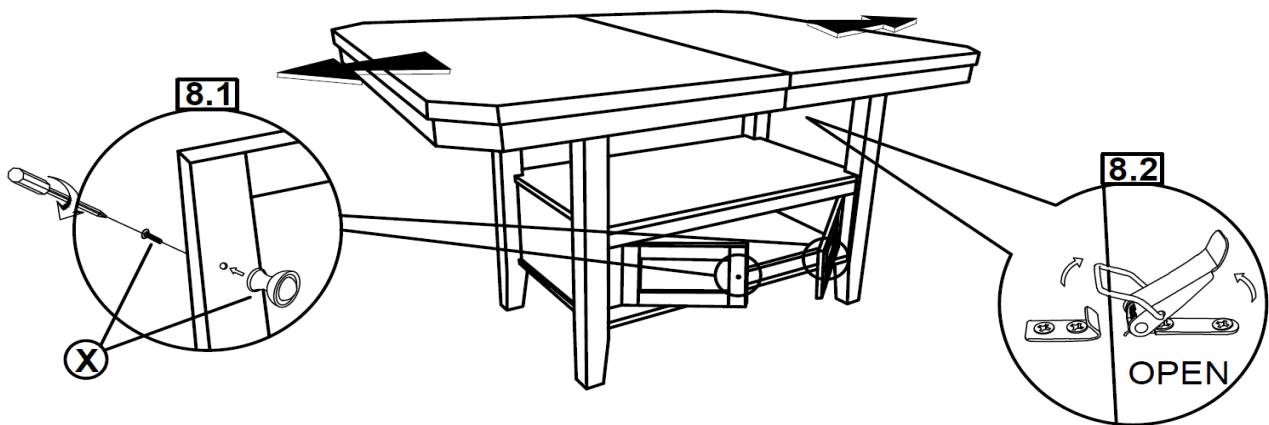

## STEP 9

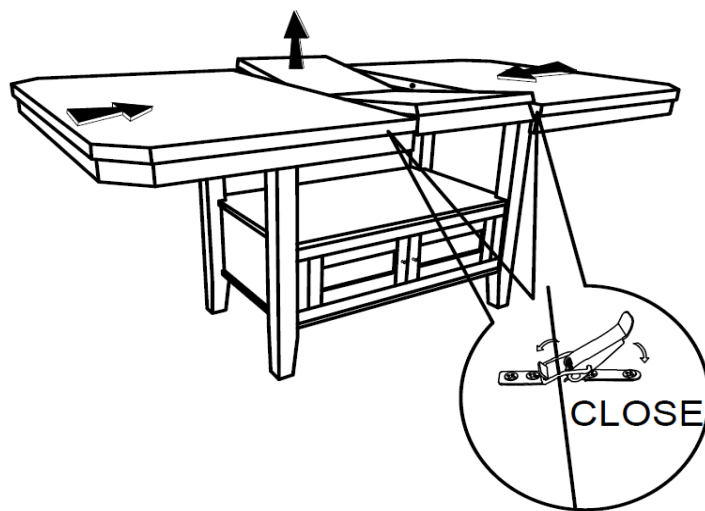

## STEP 10

### COMPLETE

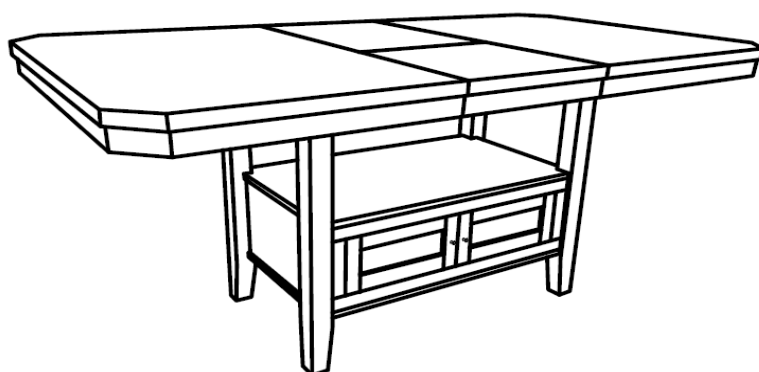

# ITEM: 193108(B1&B2)

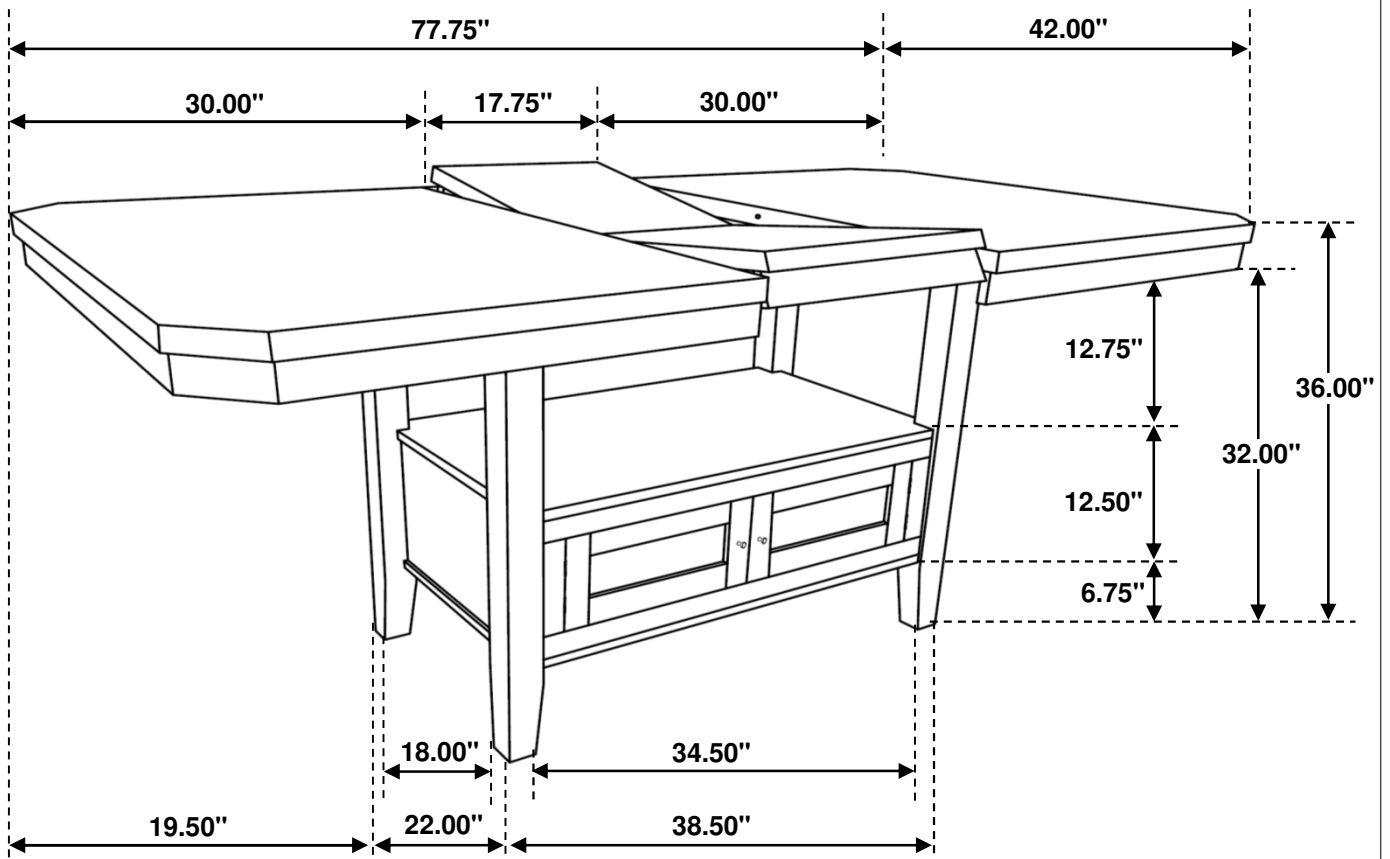

Note: Dimension tolerance  $\pm 5\%$