



Assembly Instructions

Caution : You must read this before you proceed





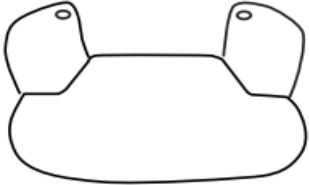
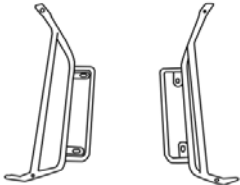

Rocking Chair



Parts List

Label	Picture	Description	QTY
A		Chair Backrest	1
B		Seat Base	1
C		Iron Frame	1
D		Wooden Leg	2

Hardware

Label	Picture	Description	QTY
①		Bolt(M6*50mm)	2
②		Spring Washer (M8)	2
③		Flat Washer (M8*24)	2
④		Allen Washer (S6)	1
⑤		Bolt(M8*25mm)	4
⑥		Bolt(M6*20mm)	4
⑦		Black Felt Strip	2

Assembly Preparation

Before Beginning Assembly:

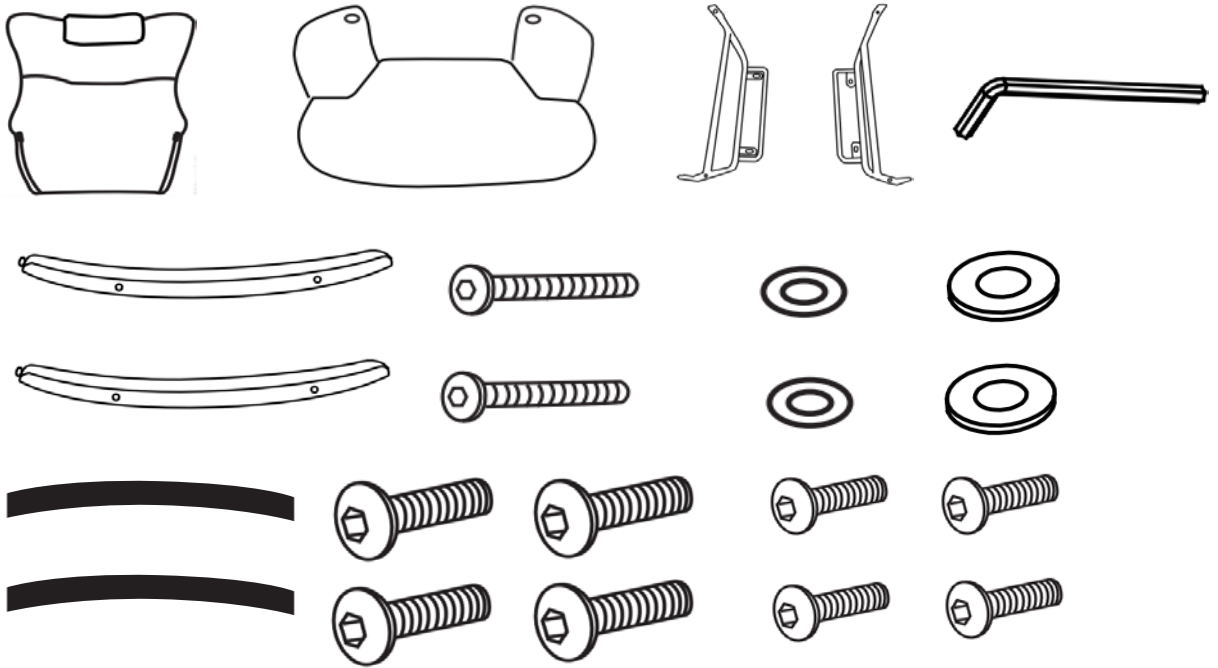

- Read instructions, cover to cover-



- Have 2 adults on hand for assembly-



- Do not assemble on flooring or carpet-



- Assemble on a clean non-marring surface (packing foam)-



- Save all packaging until finished-

Assembly Steps

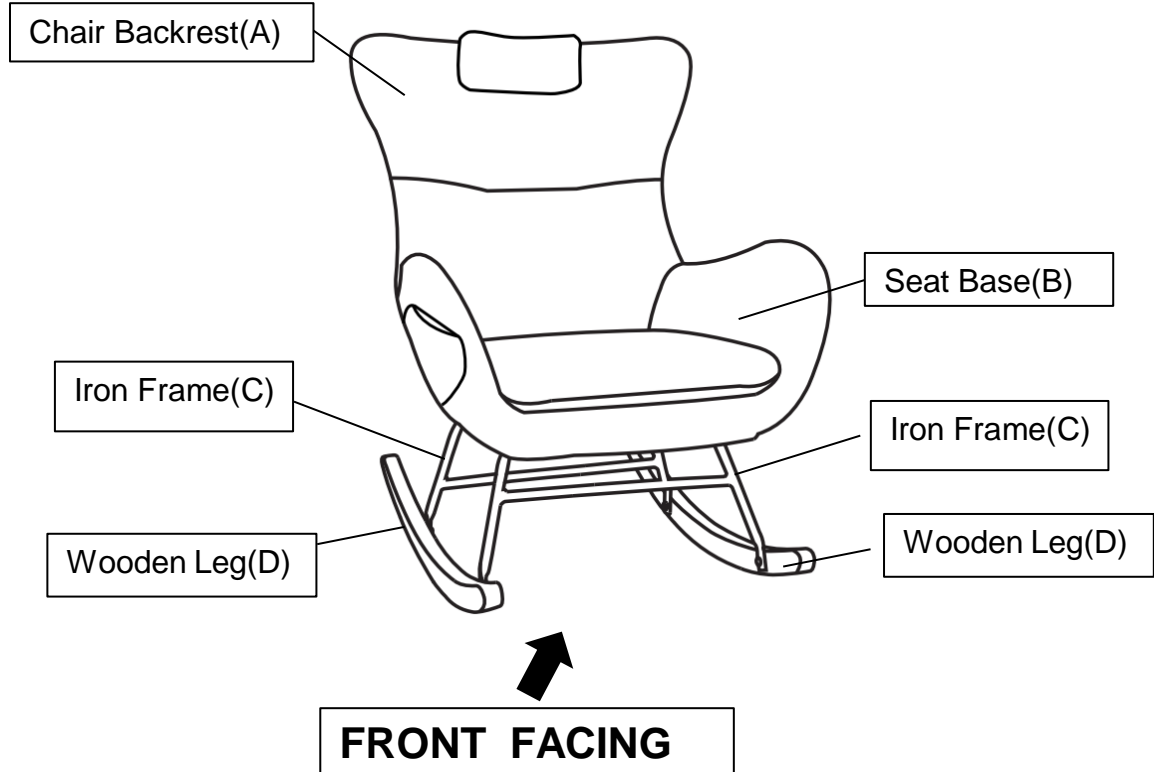

This Rocking Chair has multiple parts and may require up to 30 minutes to assemble. To give you an overview of the Rocking Chair parts, the above picture is to help you put the various parts into perspective. Please read through the instructions below to familiarise yourself with the parts and steps before assembly.

Step 1

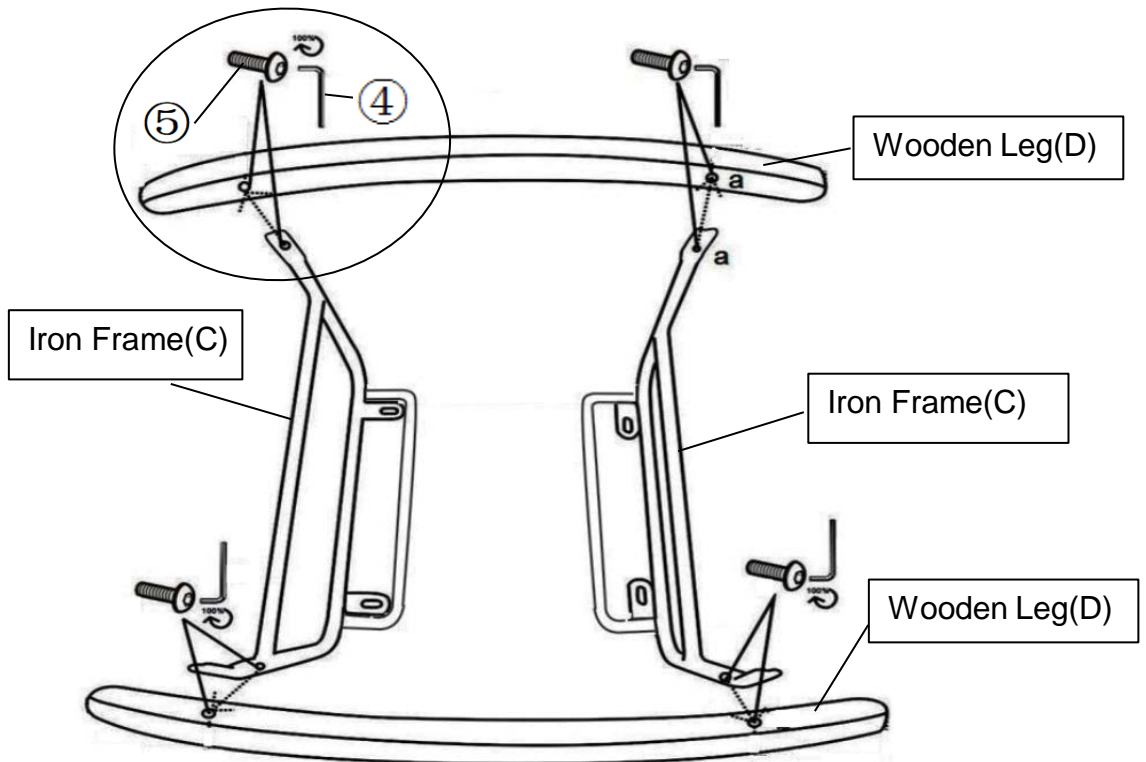

Attach the the Iron Frame(C) to Wooden Leg(D) ,Using Bolt(⑤),With Allen Washer(④) as shown above.

Step 2

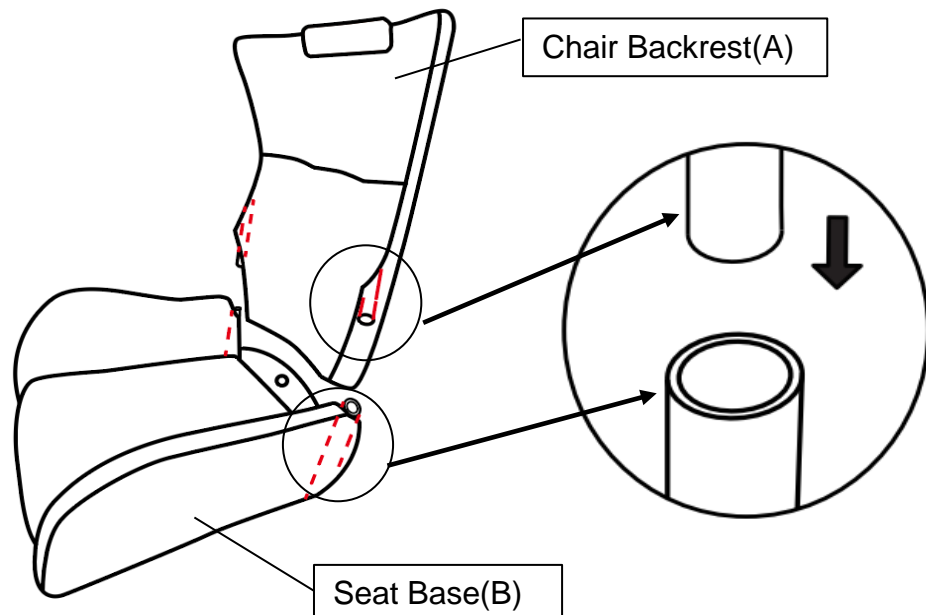

Slide the Chair Backrest(A) into Seat Base(B) form the holes in two end sides as shown in the picture.

Step 3

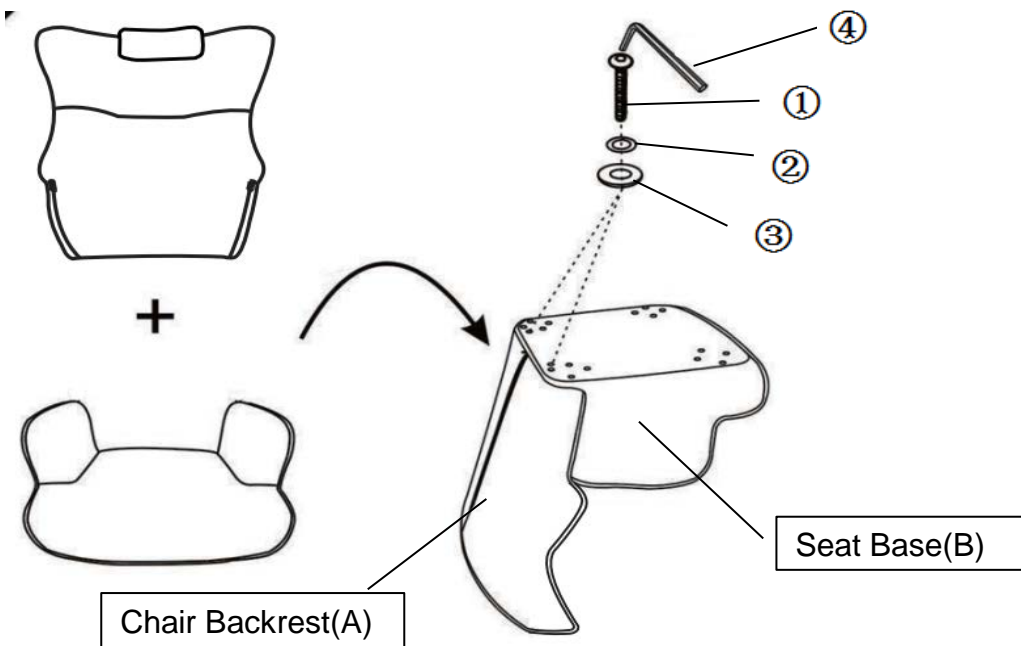

Using Bolt(①),Spring Washer(②),Flat Washer(③) With Allen Washer(④) tighten Seat Base(B) to Chair Backrest(A) as shown above.

Step 4

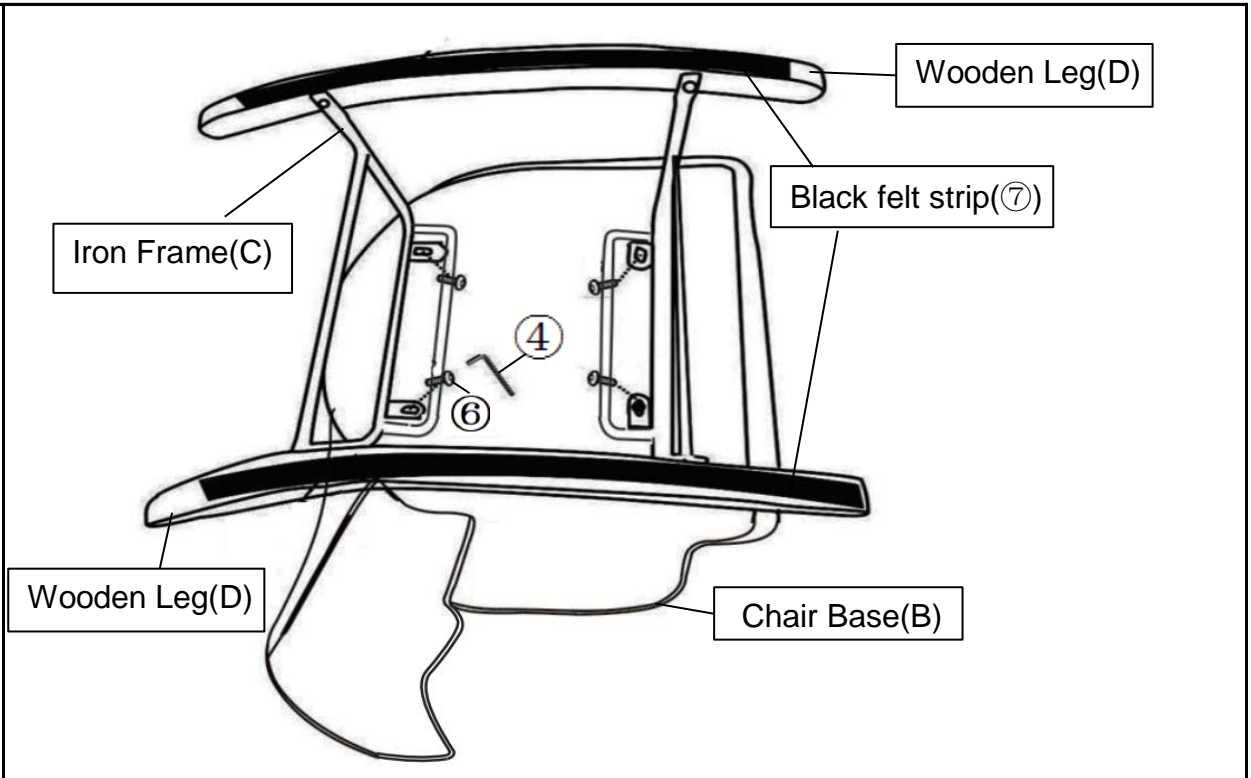

Attach the the Iron Frame(C) to Chair Base(B) ,Using Bolt(6),With Allen Washer(4).

Take off the viscose cloth on Black felt strip(7) and stick Black felt strip(7) to along the bottom of the Wooden Leg(D).

Tighten all the Bolts by Allen Washer(4).

Step 5

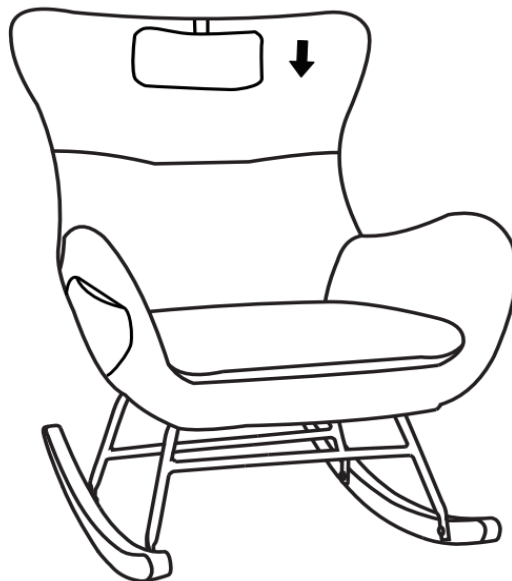











The Rocking Chair headrest can be adjusted up and down.

Your Rocking Chair is ready for use.

This Rocking Chair can only be used on a flat, level surface.



Care & Maintenance

- ✓  • Furniture may scratch floors. We recommend using furniture pads to protect your floors.
- ⊘  • Do not put hot items directly on furniture surface.
- ⊘  • Do not clean furniture with harsh cleansers or polish.
- ⊘  • Do not place furniture under direct sunlight.
- ⊘  • Do not place furniture near heating or cooling vents.
- ⊘  • Do not write on furniture without a padded barrier to protect the surface.
- ⊘  • Do not place furniture outside . For indoor use only.
- ⊘  • Not for commercial use. For residential use only.
- ⊘  • Stains may be removed with mild soap solution and damp cloth.
- ⊘  • Children should not climb or jump on the furniture.
- ✓  • Dust and pick-up spills using a clean, non-colored, lint-free cloth.