

Assembly Instruction

Go to **Care + Maintenance** selection.

Tools Required: Flathead screwdriver, Phillips screwdriver, pliers, wire cutters, wire strippers, electrical tape, safety glasses.

Light Source: (1) A21 Medium Base bulb 150W Maximum or
(1) Medium Base Vintage bulb is recommended but not supplied.

Estimated Assembly Time: 20-30 minutes

Preparation: Identify and inspect all parts before beginning installation. Check package content list and diagrams below to be sure all parts are present. If any parts are missing or damaged, do not attempt to assemble, install, or operate the fixture. Contact customer service for replacement parts.

⚠ Warnings and Cautions

Turn off electricity at circuit breaker or main fuse box before installation. Consult a licensed electrician if in doubt.

These instructions are provided for your safety. It is very important you read them completely before installing the fixture. We strongly recommend that a licensed, professional electrician perform the installation.

Disconnect fixture from power source before replacing bulbs. Make sure bulbs are given sufficient time to cool before removal.

Package Contents

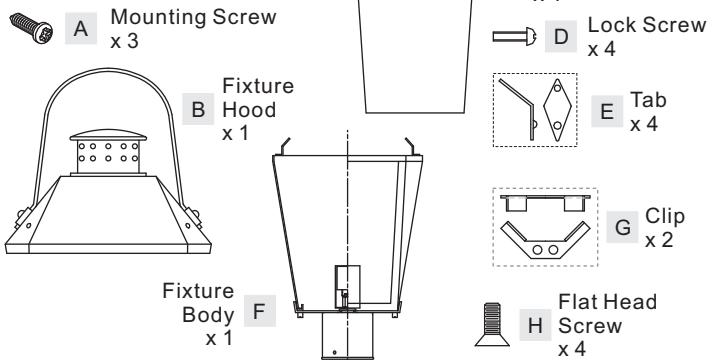

STEP 2 – Drill Pilot Holes on Post

- Carefully fit the Post Fitter over the end of the Post (not supplied), making sure the Post Fitter is fully seated.
- Mark the drill point for the (3) Mounting Screws, using (3) Mounting Holes as reference. After marking hole locations, remove fixture from post and drill 1/16" pilot holes for screws.

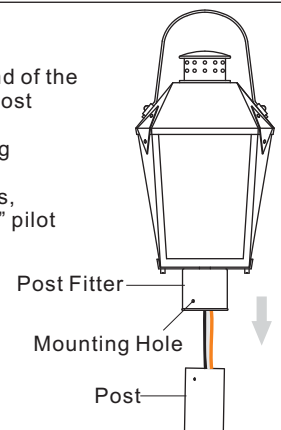
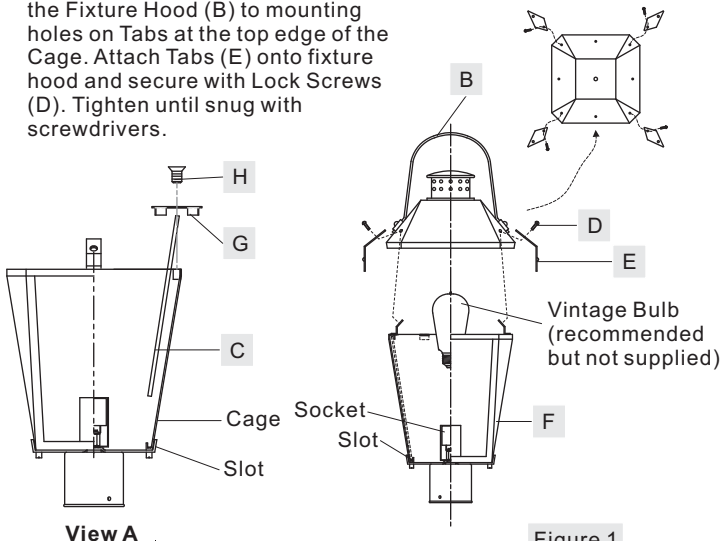

Figure 2

STEP 1 – Install Bulb and Fixture Hood

- Insert Glass Panels (C) into the slot in the bottom edge of the Cage properly. Place Clips (G) on the top edge of the Cage to hold Glass Panels (C), secure by threading Flat Head Screws (H) onto Cage. Tighten until snug. **(See view A)**
- Insert bulb onto socket and screw snugly into place
- Attach Fixture Hood (B) onto top edge of Cage and align holes on the Fixture Hood (B) to mounting holes on Tabs at the top edge of the Cage. Attach Tabs (E) onto fixture hood and secure with Lock Screws (D). Tighten until snug with screwdrivers.



View A

Figure 1

STEP 3 - Wire Connections

- Use standard wire connectors (not included) to make all wire connections. Twist connectors until wires are tightly joined together. Wrap each connection with approved electrical tape and carefully stuff all the connected wires into the Outlet Box.

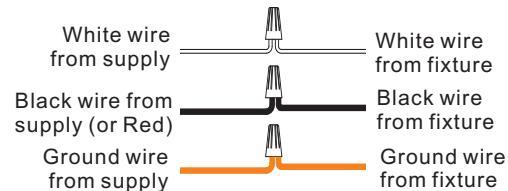

Figure 3

STEP 4 – Attach Fixture Body to Post

- Coat the top 1" of the Post with Clear Silicone Caulk (not supplied) and position the Post Fitter onto the Post. Be sure to seat it completely, aligning the holes in the Fitter with the 1/16" Pilot Holes drilled into the Post.
- Secure the Fixture to Post with (3) Mounting Screws (A).

Your fixture is now assembled and ready to use. Enjoy!

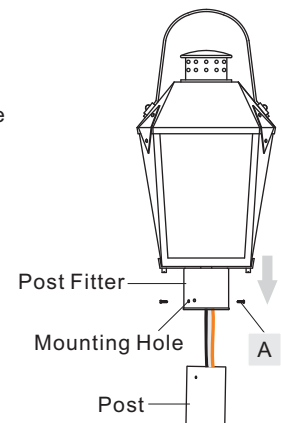
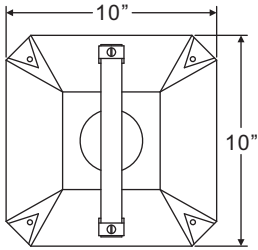
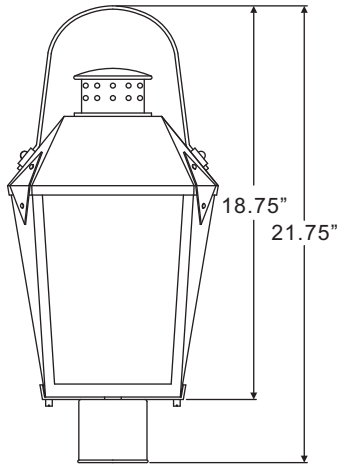
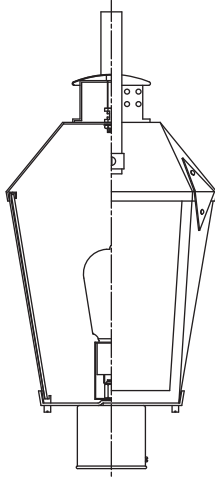

Figure 4

FINISH: MOTTLED BLACK



NOTE: ALL DIMENSIONS ARE ROUNDED UP TO THE NEAREST 1/4"