

Triple Roof Flight Cage

read first REVIEW BEFORE ASSEMBLY

- **TOOLS:** No tools are required. For assistance or replacement parts, please contact us

step 1 PARTS USED:

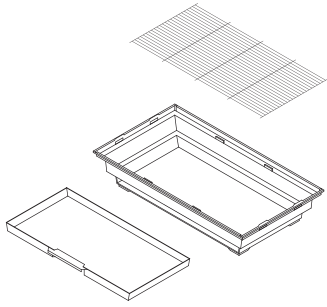

Removable tray will already be in the base.

Place grille into base before adding mesh.

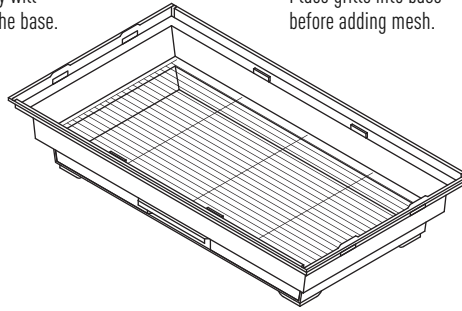

step 2 PARTS USED:

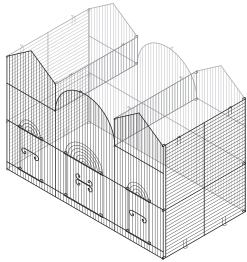

Unfold the cage mesh unit so that the corners make 90° right angles.

Place the cage body into the base. Starting at one end, align the loops on the mesh with openings in the base.

Guide the mesh in place between the edge and the tabs along the inner rim of the base.

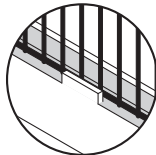

Finish with putting the loops into base openings on the opposite end.

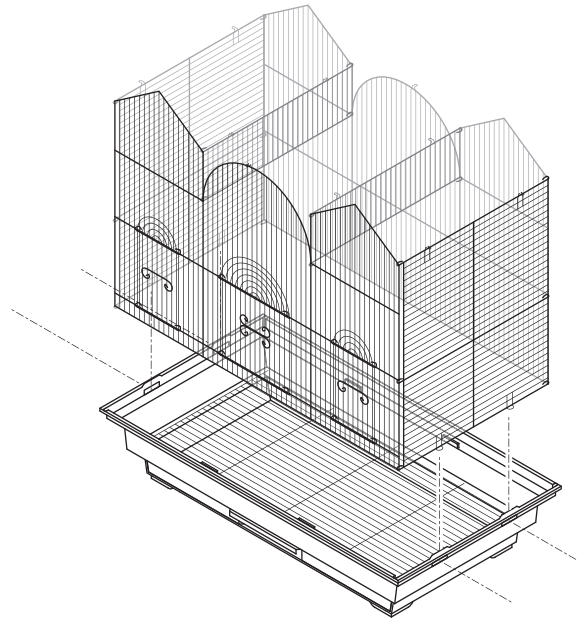

step 3

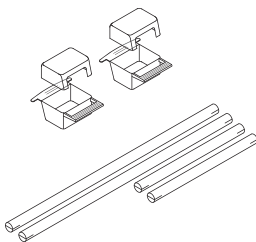

Insert two short perches as illustrated.

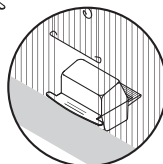
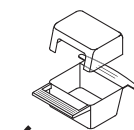
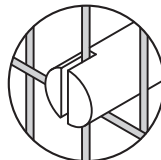

Assemble and insert two food/water cups as illustrated.

Insert two long perches as illustrated.

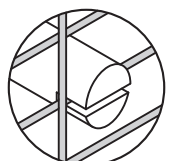

step 4 PARTS USED:

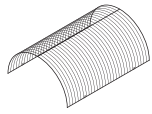

Install the roof, starting with the middle arch.

There are two loops on each bottom rail of the arched roof unit.

There is one loop at the peak of the body mesh, in front and back.

Flex the arched roof so that the lower loops catch underneath the short vertical panels on the cage body.

Catch the arched roof at the top onto the loops of the cage body, front and back.

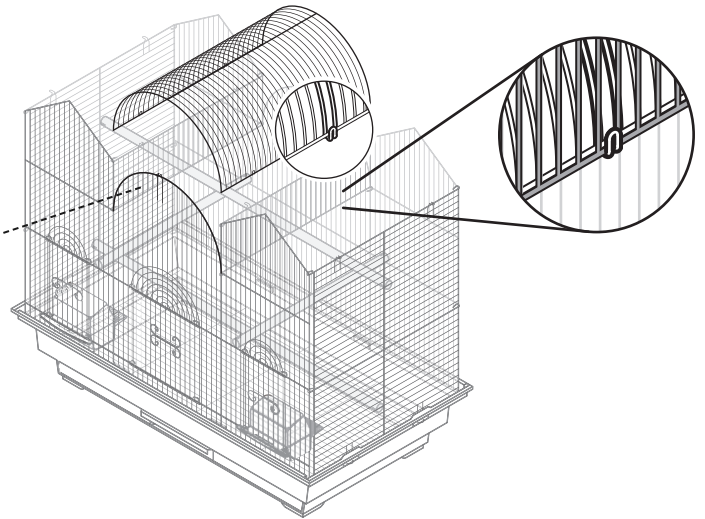

step 5 PARTS USED:

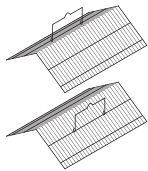

Finish by installing the two peaked roofs.

There are two loops on each top inside and outside rail of the cage body.

For each peaked roof unit, hook the second horizontal wire onto the loops of the cage mesh—start with inside loops first, then move to outside loops.

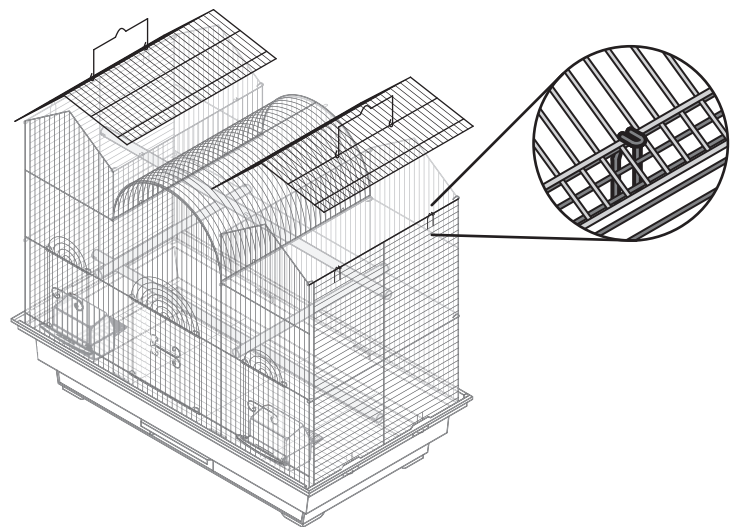

CLEANING INSTRUCTIONS

Prolong the life of your cage with these recommendations:

- When cleaning the cage and parts, use a soft cloth or Teflon-resistant scrubber (such as **our Cage Saver** non-abrasive scrub pad (#109)).
- Wash all parts with warm water and a mild environmentally-friendly, pet-friendly soap.
- Rinse thoroughly.
- Hand dry all parts completely with a soft dry cotton cloth before reassembling the cage.
- Do not leave plastic parts to dry in the sun as they may warp.

