

# ASSEMBLY INSTRUCTION

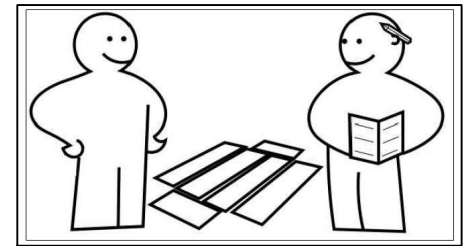

Attention:  
Two people are required for  
assembly and lifting unit.

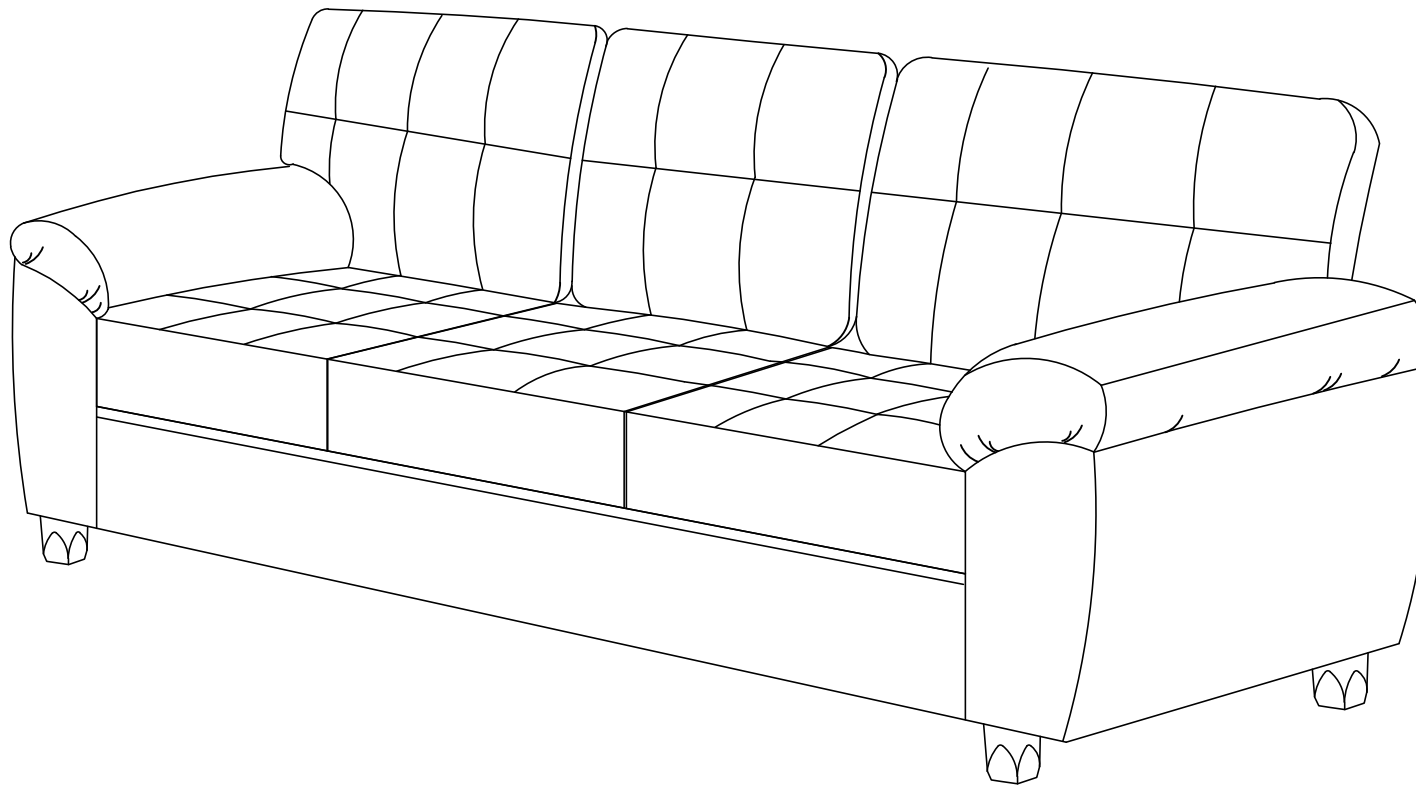

# HARDWARE LIST

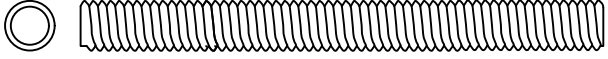
	
A	12PCS
THREADED RODS 5/16 x 75mm	

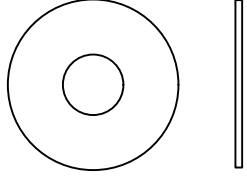

	
B	12PCS
Nut 5/16 x 12mm	

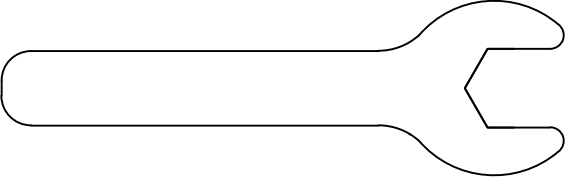
	
C	12PCS
Flat Washer 5/ 16 x 25mm	

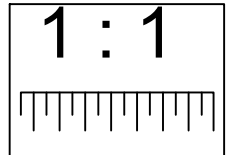
	
D	1PC
Spanner	

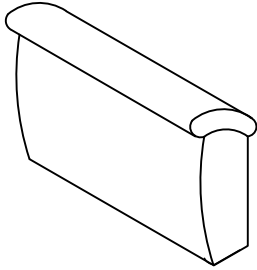
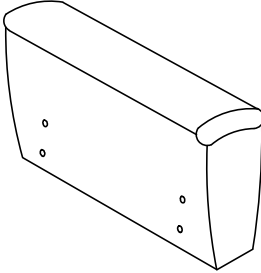
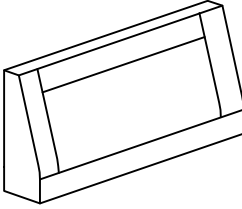
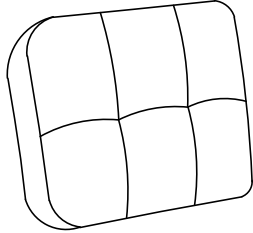
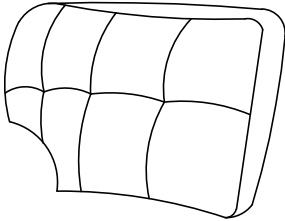
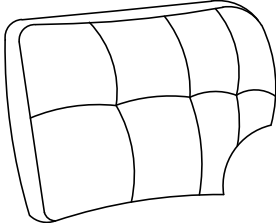
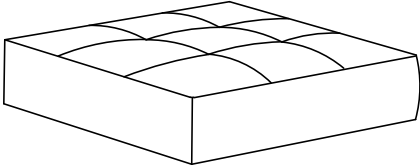
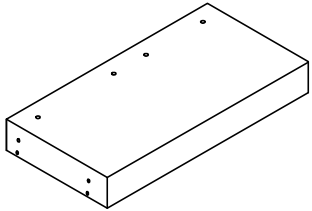

# PART LIST

<p><b>P1</b></p>  <p>ARM REST - LEFT (1PC)</p>	<p><b>P2</b></p>  <p>ARM REST - RIGHT (1PC)</p>	<p><b>P3</b></p>  <p>BACK REST (2PCS)</p>	<p><b>P4</b></p>  <p>BACK CUSHION - CENTER(1PC)</p>
<p><b>P5</b></p>  <p>BACK CUSHION - LEFT(1PC)</p>	<p><b>P6</b></p>  <p>BACK CUSHION - RIGHT(1PC)</p>	<p><b>P7</b></p>  <p>CUSHION SEAT (3PCS)</p>	<p><b>P8</b></p>  <p>SEAT BASE (1PC)</p>
<p><b>P9</b></p>  <p>PLASTIC LEG (4PCS)</p>			

# ASSEMBLY INSTRUCTION

## STEP 1.

Open the cover cloth located behind the Seat Base (P8) (1pc) and remove all part and hardware.

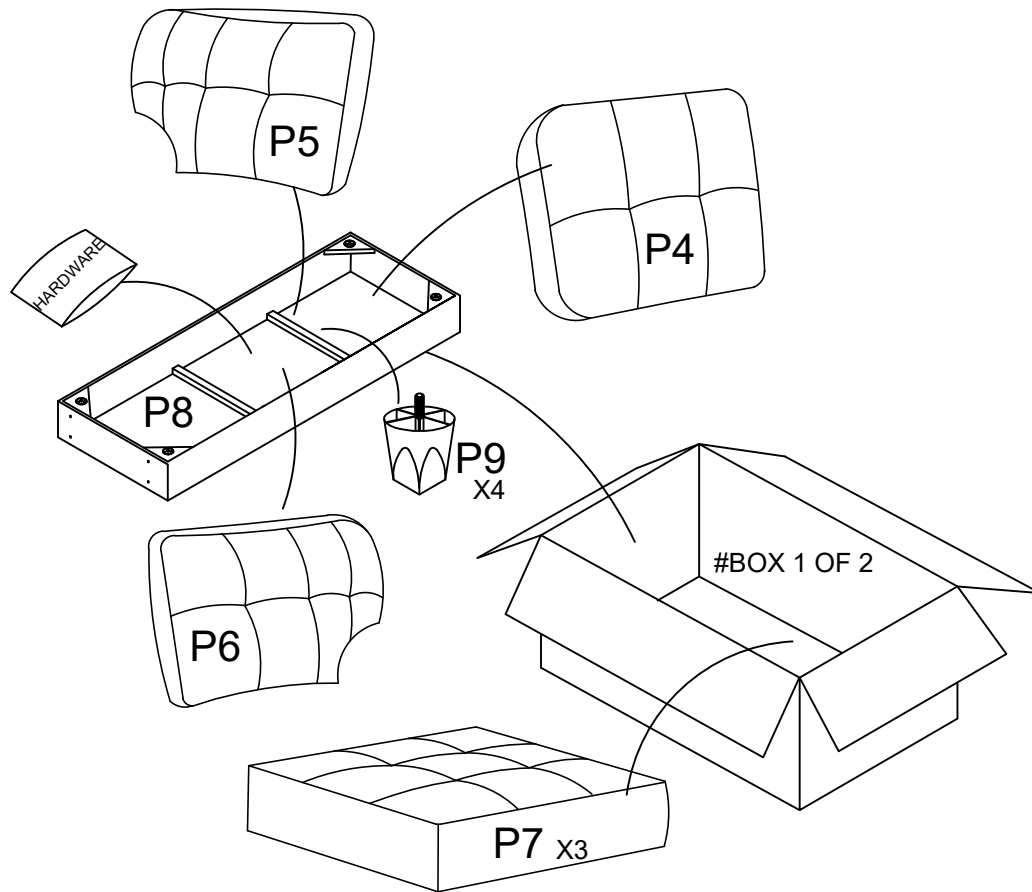

## STEP 2.

Remove all part from the box.

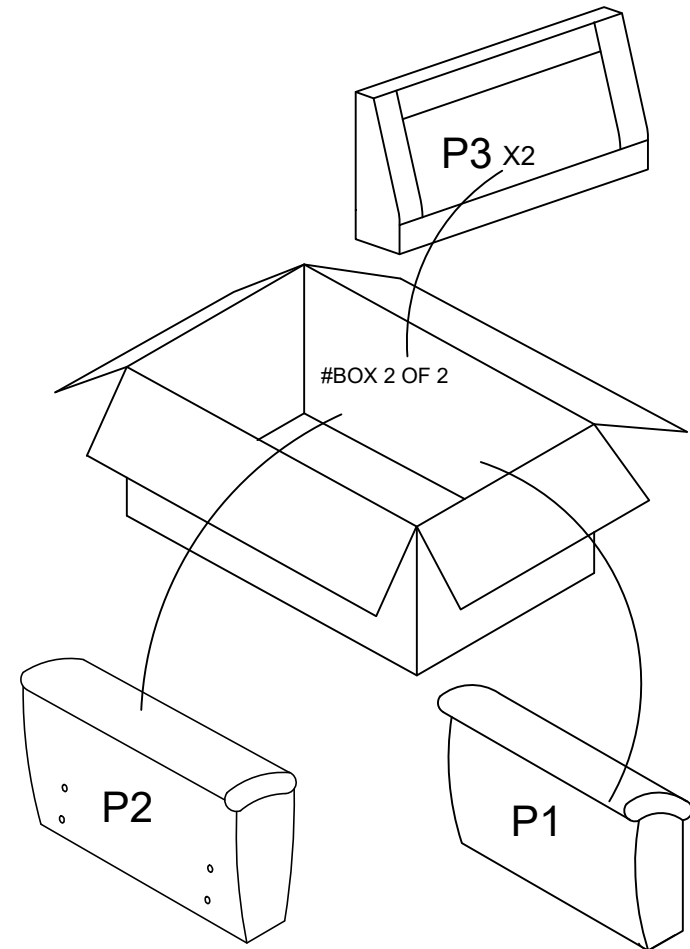

# ASSEMBLY INSTRUCTION

## STEP 3.

Attached the Threaded Rods (A) (12pcs) to Back Rest (P3)(2pcs) and Arm Rest (P1&P2) (2pcs).

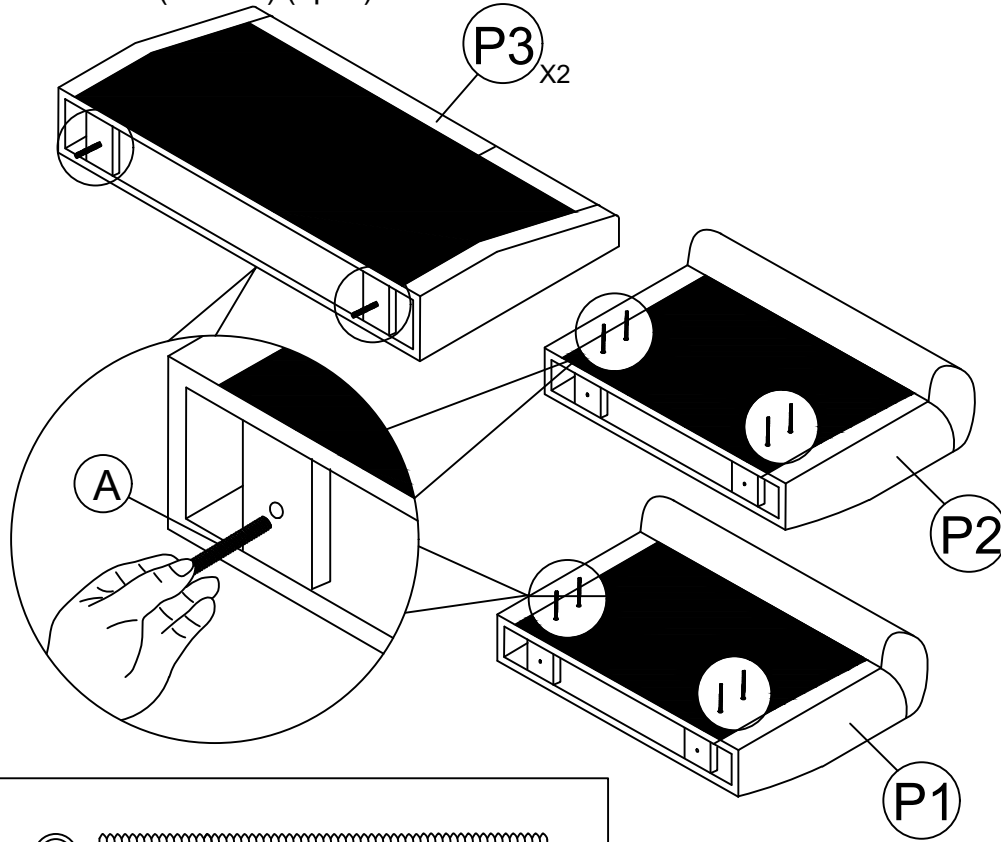

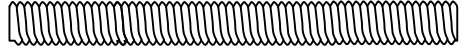
	
A	12PCS
Threaded Rod 5/16 x 75mm	

## STEP 4.

Attached the Back Rest (P3) and Arm Rest (P1 & P2) to the Seat Base (P8)(1pc)

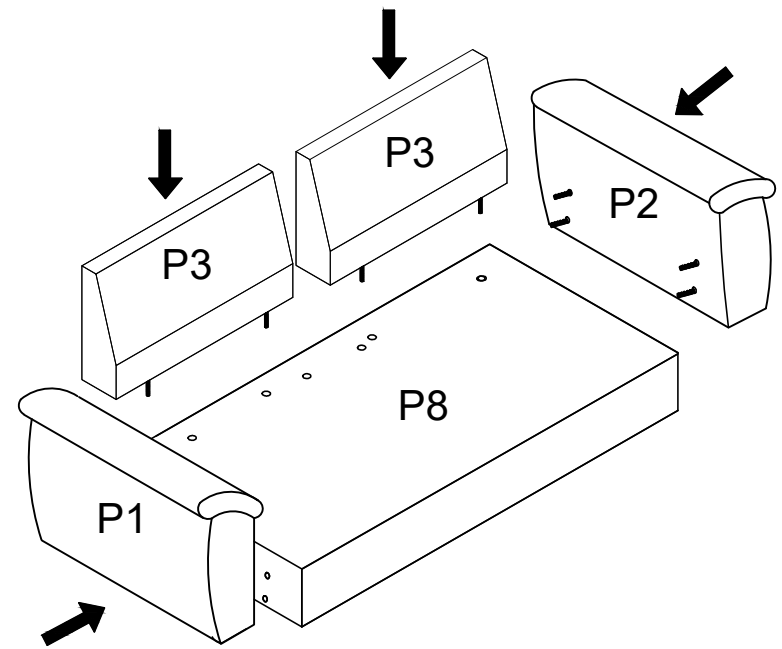

# ASSEMBLY INSTRUCTION

## STEP 5.

Attached the Back Rest (P3), Arm Rest (P1&P2) to Seat Base (P8) (1pc).  
Used Flat Washer (C) (12pcs), Nut (B)(12pcs) and Spanner(D) to assemble.  
Make sure the bolts are fully tighten and secure.

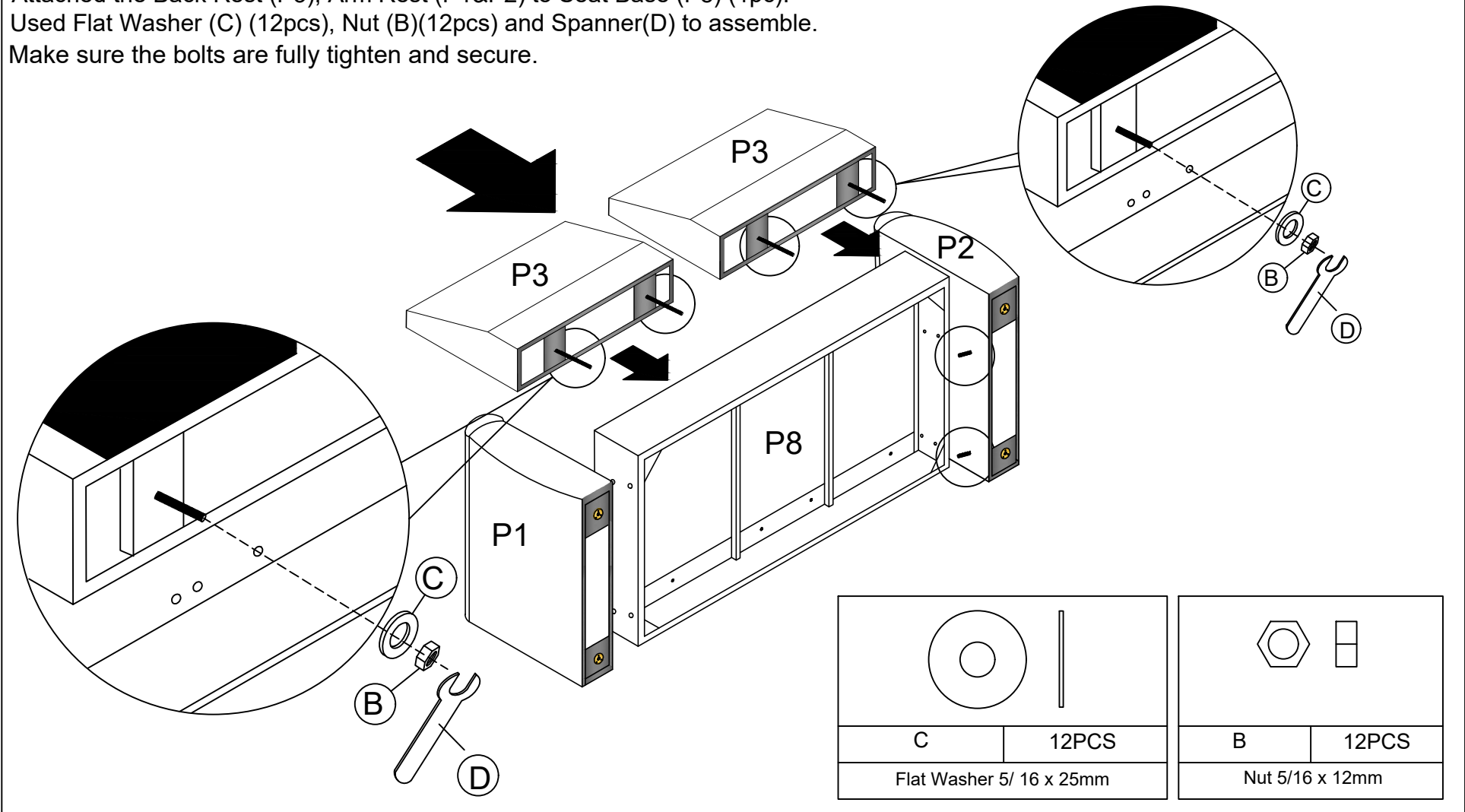

# ASSEMBLY INSTRUCTION

## STEP 6.

Closed cover cloth with velcro.

Attached Plastic Leg (P9) (4pcs) to Arm Rest (P1&P2) (2pcs). Legs should be tightened.

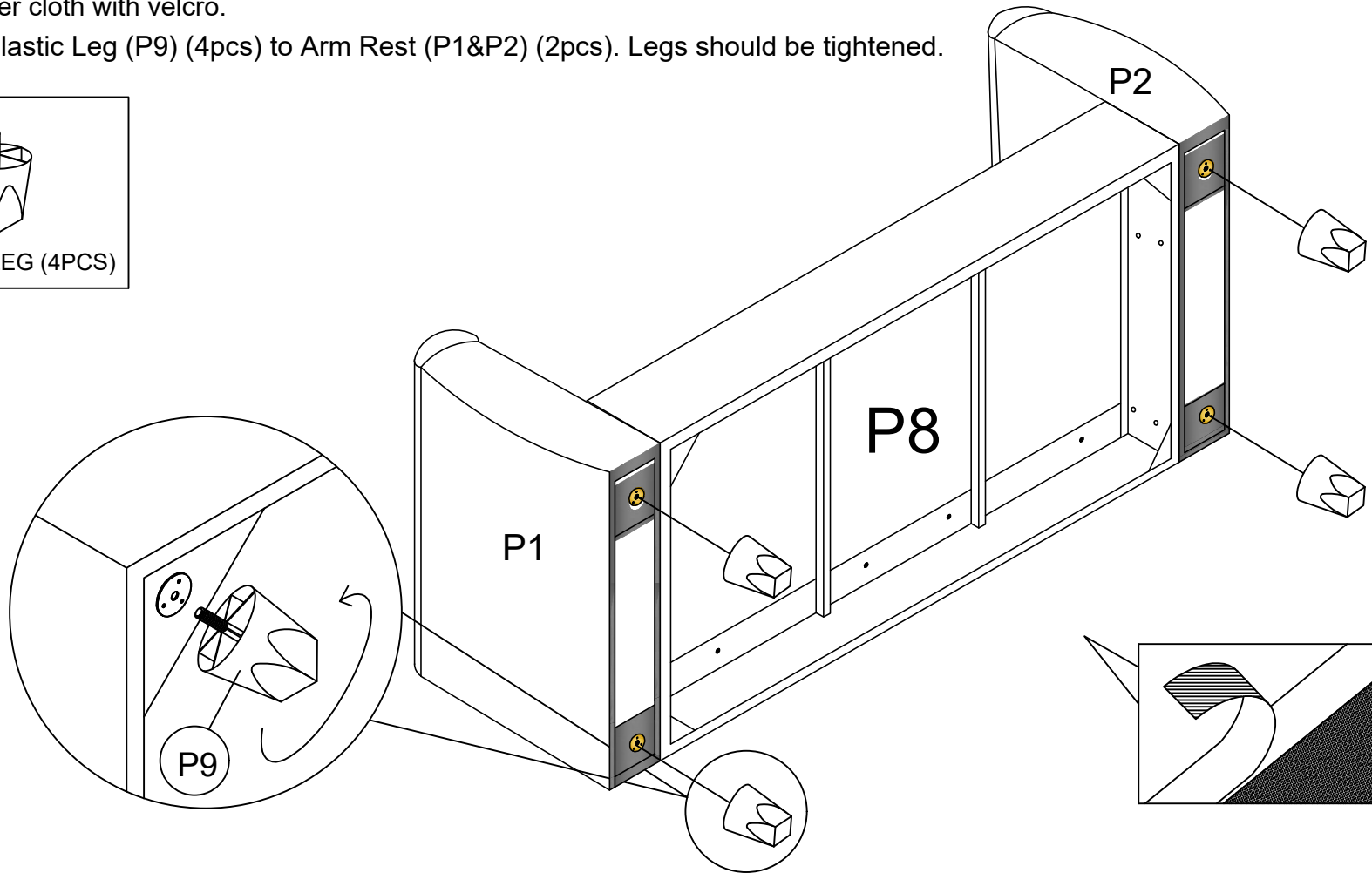
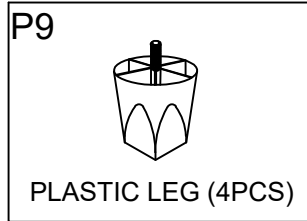

# ASSEMBLY INSTRUCTION

## STEP 7

Attach the Cushion Seat (P7) (3pcs), Back Cushion (P4,P5,P6) (3pcs) to the seat base.

