



ASSEMBLY INSTRUCTIONS

Thank you for purchasing this quality product . Be sure to check all packaging material carefully for small parts that may have come loose inside the carton during shipment .





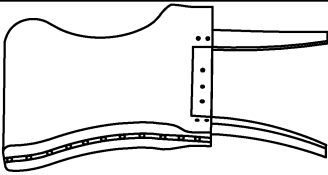
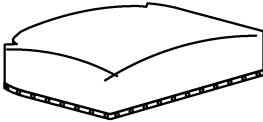

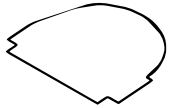
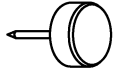
"Hardware is attached underneath the CUSHION SEAT"

This product will take 15-20 minutes to assemble.

Components List :

NO	DESCRIPTION	SKETCH	QTY
A	Back Rest		1pc
B	Cushion Seat		1pc
C	Front Legs		2pcs
D	Velcro		1pc
E	Plastic Glide		4pcs

Hardware List :

NO	DESCRIPTION	SIZE	SKETCH	QTY
1	Short Bolt	5/16" x42 mm		5pcs
2	Long Bolt	5/16" x57 mm		4pcs
3	Spring Washer	5/16" x Ø12		9pcs
4	Flat Washer	5/16" x Ø19		9pcs
5	Allen Key	58x23x4 mm		1pc
6	Wood Dowel	Ø10 x 30 mm		2pcs

Hammer may be require for assembly
Not included

Reminders

1. Use only the hardware supplied.
2. Once the chair is finished, level and tighten all the bolts.
3. Do not over-tighten bolts.
4. This item may require periodic tightening.

NOTE : Hardware Bag is located underneath the cushion seat (B)

NOTE :

1. Hardware pack is located underneath the Cushion Seat (B)
2. Two or more people are needed for assembly, Please keep all hardware parts out of the reach of children.

ASSEMBLY INSTRUCTIONS

Fig. 1

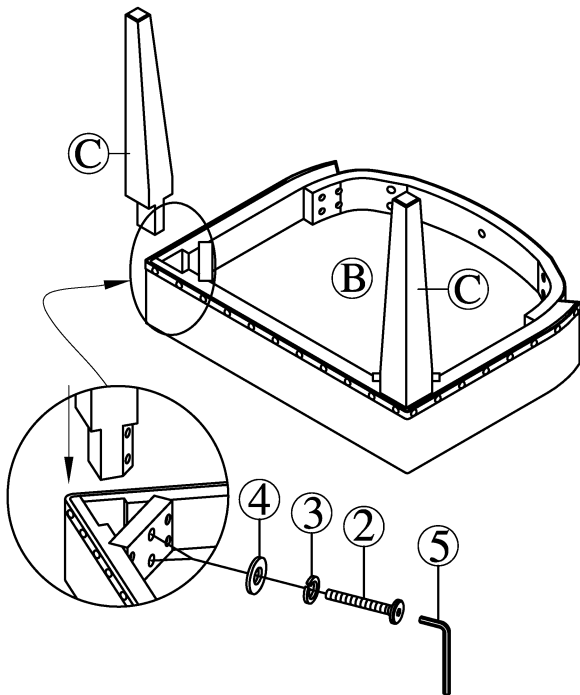

Grab Hardware Bag from underneath the Cushion Seat.
Do not fully tighten bolts until the product is level and the assembly of the product is completed.

Step 1. Remove Velcro (D) from underneath the Cushion Seat (B)
Insert Front Legs (C) into Cushion Seat (B)
and fasten with Long Bolt (2), Spring Washer (3),
Flat Washer (4) and tighten with Allen Key (5) as shown
in Fig. 1.

Do not fully tighten bolts

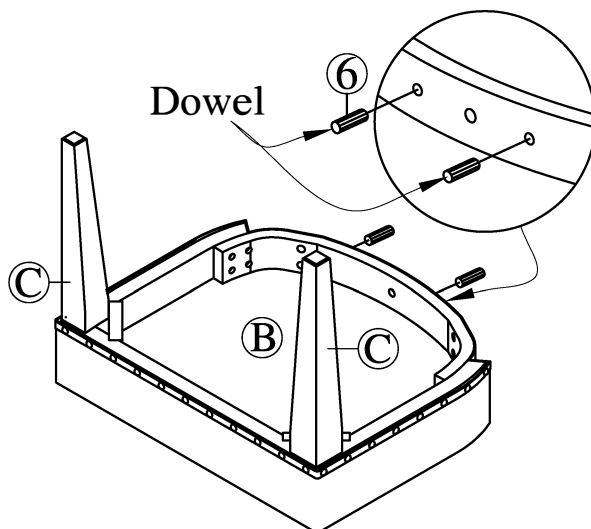

Fig. 2

Step 2. Insert Wood Dowels (6) to the back of
the Cushion Seat (B) as shown in Fig.2.
(Hammer may be required)

Do not fully tighten bolts

ASSEMBLY INSTRUCTIONS

Fig. 3

Step.3.1: Attach the Cushion Seat (B) to Backrest (A) by first inserting Wood Dowels (6) onto the Cushion Seat (B).

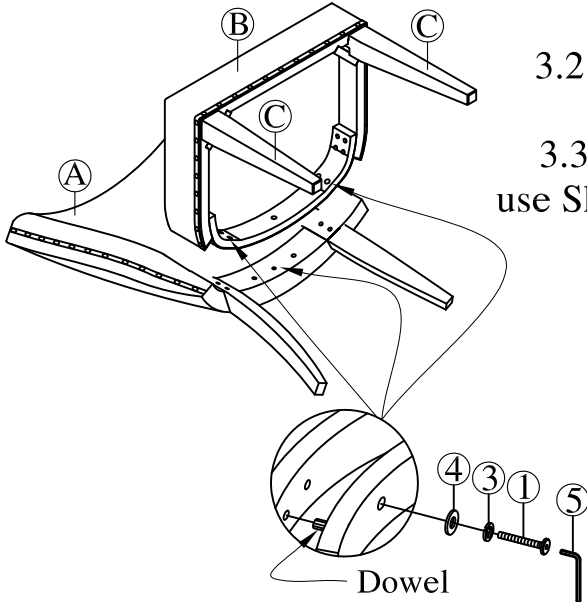

3.2: Insert Cushion Seat (B) into to Backrest (A)

3.3 To Secure Cushion Seat (B) to Backrest (A) use Short Bolt (1), Spring Washer (3), Flat Washer (4) and tighten with Allen Key (5) as shown in Fig.3 .

Fig. 4

Step 4. Place the loosely assembled chair on a hard flat surface and apply gentle downward pressure on the seat. As shown on Fig.4. Once the chair is balanced and leveled, fully tighten all bolts.

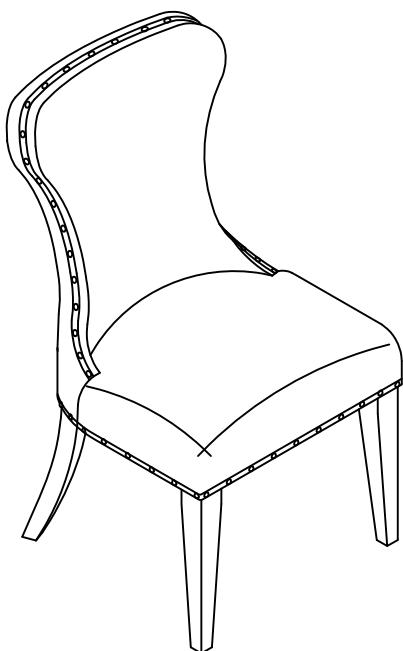
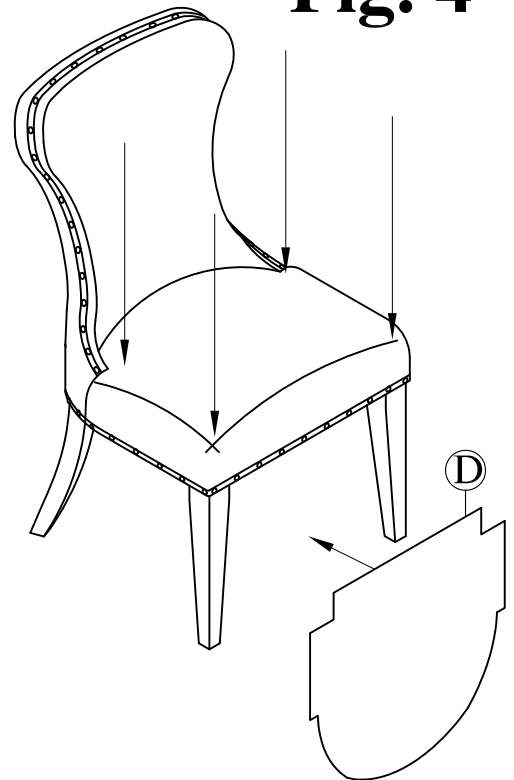

Step 5. Once all bolts have been tightened, attach Velcro (D) to underneath the Cushion Seat (B) as shown in Fig.4.

Assembly is now completed