

INVAL

Multi-Purpose Cabinet Gabinete Multiusos

REF.: GM 5940



SCAN THIS QR CODE
FOR ASSEMBLY TIPS

ESCAÑA EL CODIGO
QR Y ENCUENTRA EN
YOUTUBE VIDEOS CON
TIPS DE ARMADO

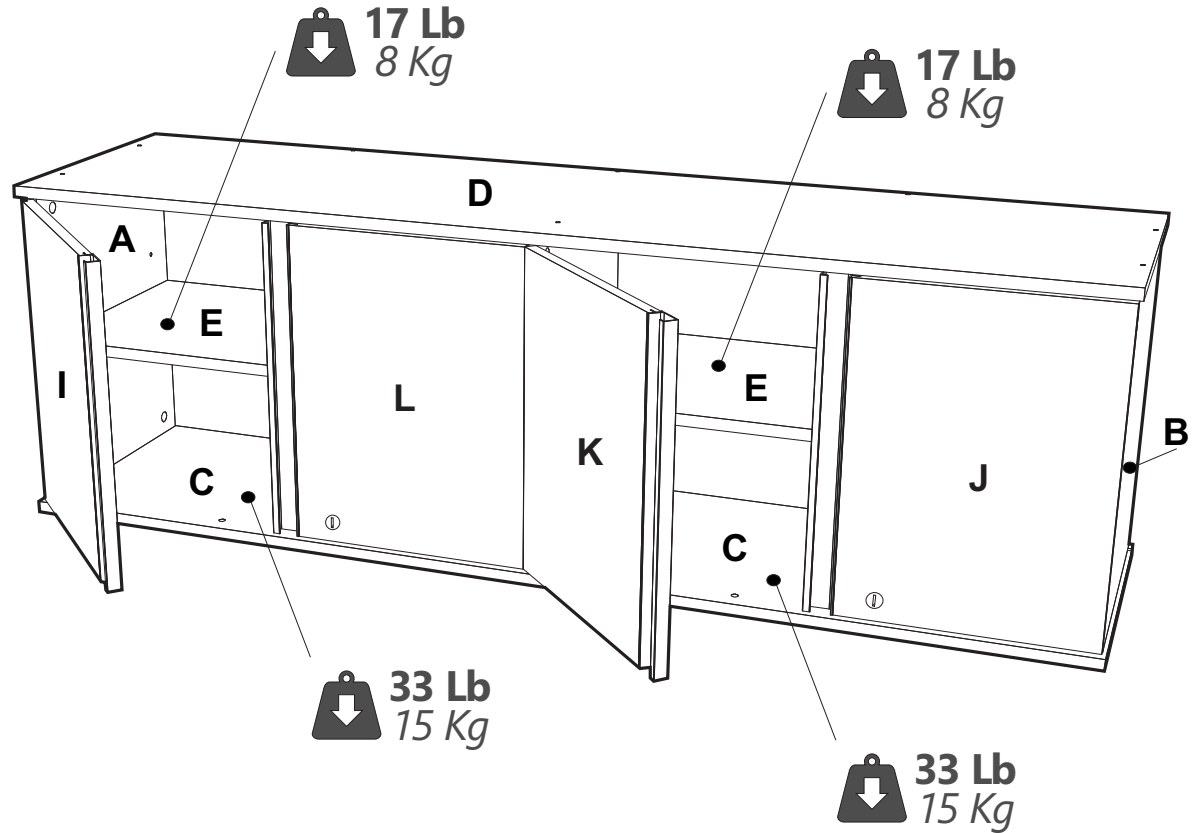

ATTENTION

When calling or writing us, please provide the OP number, here highlighted, so we can offer the most efficient response.

Al llamar o escribirnos, por favor darnos el número de OP, aquí resaltado, con el fin de ofrecerle la respuesta mas eficiente.

ATENCIÓN

OP:	
DATE/FECHA:	
FINISH/ACABADO:	

PLEASE DON'T RETURN THE FURNITURE TO THE STORE, CALL OR EMAIL US FIRST

POR FAVOR NO REGRESE EL MUEBLE A LA TIENDA, PRIMERO LLÁMENOS O ENVÍE UN EMAIL

WARNING - ADVERTENCIA

TWO PEOPLE ARE REQUIRED TO ASSEMBLE AND MOVE CORRECTLY THIS FURNITURE.
SE NECESITAN DOS PERSONAS PARA ARMAR Y DESPLAZAR CORRECTAMENTE ESTE MUEBLE.

1-888-659-3512 EXT 178
customerservice@invalamerica.com www.invalamerica.com



Certificado N° sc 640-1

**¡Gracias por la compra de un producto INVAL!
CERTIFICADO DE GARANTIA**

INVAL orgullosamente respalda los productos que fabricamos y por ello los garantizamos por un periodo de cinco (5) años después de la fecha de su compra. Para asistirle con mayor rapidez, por favor revise cuidadosamente todas las piezas y herrajes de este producto y así detectara faltantes, herrajes o piezas dañadas. Comuníquese de inmediato con nuestro Departamento de Servicio al Cliente o al Consumidor de acuerdo a nuestras líneas telefónicas y correo electrónico. Recibirá donde usted nos indique sin costo alguno las piezas o herrajes defectuosos o faltantes. Por favor tenga a mano el número del modelo o referencia, la Orden de Producción (OP) y la letra de la parte o pieza o el numero del herraje que usted necesita. Esta información la encontrará en el manual de instrucciones. También necesitara tener a mano la factura o recibo de compra. Esta garantía será aplicable solo cuando se le de uso normal a este mueble por parte del consumidor. Estos productos no han sido diseñados ni fabricados para ser usados a la intemperie, en condiciones climáticas extremas o estar expuestos a la humedad o al agua. La palabra "defectos" se define en esta garantía específicamente a imperfecciones que impidan el uso de este producto al consumidor. Esta garantía no cubre: 1) Defectos que hayan sido causados por un armado defectuoso o incorrecto, 2) Defectos que ocurran después que usted haya comprado el producto y le haga cualquier modificación, roturas intencionales, accidentes, sobrecarga, uso indebido, negligencia o que sean expuestos a la intemperie, humedad, al agua o a cualquier sustancia química. 3) Daños en su apariencia. 4) Movimientos o traslados inadecuados de un lugar a otro que afecten la funcionalidad del producto. 5) Exposición del mueble a ambientes húmedos o de baja ventilación, alta temperatura, suciedad o ha insectos como el comején, termita, hormiga blanca o cualquier otro tipo de insecto que afecte el producto. 6) El tablero melaminico no se desprende siempre en cuando cumpla estrictamente las recomendaciones de uso y cuidado informadas en esta garantía. 7) El mueble comprado armado no tiene garantía. Esta garantía se limita al remplazo de piezas o herrajes que presenten defectos o faltantes, bajo las condiciones indicadas, la asistencia técnica podrá tener un costo adicional en caso de no aplicar la garantía. La labor de ensamble no está incluida.

**Thank you for purchasing an INVAL product!
CERTIFICATE OF GUARANTEE**

INVAL proudly endorses the products we manufacture and therefore we guarantee them for a period of five (5) years after the date of purchase. To assist you more quickly, please carefully inspect all parts and hardware of this product for missing, hardware or damaged parts. Immediately contact our Customer or Consumer Service Department according to our phone lines and email. You will receive defective or missing parts or hardware where you indicate at no cost. Please have the model or reference number, the Production Order (OP) and the letter of the part or part or the number of the hardware you need. You will find this information in the instruction manual. You will also need to have your purchase invoice or receipt at hand. This guarantee will be applicable only when this furniture is used normally by the consumer. These products are not designed or manufactured to be used outdoors, in extreme weather conditions, or exposed to moisture or water. The word "defects" is defined in this warranty specifically to imperfections that prevent the use of this product by the consumer. This warranty does not cover: 1) Defects that have been caused by faulty or incorrect assembly, 2) Defects that occur after you have purchased the product and made any modification, intentional breakage, accident, overload, improper use, negligence or that are exposed to the weather, humidity, water or any chemical substance. 3) Damage to its appearance. 4) Inappropriate movements or transfers from one place to another that affect the functionality of the product. 5) Exposure of the furniture to humid environments or with low ventilation, high temperature, dirt or has insects such as termites, termites, white ant or any other type of insect that affects the product. 6) The melamine board does not come off as long as it strictly complies with the recommendations for use and care informed in this guarantee. 7) The furniture purchased assembled has no guarantee. This warranty is limited to the replacement of parts or hardware that are defective or missing, under the conditions indicated, technical assistance may have an additional cost if the warranty is not applied. Assembly labor is not included.

**¡Merci d'avoir acheté un produit INVAL!
CERTIFICAT DE GARANTIE**

INVAL approuve fièrement les produits que nous fabriquons et par conséquent nous les garantissons pour une période de cinq (5) ans après la date d'achat. Pour vous aider plus rapidement, veuillez inspecter soigneusement toutes les pièces et le matériel de ce produit pour détecter les pièces manquantes, le matériel ou les pièces endommagées. Contactez immédiatement notre service clientèle ou notre service clientèle selon nos lignes téléphoniques et nos e-mails. Vous recevrez gratuitement des pièces ou du matériel défectueux ou manquants sur votre indication. Veuillez avoir le numéro de modèle ou de référence, l'ordre de fabrication (OP) et la lettre de la pièce ou de la pièce ou le numéro du matériel dont vous avez besoin. Vous trouverez ces informations dans le manuel d'instructions. Vous devrez également avoir votre facture d'achat ou votre reçu à portée de main. Cette garantie ne sera applicable que lorsque ce meuble est utilisé normalement par le consommateur. Ces produits ne sont pas conçus ou fabriqués pour être utilisés à l'extérieur, dans des conditions météorologiques extrêmes ou exposés à l'humidité ou à l'eau. Le mot «défauts» est défini dans cette garantie spécifiquement aux imperfections qui empêchent l'utilisation de ce produit par le consommateur. Cette garantie ne couvre pas: 1) Les défauts qui ont été causés par un assemblage défectueux ou incorrect, 2) Les défauts survenant après avoir acheté le produit et effectué toute modification, casse intentionnelle, accident, surcharge, mauvaise utilisation, négligence ou que sont exposés aux intempéries, à l'humidité, à l'eau ou à toute substance chimique. 3) Dommages à son apparence. 4) Mouvements ou transferts inappropriés d'un endroit à un autre qui affectent la fonctionnalité du produit. 5) Exposition du meuble à des environnements humides ou à faible ventilation, des températures élevées, de la saleté ou des insectes tels que termites, termites, fourmis blanches ou tout autre type d'insecte qui affecte le produit. 6) Le panneau mélaminé ne se détache pas tant qu'il est strictement conforme aux recommandations d'utilisation et d'entretien informées dans cette garantie. 7) Les meubles achetés assemblés n'ont aucune garantie. Cette garantie est limitée au remplacement des pièces ou du matériel défectueux ou manquants, dans les conditions indiquées, l'assistance technique peut avoir un coût supplémentaire si la garantie n'est pas appliquée. Le travail de montage n'est pas inclus.

Condiciones y limitaciones de la Garantía

Warranty conditions and limitations
Conditions de garantie et limitations

Estabilidad de la madera	5 AÑOS
Wood stability	5 YEARS
Stabilité du bois	5 ANS
Humedad, hongo o deterioro por condiciones ambientales extremas	1 AÑO
Moisture, fungus, or deterioration from extreme environmental conditions	1 YEAR
Humidité, champignons ou détérioration due à des conditions environnementales extrêmes	1 AN
Recubrimiento de bordes en pvc	1 AÑO
Edge coating in pvc	1 YEAR
Hrevêtement de chant en pvc	1 AN
Herrajes móviles, de unión y de ensamble (Bisagras, rieles, cerraduras, etc.)	1 AÑO
Movable, joining and assembly hardware (Hinges, rails, locks, etc.)	1 YEAR
Quincaillerie mobile, d'assemblage et d'assemblage (charnières, rails, serrures, etc.)	1 AN
Sillas fijas y giratorias	1 AÑO
Fixed and rotating chairs	1 YEAR
Chaises fixes et rotatives	1 AN

Contacto



Contact
Contact

Para hacer efectiva su garantía, el consumidor deberá comunicarse con nuestro Servicio al Cliente a las siguientes líneas telefónicas, por la página Web o por correo electrónico, teniendo a la mano este Certificado de Garantía y la Factura de Compra del Producto, donde podrá indicar sus quejas, inquietudes, reclamos o sugerencias, que nos permita mejorar en nuestros productos y servicios.

To make their guarantee effective, the consumer must contact our Customer Service at the following telephone lines, through the website or by email, having this Guarantee Certificate and the Product Purchase Invoice at hand, where they can indicate their complaints, concerns, claims or suggestions that allow us to improve our products and services.

Pour rendre sa garantie effective, le consommateur doit contacter notre service clientèle aux lignes téléphoniques suivantes, via le site Web ou par courrier électronique, en ayant à portée de main ce certificat de garantie et la facture d'achat de produit, où il peut indiquer son plaintes, préoccupations, réclamations ou suggestions qui nous permettent d'améliorer nos produits et services.

Pais/Country/Pays	Teléfono/Telephone/Téléphones	Contacto/Contact/Contact
Colombia/Colombia/Colombie	1-8000-933-444	servicliente@inval.com.co
US - Canadá/EE.UU.-Canada/ Etats-Unis- Canada	1-888-659-3512 x 178 Fax 1-888-901-0088	customerservice@invalamerica.com
México/Mexico/Mexique	52 (55) 41 708 748	servicliente@inval.com.co
Otros Países/Other countries /Autres pays	 (57) 317 428 2761	servicliente@inval.com.co

MANUAL DEL BUEN USO DEL PRODUCTO	PRODUCT GOOD USE MANUAL	MANUEL D'UTILISATION DU PRODUIT
<p>Damos gracias por haber seleccionado nuestros productos y esperamos verlos favorecidos con sus futuras compras. Antes de empezar a armar este mueble, lea este instructivo, revise cuidadosamente las piezas y herrajes y realice el inventario para identificar que todo esté completo y en buen estado.</p> <p> En caso de que le haga falta alguna pieza o herraje, no devuelva el producto a la tienda, por favor llame a la línea de servicio al cliente o al consumidor de INVAL o escribanos vía página web o por correo electrónico. Acuda a la línea de Servicio al Cliente INVAL cuando lo crea necesario para aclarar dudas sobre el mueble.</p>	<p>In the event that you are missing any parts or hardware, do not return the product to the store, please call INVAL's customer or consumer service line or write to us via the website or by email. Go to the INVAL Customer Service line when you think it is necessary to clarify doubts about the furniture.</p> <p> In the event that you are missing any parts or hardware, do not return the product to the store, please call INVAL's customer or consumer service line or write to us via the website or by email. Go to the INVAL Customer Service line when you think it is necessary to clarify doubts about the furniture.</p>	<p>Nous sommes reconnaissants d'avoir sélectionné nos produits et espérons être favorisés lors de vos futurs achats. Avant de commencer à assembler ce meuble, lisez ce manuel d'instructions, examinez attentivement les pièces et la quincaillerie et faites l'inventaire pour vous assurer que tout est complet et en bon état.</p> <p> Dans le cas où il vous manque des pièces ou du matériel, ne renvoyez pas le produit au magasin, veuillez appeler la ligne de service client ou consommateur d'INVAL ou nous écrire via le site Web ou par courrier électronique. Rendez-vous sur la ligne Service Client INVAL lorsque vous pensez qu'il est nécessaire de clarifier les doutes sur le mobilier.</p>



Lea y siga detenidamente el orden consecutivo de las instrucciones de armado.
Read and carefully follow the sequential order of the assembly instructions.
Lisez et suivez attentivement l'ordre séquentiel des instructions d'assemblage.



Se requiere de dos personas para armar y mover este mueble.
It takes two people to assemble and move this furniture.
Il faut deux personnes pour assembler et déplacer ce meuble.



Arme el mueble en una superficie limpia, si desea puede usar el empaque como protector para evitar que el mueble se raye con el piso.
Assemble the furniture on a clean surface, if you wish you can use the packaging as a protector to prevent the furniture from being scratched by the floor.
Assemblez le meuble sur une surface propre, si vous le souhaitez, vous pouvez utiliser l'emballage comme protecteur pour éviter que le meuble ne soit rayé par le sol.



Durante el armado no golpee ni martille el producto, hágalo solo donde se indica.
During assembly do not strike or hammer the product, do so only where indicated.
Lors de l'assemblage, ne pas frapper ni marteler le produit, ne le faites que là où cela est indiqué.



Ensamble y ubique el mueble sobre una superficie plana y nivelada; para asegurar su correcto funcionamiento y evitar su deterioro.
Assemble and place the furniture on a flat and level surface; to ensure its proper functioning and prevent deterioration.
Assemblez et placez les meubles sur une surface plane et de niveau; pour garantir son bon fonctionnement et éviter sa détérioration.



No pinte el mueble.
Do not paint the furniture.
Ne peignez pas les meubles.



Limpie el mueble periódicamente con su producto limpiador favorito, evite usar sustancias químicas, abrasivas o agua en exceso. En caso de que el mueble se moje, séquelo inmediatamente con un trapo seco absorbente.
Clean the furniture periodically with your favorite cleaning product, avoid using chemicals, abrasives or excess water. In case the furniture gets wet, wipe it dry immediately with a dry absorbent cloth.
Nettoyez régulièrement les meubles avec votre produit de nettoyage préféré, évitez d'utiliser des produits chimiques, des abrasifs ou un excès d'eau. Si le meuble est mouillé, essuyez-le immédiatement avec un chiffon absorbant sec.



Evite que los menores se suban al mueble.
Prevent minors from climbing onto the furniture.
Empêchez les mineurs de grimper sur les meubles.



Proteja el mueble del agua y de la humedad.
Protect the furniture from water and humidity.
Protégez les meubles de l'eau et de l'humidité.



Evite la exposición del mueble a ambientes húmedos o de baja ventilación, alta temperatura, suciedad o ha insectos como la termita, hormiga blanca o cualquier otro tipo de insecto que afecte el producto.
Avoid exposing the furniture to humid or low ventilation environments, high temperatures, dirt or insects such as termites, white ant or any other type of insect that affects the product.
Évitez d'exposer les meubles à des environnements humides ou à faible ventilation, à des températures élevées, à de la saleté ou à des insectes tels que termites, fourmis blanches ou tout autre type d'insecte qui affecte le produit.



No use el mueble al aire libre. Evite colocar objetos calientes sobre las superficies del mueble.
Do not use the furniture outdoors. Avoid placing hot objects on furniture surfaces.
N'utilisez pas les meubles à l'extérieur. Évitez de placer des objets chauds sur les surfaces des meubles.

Required Tools

Herramientas Requeridas
Outils Nécessaires

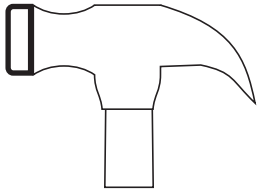

Hammer
Martillo
Marteau

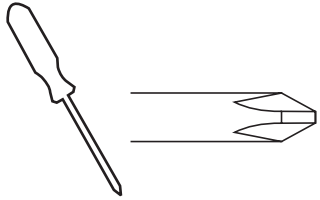

Philips Screwdriver
Atornillador Estrella
Tournevis Cruciforme

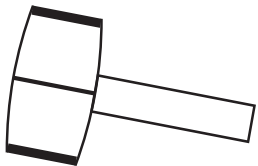

Rubber Hammer
Martillo De goma
Marteau en Caoutchouc

Cam Lock
Tuerca

Largest hole
Perforación amplia
Plus grand trou

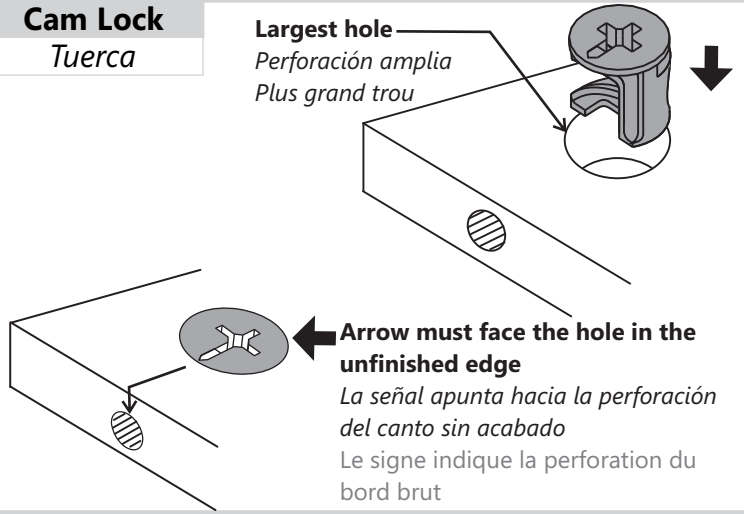

Arrow must face the hole in the unfinished edge
La señal apunta hacia la perforación del canto sin acabado
Le signe indique la perforation du bord brut

Cam Stud
Perno

Do NOT insert the cam studs in the edge holes
NO INSERTE pernos en las perforaciones de los cantos
NE PAS INSÉRER de boulons dans les bords

Insert only in face hole
Inserte unicamente en las perforaciones indicadas
Insérer uniquement dans les trous indiqués

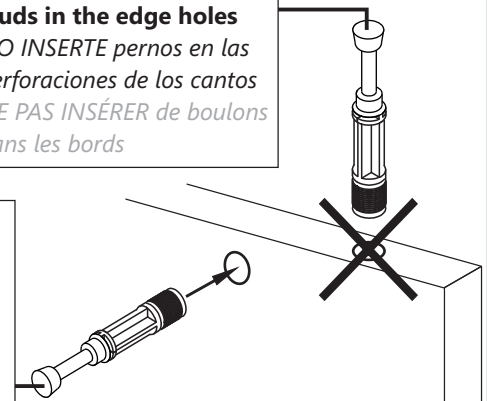

Wooden Dowels
Tarugo de madera

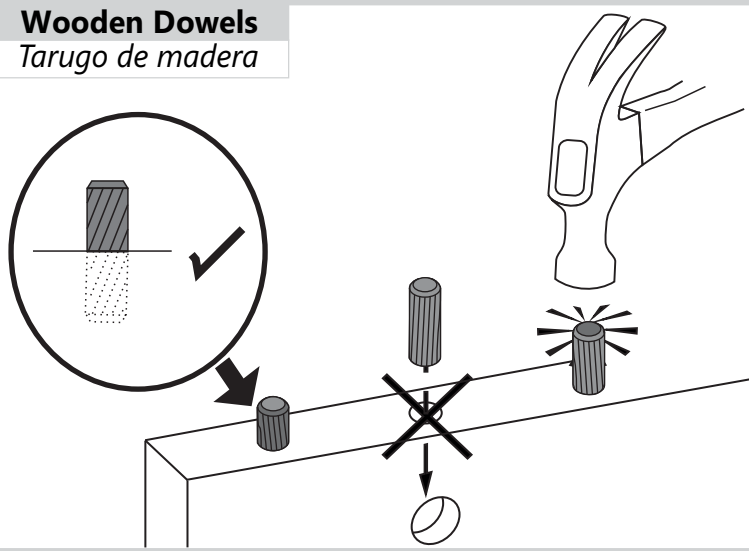

Locking Twist
Giro de bloqueo

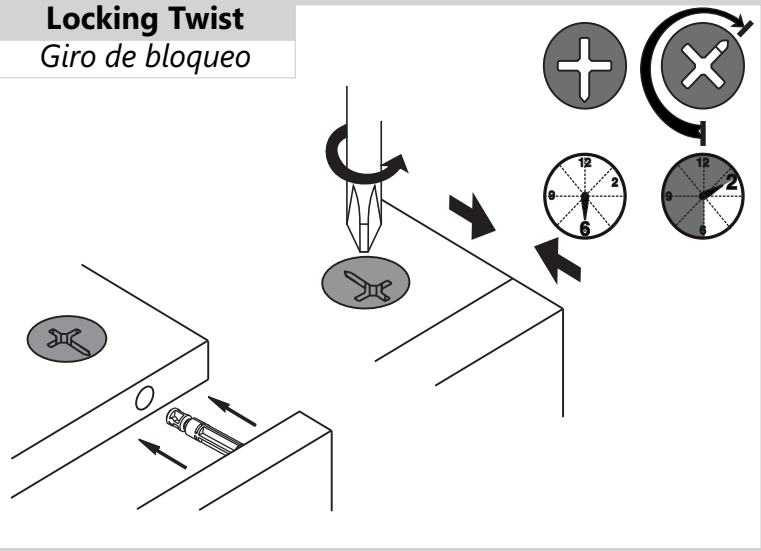

(ES) El ensamble adecuado de este herraje garantiza su durabilidad (EN) Adequate assembly of this fitting guarantee item sturdiness (FR) Un bon assemblage de ce matériel garantit sa durabilité

(EN) IMPORTANT Illustrations depicted in this manual are representative of the assembly process. For this reason, physical fittings can change and not be identical of the ones shown in the illustrations. INVAL S.A. keeps the rights of making changes with no previous advice. (ES) IMPORTANTE Las Imágenes e ilustraciones de los herrajes en este manual son representativos para guiar al usuario durante el proceso de armado, por lo anterior el herraje físico no debe ser necesariamente igual a la ilustración. INVAL S.A. se reserva el derecho de hacer cambios sin previo aviso. (FR) IMPORTANT Les images et illustrations du matériel dans ce manuel sont représentatives pour guider l'utilisateur pendant le processus d'assemblage, par conséquent le matériel physique ne doit pas nécessairement être le même que l'illustration. INVAL S.A. se réserve le droit d'apporter des modifications sans préavis.

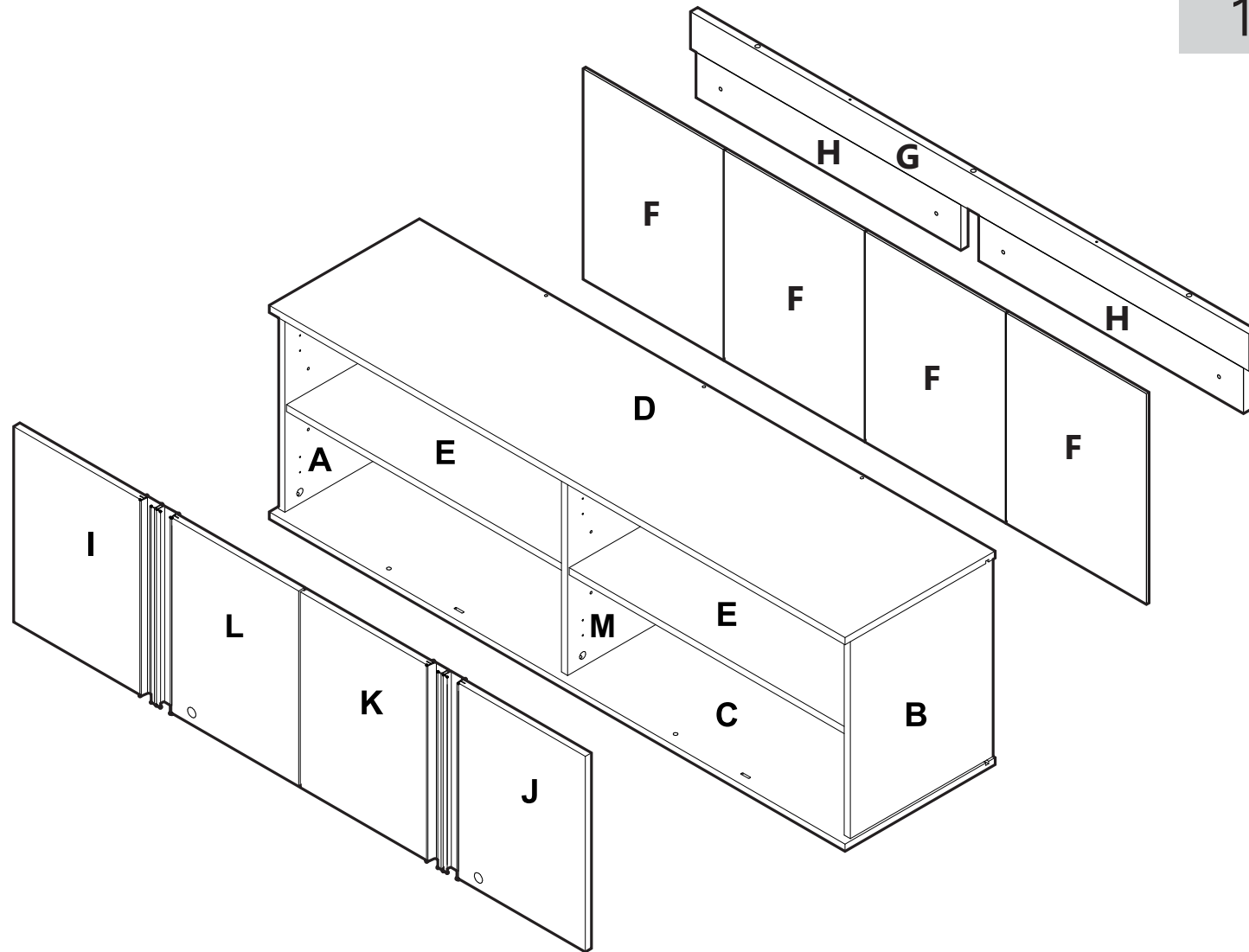

TOTAL
18

Part Pieza	Quantity Cantidad
A	1
B	1
C	1
D	1
E	2
F	4
G	1
H	2
I	1
J	1
K	1
L	1
M	1

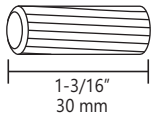
	X 10
1 WOODEN DOWELS TARUGOS DE MADERA	

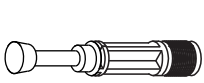
	X 8
2 CAM STUDS PERNOS	

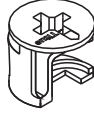
	X 8
3 CAM LOCKS TUERCAS	

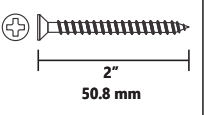
	X 10
4 BLACK SCREW TORNILLO NEGRO	

	X 8
5 PANEL SUPPORT SOPORTE ENTREPAÑO	

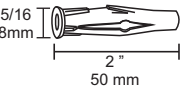
	X 6
6 WALL ANCHOR CHAZO ANCLA	

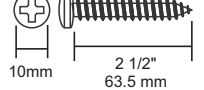
	X 6
7 WALL SCREW TORNILLO A PARED	

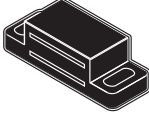
	X 2
8 MAGNETIC LOCK CIERRE MAGNÉTICO	

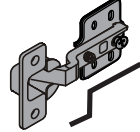
	X 4
9a DOOR HINGE BISAGRA PUERTA	

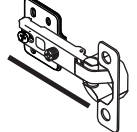
	X 4
9b DOOR HINGE BISAGRA PUERTA	

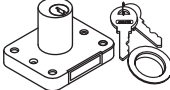
	X 2
10 LOCK CERRADURA	

	X 2
11 COTTER PASADOR	

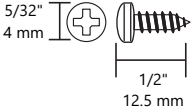
	X 4
12 MAGNETIC LOCK-SCREW TORNILLO-CIERRE IMÁN	

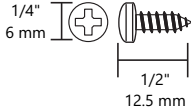
	X 42
13 HINGES-SCREWS TORNILLO-BISAGRAS	

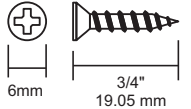
	X 8
14 LOCK SCREW TORNILLO CERRADURA	

	X 6
15 CAM CAPS TAPA TUERCAS	

	X 2
16 ANGLE BRACKET ÁNGULO METALICO	

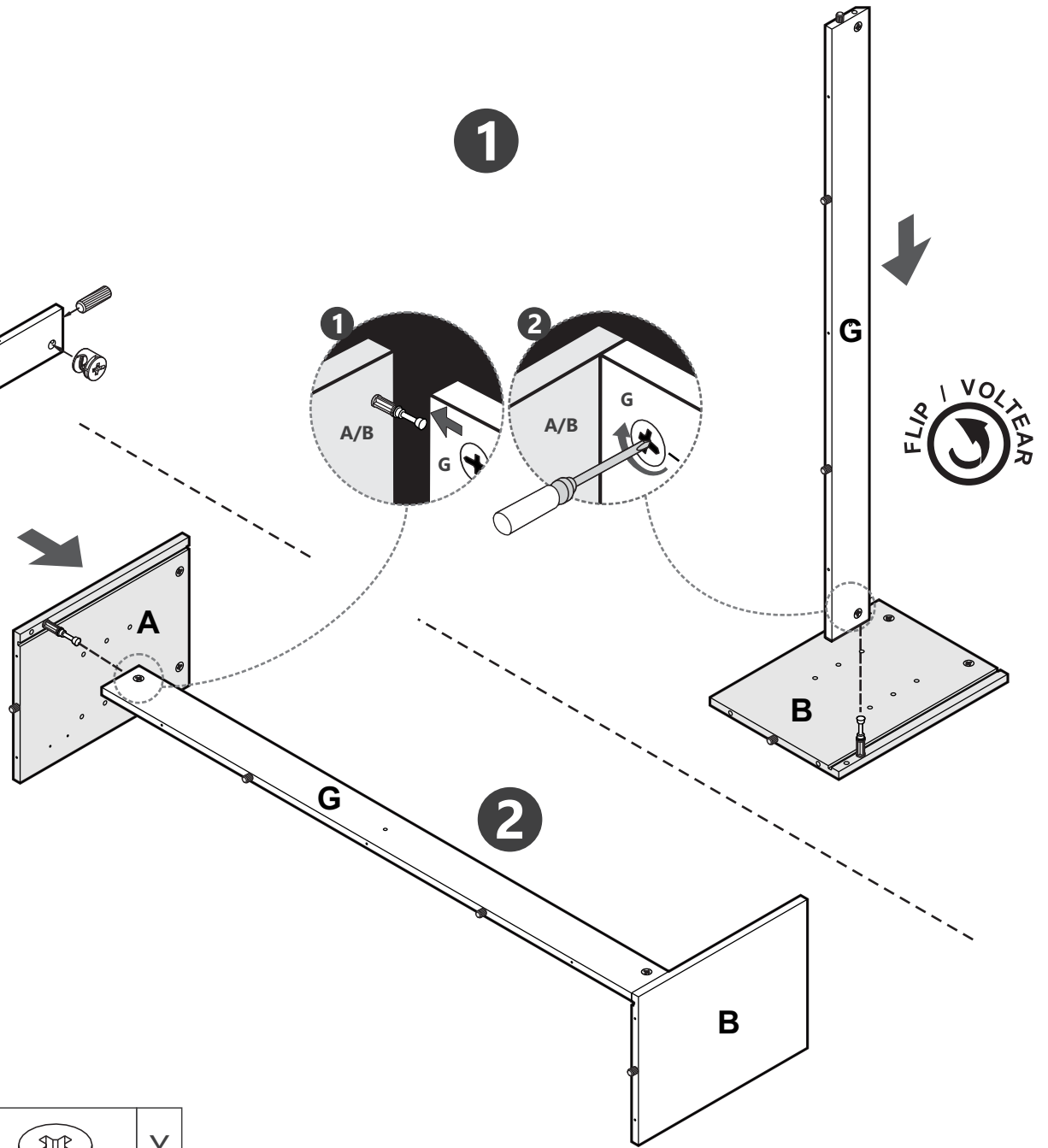
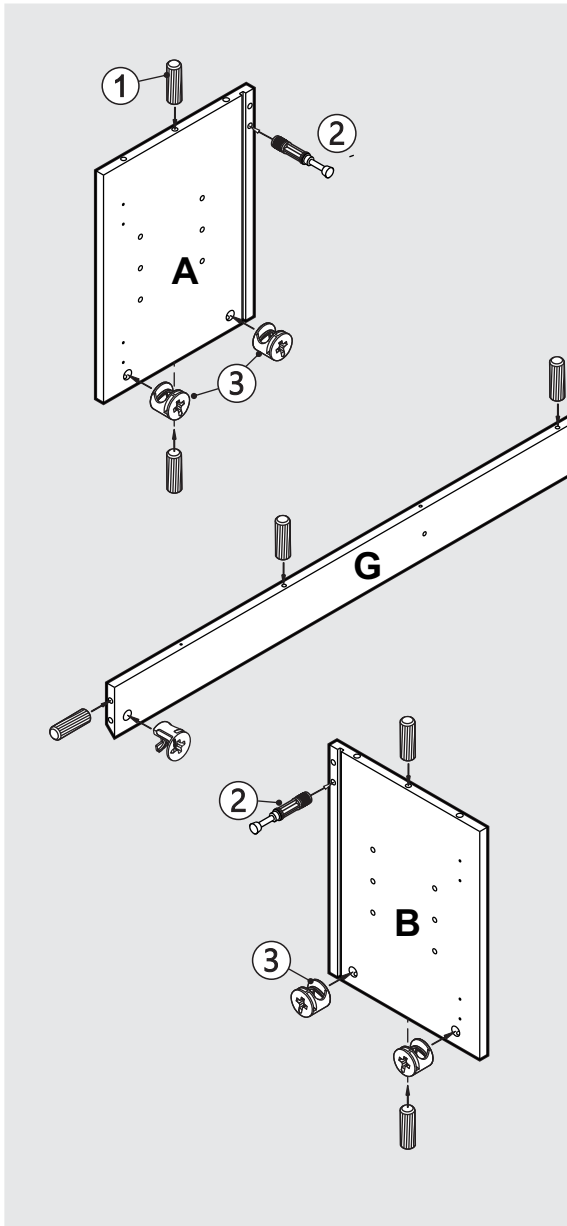

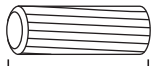
	X 8
1-3/16" 30 mm	
1 WOODEN DOWELS TARUGOS DE MADERA	

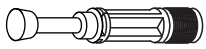
	X 2
2 CAM STUDS PERNOS	

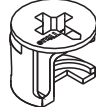
	X 6
3 CAM LOCKS TUERCAS	

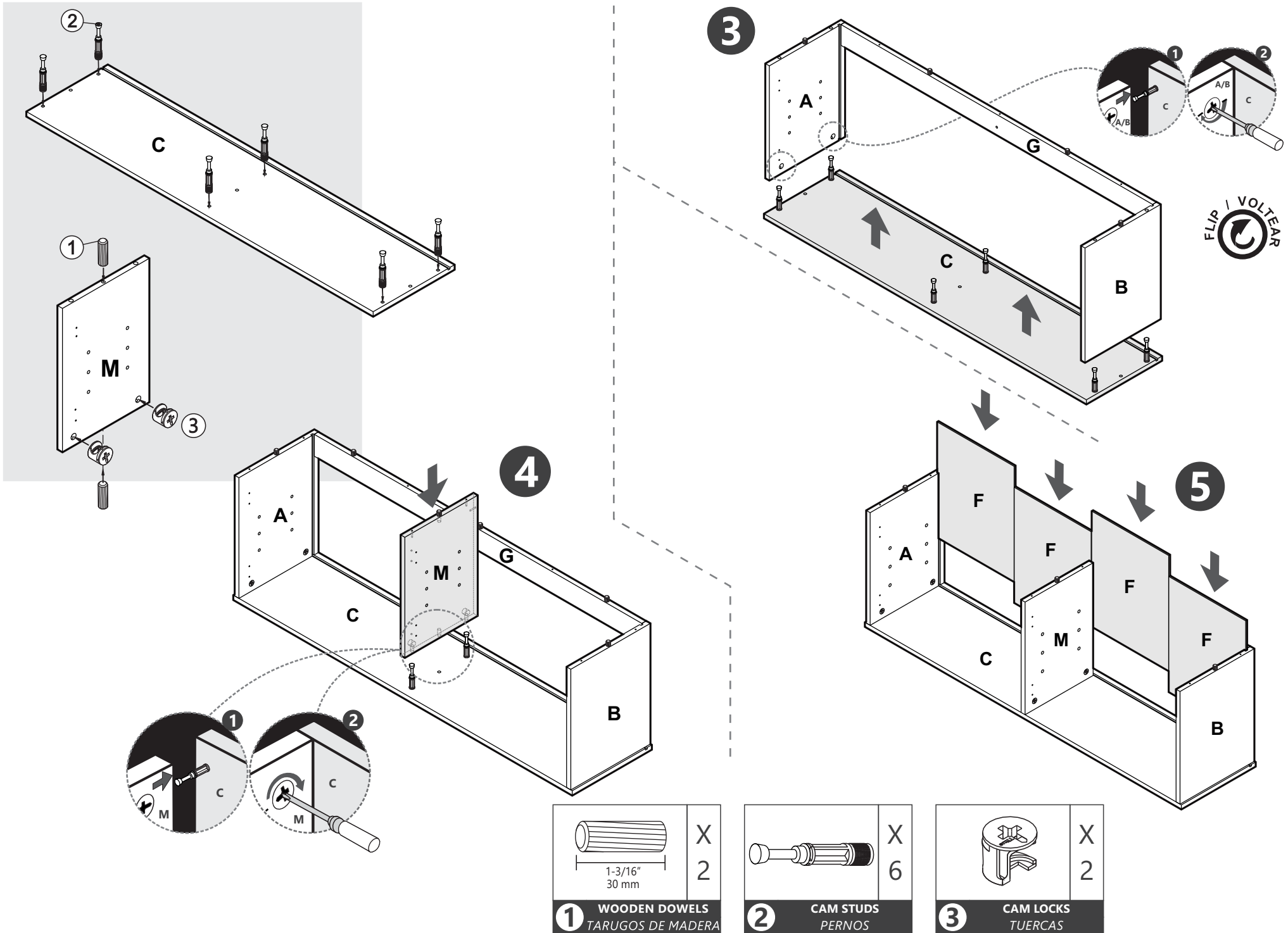

	X 2
1-3/16" 30 mm	
1	WOODEN DOWELS TARUGOS DE MADERA

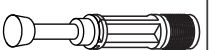
	X 6
2	CAM STUDS PERNOS

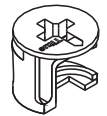
	X 2
3	CAM LOCKS TUERCAS

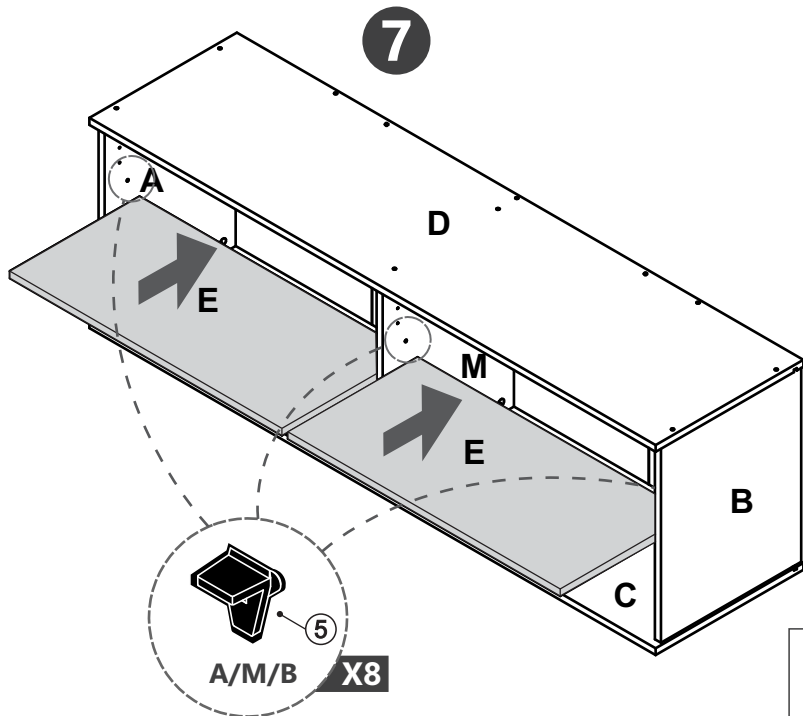
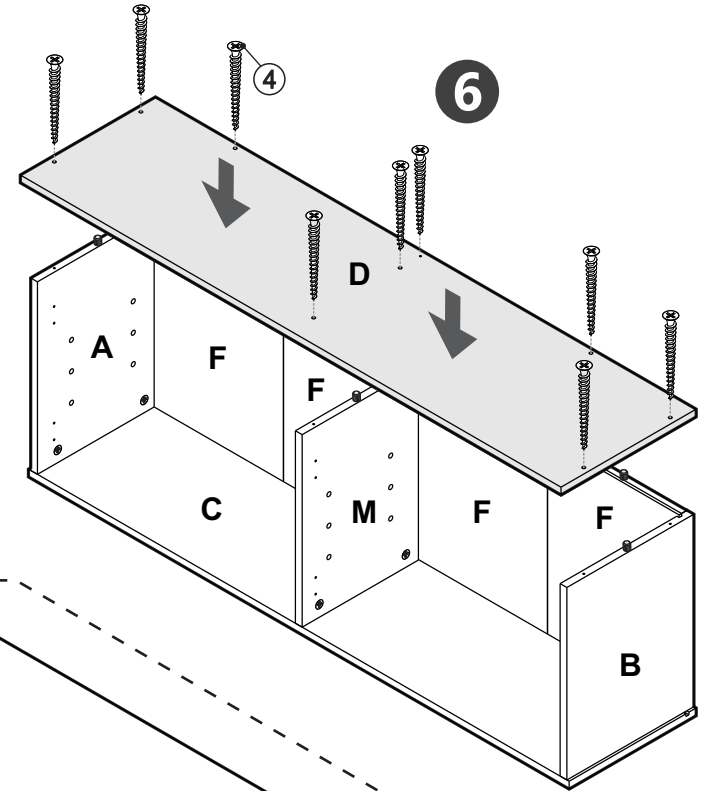
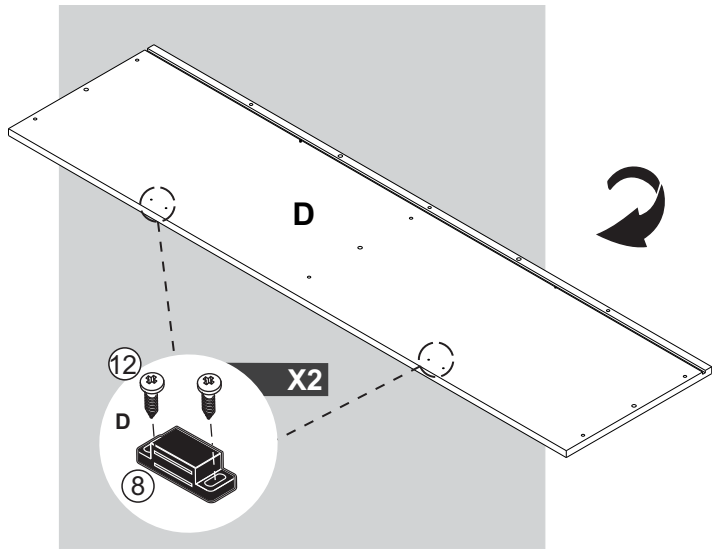

8

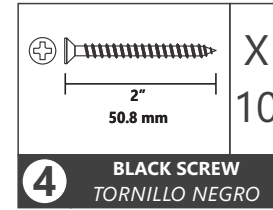
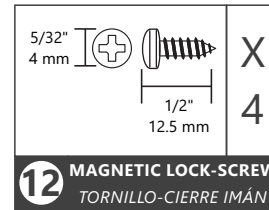
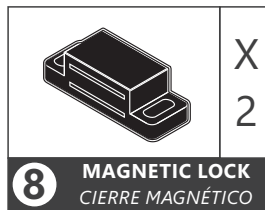
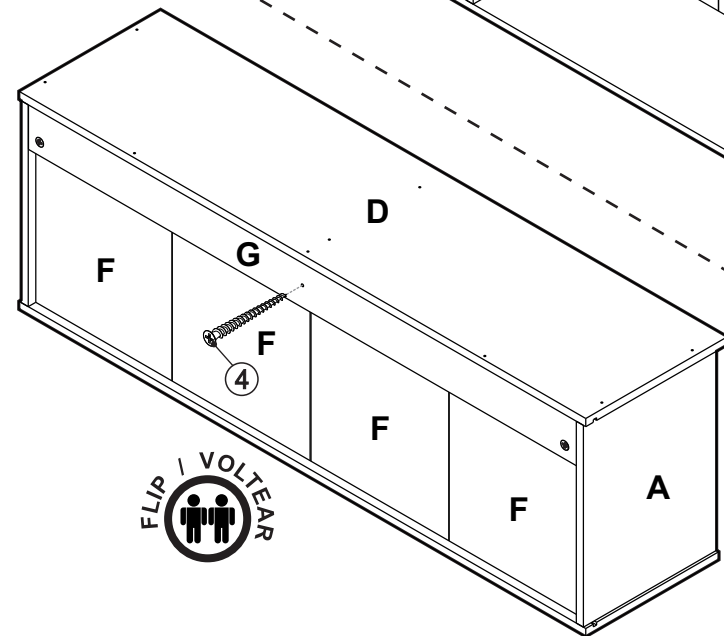

Loosen or tighten the indicated screw to **ADJUST HEIGHT.**

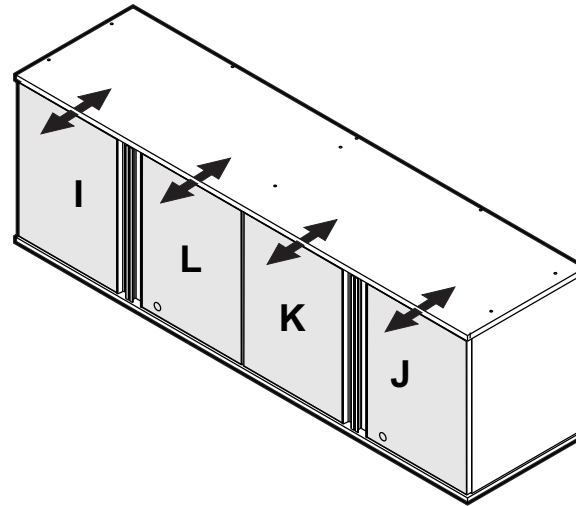
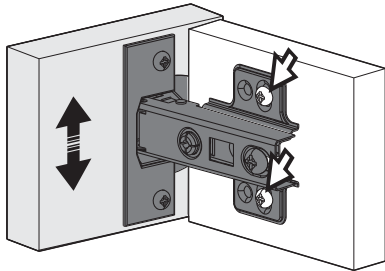

Loosen or tighten the indicated screw to adjust **SIDE AND GAPS ADJUSTMENT.**

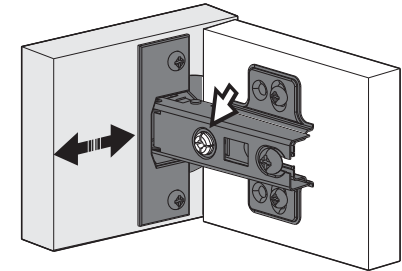

Loosen or tighten the indicated screw to **ADJUST DEPTH.**

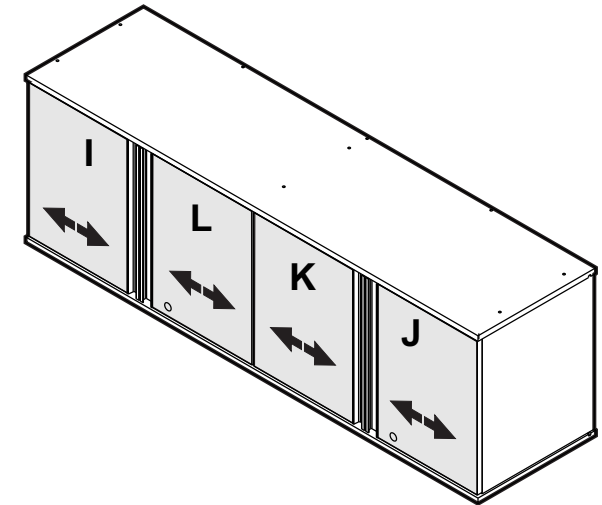
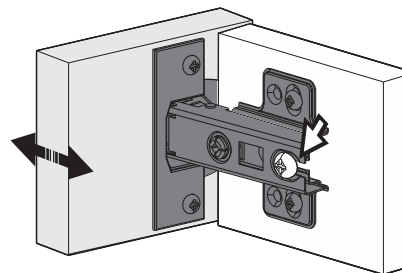
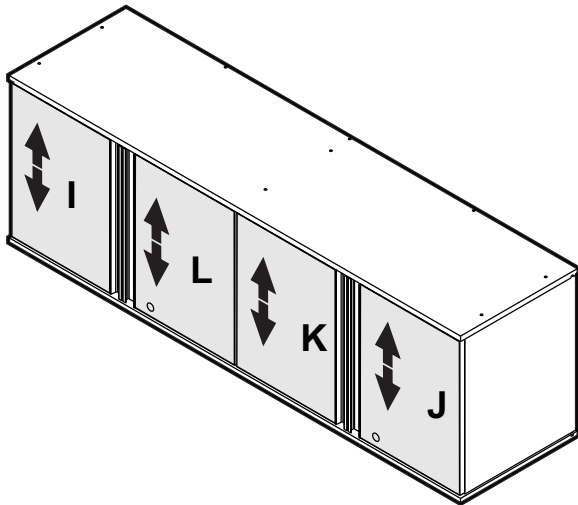

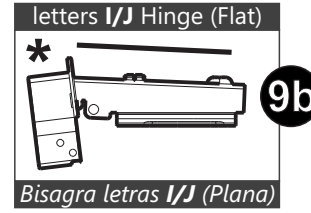
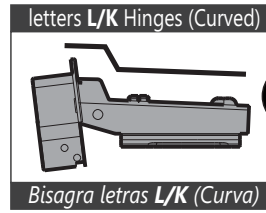
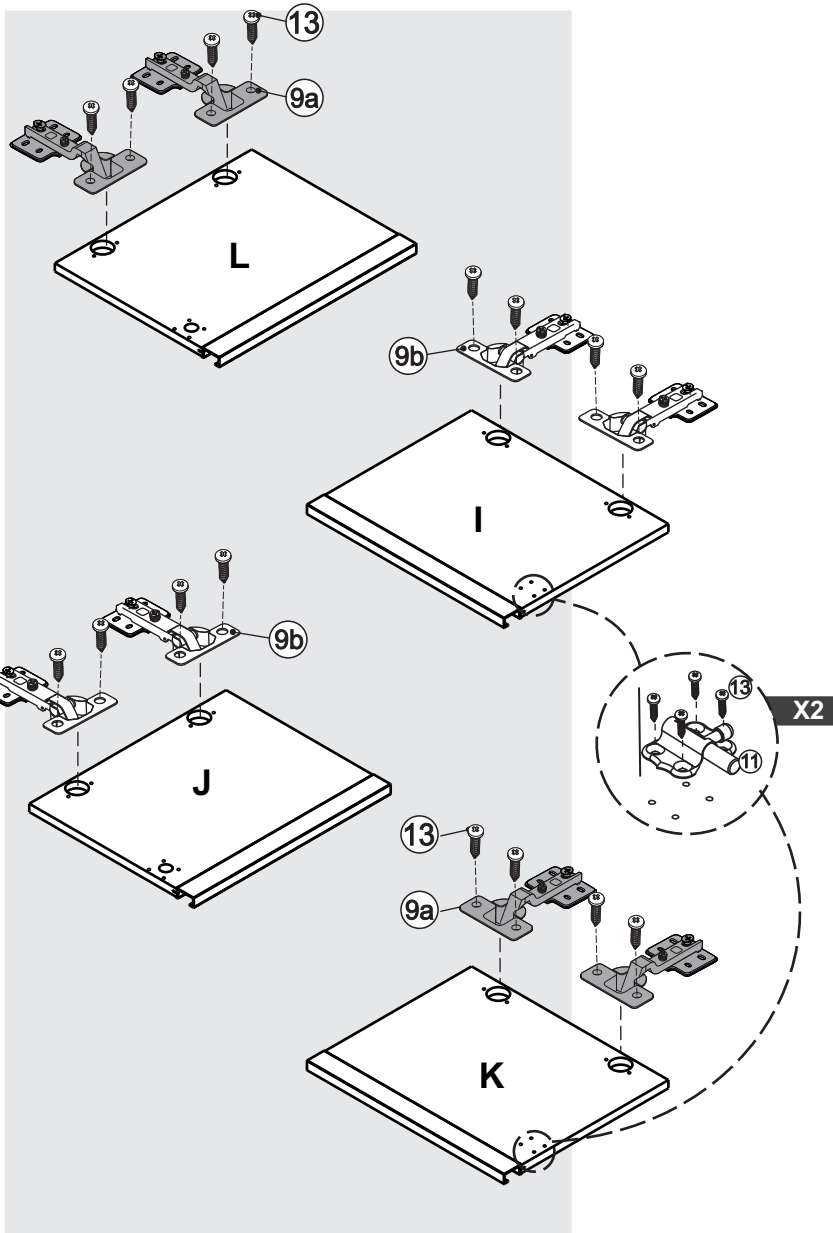

Hinges Assembly



Armado de Bisagras

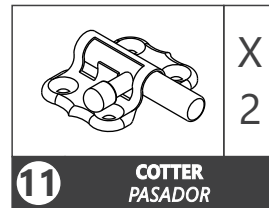
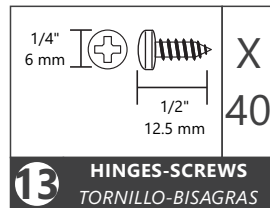
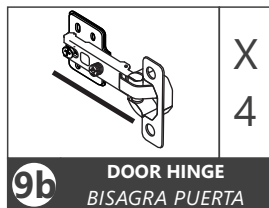
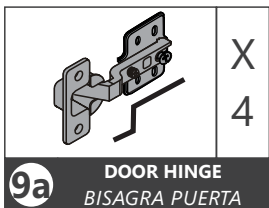
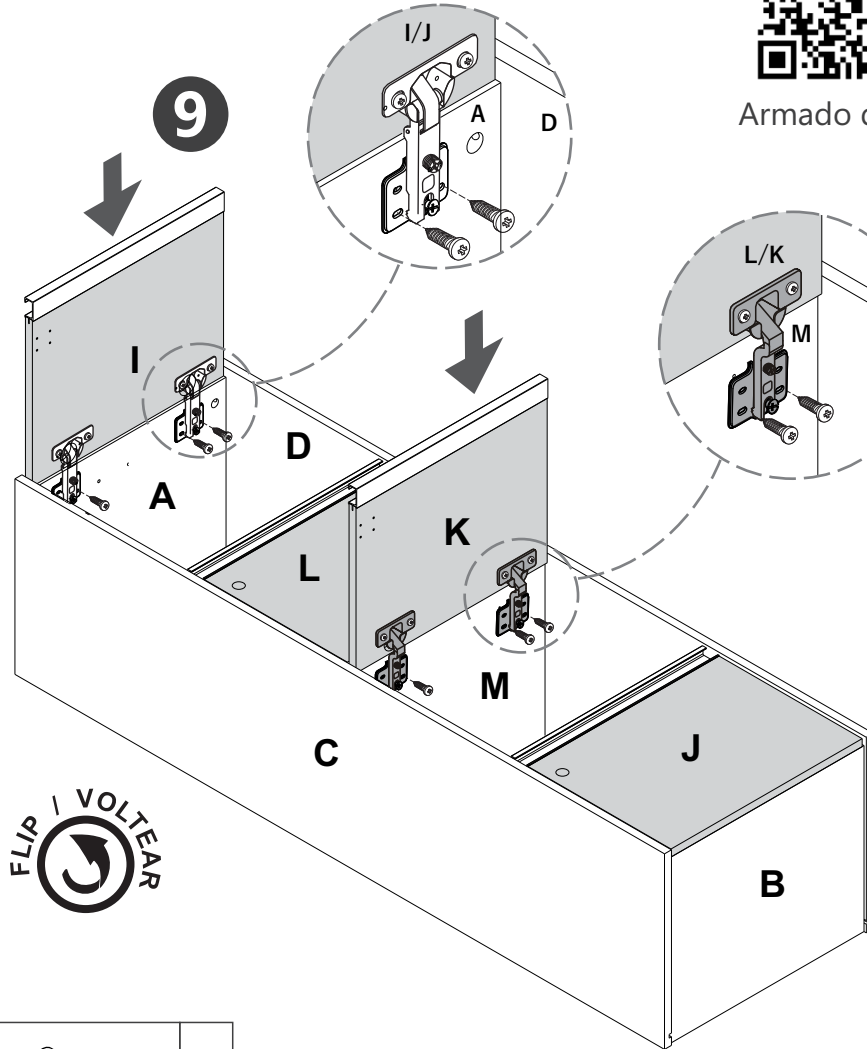

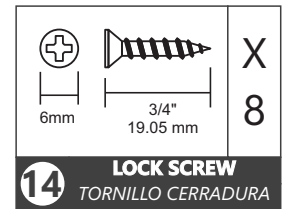
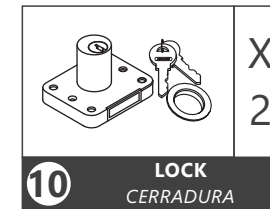
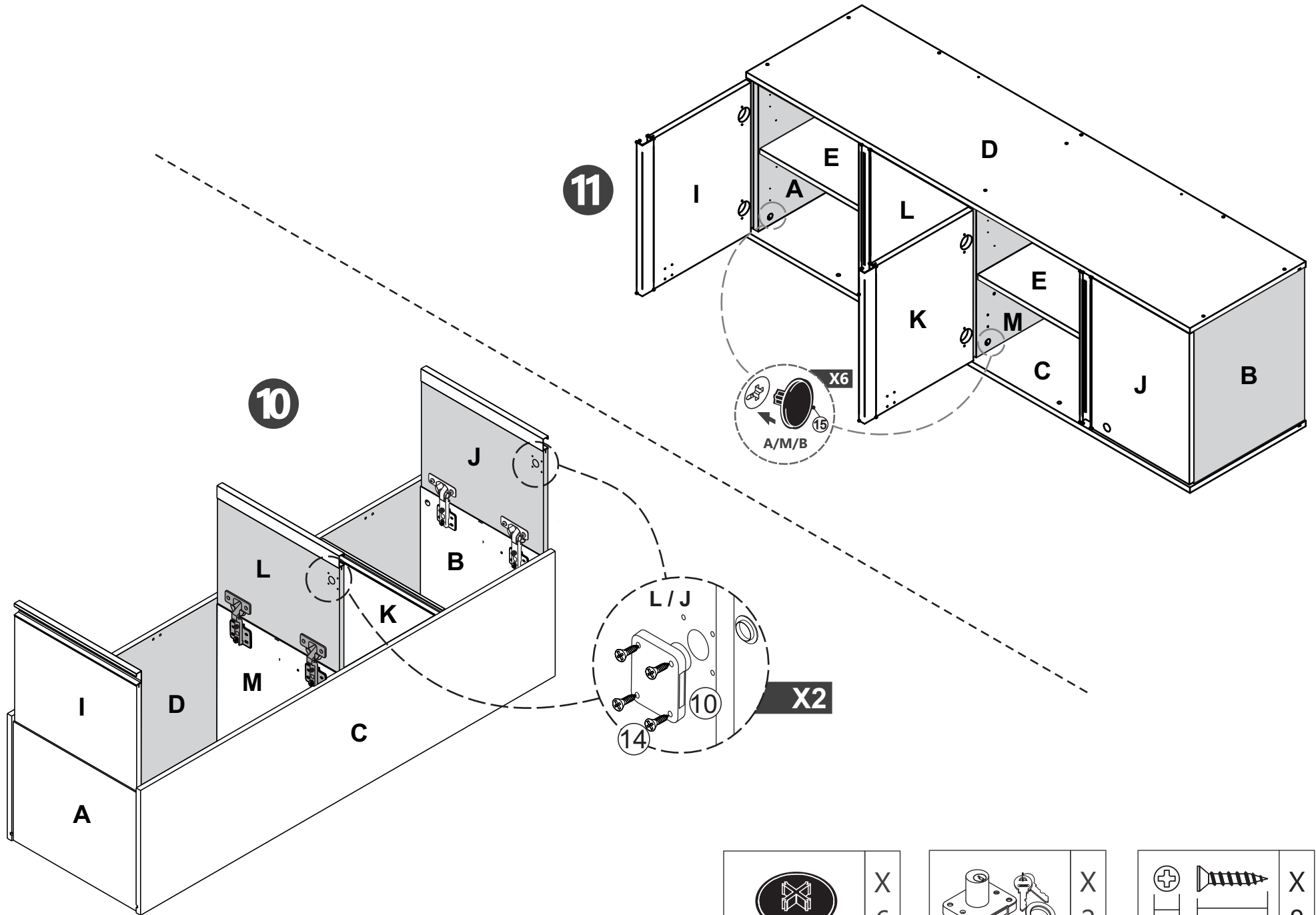

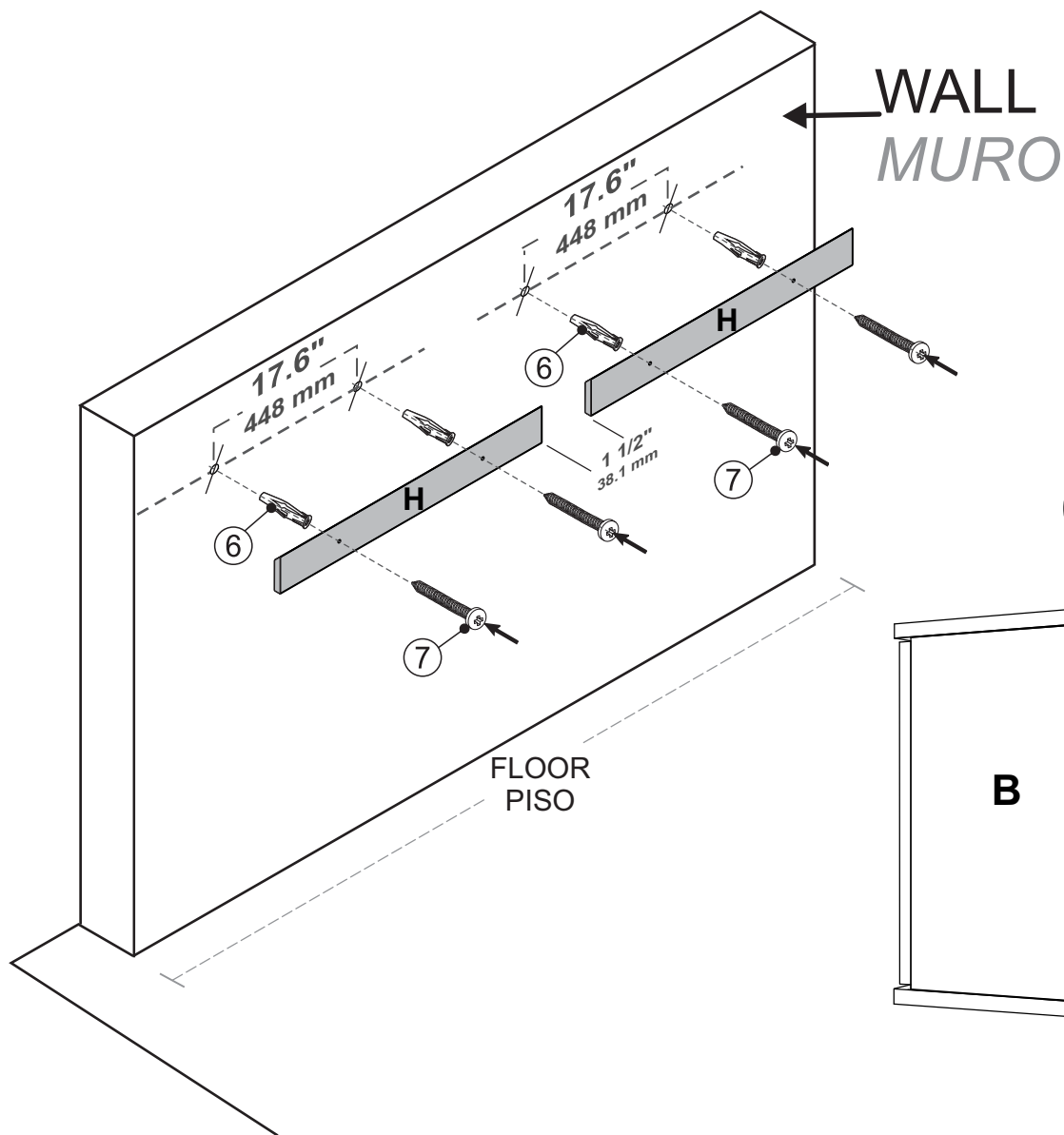

12

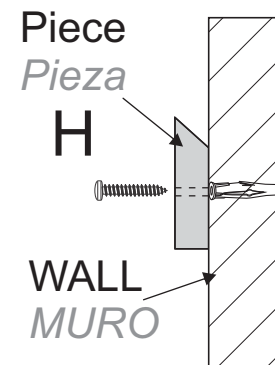
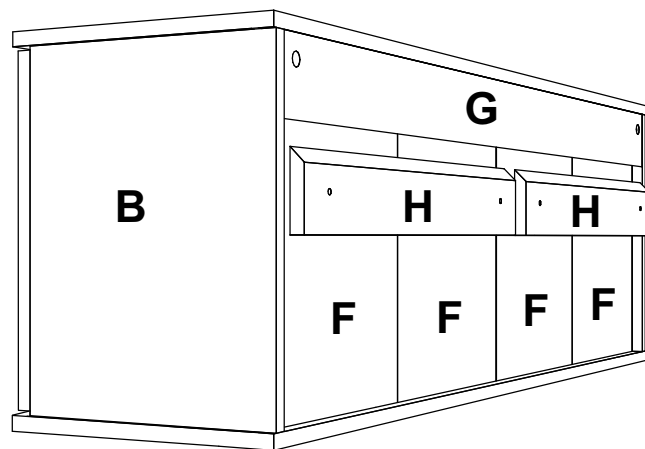

ANCHOR/ CHAZO

To use this type of anchor, the walls must be made of solid concrete and brick. If doubt, contact your nearest hardware store.

Para el uso de estos chazos de anclaje, las paredes deben ser solidas, de cemento y ladrillo. Si no, contáctese con su ferreteria más cercana.

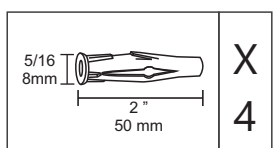

6 WALL ANCHOR
CHAZO ANCLA

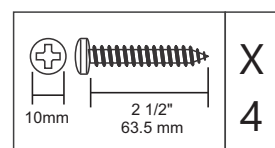

7 WALL SCREW
TORNILLO A PARED

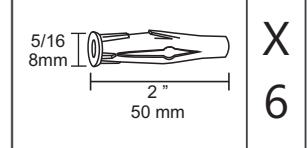

6 WALL ANCHOR
CHAZO ANCLA



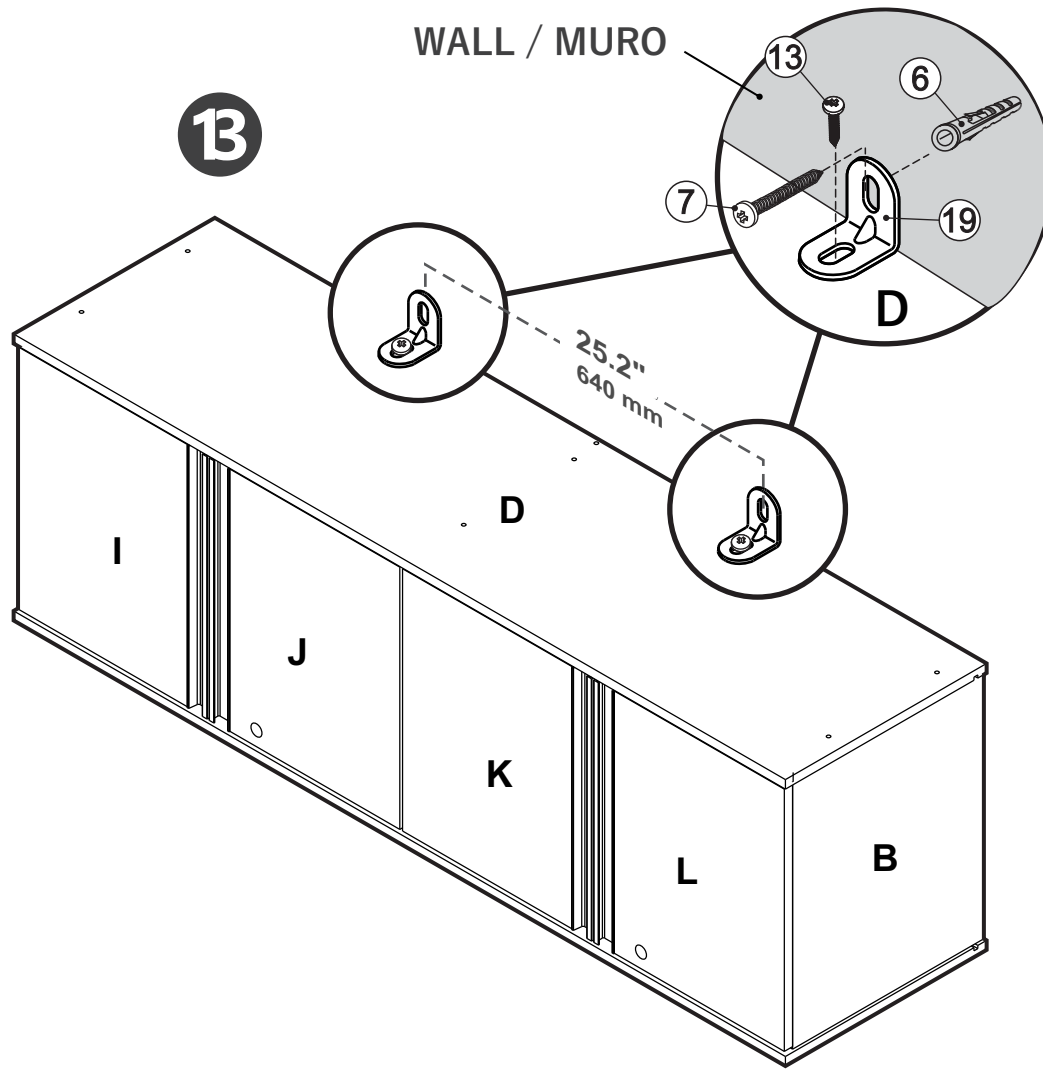

For the cabinet installation, please read the instructions sheet carefully/
 Para la instalación del gabinete, por favor leer la hoja de instrucciones detalladamente.

PRECAUCIÓN

CAUTION 

WALL / MURO

To fix the furniture, drill the wall using a (tungsten) 5/16" drill, then insert the plastic anchor. Secure the furniture using the anchor screws.

Para fijar el mueble, perfore la pared con ayuda de una broca para pared (tungsteno) 5/16", después introduzca el chazo plástico (# 10) asegure el Mueble con tornillos chazo (#9).

CONGRATULATIONS!, this way you finished assembling your furniture.

¡FELICITACIONES!, de esta manera usted termina de armar su mueble.

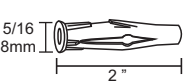
	X 2
6 WALL ANCHOR CHAZO ANCLA	

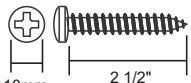
	X 2
7 WALL SCREW TORNILLO A PARED	

	X 2
13 HINGES-SCREWS TORNILLO-BISAGRAS	

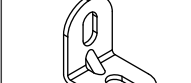
	X 2
17 ANGLE BRACKET ÁNGULO METALICO	