

ASSEMBLY INSTRUCTIONS

Customer Service : cs@nbrehome.com

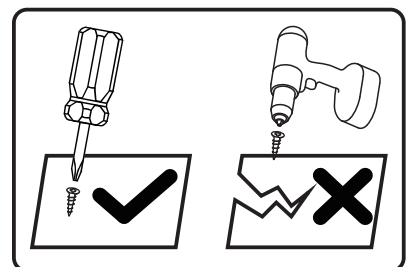
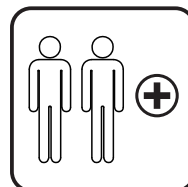
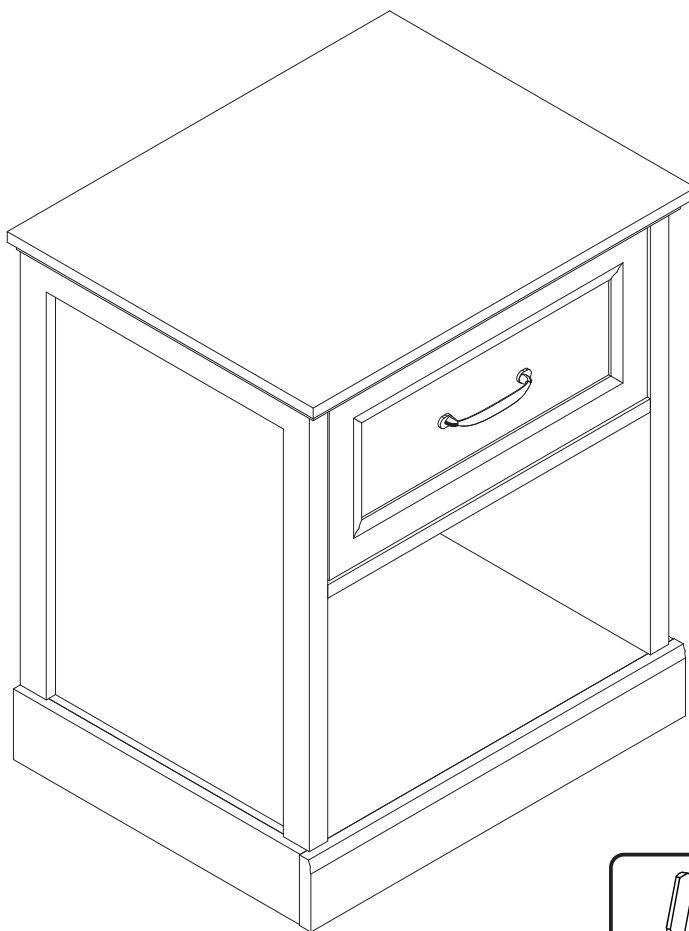

Tools Recommended

THIS INSTRUCTIONS CONTAINS IMPORTANT SAFETY INFORMATION.
PLEASE READ BEFORE ASSEMBLY AND KEEP FOR FUTURE REFERENCE.

Need Parts or Assistance? Email us : cs@nbrehome.com

IMPORTANT NOTICE

-This product contains small components, please ensure that they are kept away from small children.

-THIS INSTRUCTIONS CONTAINS IMPORTANT SAFETY INFORMATION.
PLEASE READ BEFORE ASSEMBLY AND KEEP FOR FUTURE REFERENCE.

-Read each step carefully. It is very important that each step of instruction is performed in the correct order. If these steps are not followed in sequence, assembly difficulties will occur.

-Make sure all parts are included. Most parts are labelled or stamped on the raw edge.

-Work in spacious area, preferably on a carpet, near the place the unit will be used.

-Do not use power tools to assemble your furniture. Power tools may strip or damage the parts.

-Move your new furniture carefully, with two people lift and carry the unit to it's new location.

-Never push, drag or pull your furniture (especially on carpet)



PLEASE DO NOT RETURN PRODUCT TO US IMMEDIATELY

If a part is missing or damaged, email our customer service.
We will gladly ship your replacement parts FREE of charge.

Need Parts or Assistance? Email us : cs@nbrehome.com

For Prompt, reliable service, please have your assemble instruction ready

 WARNING	
	Children have died from furniture tipover. To reduce the risk of furniture tipover: <ul style="list-style-type: none">• ALWAYS install anti-tip device provided.• NEVER put a TV on this product.• NEVER allow children to stand, climb or hang on any drawers, doors, or shelves.• NEVER open more than one drawer at a time.• Place heaviest items in the lowest drawers.
	<p>This is a permanent label. Do not remove!</p>

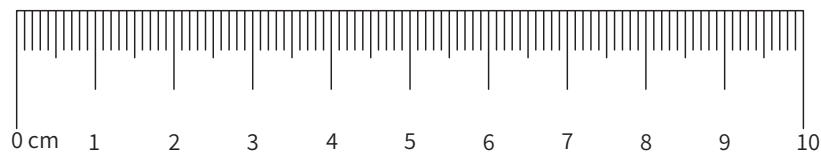
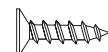
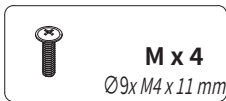
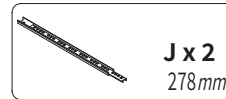
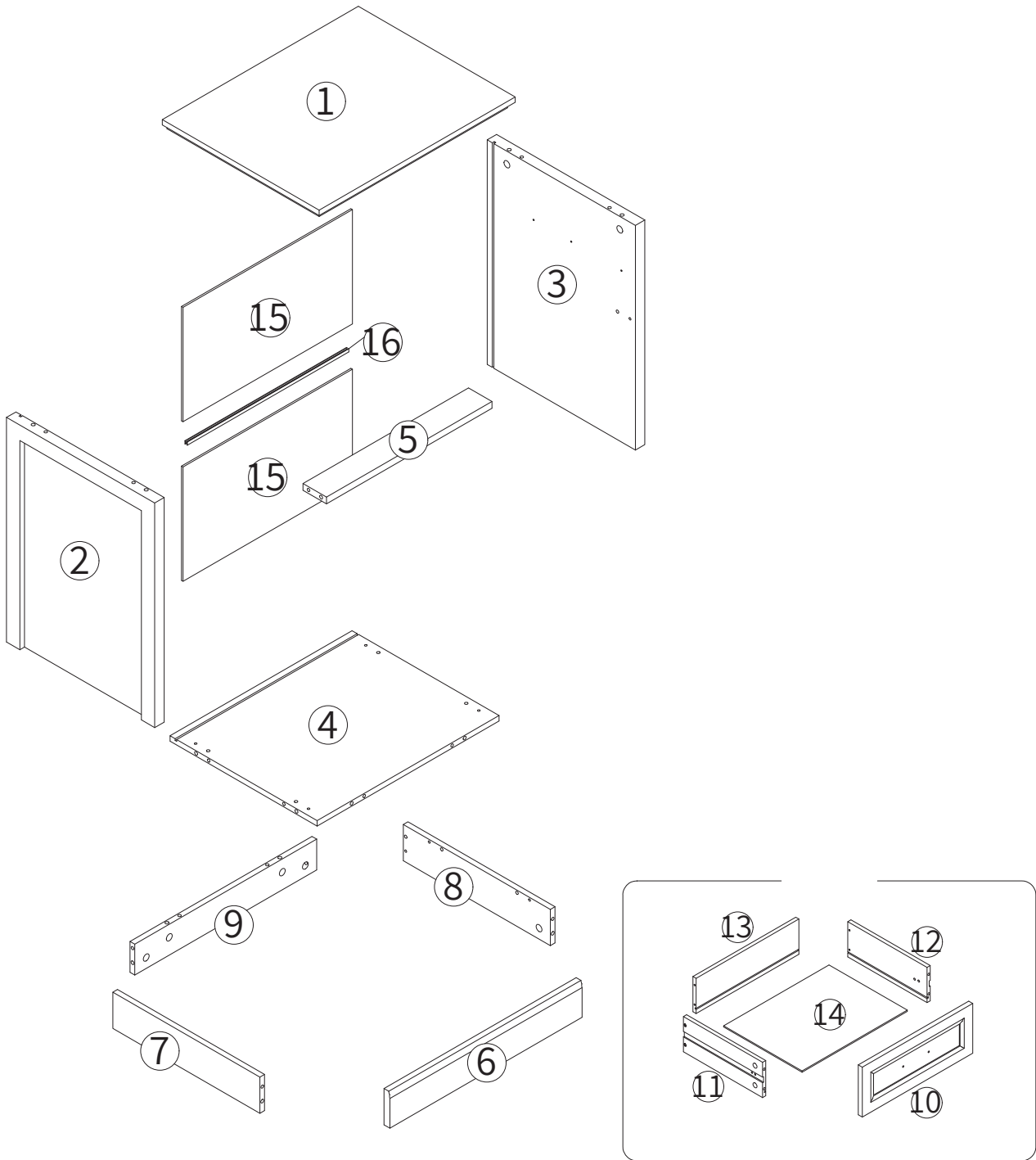

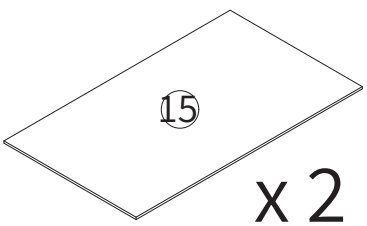
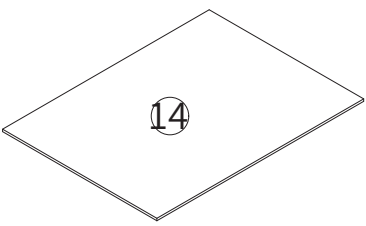
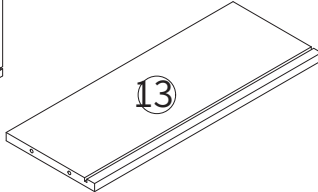
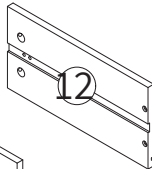
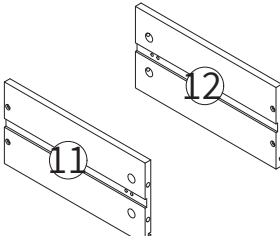
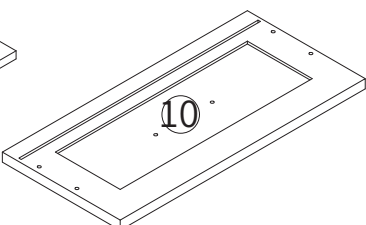
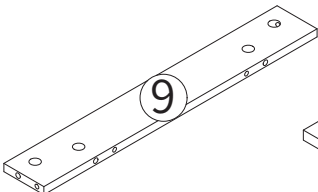
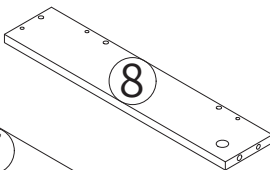
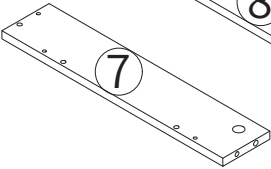
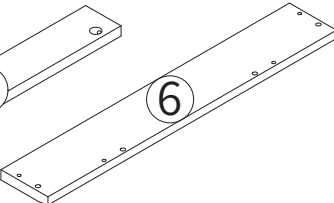
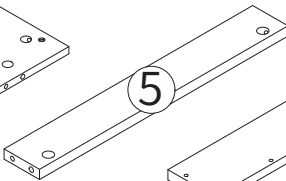
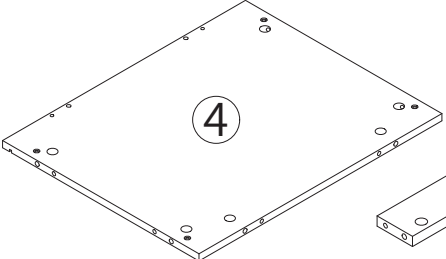
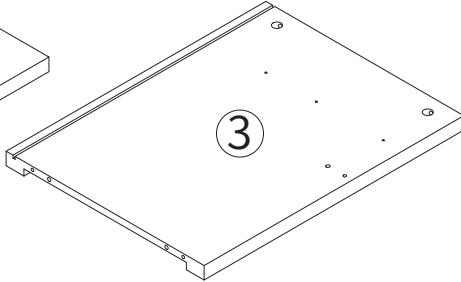
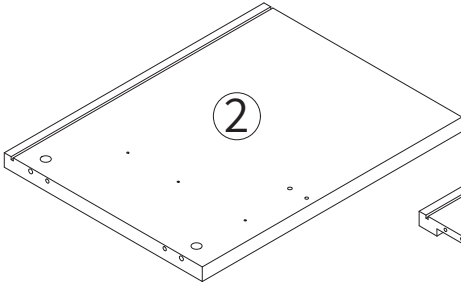
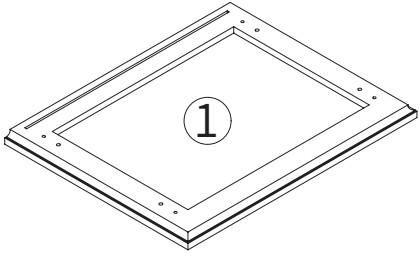

x 2

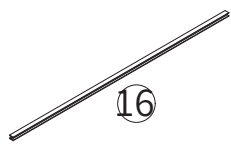

Step 1

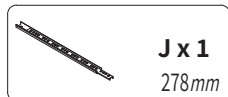
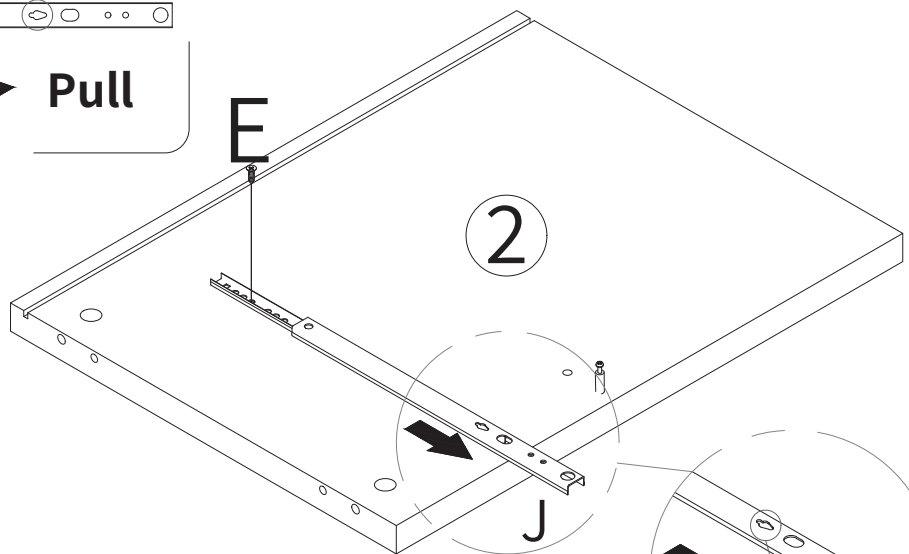
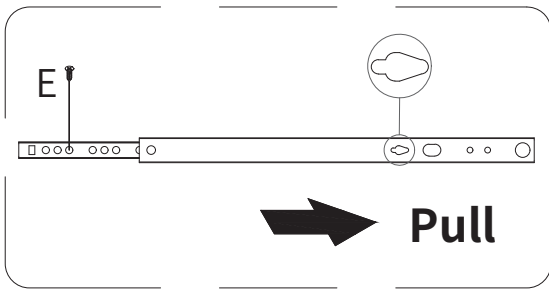
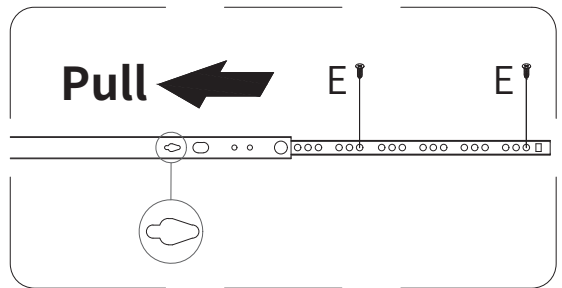
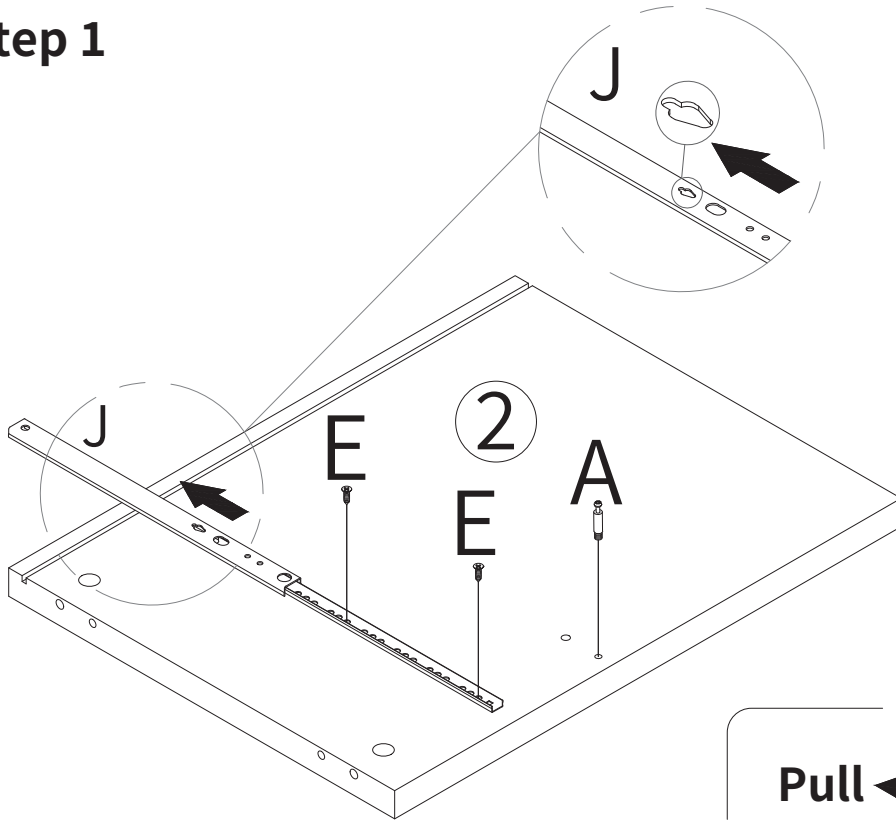

Step 2

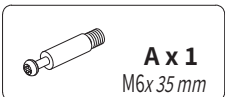
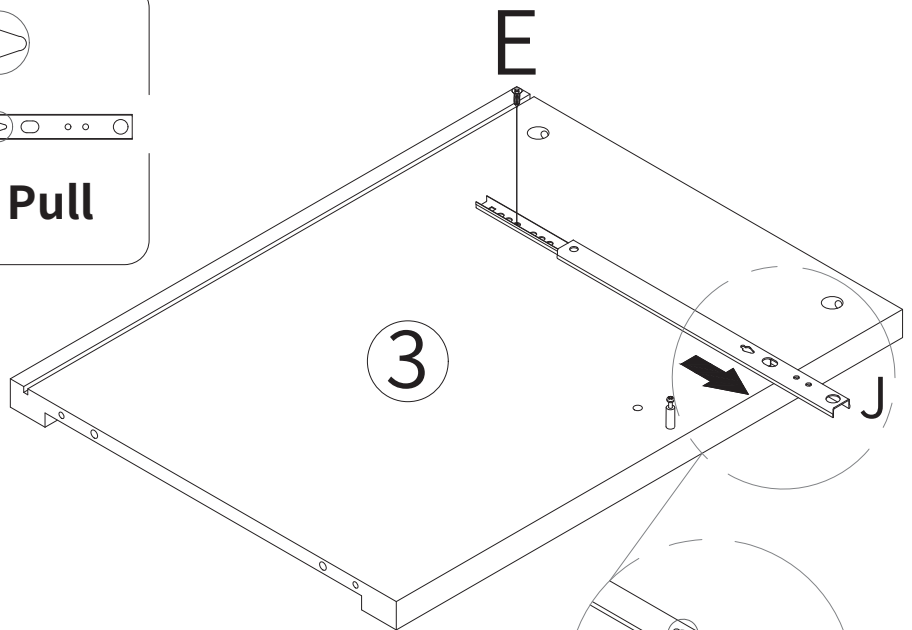
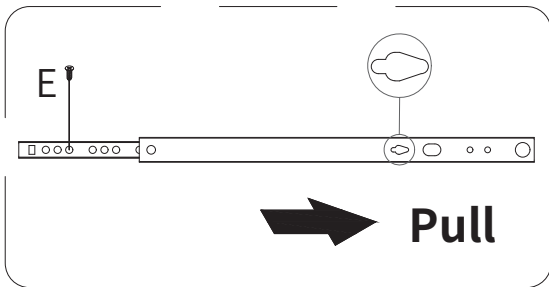
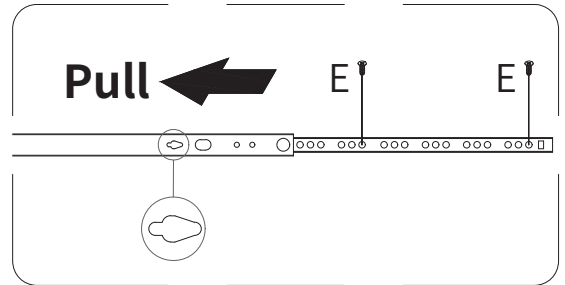
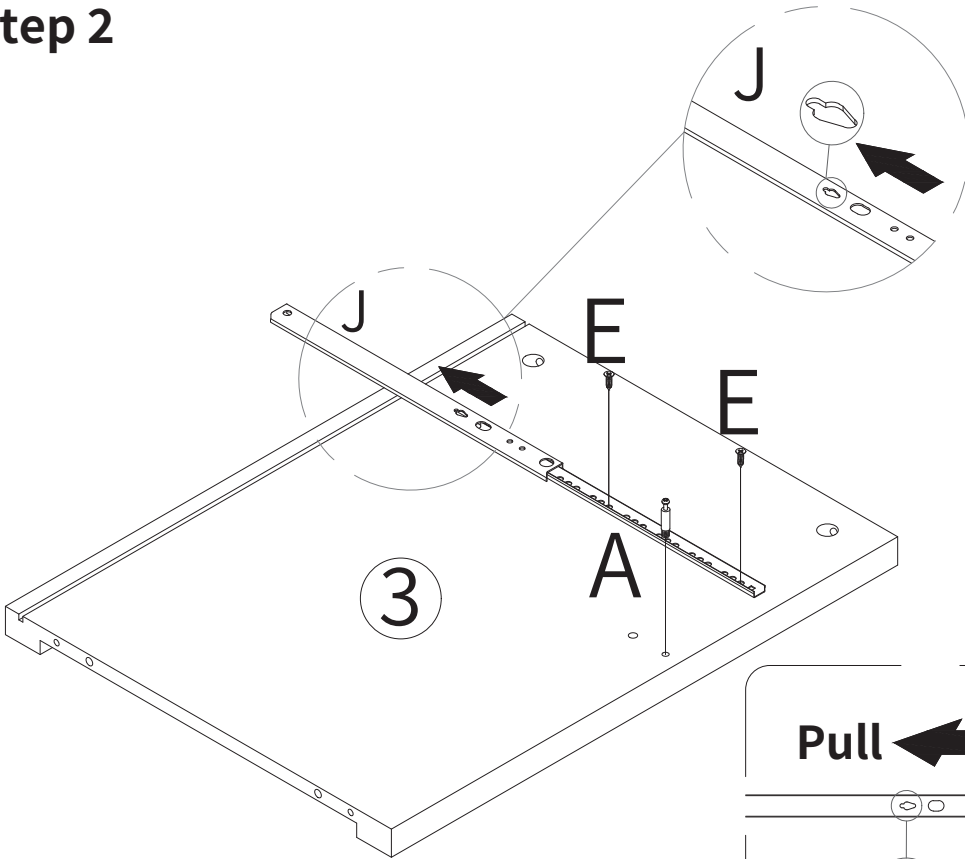

Step 3

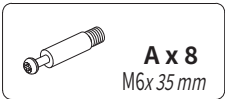
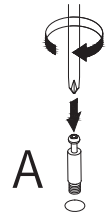
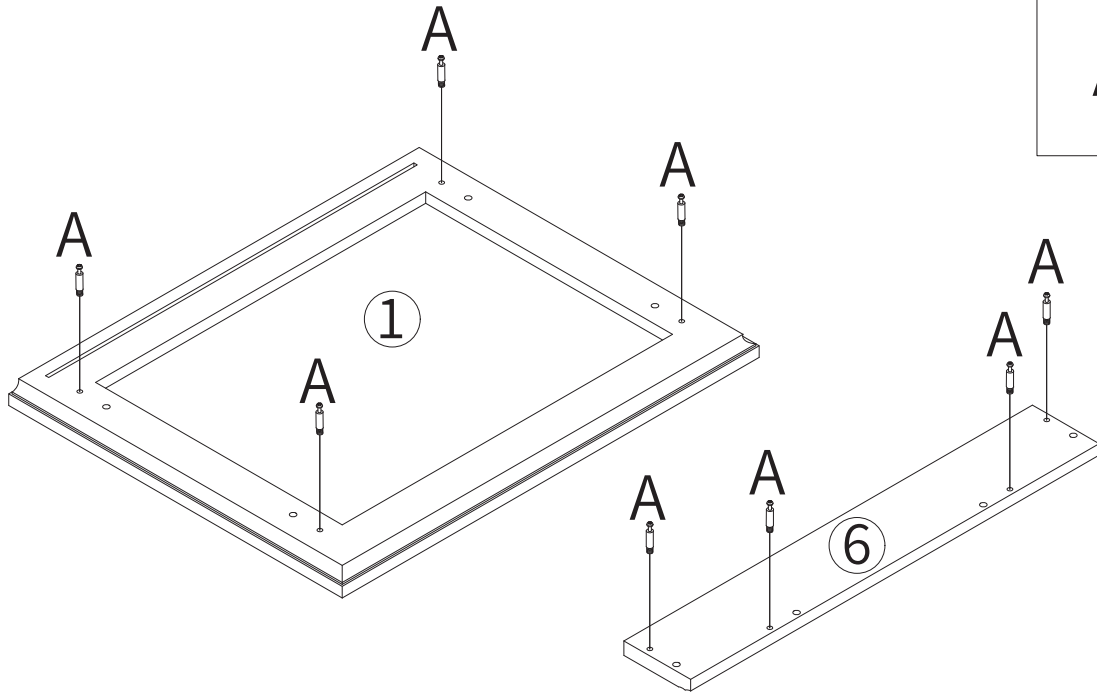

Step 4

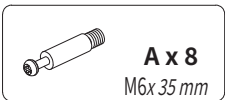
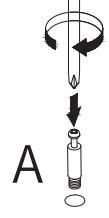
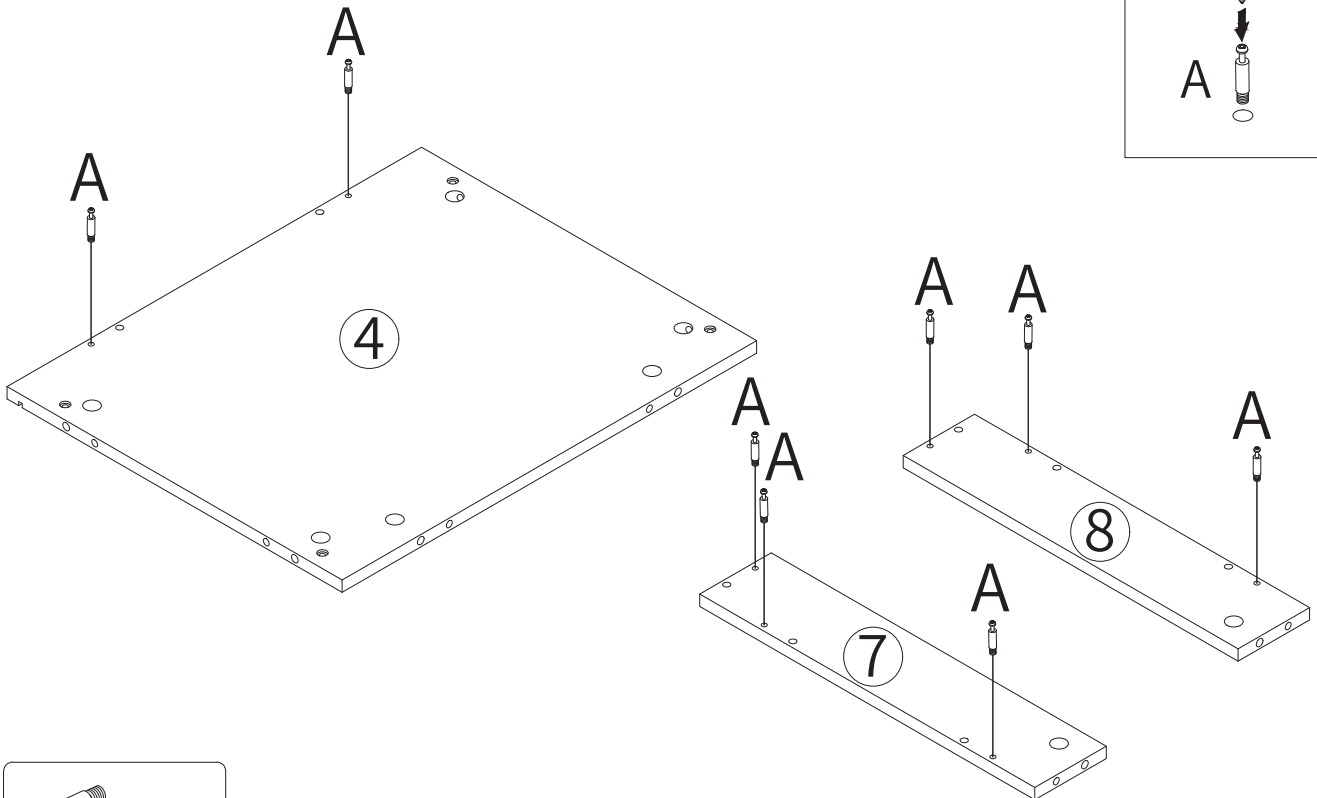

Step 5

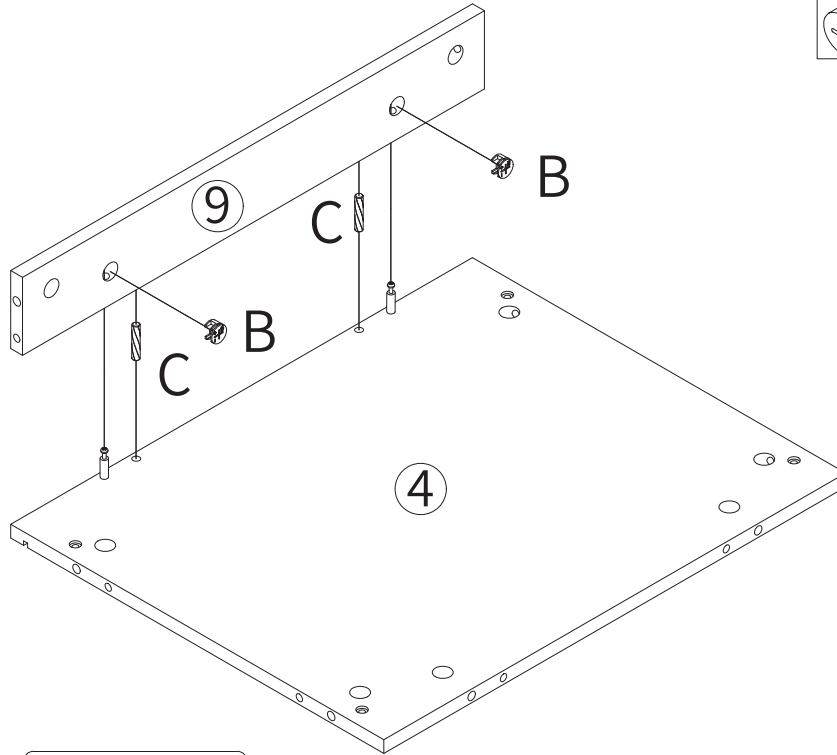

Step 6

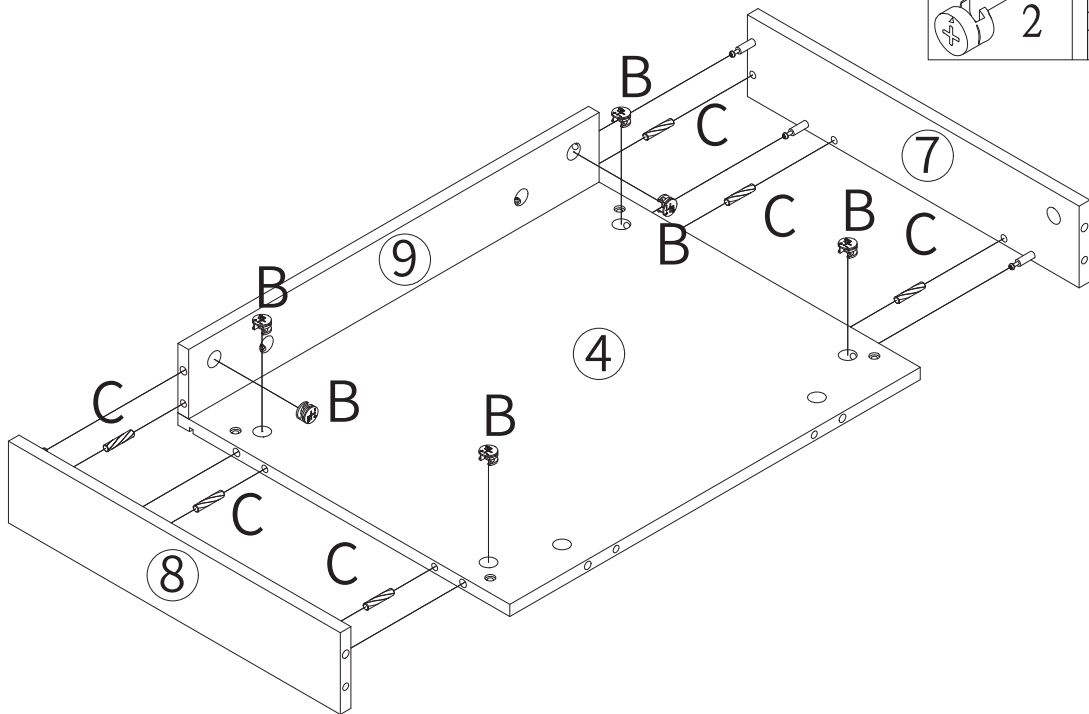

Step 7

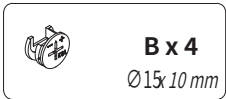
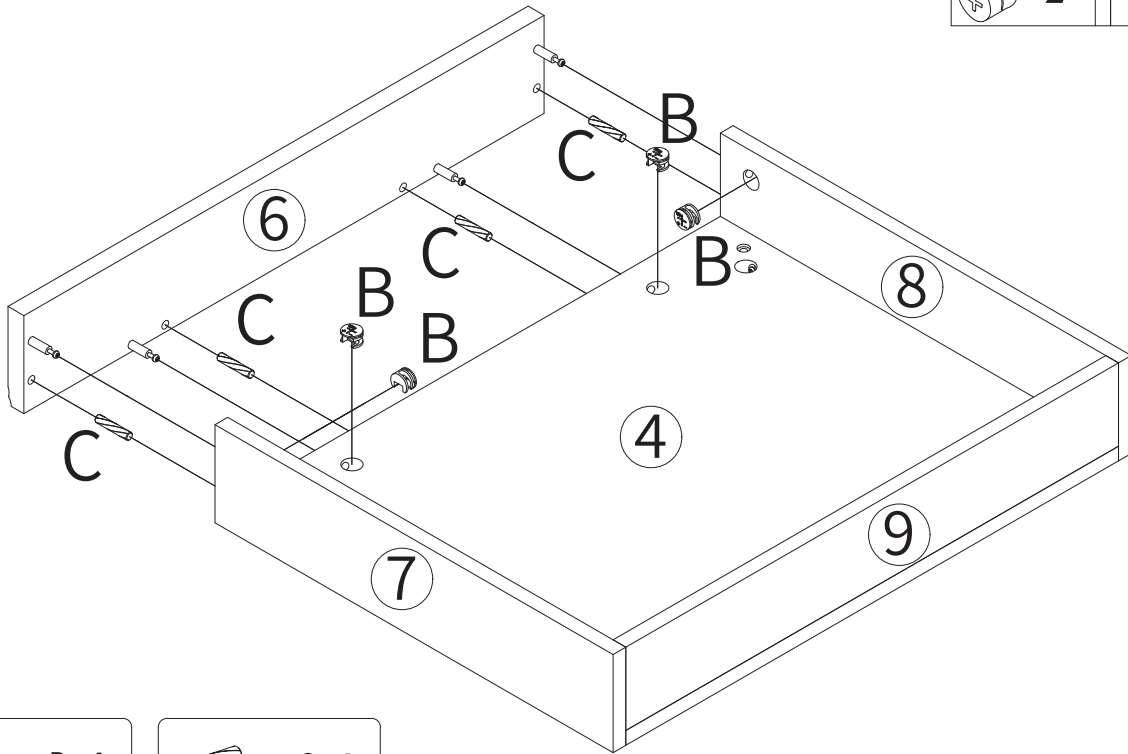

Step 8

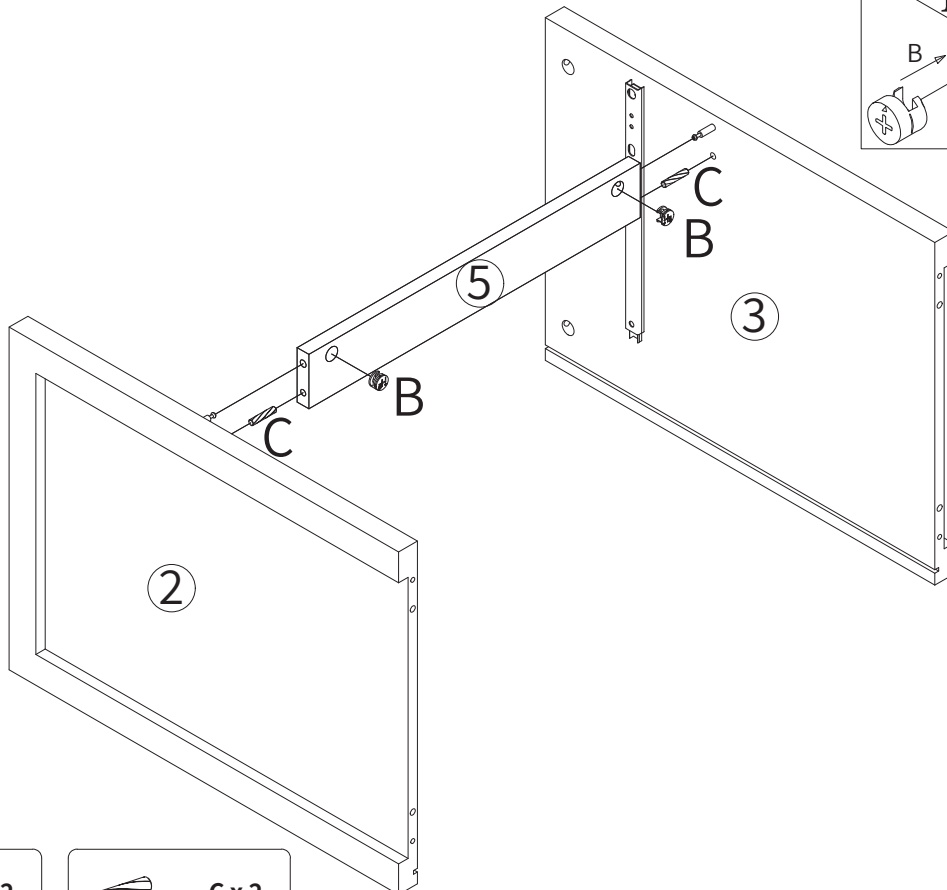

Step 9

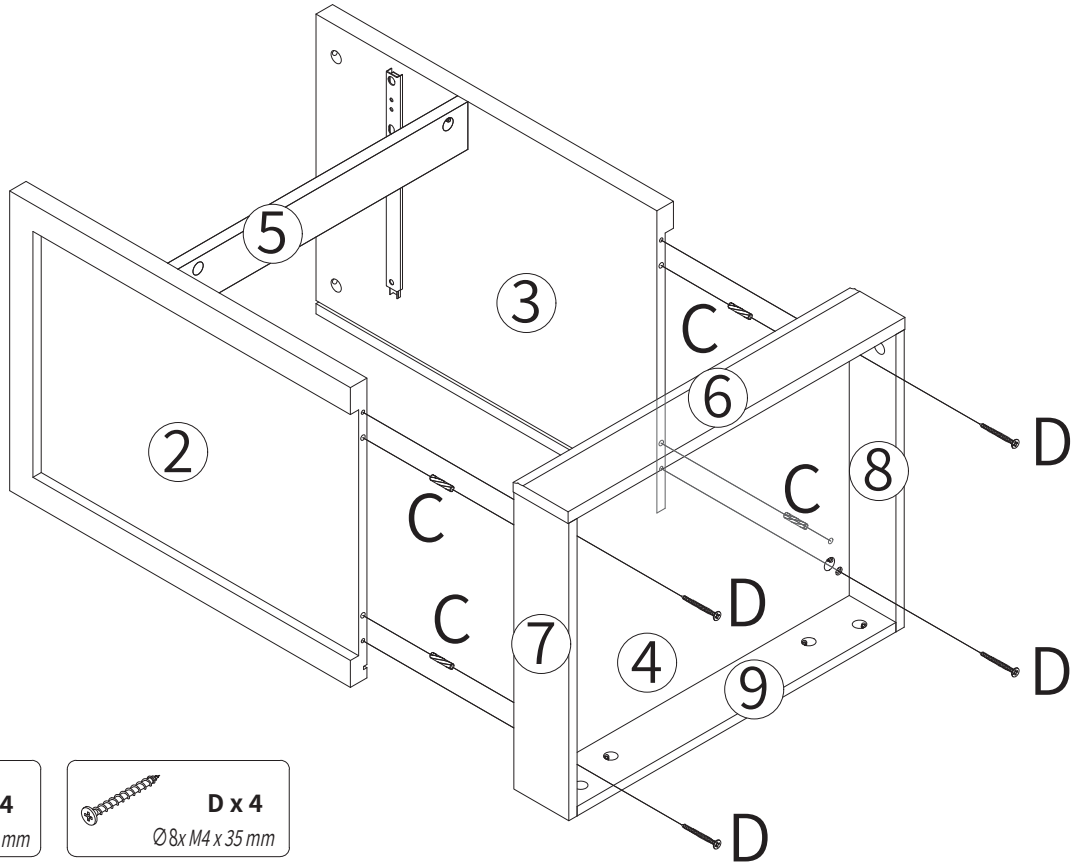

Step 10

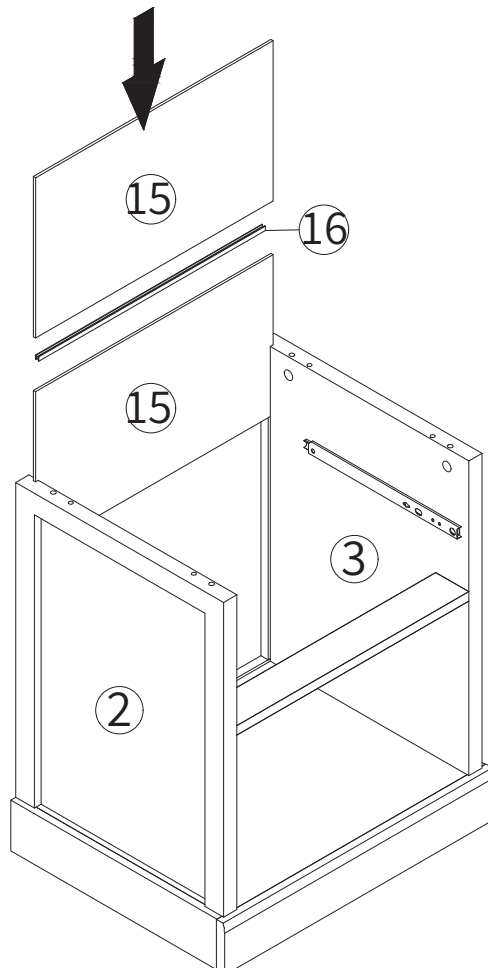

Step 11

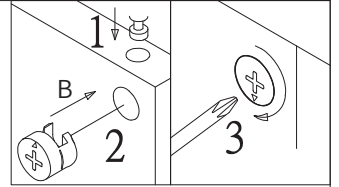
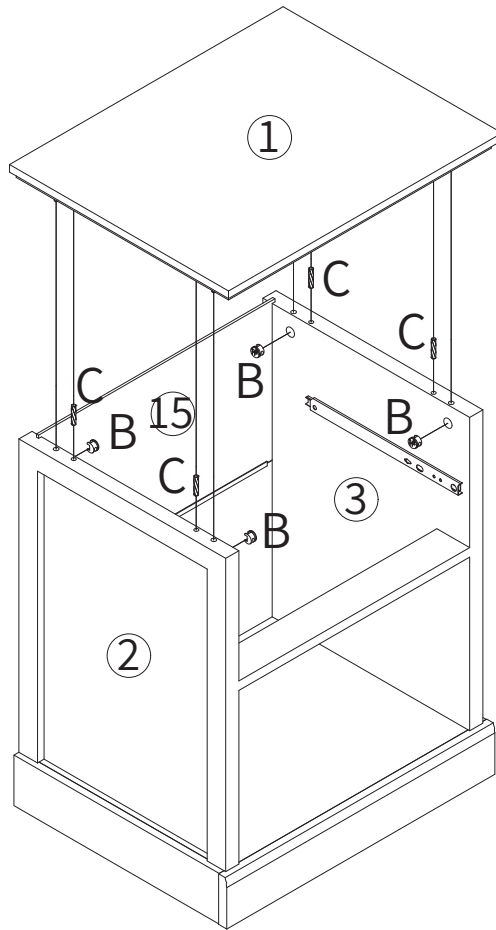

Step 12

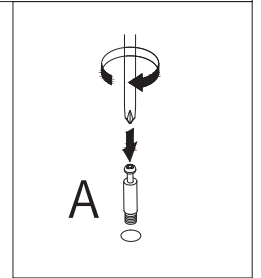
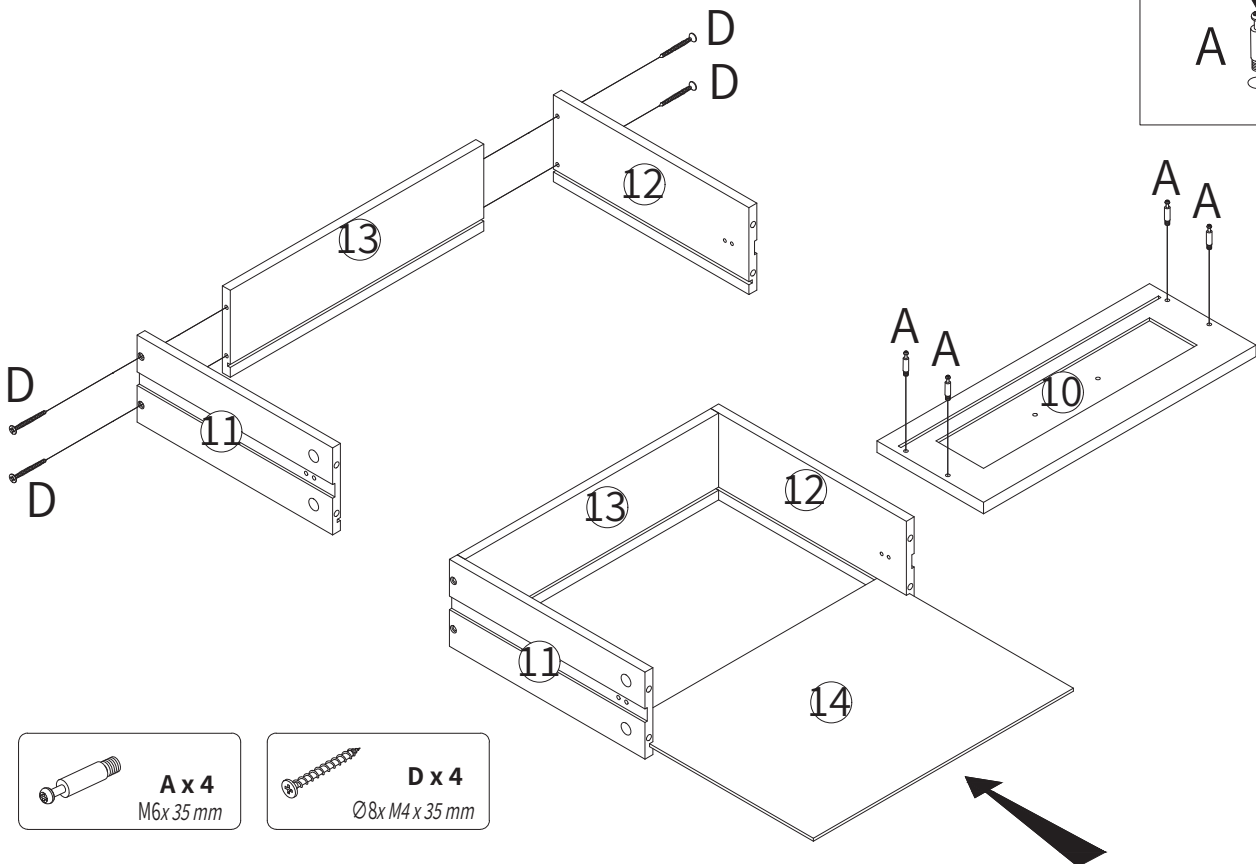

Step 13

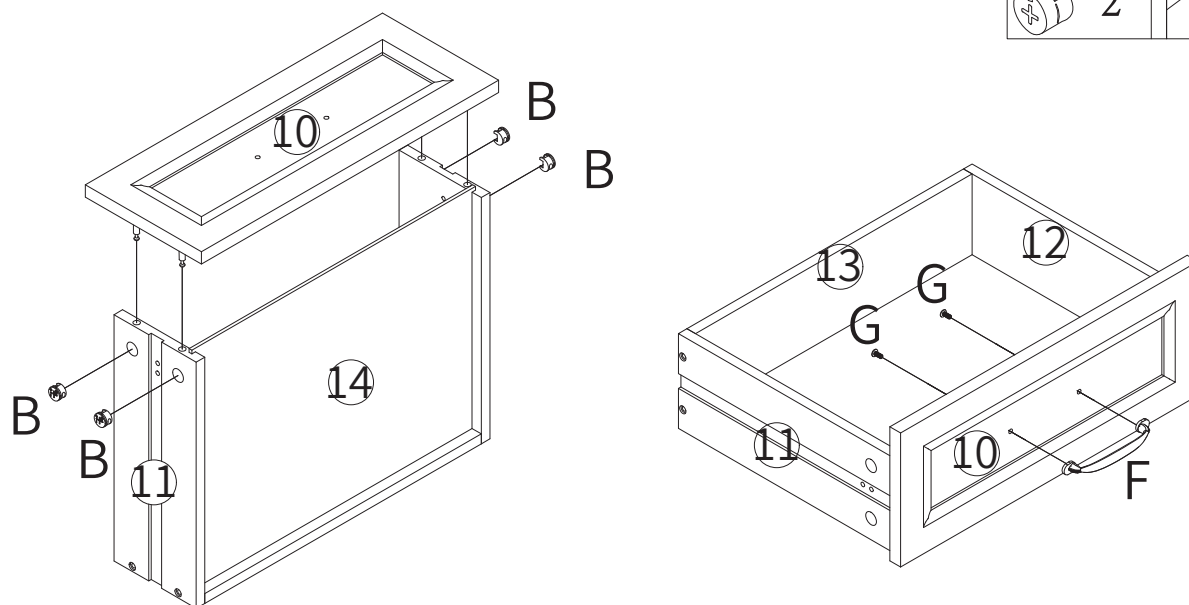
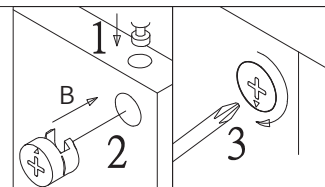

Step 14

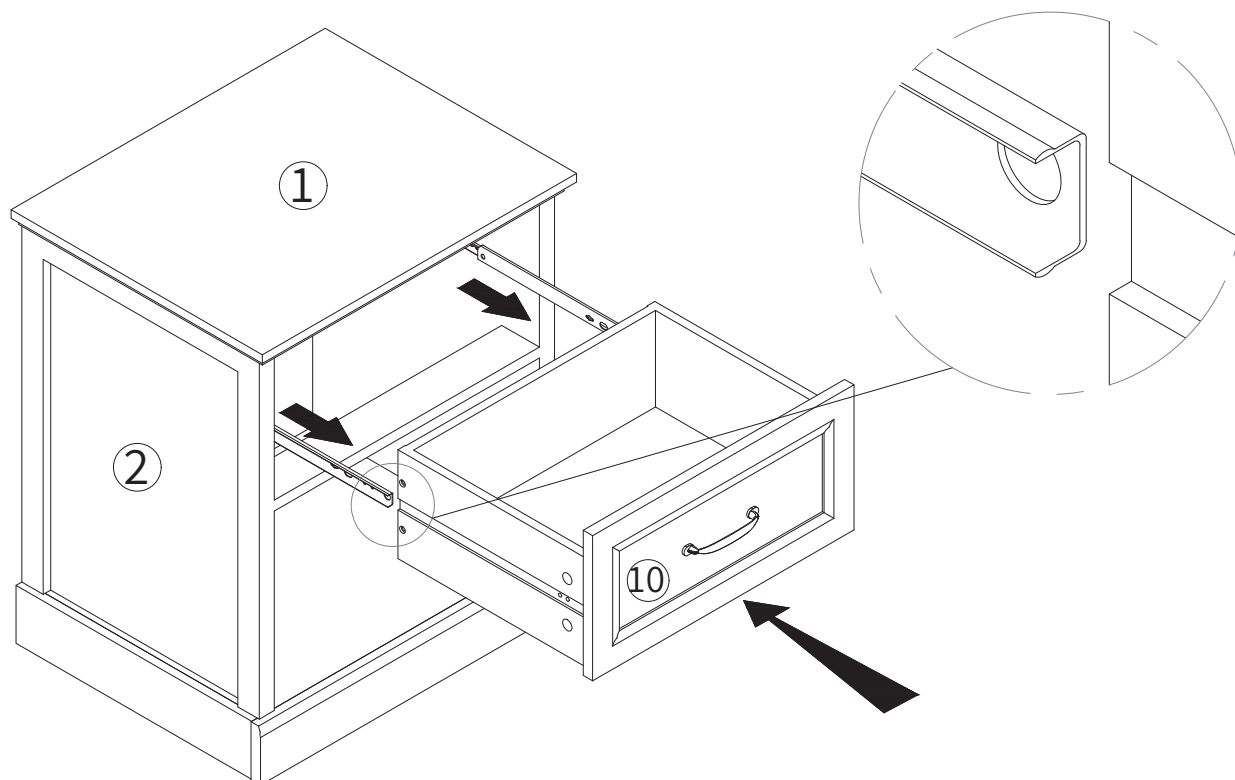

Step 15

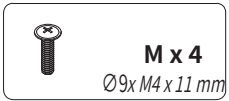
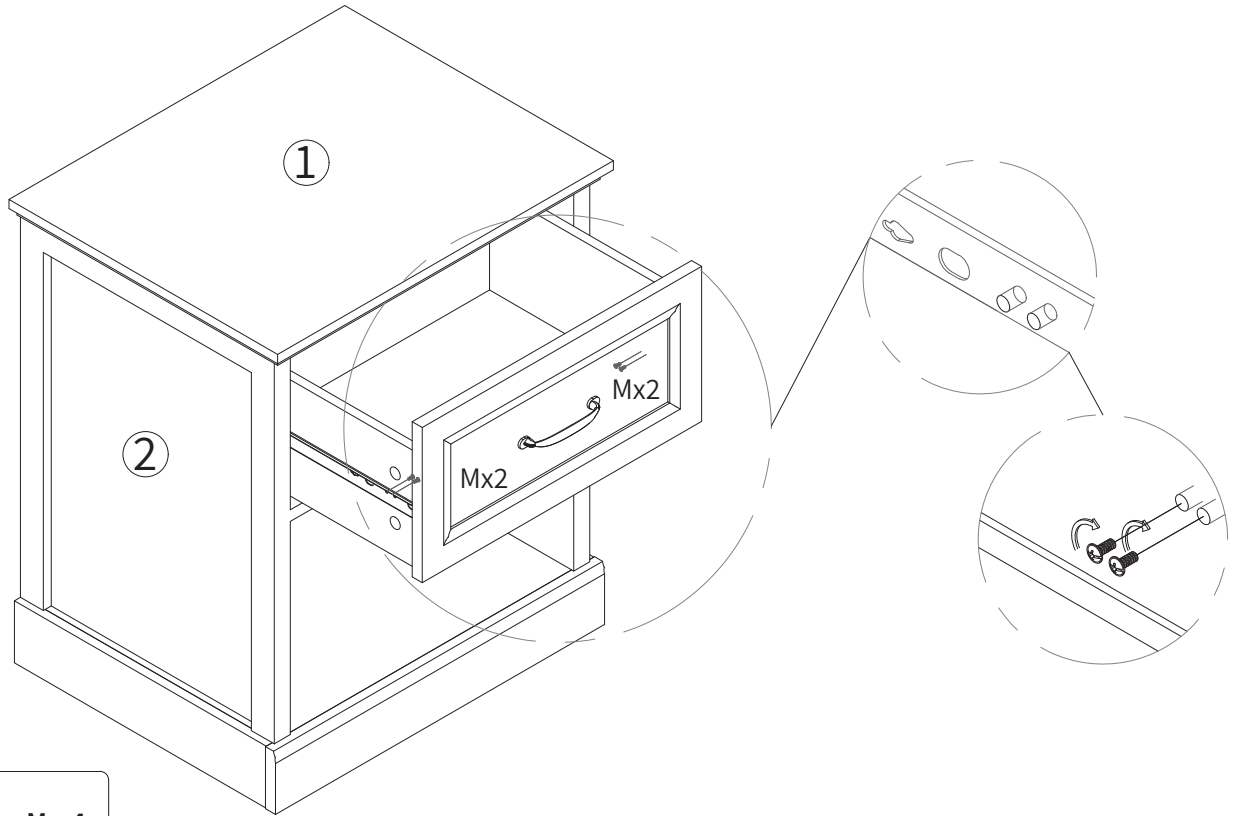

Step 16

