

THANK YOU SO MUCH FOR PURCHASING OUR PRODUCT. IF YOU HAVE ANY TROUBLE PUTTING YOUR KIT TOGETHER OR MISSING PIECES PLEASE CONTACT US.

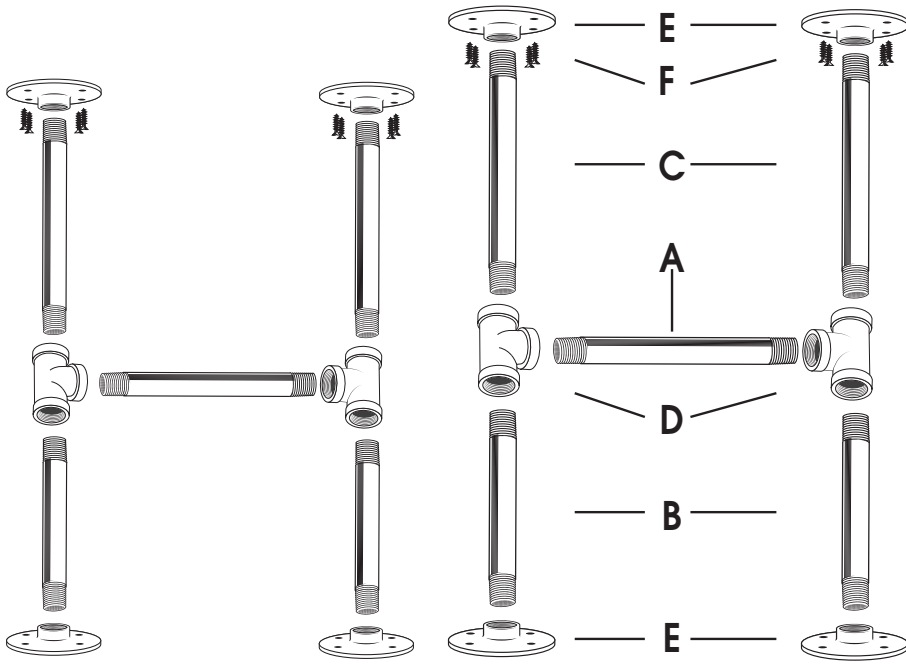

Parts List:

- A - 1/2" X 12" PIPE (2 PCS)
- B - 1/2" X 8" PIPE (4 PCS)
- C - 1/2" X 10" PIPE (4 PCS)
- D - 1/2" TEES (4 PCS)
- E - 1/2" FLANGES (3" OD)(8 PCS)
- F - Screws (16 PCS)

This is industrial grade authentic pipe. It comes covered in anti-rust oil. They are dirty to the touch but can be cleaned and sealed to prevent rust and be clean to the touch. See Clean and Seal sheet for ways to clean and seal the pipe.

1. Connect 8" Pipe (B) and 10" Pipe (C) to Tees (D)
2. Connect both sides with 12" Pipe(A) to Tees (D)
3. Connect Flanges (E) to the ends of Pipe (B&C).
4. Repeat steps 1-3 for other side.
5. Tighten each leg by hand.
6. Screw Legs into table top with Screws (F)

Flanges may scratch floor and pads are recommended.

RECOMMENDED TOOLS

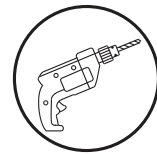

RECOMMENDED
DRILL WITH 1/4" BIT
FOR WALL ANCHOR

PREPPING THE PIPE

VERY IMPORTANT: These are all authentic malleable iron and require necessary cleaning and prepping; do not skip this step.

1. Clean and dry all the parts with gentle soap.
2. Use a lint-free rag to apply metal polish to the parts.
3. Use metal polish or clear coat paint to seal the dry pipe.