

# **Commercial Cash Register**

(V5.0 version)

## **User Manual**

# Table of Contents

<b><u>Chapter 1 Brief Introduction of Cash Register</u></b> .....	5
1. Safety instructions .....	5
2. Overview .....	6
3. Parts list.....	6
4. Introduction of the cash register.....	7
5. Keyboard distribution diagram .....	7
6. Description of keyboard function .....	8
<b><u>Chapter 2 Initial installation of cash register</u></b> .....	9
1. Time setting.....	9
2. Initialize the machine.....	9
3. Setting of the title and ending.....	9
4. Setting of barcode scanner (set without modification).....	11
<b><u>Chapter 3 Various Programming and Sales</u></b> .....	12
1. Commodity (PLU).....	12
2. Category (DEPT).....	14
3. Direct commodity (DPLU).....	15
4. Package.....	16
5. Checkout Counter.....	17
6. Keyboard custom programming.....	19
<b><u>Chapter 4. Member function</u></b> .....	20
1. Member programming.....	20
2. Rules of member point growth.....	20
3. Member function commodity (PLU).....	21
4. Member function category (DEPT).....	22
5. Member function direct commodity (DPLU).....	23
6. Member function package.....	24
7. Operation of member point exchange.....	26
<b><u>Chapter 5 Multiple sales methods and settlement methods</u></b> .....	27
1. Return.....	27
2. Multiple pieces sales.....	28

3. Sales at variable price.....	28
4. A ban on sales at variable prices.....	29
5. Electronic barcode scale sales.....	30
6. Settlement at a discount.....	31
7. Settlement of added service charge.....	31
8. Preferential settlement.....	32
9. Remove mantissa for settlement.....	33
10. Cash settlement and change.....	33
11. Credit card settlement.....	34
12. Foreign exchange.....	34
13. Signing.....	35
14. Unified adding-taxes.....	36
15. Member setting.....	37
<b>Chapter 6. Personnel management and password setting.....</b>	<b>38</b>
1. Cashier.....	38
2. Shop assistant.....	39
3. Lock and unlock.....	39
<b>Chapter 7. Manager management.....</b>	<b>41</b>
1. Delete single programming.....	41
2. Delete all programming.....	41
3. Recovery of factory settings.....	41
4. Manager password control.....	42
5. Change manager password.....	42
6. Cancel the use of manager password.....	43
<b>Chapter 8. Self-testing of cash registers.....</b>	<b>44</b>
1. Full test.....	44
2. Main display screen test.....	44
3. Second display screen test.....	44
4. Keyboard test.....	44
5. Print test.....	45
6. COM1 test.....	45
7. COM2 test.....	46
8. USB flash disk test.....	46

9. Cashbox test.....	46
<b>Chapter 9. Various interfaces.....</b>	<b>47</b>
1. USB flash disk use.....	47
2. Connect USB to PC.....	48
3. Connect communication port to PC.....	48
4. Communication port is connected with POS.....	48
5. Communication port is connected with price computing scales.....	49
6. Barcode port is connected with POS.....	50
7. Connect barcode port to barcode gun.....	50
<b>Chapter 10. Sales pretreatment.....</b>	<b>51</b>
1. Sales of commodity font size in the receipt.....	51
2. Settlement font size in the receipt.....	51
3. Repeat print bill.....	51
4. Open the cashbox.....	52
5. Cash withdrawal and deposit due to abnormal sales.....	52
6. Ban/allow built-in printing.....	53
7. Bill printing speed.....	54
8. Error correction.....	54
9. Cancel.....	55
10. System information.....	55
<b>Chapter 11. Various statements.....</b>	<b>56</b>
1. Financial statement.....	56
2. Hourly report.....	56
3. Daily detail report.....	56
4. Monthly detail report.....	57
5. Receipt report.....	57
6. Operating statement.....	58
7. Signing report.....	58
8. Sales return report.....	58
9. Commodity (PLU) report.....	59
10. Category (DEPT) report.....	59
11. Direct commodity (DPLU) report.....	60
12. Checkout counter report.....	60

13. Checkout counter list.....	60
14. Package report.....	61
15. Report summary.....	61
16. Report empty.....	62
17. Inventory alarm.....	62
18. PLU daily detail report.....	62
19. Member points.....	63
20. Clear away serial number.....	63
<b><u>Appendix A: System Function Parameter Definition List.....</u></b>	<b>64</b>
<b><u>Appendix B: Keyboard custom key value comparison table.....</u></b>	<b>68</b>
<b><u>Appendix C: Common problem-solving methods of cash register.....</u></b>	<b>69</b>
<b><u>Appendix D: Receipt sample.....</u></b>	<b>72</b>

# Chapter 1 Brief Introduction of Cash Register

## 1. Safety instructions

- 1) Please read the safety instructions carefully.
- 2) Please keep the use manual properly for future reference.
- 3) Please keep the equipment dry and keep it away from humid environment.
- 4) Place the equipment on the stable plane before the assembly and use.
- 5) Before connecting the equipment with the power supply, please confirm that the power supply is 100V-240V, 50Hz, 0.4A-0.2A.
- 6) The equipment shall be connected with the power line correctly.
- 7) Please pay attention to all the notes and warnings indicated on the equipment and in the manual.
- 8) Don't inject any liquid from the opening, otherwise it will have serious damage and even lead to electric shock.
- 9) When inserting the external disk and U-disk, please make virus killing processing in order to prevent virus infection.
- 10) In case of the following situations, please find technical service personnel for handling:
  - Power line or plug damaged
  - Liquid infiltrates into equipment
  - Equipment falls or is hit
  - The equipment has the obvious damage sign
  - Equipment can't work normally or user fails to avoid the virus infection according to the guidance in the user manual for making it work normally.

**Statement:** It is Grade-A product. Such product may receive the radio jamming under the life environment. On this occasion, the user shall take the practical and feasible measures. Cash box mouth is not applicable to the telecommunication network but to RJ11 cash box interface.



**Warning:** Please don't place or store the equipment under the environment with a temperature of more than 45°C (113°F), otherwise it will damage the equipment.

**Note:** Page Up and Page Down key on the machine respectively are: Page Up key [X/Times] Page Down key [Change Price]

**Operation of restoring unfinished work:** Press Power key directly for turning off, hold on [Cash] for turning on, display [Prompt] on the screen, loose [Cash], and press [Total] for OK.

**Operation of restoring keyboard definition:** Press Power key directly for turning off, hold on [Total] for turning on, display [Prompt] on the screen, loose [Total], and press [Total] for OK.

## 2. Overview

We prepare this manual very rigorous, but we can't guarantee that the contents in this manual are absolutely right, which is because our products have been improved and updated. Therefore, our party reserves the right of conducting the modification at any time without notice.

The manual introduces the related contents about the electronic cash register in details. Pay attention to the following one point when using this manual:

The "warning" information in the manual is used to remind the user of keeping special caution during the operation.

- 1) Cashier screen of cash register adopts LCM128\*64 dot matrix, with word display of 16\*16 dot matrix.
- 2) Customer screen adopts 8-bit bright LED digital tube.
- 3) It adopts 58mm thermal line printer engine FTP-628MCL which can print 32 characters or 16 words each line.
- 4) It can select 58mm printing paper for printing. When selecting 58mm printing paper, the word printed by the cash register is 24\*24 dot matrix.
- 5) It has 40 keys, the keyboard layout is reasonable and generous, and key surface is all Chinese, facilitating user operation.
- 6) Cash register is equipped with 2 serial communication ports and USB interface which can be connected externally with PC; bar code scans gun and double POS. The USB flash disk interfaces are provided according to the different models.

## 3. Parts list

Parts list			
No.	Designation	Quantity	Unit
1	Cash register	1	Piece
2	Instructions	1	Book
3	Power line	1	Piece
4	232 Data line	1	Piece
5	Software CD of cash register	1	Piece
6	Guarantee card	1	Piece
7	Product Qualification Certificate	1	Piece
8	Thermal printing paper	1	Roll

#### 4. Introduction of the cash register

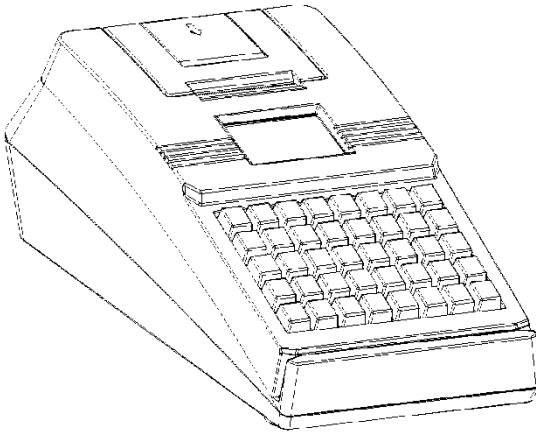

#### 5. Keyboard distribution diagram

Feed	<sup>a</sup> DEPT 10/20	<sup>f</sup> DEPT 5/15	X/Times↑	Change Price ↓	PLU Inway	<sup>s</sup> Error correct Round	<sup>w</sup> Cancel Refund
Shift	<sup>b</sup> DEPT 9/19	<sup>g</sup> DEPT 4/14	<sup>k</sup> 7	<sup>m</sup> 8	<sup>p</sup> 9	<sup>t</sup> DISC P/O	<sup>x</sup> Server R/A
Print	<sup>c</sup> DEPT 8/18	<sup>h</sup> DEPT 3/13	4	<sup>n</sup> 5	<sup>q</sup> 6	<sup>u</sup> Sign Bill	<sup>y</sup> Ex- change
Back- space ←	<sup>d</sup> DEPT 7/17	<sup>i</sup> DEPT 2/12	1	2	3	<sup>v</sup> Clerk	<sup>z</sup> Table
Clear	<sup>e</sup> DEPT 6/16	<sup>j</sup> DEPT 1/11	<sup>l</sup> 0	<sup>o</sup> 00	<sup>r</sup> .	Total (Enter)	Cash (Esc)

## 6. Description of keyboard function

Keyboard name	Key value function
1 [Feed]	Printing paper withdrawing
2 [Shift]	Shift of key function
3 [Print]	Check of commodity programming and duplication of sales list
4 [Backspace]	Clear away a figure when inputting the wrong figure
5 [Clear]	Clear away all figures when inputting the wrong figure
6 [X/Time]	Simultaneous sales of multiple same commodities
7 [Page up]	Make cursor move upwards
8 [Price change]	Change price of PLU commodity sold
9 [Page down]	Make cursor move downwards
10 [PLU]	User keys of commodity PLU
11 [PLU Inway]	Switch of input method during the programming
12 [Error correct]	Cancel one for wrong input of commodity during the selling
13 [Round]	Clear away mantissa during the settlement
14 [Cancel]	Cancel the sales of all commodities during the selling
15 [Refund]	Commodity returned due to quality problem or others
16 [Discount]	Discount
17 [Discount]	Give preferential treatment
18 [P/O]	Cash withdrawal due to abnormal sales
19 [Server]	Amount
20 [R/A]	Cash deposit due to abnormal sales
21 [Sign bill]	Bookkeeping
22 [Exchange]	Use the different currency from the local country
23 [Total]	Confirm the commodity input, determined items and use of price during the settlement
24 [Cash]	Withdrawal of commodity input item and withdrawal and checkout use after the determination
25 [0-9]	Digital selection menu and digital input



(1)  
 (2)  
 \*\*\*\*\* (3)\*\*\*\*\*  
 Store name or company name (4)  
 \*\*\*\*\* (5)\*\*\*\*\*  
 Time: Oct.12, 2015 11: 25 001#0001  
 Cashier: 01 Shop assistant: 01  
 Product name Quantity Unit price Amount

---

Apple	1.00	5.00	5.00
Orange	1.00	3.00	3.00

---

Total number: 2.00  
 Amount in total: 8.00  
 Cash: 8.00

\*\*\*\*\*

Welcome to come again (6)  
 Thank you for shopping with us (7)

Use steps: Press [Cash] and then press [X/Times↑] or [Change Price ↓] for selecting an item, and press [Total]

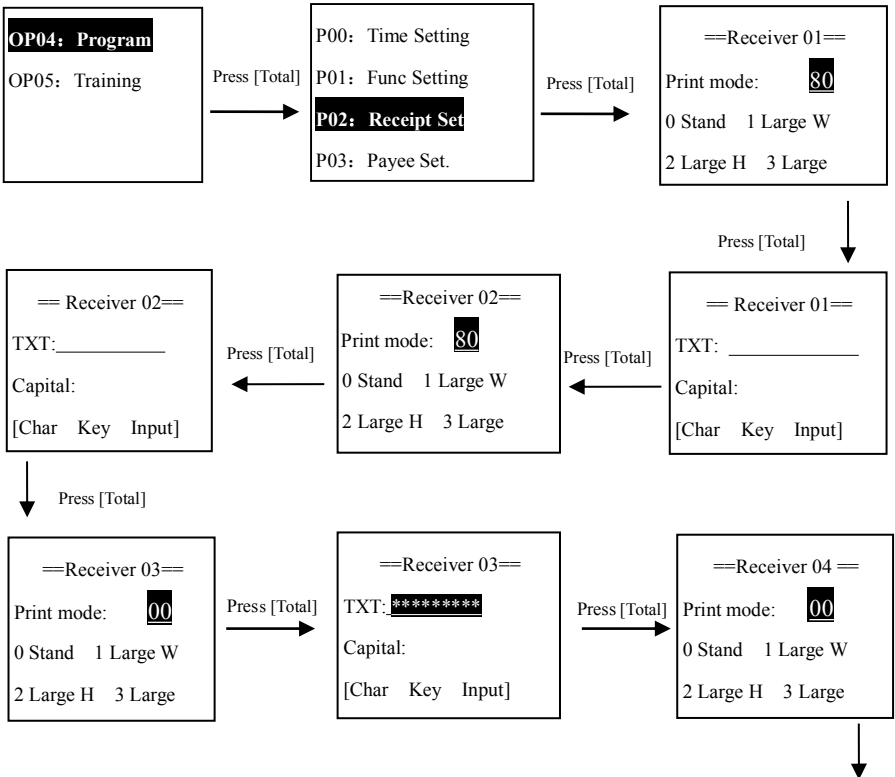

(Continue the unfinished content of last page) ↓

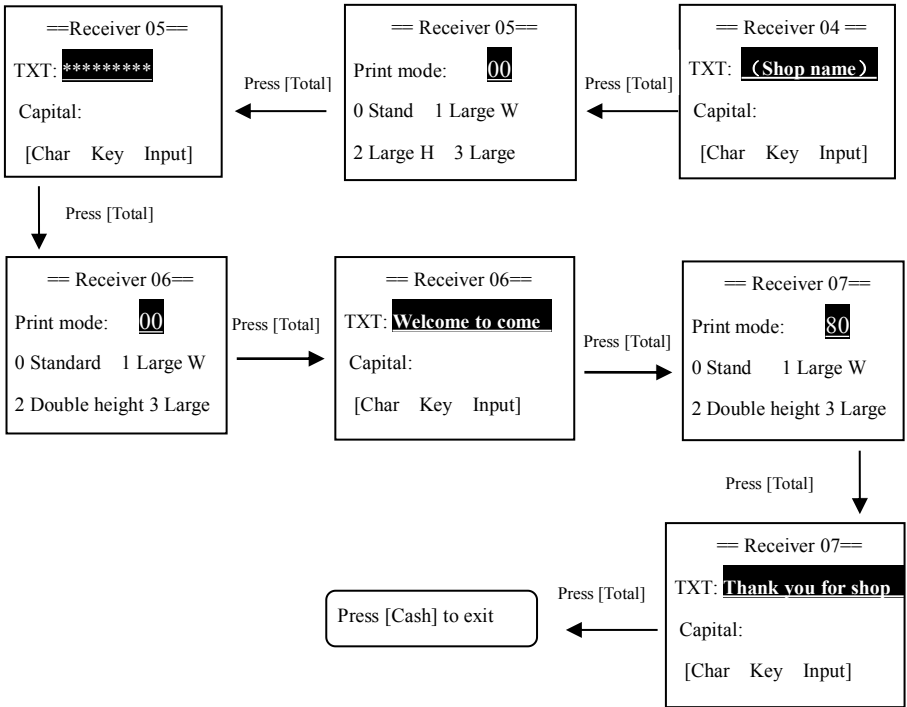

#### 4. Setting of barcode scanner (set without modification)

(Note: cut off the machine power supply when connecting the barcode scanner and setting of barcode scanner shall be conducted according to the manual of barcode scanner).

- 1) Barcode scanner shall be connected to the "barcode interface" of the cash register.
- 2) The communication interface of the barcode scanner shall be RS-232 interface.

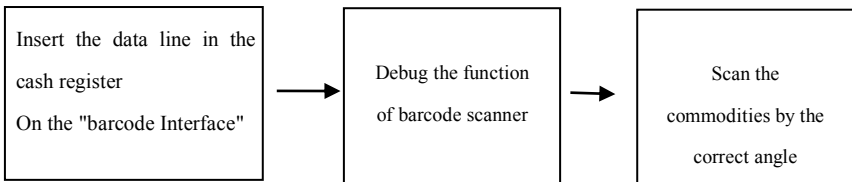

## Chapter 3 Various Programming and Sales

### 1. Commodity (PLU) (Note: The cash register can program 10000 pieces commodities PLU).

PLU sales mean the commodity sales conducted with the commodity code. It can be used together with the multiple pieces sales, temporary price input, discount, service charge and other sales ways, and PLU sales have the function of inventory records and gross margin calculation.

#### (1) PLU programming

Use steps: Press [Cash] and then [X/Times↑] or [Change Price,] for selecting an item, and press [Total]

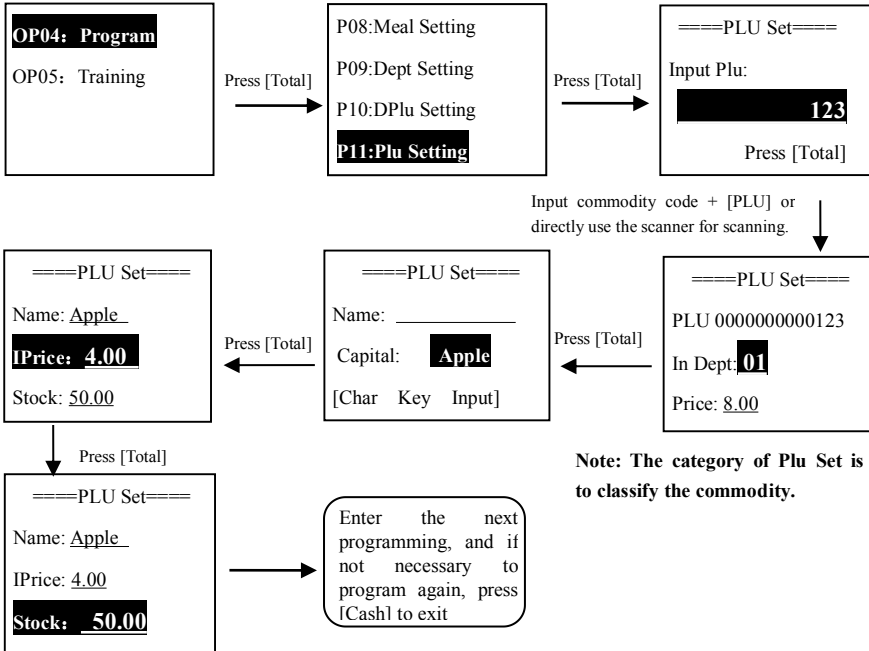

#### (2) PLU deletion

Use steps: Press [Cash] and then press [X/Times↑] or [Change Price,] for selecting an item, and press [Total]

**(During the PLU deletion, first enter the functional programming, press [Total] for selecting programming - "remove mantissa", and set the "remove mantissa" as 1100).**

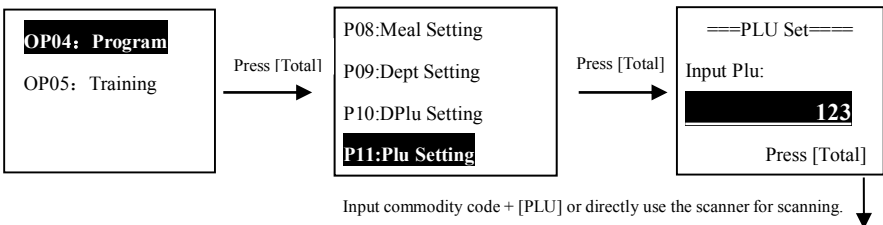

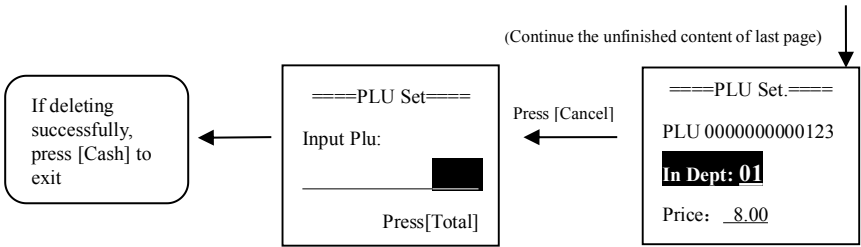

### (3) PLU inventory change

Use steps: Press [Cash] and then press [X/Times↑] or [Change Price↓] for selecting an item, and press [Total] (During PLU inventory change, first enter the functional programming, press [Subtotal] for selecting programming - "remove mantissa", and set the "remove mantissa" as 1100).

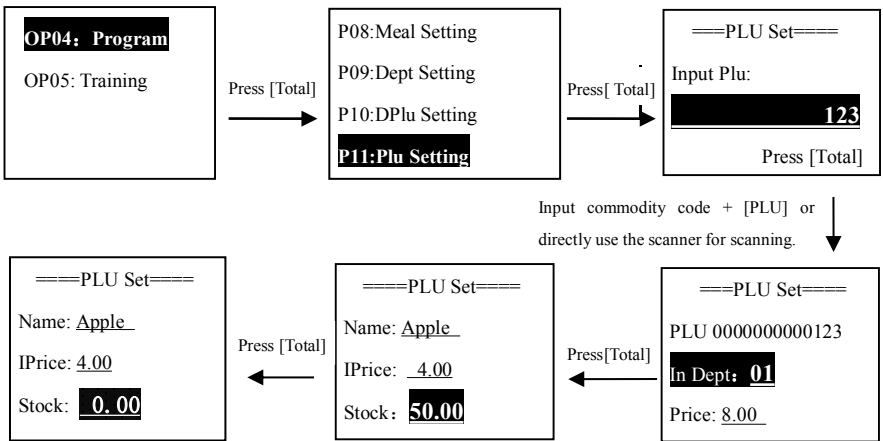

**Input the inventory and press [Total] for completing the correction.**

**Remarks:** During the accumulation of inventory, directly input new inventory quantity, and display the inventory is the accumulated result of current new inventory; when changing the current inventory quantity, press [Cancel] and input the inventory quantity again, and display the current inventory quantity.

### (4) PLU Sales

Use steps: Press [Cash] and then press [X/Times↑] or [Change Price↓] for selecting an item, and press [Total]

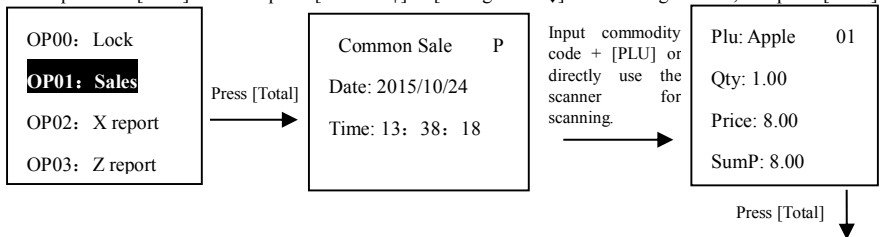

(Continue the unfinished content of last page)

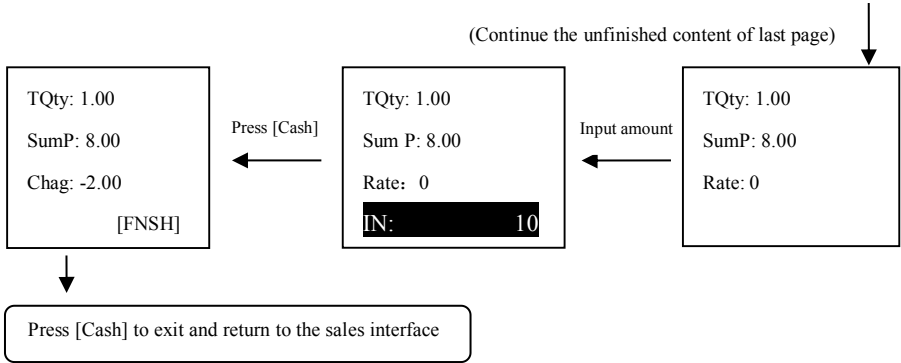

## 2. Category (DEPT) (Note: the cash register can only program 20 categories DEPT)

DEPT sales mean directly using the category key for operation. It can be used together with the multiple pieces sales, temporary price input, discount, service charge and other sales ways, but DEPT sales have no function of inventory records.

### (1) DEPT programming

Use steps: Press [Cash] and then press [X/Times↑] or [Change Price ↓] for selecting an item, and press [Total]

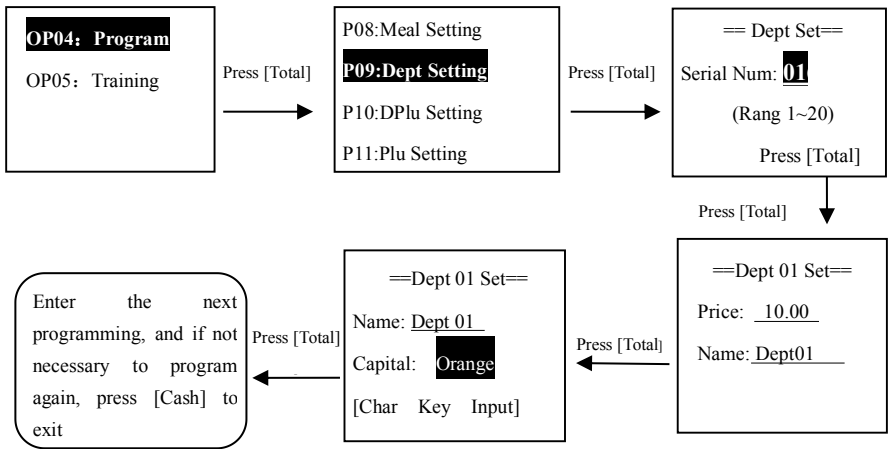

**Notes:** Selection item of the discount is 0-3; such function mainly aims at the operation of overall discount/increase of service charge. In such sales, commodity of different categories can set up the different function value with a factory default value of 0.

Function value 0 means that the commodity allows the operation of discount/increase of service charge;

Function value 1 means that the commodity prohibits the discount, but allows the operation of increase of service charge;

Function value 2 means that the commodity allows the operation of discount, and prohibits the operation of increase of service charge;

Function value 3 means that the commodity doesn't allow the operation of discount/increase of service charge.

**(2) DEPT Sales**

Use steps: Press [Cash] and then press [X/Times↑] or [Change Price↓] for selecting an item, and press [Total]

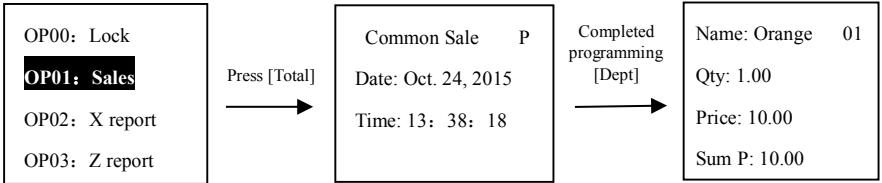

Make a summary calculation after pressing [Total], then input amount + [Cash] settlement or directly press [Cash] for settlement.

**3. Direct commodity (DPLU) (Note: the cash register can only program 6 direct commodities DPLU)**

DPLU sales mean the commodity sales can be conducted directly with no commodity code. It can be used together with the multiple pieces sales, temporary price input, discount, service charge, and direct production (DPLU) sales have the function of inventory records and gross margin calculation.

**(1) DPLU programming**

Use steps: Press [Cash] and then press [X/Times↑] or [Change Price↓] for selecting an item, and press [Total]

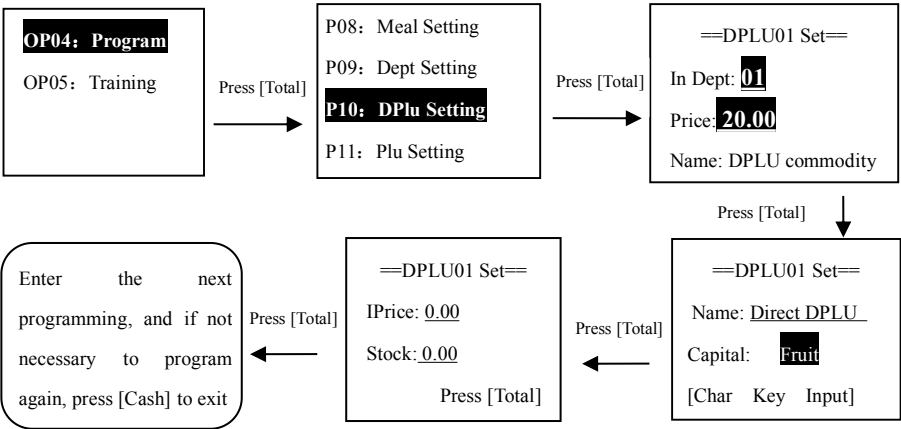

**(Note: the cash register has no setting of [direct commodity] when leaving factory, it is necessary to customize this key. Conduct programming via referring to "Page 20 keyboard custom programming".)**

**(2) DPLU Sales**

Use steps: Press [Cash] and then press [X/Times↑] or [Change Price↓] for selecting an item, and press [Total]

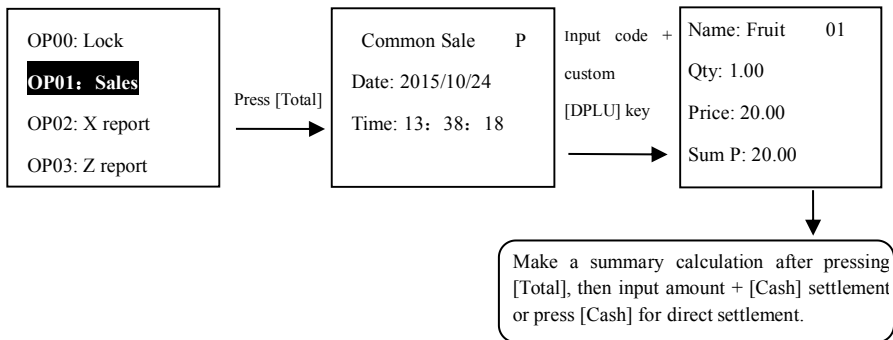

#### 4. Package (Note: the cash register can program at most 20 packages)

The package sale means that a sales operation can sell multiple different categories of commodity. It can be used together with multiple pieces sales, discount and service charge, but can't conduct the temporary price input operation.

##### (1) Package programming

Use steps: Press [Cash] and then press [X/Times↑] or [Change Price↓] for selecting an item, and press [Total]

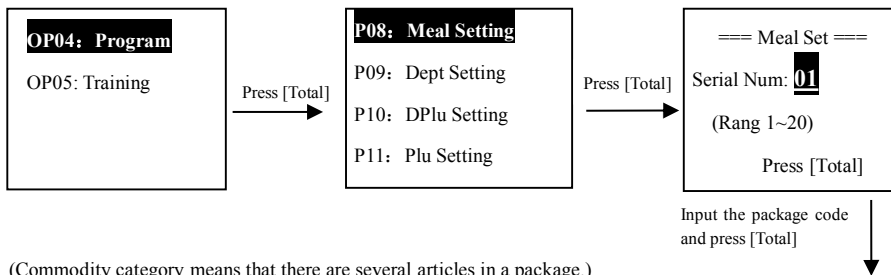

(Commodity category means that there are several articles in a package.)

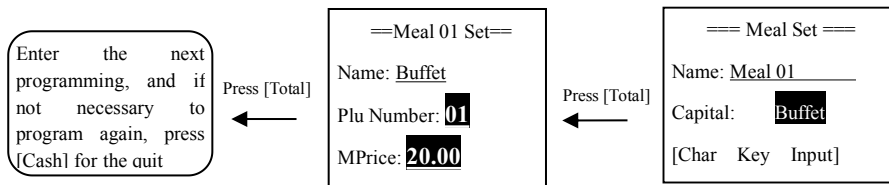

(Note: The commodity PLU data shall have been input in the cash register. The cash register doesn't set up [Package], and sales can be conducted after customizing the [Package]. Conduct programming via referring to the "Page 20 keyboard custom programming".)

##### (2) Package sales

Use steps: Press [Cash] and then press [X/Times↑] or [Change Price↓] for selecting an item, and press [Total]

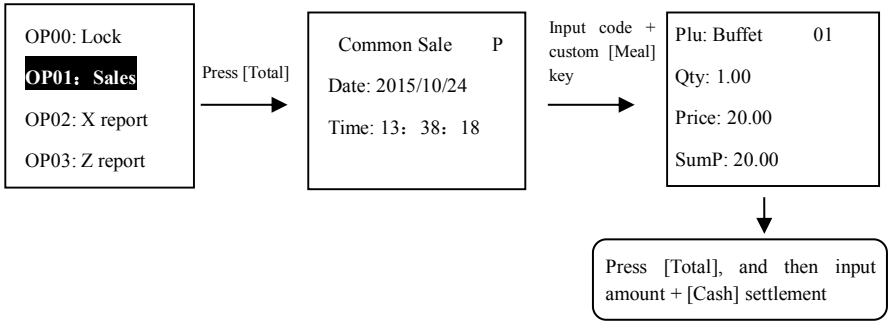

## 5. Checkout Counter (Note: the cash register can find 250 pieces at most.)

Checkout counter sales mean the sales model aiming at the catering industry, and divide the sales according to the checkout counter, facilitating the user's management of the checkout counter records.

### (1) Name of the Table

Use steps: Press [Cash] and then press [X/Times↑] or [Change Price↓] for selecting an item, and press [Total]

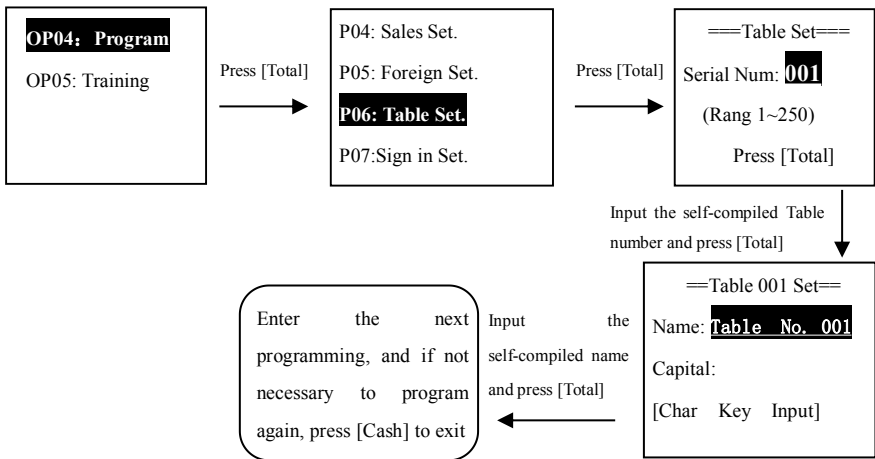

### (2) Table sales

Use steps: Press [Cash] and then press [X/Times↑] or [Change Price↓] for selecting an item, and press [Total]

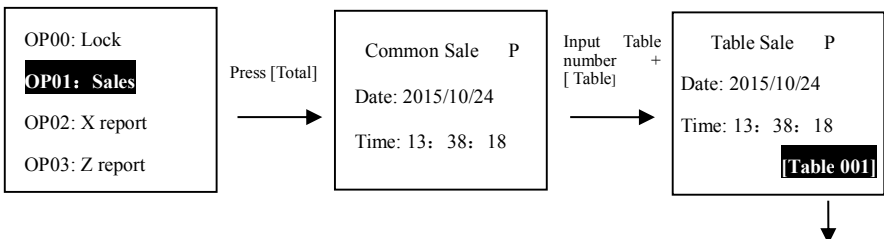

(Continue the unfinished content of last page) ↓

Conduct the commodity sales,  
Dept. sales, direct commodity  
sales and package sales

### (3) Table paused

Use steps: Press [Cash] and then press [X/Times↑] or [Change Price↓] for selecting an item, and press [Total]

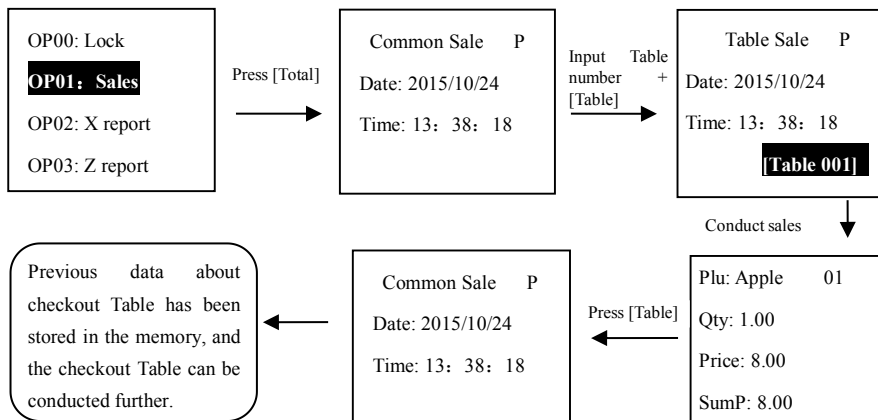

### (4) Table Recovery

Use steps: Press [Cash] and then press [X/Times↑] or [Change Price↓] for selecting an item, and press [Total]

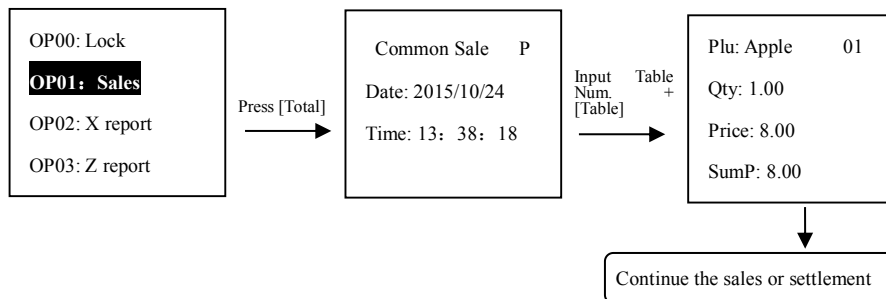

### (5) Table Changed

Use steps: Press [Cash] and then press [X/Times↑] or [Change Price ↓] for selecting an item, and press [Total]

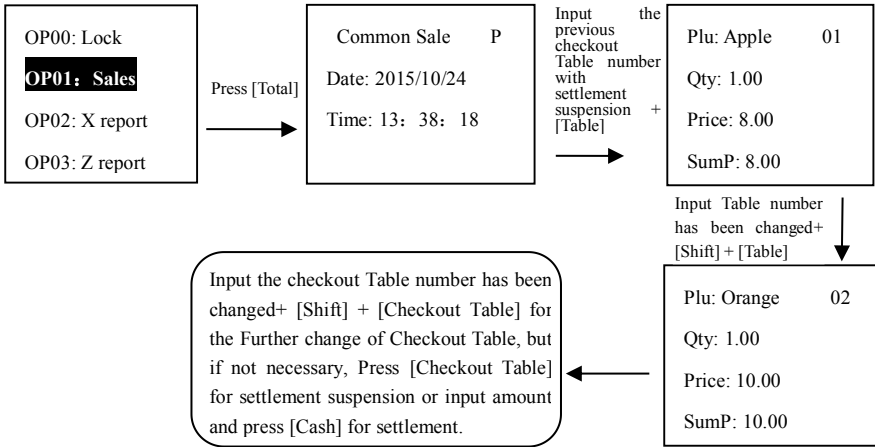

### Checkout Counter combination operation process:

- 1.1 Input: Number 2+ [Shift] + [Checkout Counter], input 2# into the memory, and combine with 1#
- 1.2 Input: Number 3+ [Shift] + [Checkout Counter], input 3# into the memory, and combine with 1#
- 1.3 Repeat 1.2 and 1.3, and input other checkout counter records into the memory
- 1.4 Continue the settlement suspension, discount, increase of service charge and settlement operation

(Note: all the checkout counters have kept the settlement suspension, and change of checkout counter can be made only by transferring one from those under settlement suspension, or a new checkout counter can be opened for transferring the account of the previous one to this one. During the change of the checkout counter, the total number of sales items of combined records shall not exceed 80.)

## 6. Keyboard programming

Use steps: Press [Cash] and then press [X/Times↑] or [Change Price↓] for selecting an item, and press [Total]

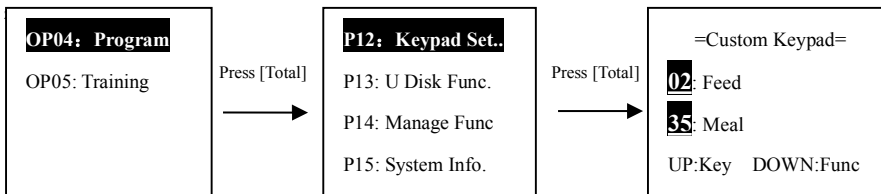

**Note: Up: Keyboard key on the cash register    Down: Custom function key**

### Refer to "Appendix B: Keyboard Custom Key Value Comparison Table" for Programming

For example: Change [Dept 18/36] to [Meal], and input 02+ [Total], the cursor will jump to the next line automatically. If the function key to be customized is [Meal], input 35+ [Total], and after complete the customization, press [Cash] to exit.

# Chapter 4 Member Function

## 1. VIP setting

Use steps: Press [Cash] and then press [X/Times↑] or [Change Price↓] for selecting an item, and press [Total]

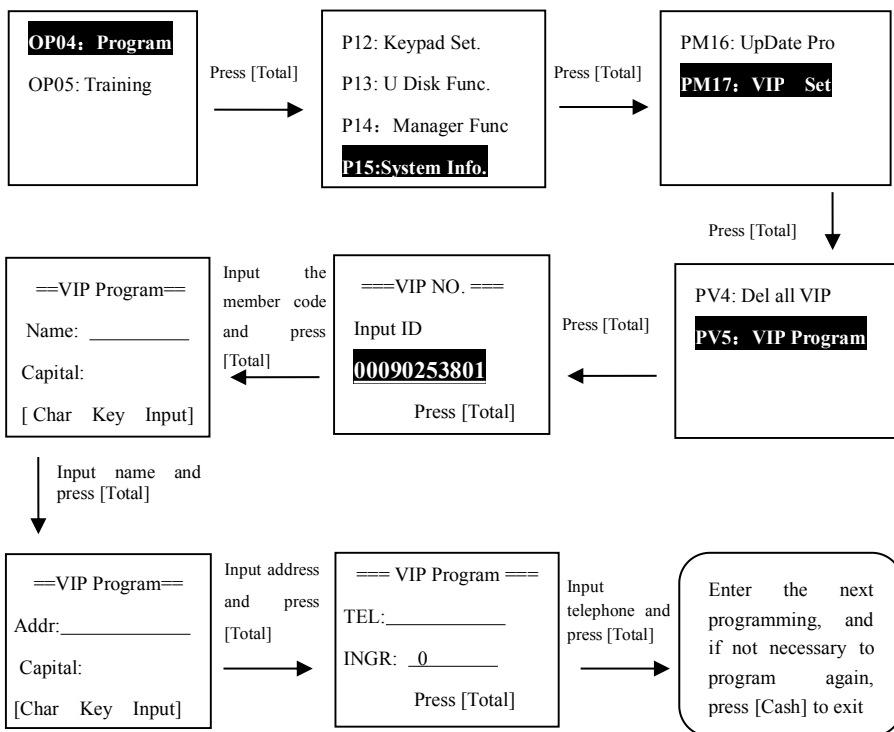

## 2. Rules of VIP Integral

Use steps: Press [Cash] and then press [X/Times↑] or [Change Price↓] for selecting an item, and press [Total]

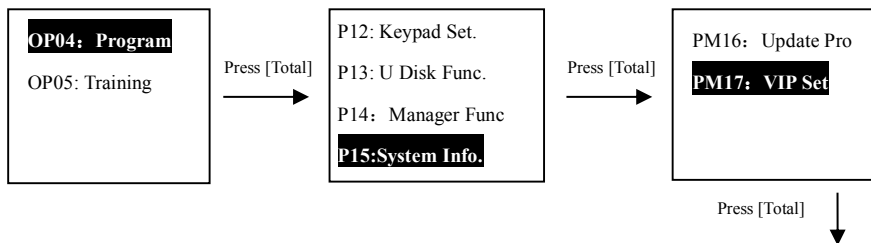

(Continue the unfinished content of last page)

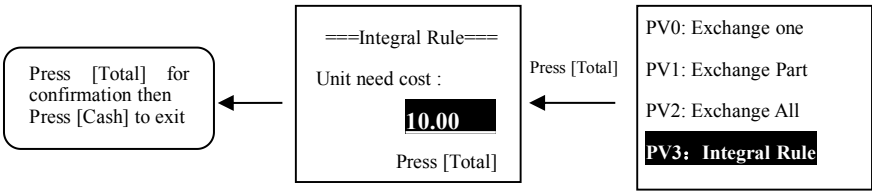

### 3. VIP function commodity (PLU) (use of a cash register with member function)

#### (1) PLU programming

Use steps: Press [Cash] and then press [X/Times↑] or [Change Price↓] for selecting an item, and press [Total]

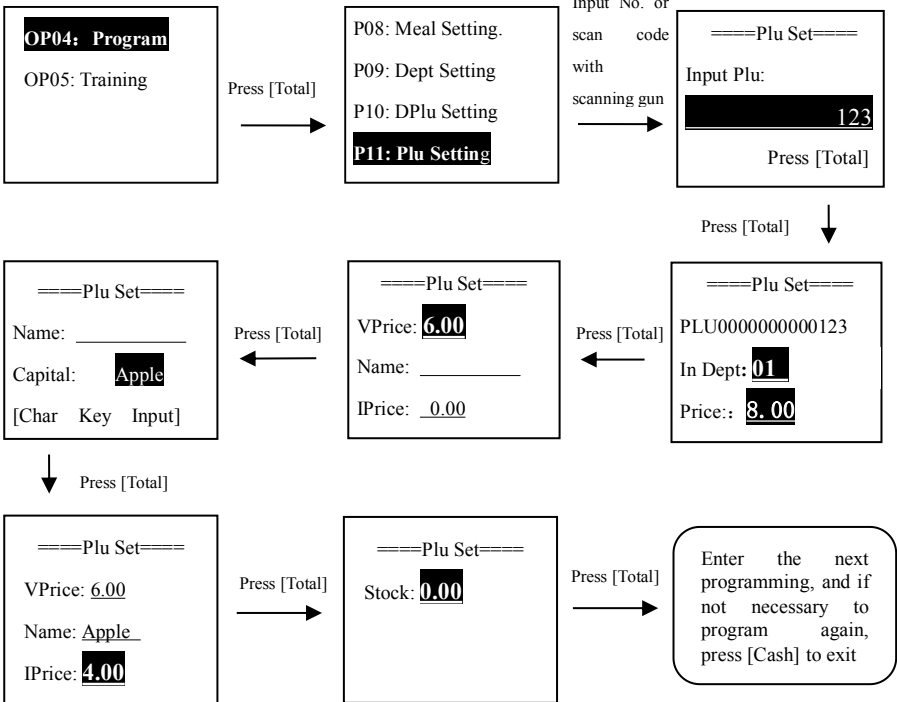

(Note: The category of PLU programming is to classify the commodity. The cash register has no setting of [VIP], it is necessary to customize [VIP] key to provide reference for member sales. Conduct programming via referring to "Page 20 keyboard custom programming".)

**(2) PLU sales**

Use steps: Press [Cash] and then press [X/Times↑] or [Change Price↓] for selecting an item, and press [Total]

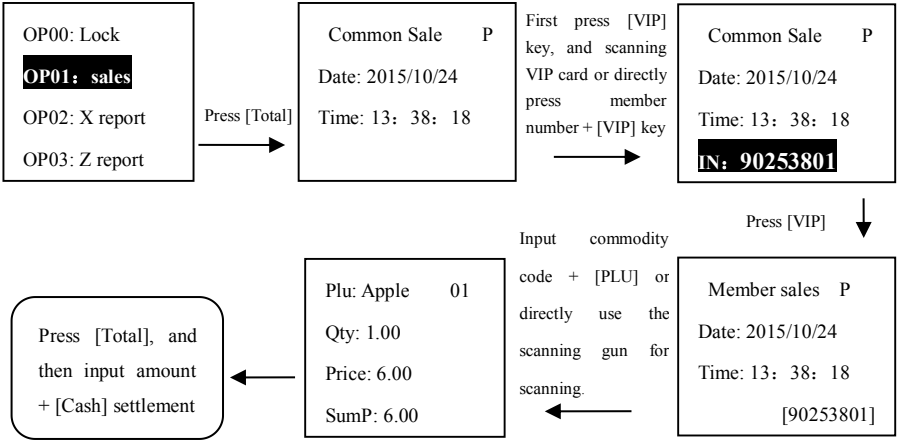

**4. VIP function category (DEPT) (use of cash register with member function)**

**(1) DEPT programming**

Use steps: Press [Cash] and then press [X/Times↑] or [Change Price↓] for selecting an item, and press [Total]

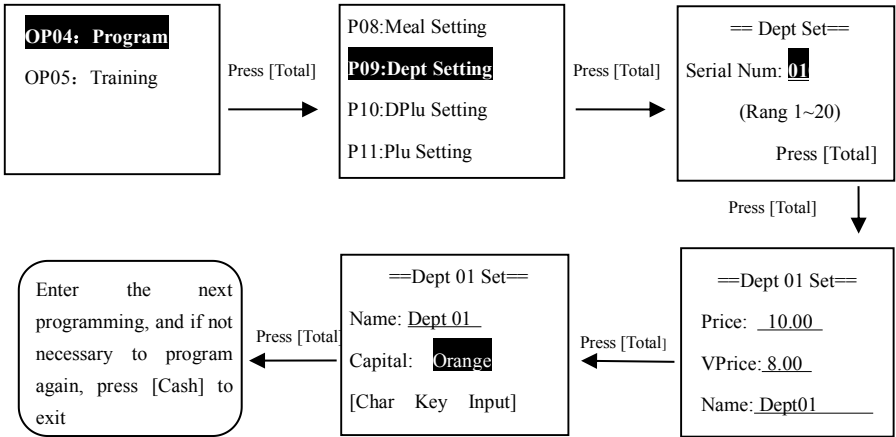

**Notes:** Selection item of the discount is 0-3; such function mainly aims at the operation of overall discount/increase of service charge. In such sales, commodity of different categories can set up the different function value with a factory default value of 0. Function value 0 means that the commodity allows the operation of discount/increase of service charge;

Function value 1 means that the commodity prohibits the discount, but allows the operation of increase of service charge;  
 Function value 2 means that the commodity allows the operation of discount, and prohibits the operation of increase of service charge;  
 Function value 3 means that the commodity doesn't allow the operation of discount/increase of service charge.

**(Note: The cash register has no setting of [Member], it is necessary to customize this key for member sales. Conduct programming via referring to "Page 20 keyboard custom programming".)**

## (2) DEPT Sales

Use steps: Press [Cash] and then press [X/Times↑] or [Change Price↓] for selecting an item, and press [Total]

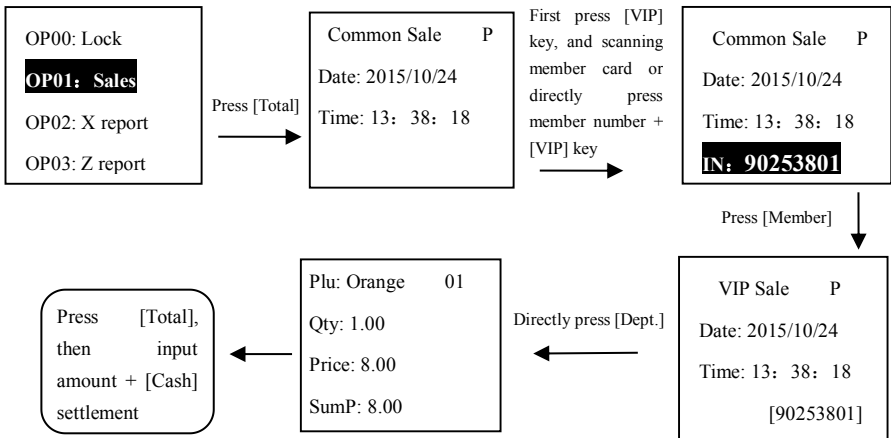

## 5. VIP function direct commodity (DPLU) (use of a cash register with member function)

### (1) DPLU programming

Use steps: Press [Cash] and then press [X/Times↑] or [Change Price↓] for selecting an item, and press [Total]

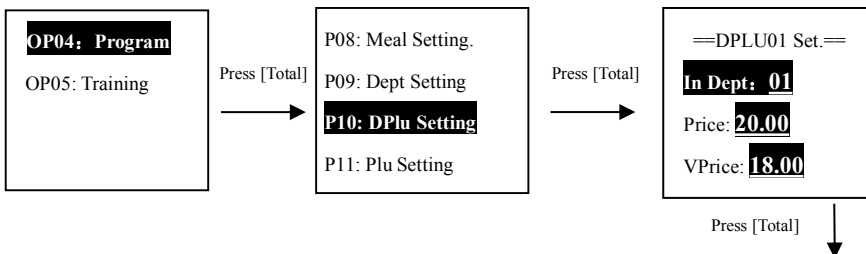

(Continue the unfinished content of last page)

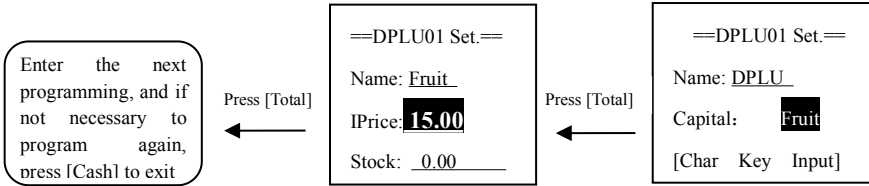

(Note: the cash register has no setting of [Direct DPLU] and [VIP] when leaving factory, it is necessary to customize these two keys. conduct programming via referring to "Page 20 keyboard custom programming".)

## (2) DPLU Sales

Use steps: Press [Cash] and then press [X/Times↑] or [Change Price↓] for selecting an item, and press [Total]

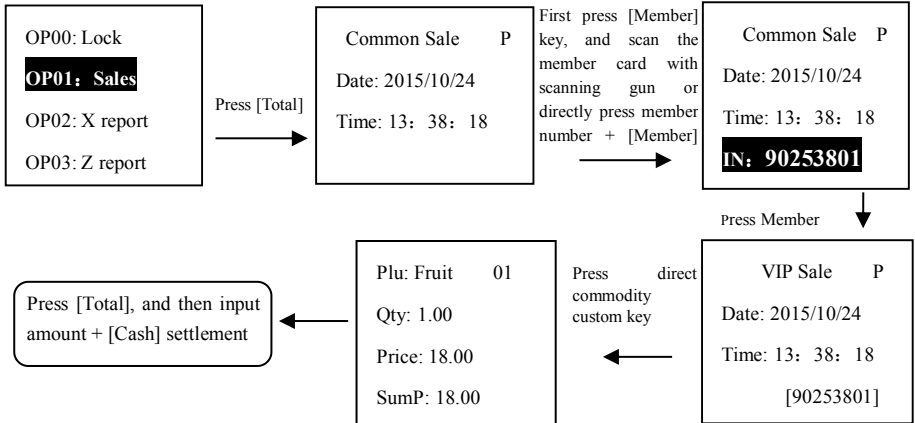

## 6. VIP meal function (use of a cash register with member function)

### (1) Meal programming

Use steps: Press [Cash] and then press [Multiply/Page Up] or [PLU price change/Page Down] for selecting an item, and press [Total]

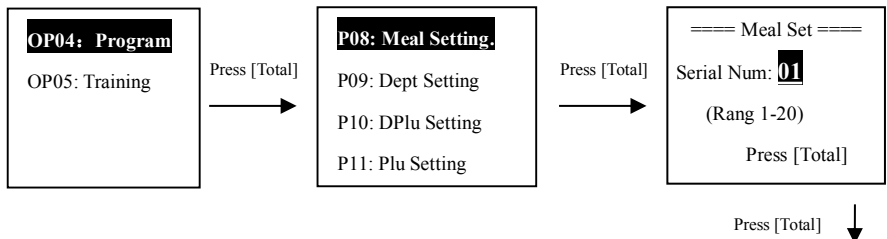

(Continue the unfinished content of last page)

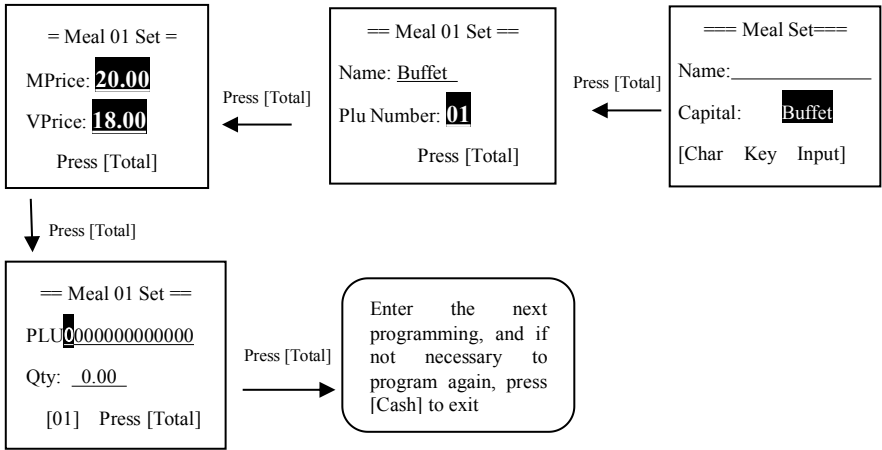

(A PLU number of package programming is the corresponding article of the commodity PLU)

(Note: The cash register has no setting of [Member] and [Package], it is necessary to customize these two key for member sales. Conduct programming via referring to "Page 20 keyboard custom programming".)

## (2) Meal sales

Use steps: Press [Cash] and then press [X/Times↑] or [Change Price↓] for selecting an item, and press [Total]

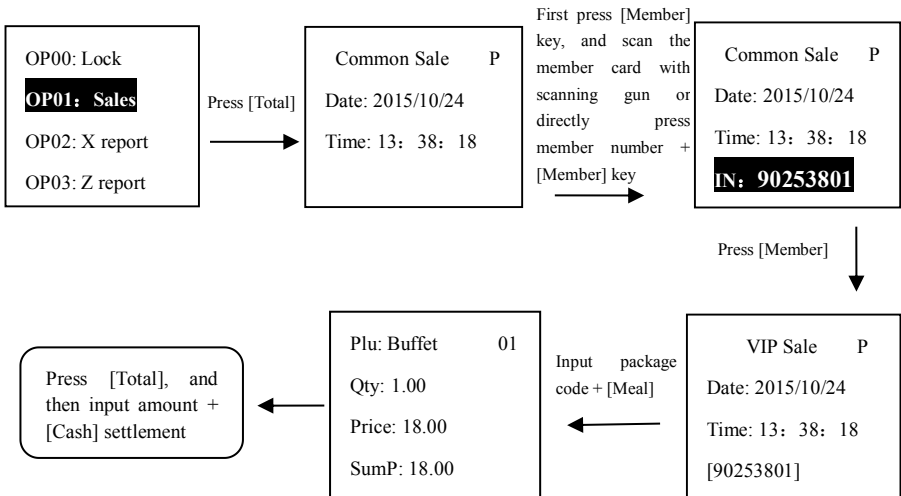

## 7. Operation of member point exchange

Use steps: Press [Cash] and then press [X/Times↑] or [Change Price↓] for selecting an item, and press [Total]

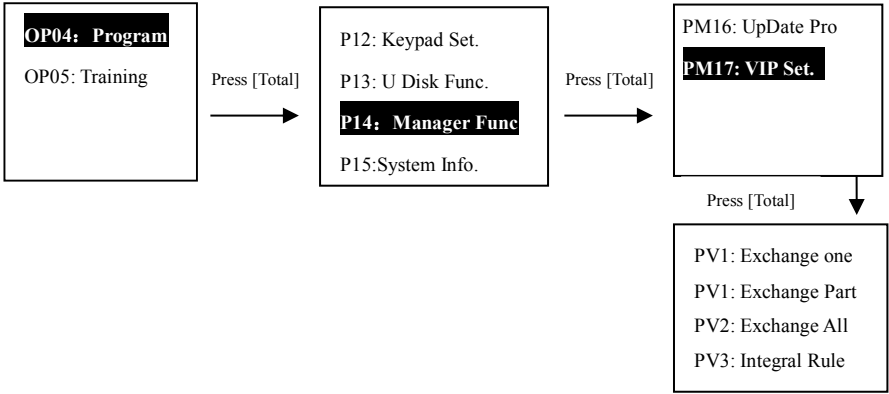

### Exchange with single member:

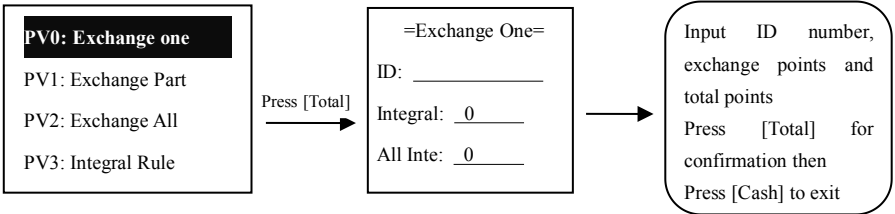

### Exchange with partial members:

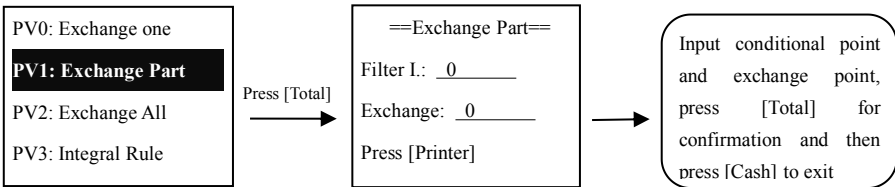

(Note: print the exchange statement in this item. Use steps-press [Print] in this interface for printing.)

### Exchange with all members:

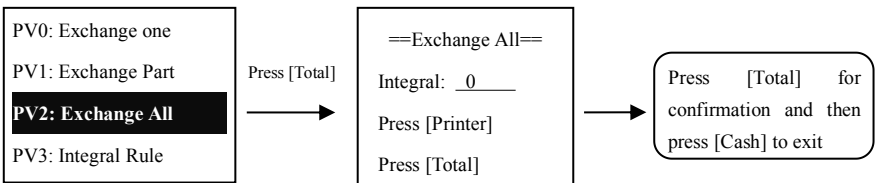

(Note: print member report in this item)

## Chapter 5 Multiple sales methods and settlement methods

### 1. Return

#### (1) Basic return

Use steps: Press [Cash] and then press [X/Times↑] or [Change Price↓] for selecting an item, and press [Total]

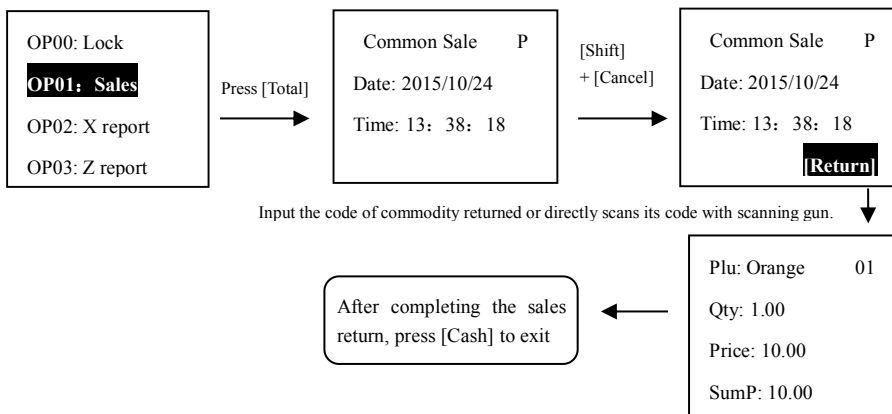

(Note: input the code or category of the commodity to be needed to return. Only 50 orders can be accepted for return. For more orders, clear away the return report data in Z report, and conduct the returns sales.)

#### (2) Password returns

##### (2.1) Password returns programming

Use steps: Press [Cash] and then press [X/Times↑] or [Change Price↓] for selecting an item, and press [Total]

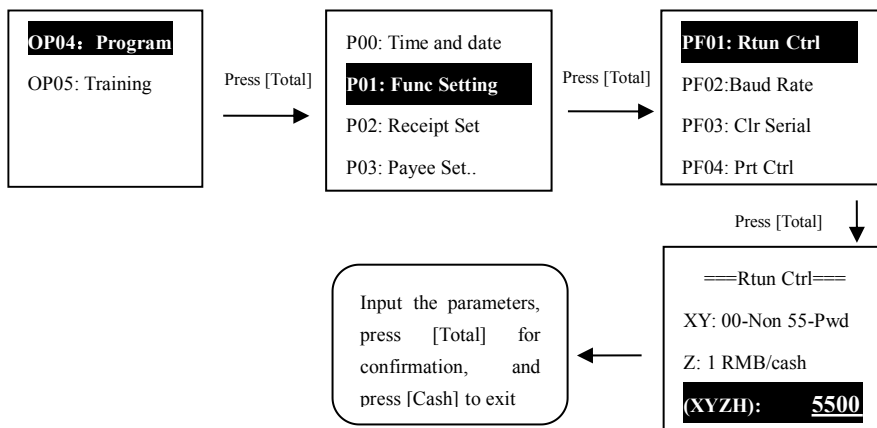

(Note: Password setting function parameter of return sales see the article 1 in Appendix A for programming)

### (2.2) Returns with password

Use steps: Press [Cash] and then press [X/Times↑] or [Change Price↓] for selecting an item, and press [Total]

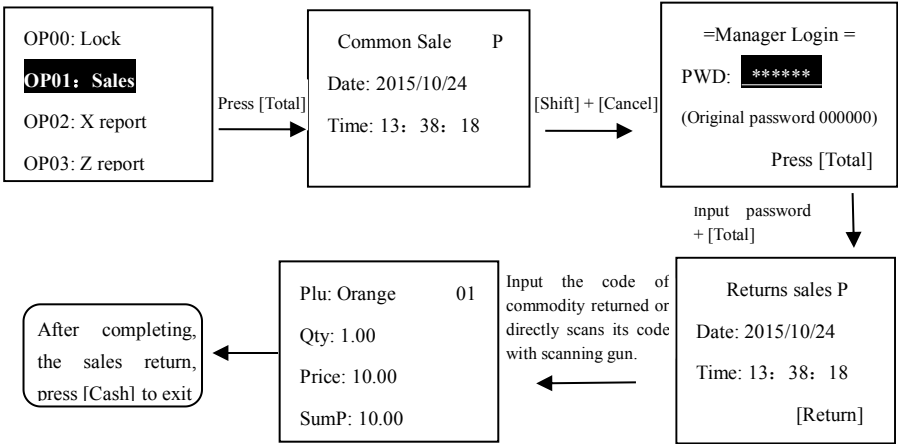

### 2. Multiple pieces sales

Multiple pieces sales mean the input operation of selling multiple same commodities at a time.

Use steps: Press [Cash] and then press [X/Times↑] or [Change Price↓] for selecting an item, and press [Total]

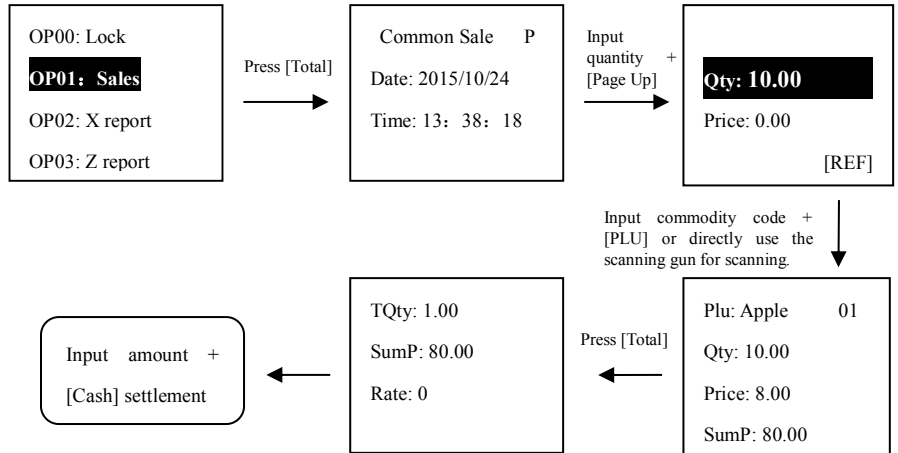

### 3. Sales at variable price

Sales at variable prices mean the operation of having set the unit price of commodity and changing the unit sales price during the sales.

Use steps: Press [Cash] and then press [X/Times↑] or [Change Price↓] for selecting an item, and press [Total]

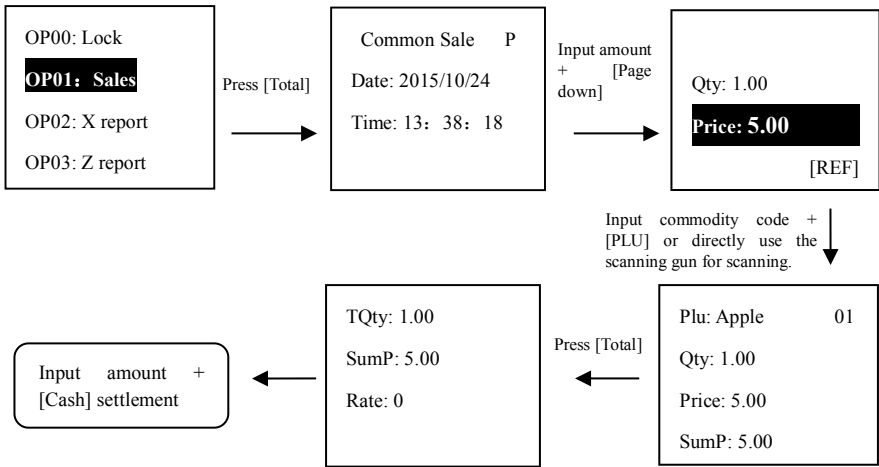

**Usage of category DEPT sales at variable price: Input variable price + [Category]**  
**Usage of direct commodity DPLU sales at variable price: Input variable price + [direct commodity custom key]**

#### 4. A ban on sales at variable prices

A ban on sales at variable prices means that the unit price of commodity has been set, and can't be changed randomly during the sales.

Use steps: Press [Cash] and then press [X/Times↑] or [Change Price↓] for selecting an item, and press [Total]

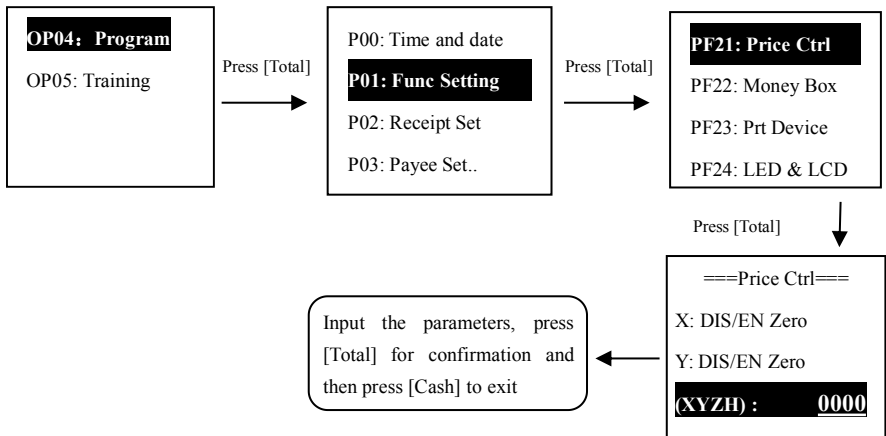

**(Note: Functional parameters of prohibition on sales at variable prices can refer to article 20 in Appendix A for programming.)**

## 5. Electronic barcode scale sales

Use steps: Press [Cash] and then press [X/Times↑] or [Change Price↓] for selecting an item, and press [Total]

### Barcode scale 1:

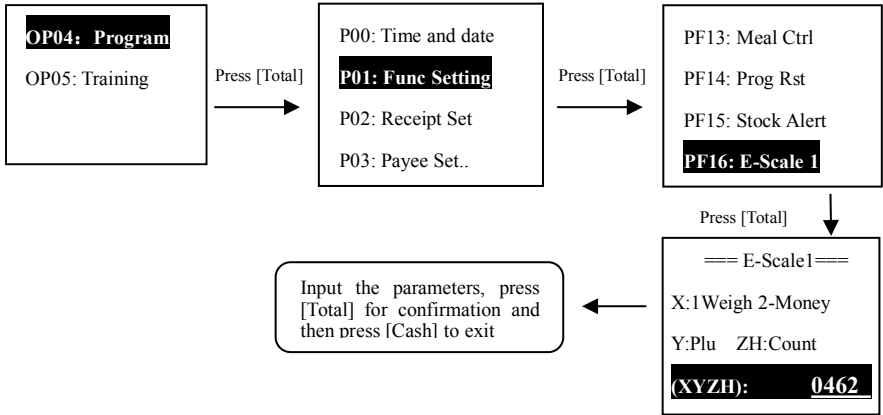

### Barcode scale 2:

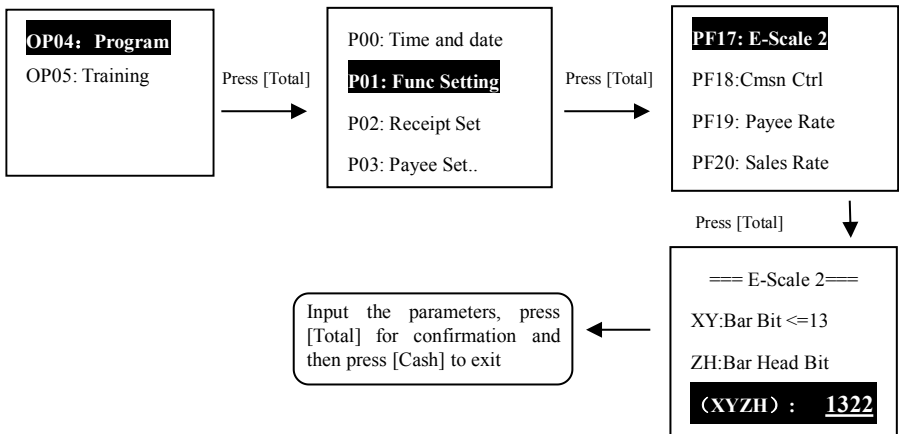

### Barcode diagram of electronic scale:

Total length shall not exceed 13 digits.												
2	3	0	0	0	1	0	2	0	0	3	5	2
Lead code			Plu Setting code				Amount/weight				Check bit	

The electronic barcode scale consists of Lead code + commodity PLU + amount/weight + check code. The entire barcode shall not exceed 13 digits.

Lead code is double-digit, commodity PLU1 is N-digits, amount/weight is 1-N digits, and the check code is double-digit.

Programming of electronic barcode scale refers to Appendix A: System Function Parameter Definition List .The barcode scale of cash register 01 and 02 shall be set up according to the barcode of the electronic barcode scale.

**(Note: setting parameters of electronic barcode scale can refer to Article 15 and 16 of Appendix A for programming.)**

### 6. Settlement at a discount

Commodity discount means the sales of commodities at a discount. It can be divided into single discount and overall discount. Single discount means the discount of the current sales item, and overall discount means the discount of all sale items.

Use steps: Press [Cash] and then press [X/Times↑] or [Change Price↓] for selecting an item, and press [Total]

#### Single discount:

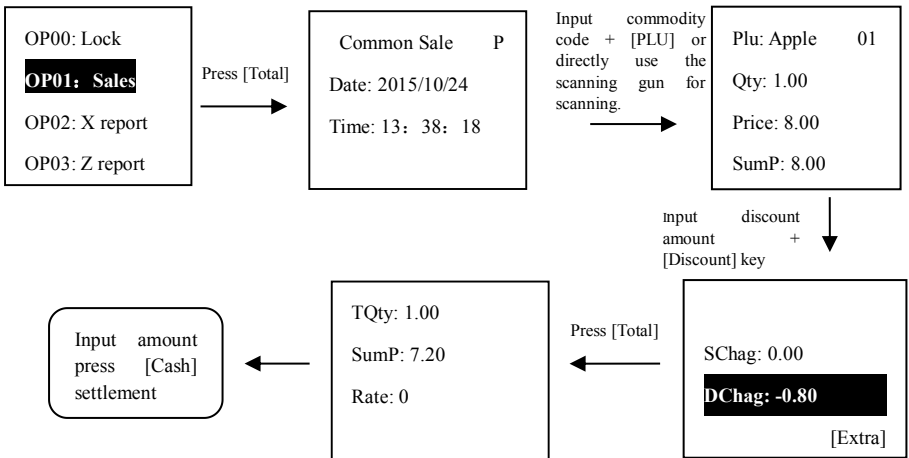

**Overall discount:** All commodities needing discount shall be sold + [Total] + discount amount + [Discount], give discount to all.

**(Note: discount is determined by the percentage. For example, if taking 10% off the price, input 10+ [discount key])**

### 7. Settlement of added service charge

Added service charge is the operation of adding the service charge for the commodity. The single addition of service charge is adding a service charge of the current sales. The overall addition of a service charge is adding a service charge of all sales.

Use steps: Press [Cash] and then press [X/Times↑] or [Change Price↓] for selecting an item, and press [Total]

### Single service charge:

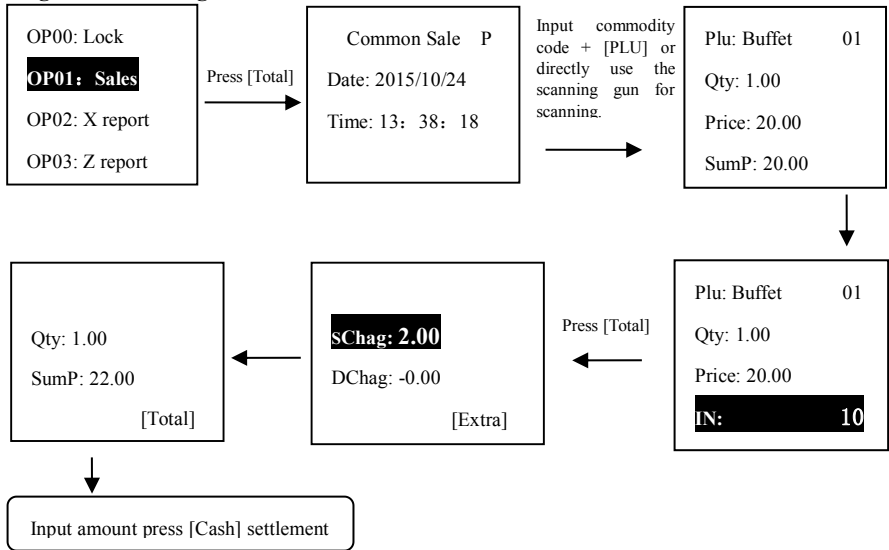

**Overall service charge:** All commodities needing adding service charge shall be sold + [Total] + service charge amount + [service R/A], add the service charge for all.

**(Note: service charge is calculated by the percentage. For example, if adding 10% of the price, input 10+ [service charge])**

### 8. Preferential settlement

Preferential operation means the operation that the user conducts the settlement with the coupon.

Use steps: Press [Cash] and then press [X/Times↑] or [Change Price↓] for selecting an item, and press [Total]

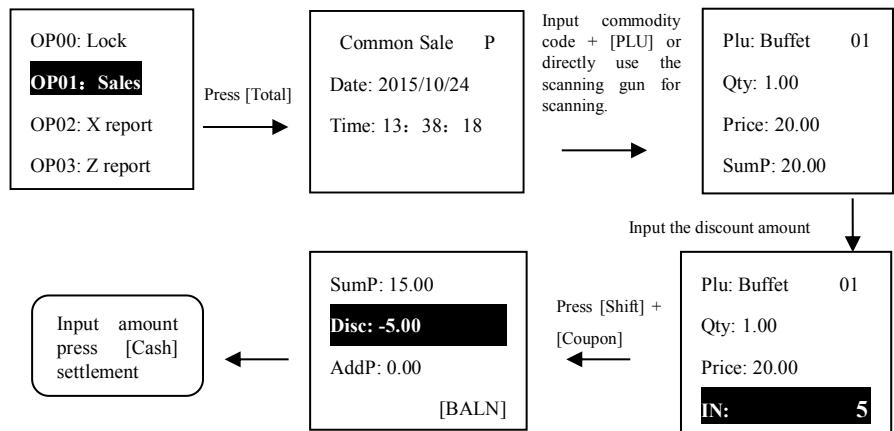

(Note: Preferential operation is a kind of settlement method. After such operation, the settlement can only be made, rather than the operation of sales item. Preferential key and discount key are set up on the same key, therefore, during the preferential sales, change [Shift] should be added for preferential sales.)

### 9. Remove mantissa for settlement

Operation of removing mantissa means the operation of rounding the radix point of the sales.

Use steps: Press [Cash] and then press [X/Times↑] or [Change Price↓] for selecting an item, and press [Total]

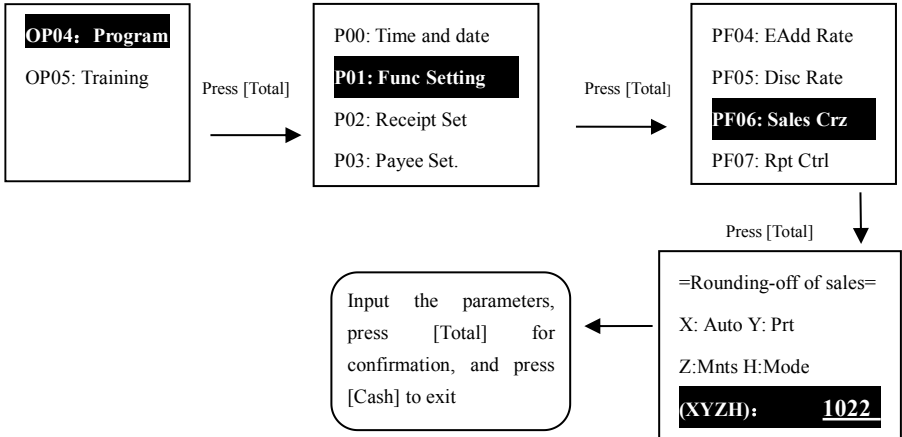

(Note: Artificial mantissa removal shall be effective after the setting. Setting of functional parameters can refer to the article 6 of Appendix A for programming.)

### 10. Cash settlement and change

Cash settlement means the way of the consumer conducting the settlement with cash.

Use steps: Press [Cash] and then press [X/Times↑] or [Change Price↓] for selecting an item, and press [Total]

(Note: during the settlement for commodity sales, only "cash" can be used for settlement.)

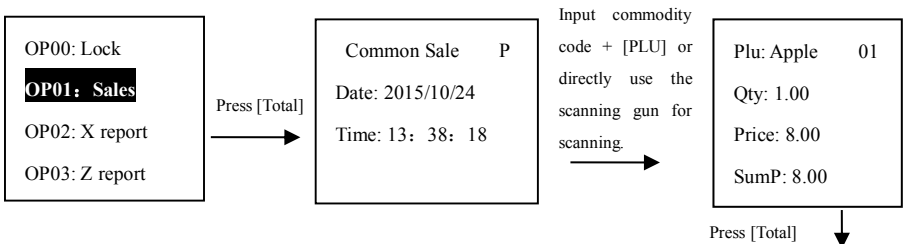

(Continue the unfinished content of last page)

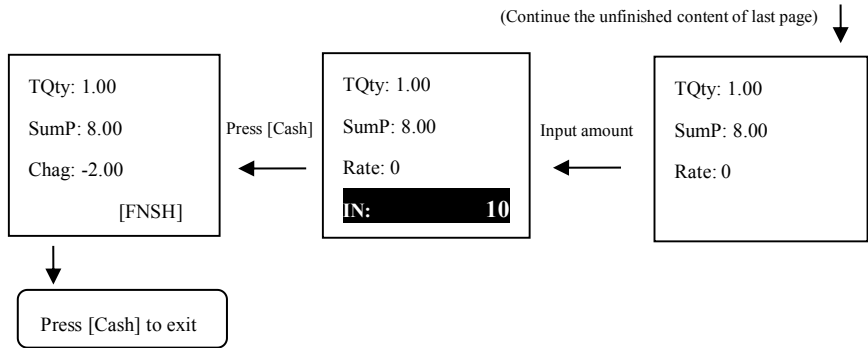

### 11. Credit card settlement

The credit card settlement means the operation that the users conduct the settlement with a credit card.

Use steps: Press [Cash] and then press [X/Times↑] or [Change Price↓] for selecting an item, and press [Total]

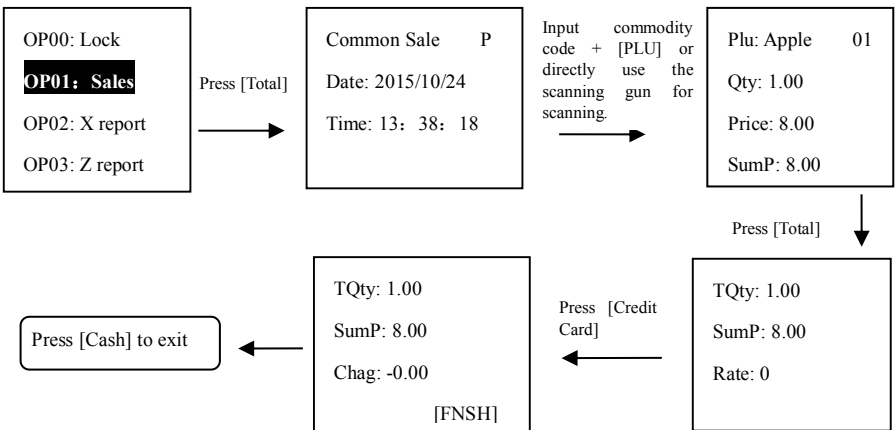

(Note: [Credit Card] is not set up on the keyboard of cash register, so it is needed to customize for credit card settlement. Conduct programming via referring to "Page 16 keyboard custom" for programming".)

### 12. Foreign exchange (Note: the cash register can program at most 8 kinds of foreign exchange)

Foreign exchange settlement means the operation that the consumer conducts the settlement with foreign currency.

#### (1) Foreign exchange programming

Use steps: Press [Cash] and then press [X/Times↑] or [Change Price↓] for selecting an item, and press [Total]

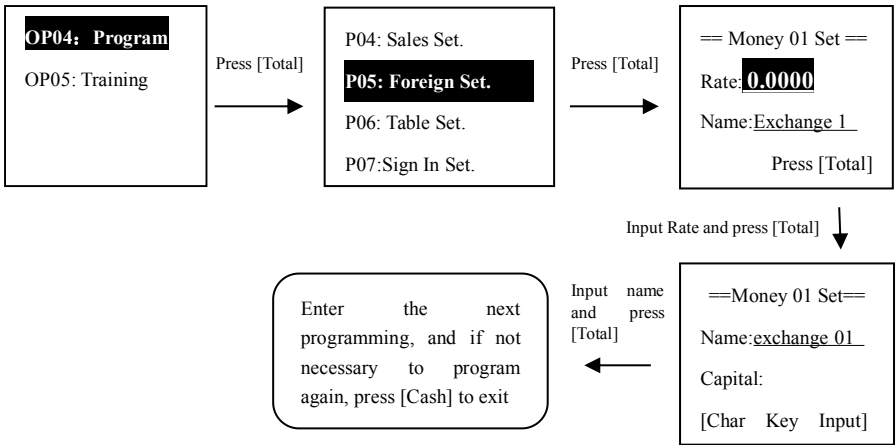

(Note: the keyboard of cash register only sets up a [Foreign Exchange]. If need to use multiple [Foreign Exchange], customize [Foreign Exchange]. Conduct programming via referring to "Page 16 keyboard custom programming".)

## (2) Foreign exchange settlement

Use steps: Press [Cash] and then press [X/Times↑] or [Change Price↓] for selecting an item, and press [Total]

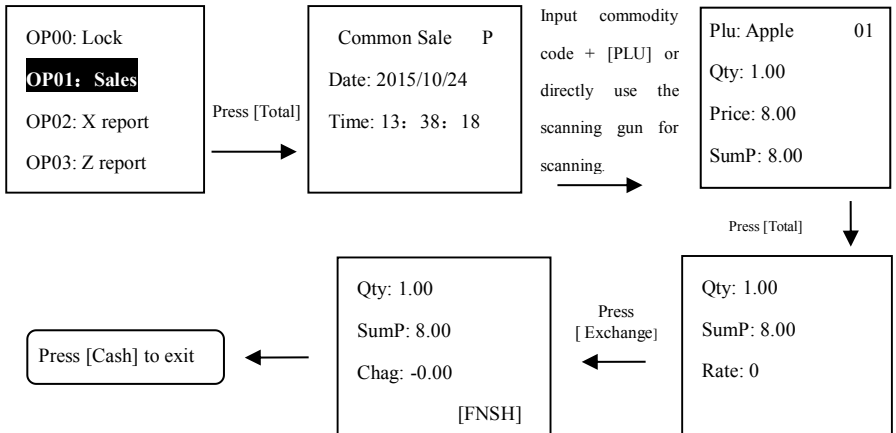

## 13. Signing (Note: the cash register can only set up 50 bill signing customers)

Signing settlement means the operation mode that the consumer conducts the settlement by keeping account.

### (1) Signing programming

Use steps: Press [Cash] and then press [X/Times↑] or [Change Price↓] for selecting an item, and press [Total]

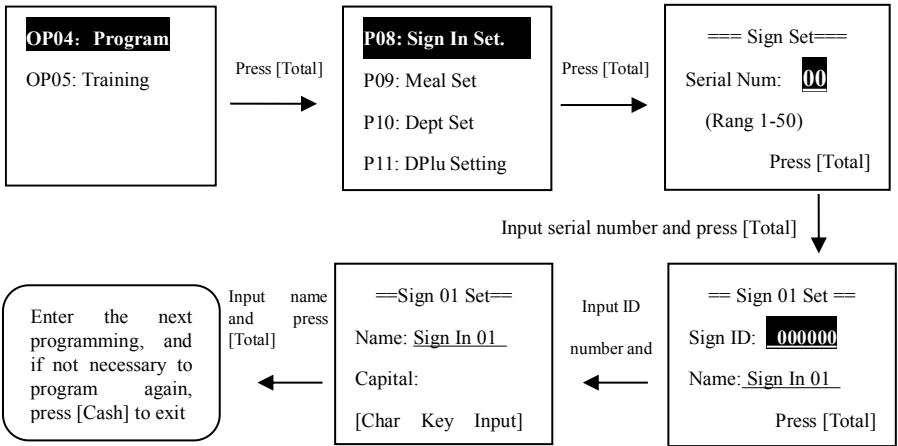

## (2) Signing settlement

Use steps: Press [Cash] and then press [X/Times↑] or [Change Price↓] for selecting an item, and press [Total]

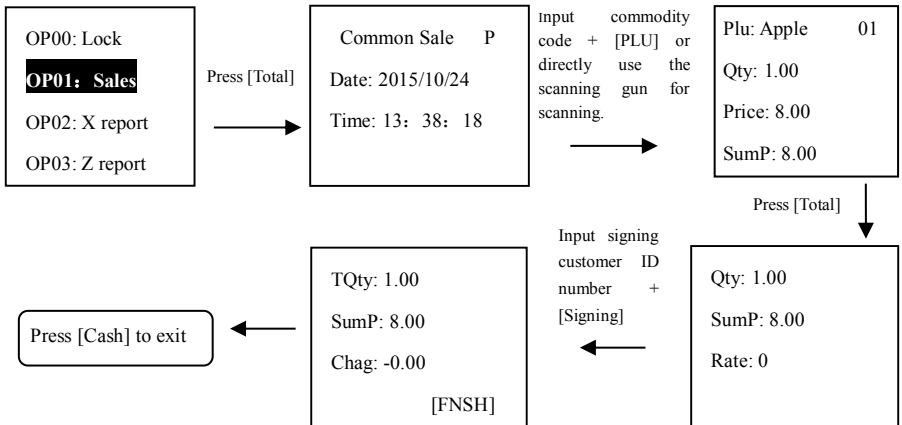

## 14. Unified adding-taxes

Use steps: Press [Cash] and then press [X/Times↑] or [Change Price↓] for selecting an item, and press [Total]

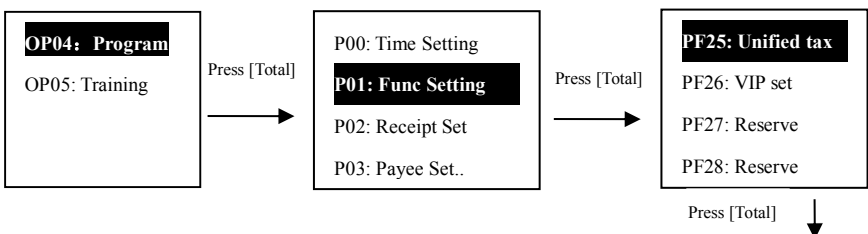

(Continue the unfinished content of last page) ↓

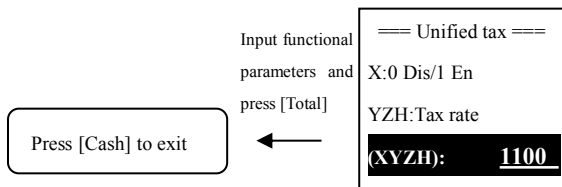

(Note: functional parameters of unified adding-taxes setting can refer to article 24 in Appendix A for programming.)

### 15. Member setting

Use steps: Press [Cash] and then press [X/Times↑] or [Change Price↓] for selecting an item, and press [Total]

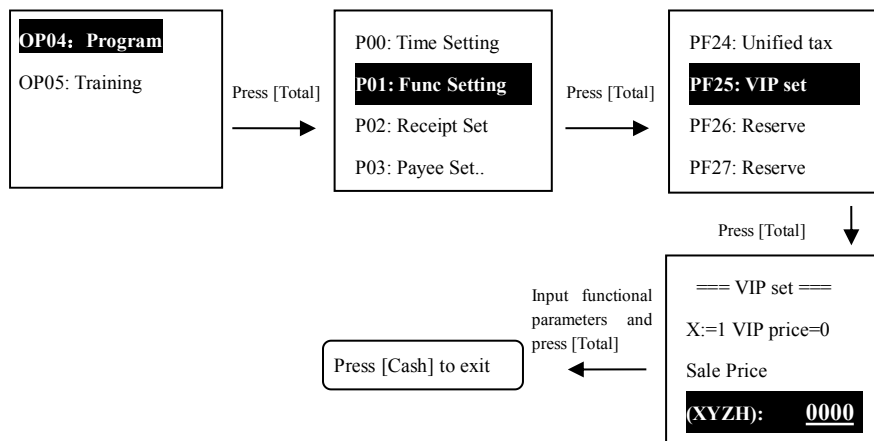

(Note: functional parameters of member setting can refer to article 25 in Appendix A for programming. When using this item, the member price shall be zero. This item can only be applicable to the cash register with member function.)

# Chapter 6 Personnel Management and Password Setting

## 1. Cashier (Note: at most 10 cashiers can only be programmed.)

The operation of cashier setting means the change of current cashier. The sales data after the setting shall be recorded in the name of the cashier newly set.

### (1) Cashier programming

Use steps: Press [Cash] and then press [X/Times↑] or [Change Price↓] for selecting an item, and press [Total]

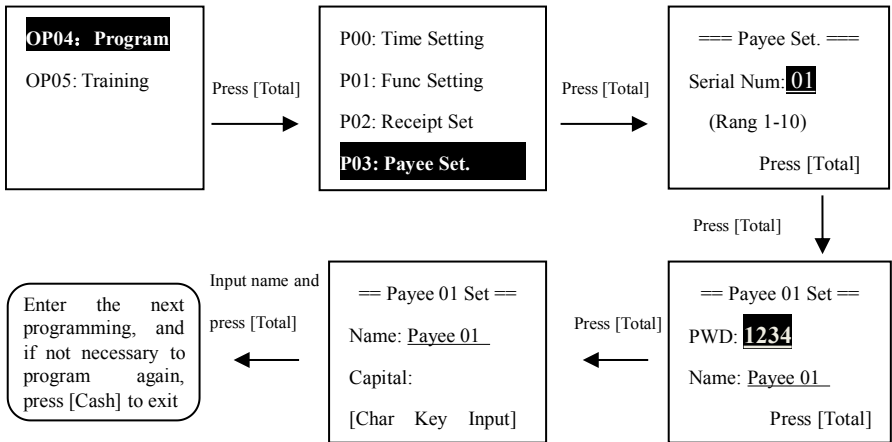

### (2) Cashier use

Use steps: Press [Cash] and then press [X/Times↑] or [Change Price↓] for selecting an item, and press [Total]

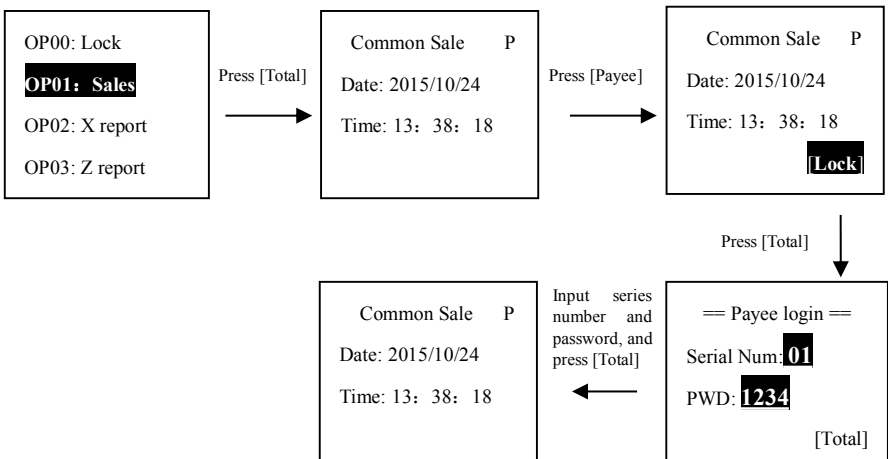

## 2. Shop assistant (Note: at most 50 shop assistants can be programmed.)

The operation of shop assistant setting means the change of current shop assistant. The sales data after the setting shall be recorded in the name of the shop assistant newly set.

### (1) Shop assistant programming

Use steps: Press [Cash] and then press [X/Times↑] or [Change Price↓] for selecting an item, and press [Total]

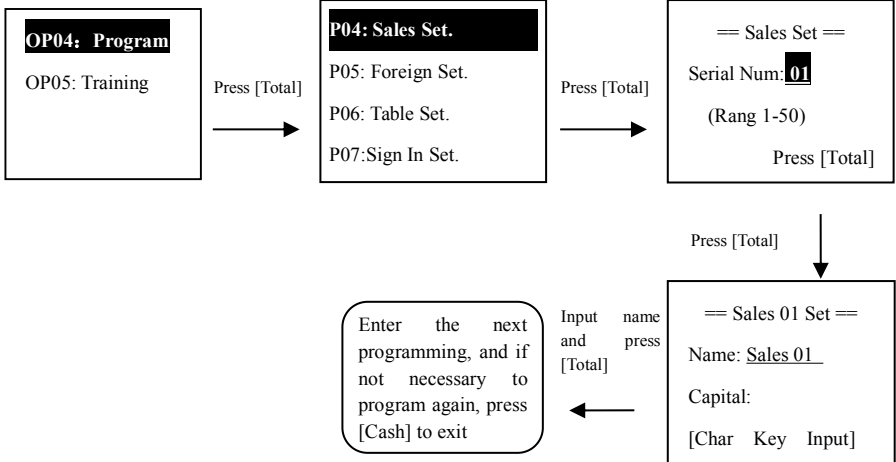

### (2) Shop assistant use

Use steps: Press [Cash] and then press [X/Times↑] or [Change Price↓] for selecting an item, and press [Total]

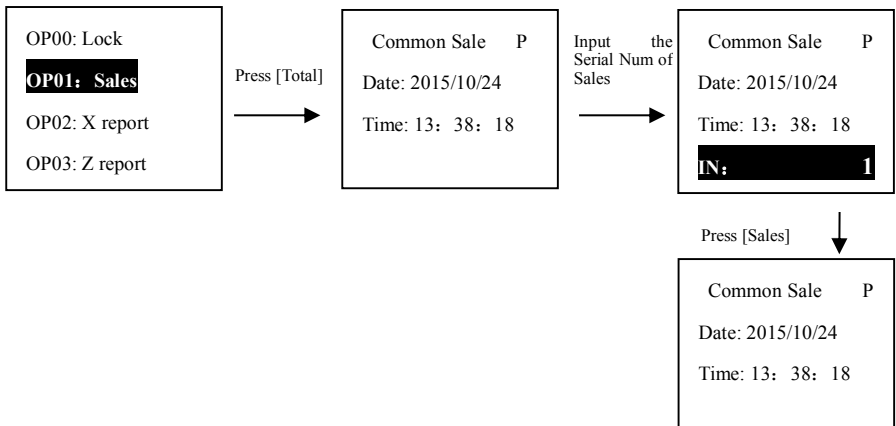

## 3. Lock and unlock

Use steps: Press [Cash] and then press [X/Times↑] or [Change Price↓] for selecting an item, and press [Total]

### Lock:

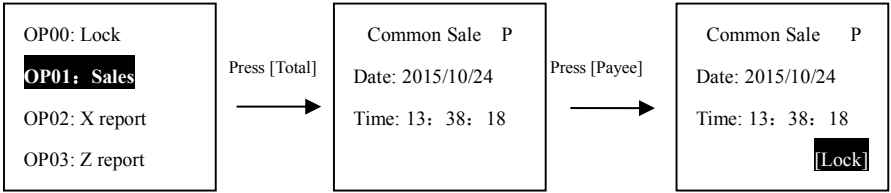

### Unlock:

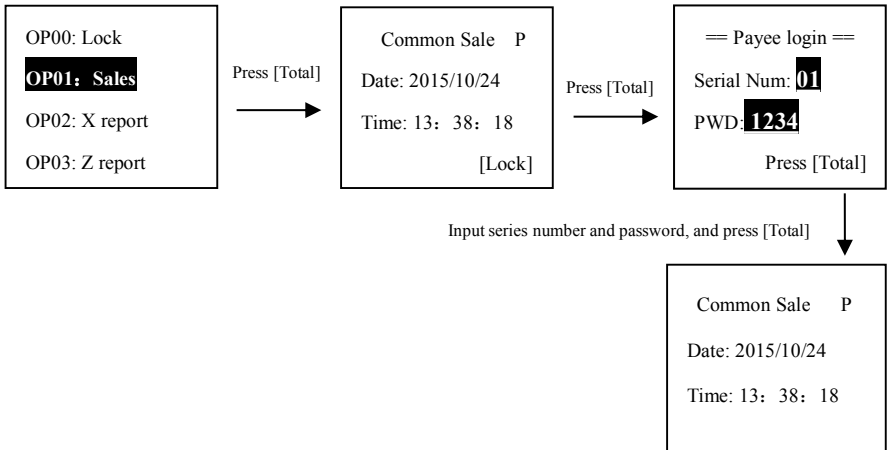

# Chapter 7 Manager Management

## 1. Delete single programming

Use steps: Press [Cash] and then press [X/Times↑] or [Change Price↓] for selecting an item, and press [Total]

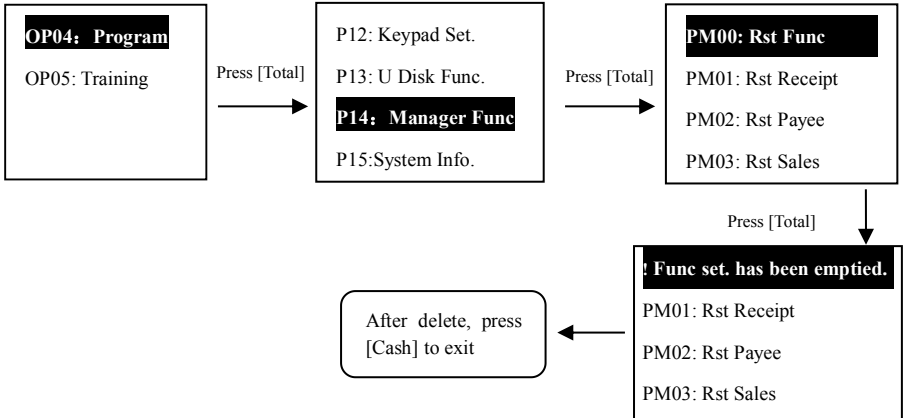

## 2. Delete all programming

Use steps: Press [Cash] and then press [X/Times↑] or [Change Price↓] for selecting an item, and press [Total]

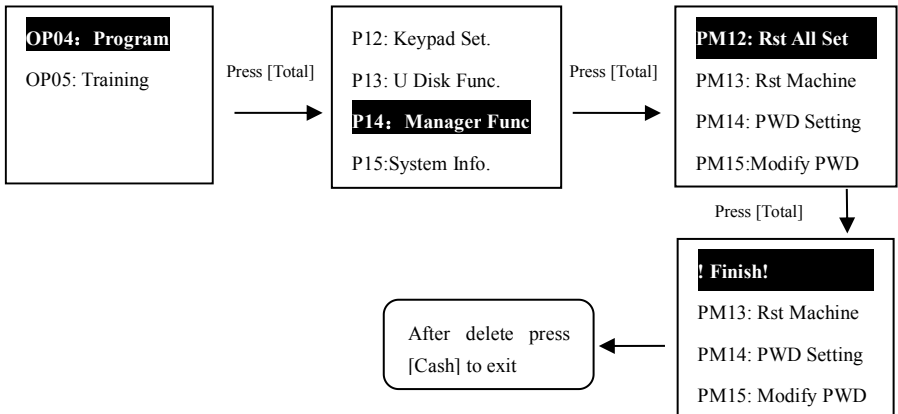

## 3. Recovery of factory settings

**(Warning: all clear operation is irreversible (namely, it is unable to recover after the operation), please be careful to use it.)**

Use steps: Press [Cash] and then press [X/Times↑] or [Change Price↓] for selecting an item, and press [Total]



(Continue the unfinished content of last page) ↓

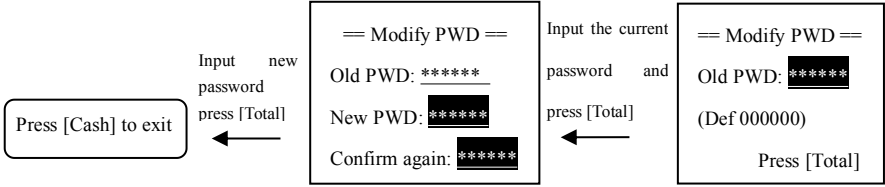

(Note: before changing the password, first input the current password, then input the new password, and confirms the new password again.)

### 6. Cancel the use of manager password

Use steps: Press [Cash] and then press [X/Times↑] or [Change Price↓] for selecting an item, and press [Total]

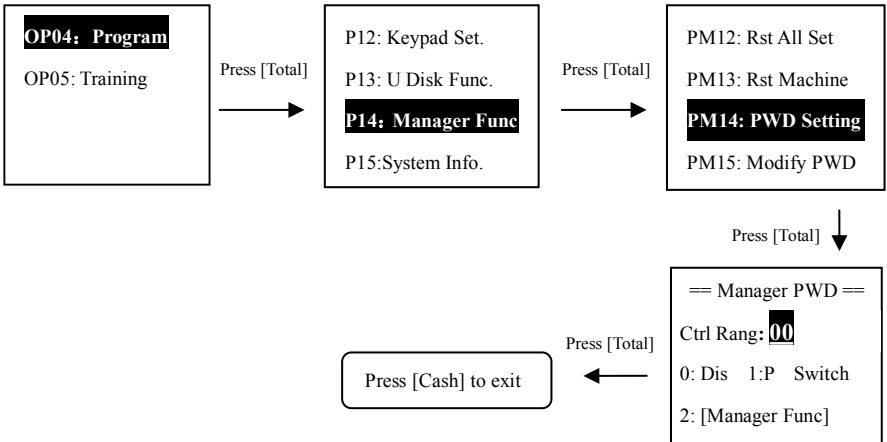

# Chapter 8 Self-testing of Cash Registers

## 1. Full test

Full test means the self-check of cash register.

Use steps: Press [Cash] and then press [X/Times↑] or [Change Price↓] for selecting an item, and press [Total]

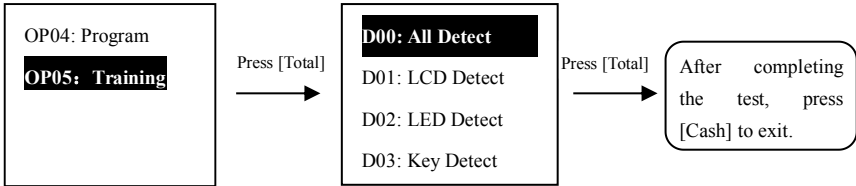

## 2. Main display screen test

The main display screen test means conducting the test of the main screen of the cash register.

Use steps: Press [Cash] and then press [X/Times↑] or [Change Price↓] for selecting an item, and press [Total]

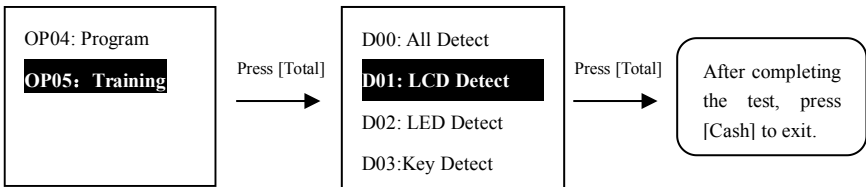

## 3. Customer display screen test

The second display screen test means conducting the test of the second display screen of the cash register.

Use steps: Press [Cash] and then press [X/Times↑] or [Change Price↓] for selecting an item, and press [Total]

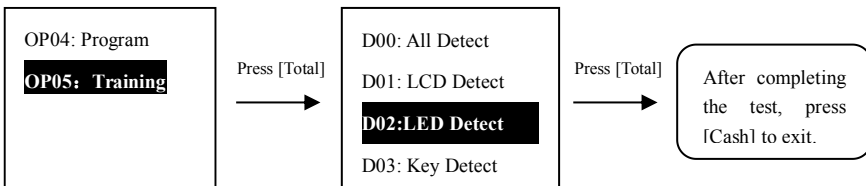

## 4. Keyboard test

Keyboard test means conducting the test on 40 keys of the keyboard of the cash register.

Use steps: Press [Cash] and then press [X/Times↑] or [Change Price↓] for selecting an item, and press [Total]

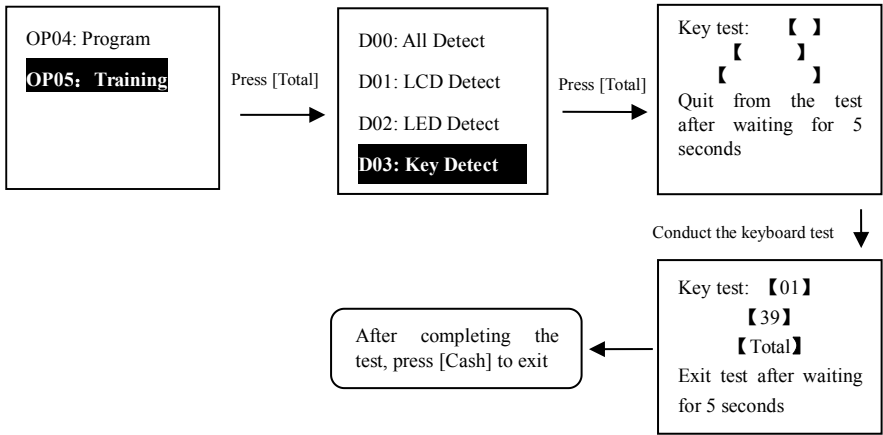

### 5. Print test

Print test means conducting the test on the printing function of the cash register.

Use steps: Press [Cash] and then press [X/Times↑] or [Change Price↓] for selecting an item, and press [Total]

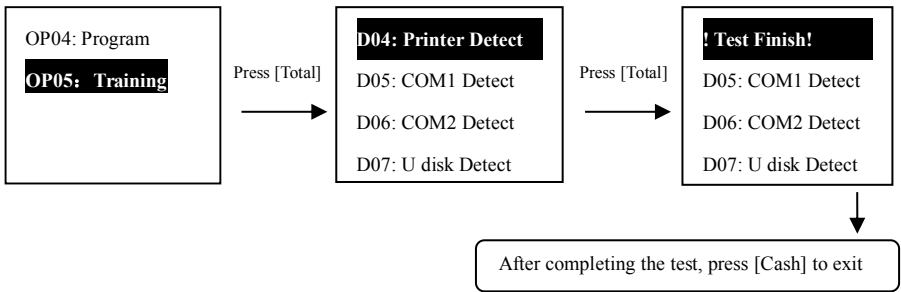

### 6. COM1 test

COM1 test means conducting the test on whether the communication port of the cash register can be connected with the computer. (The communication port can be connected with the barcode port with a serial port line for the test, and then can be tested.)

Use steps: Press [Cash] and then press [X/Times↑] or [Change Price↓] for selecting an item, and press [Total]

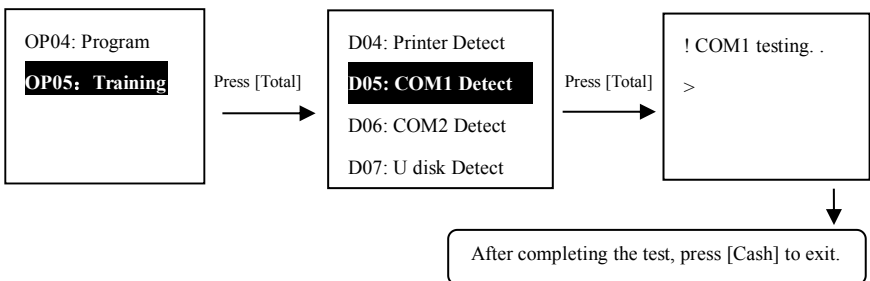

### 7. COM2 test

COM2 test means conducting the test on whether the barcode port cash register can be connected with the barcode port. (The communication port can be connected with the barcode port with a serial port line for the test, and then can be tested.)

Use steps: Press [Cash] and then press [X/Times↑] or [Change Price↓] for selecting an item, and press [Total]

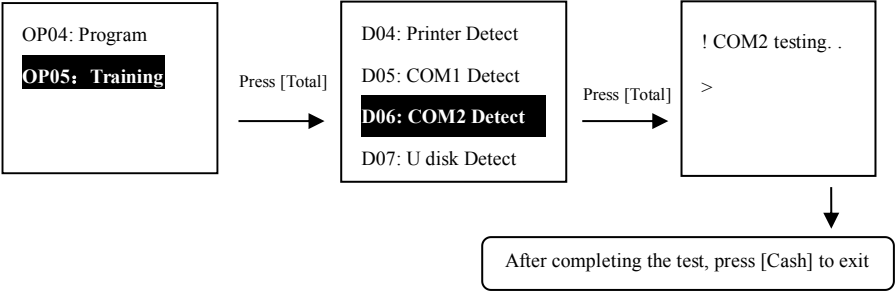

### 8. USB flash disk test

The USB flash disk test is testing whether the USB flash disk can download or upload data.

Use steps: Press [Cash] and then press [X/Times↑] or [Change Price↓] for selecting an item, and press [Total]

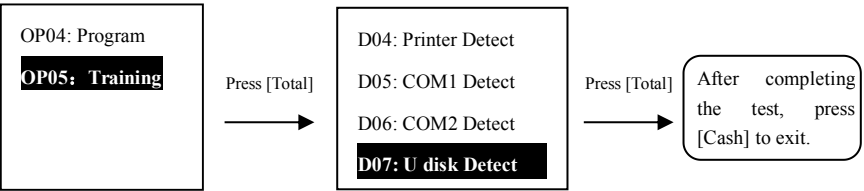

### 9. Cash box test

Cash box test is testing whether cash box can be popped up normally.

Use steps: Press [Cash] and then press [X/Times↑] or [Change Price↓] for selecting an item, and press [Total]

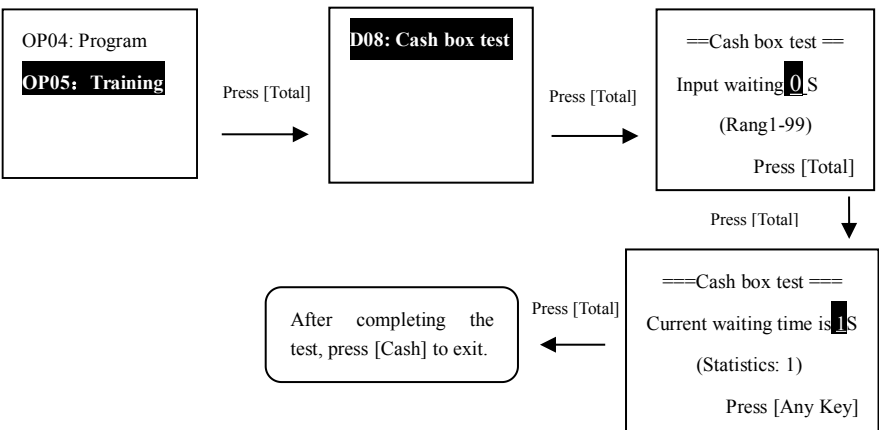





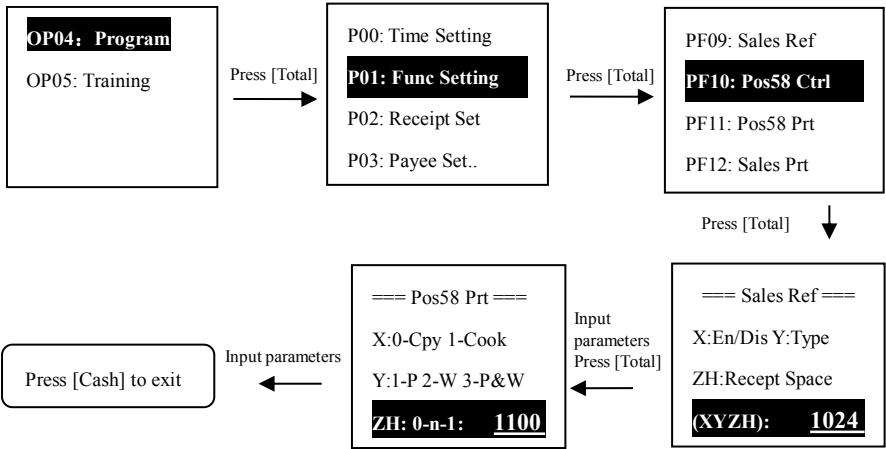

(Note: The setting of functional parameters can refer to article 10 in Appendix A for programming.)

**5. Communication port is connected with price computing scales**(use serial port 232 for connection, and insert serial port 232 data lines into the "communication port" of the cash register.)

Use steps: Press [Cash] and then press [X/Times↑] or [Change Price↓] for selecting an item, and press [Total]

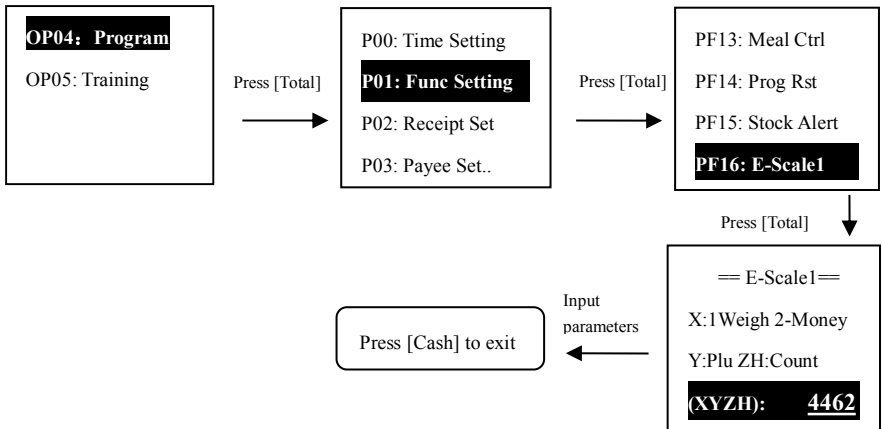

(Note: setting of functional parameters can refer to the article 15 in Appendix A for programming. The cash register doesn't set up the [Electronic Scale] key, so it is necessary to customize [Electronic Scale] key for using the electronic scale sales. Refer to "Page 16 keyboard custom programming" for programming; during the sales, directly press the [Electronic Scale] key. )

**6. Barcode port is connected with POS (use serial port 232 for connection, and insert serial port 232 data lines into the "barcode port" of the cash register.)**

**(Note: When need to use two sets of POS, functional parameters can be set via referring to the article 10 in Appendix A for programming.)**

Use steps: Press [Cash] and then press [X/Times↑] or [Change Price↓] for selecting an item, and press [Total]

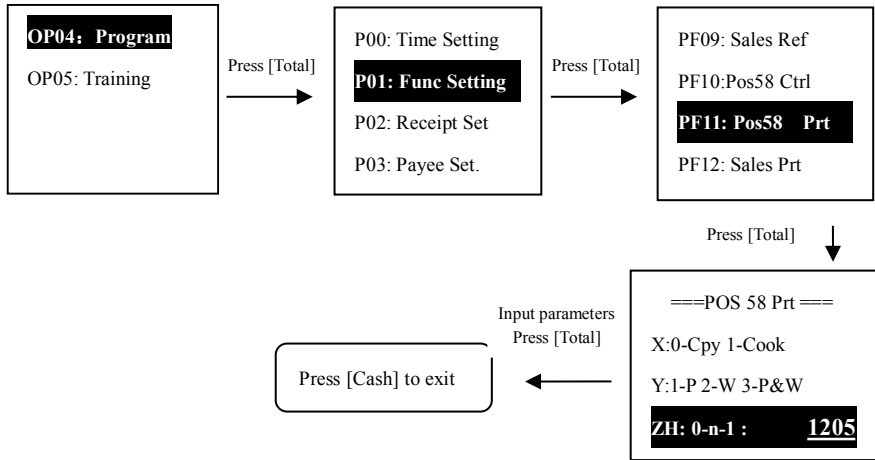

When using two sets of POS for printing, for commodity PLU sales, first enter the category of PLU programming commodity (sales by category doesn't need programming). As the parameter set up in the article 10 is 1205, the category of commodity PLU1 is set as 1, and the category of commodity PLU2 is set as 6, so POS1 prints the commodity 1 and POS2 prints the commodity 2; 5 is a point of division, with those before 5 (including 5) printed by POS1 and those after 5 printed by POS2.

**7. Connect barcode port to barcode gun**

- 1) The data line of barcode gun must be connected with the "barcode port" of the cash register; the communication interface of the barcode gun shall be RS-232 interface;
- 2) The barcode is set as the factory default (namely: 9600 bps, 8 data bits, without check bit);
- 3) Conduct the setting according to the manual of barcode gun.

## Chapter 10 Sales Pretreatment

### 1. Sales of commodity font size in the receipt (Note: font size refers to the article 11 of Appendix A for setting).

Use steps: Press [Cash] and then press [X/Times↑] or [Change Price↓] for selecting an item, and press [Total]

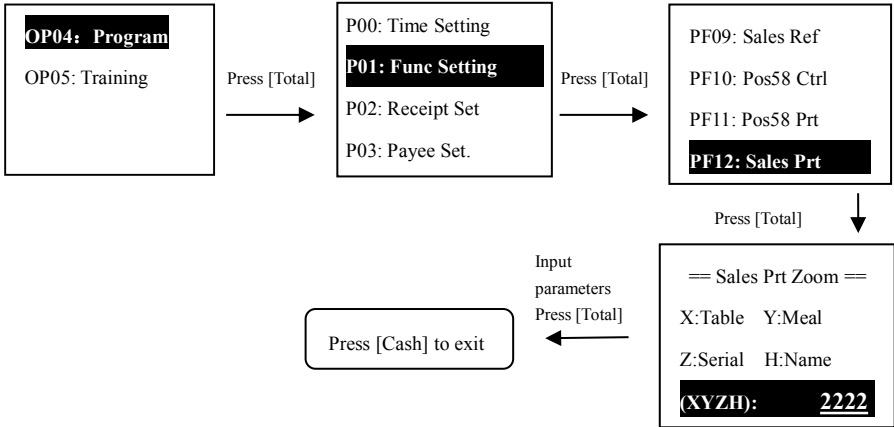

### 2. Settlement font size in the receipt (Note: settlement font size refers to the article 3 in Appendix A for setting)

Use steps: Press [Cash] and then press [X/Times↑] or [Change Price↓] for selecting an item, and press [Total]

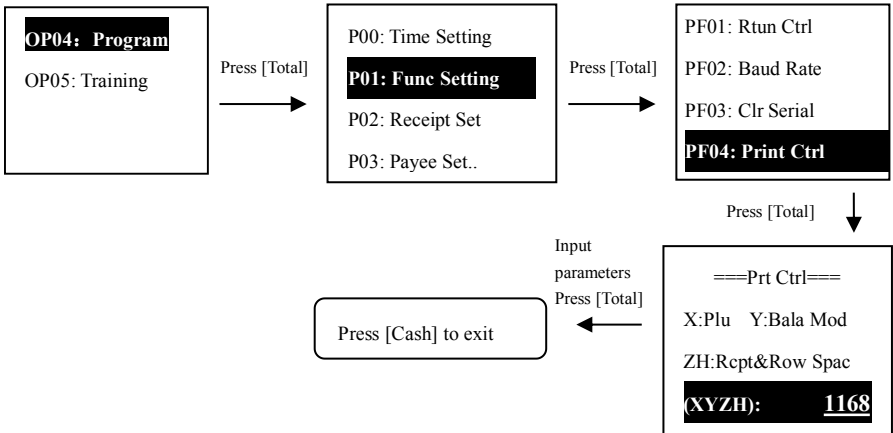

### 3. Repeat print bill

Repeat print bill manually: Directly press [Print] in the sales file for duplicating the previous bill.

Repeat print bill automatically: If need the cash register automatically connect for the printing bill, conduct the programming of parameters, and refer to the article 8 of Appendix A for programming. Only two pieces

can be printed successively.

Use steps: Press [Cash] and then press [X/Times↑] or [Change Price↓] for selecting an item, and press [Total]

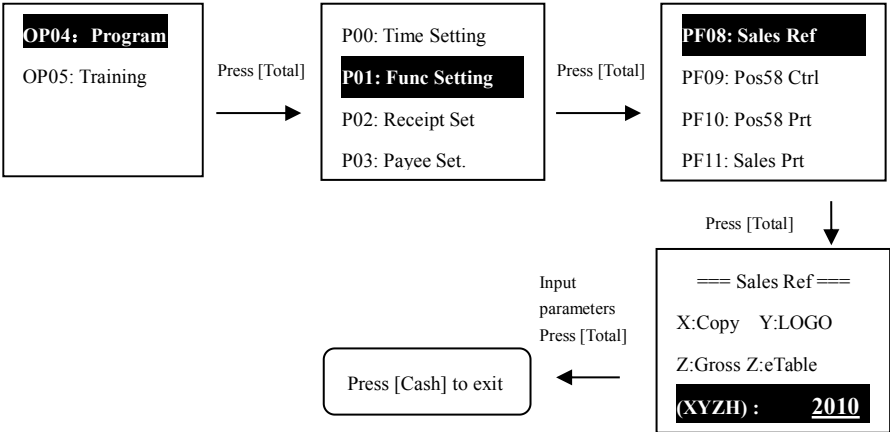

#### 4. Open the cash box

Open the cash box manually: Press [shift] + [Exchange] for opening the cash box and make records in the report.

Open the cash box of POS: If need to open the cash box of POS, first conduct the setting of a parameter function, and refer to the article 9 in Appendix A for programming.

Use steps: Press [Cash] and then press [X/Times↑] or [Change Price↓] for selecting an item, and press [Total]

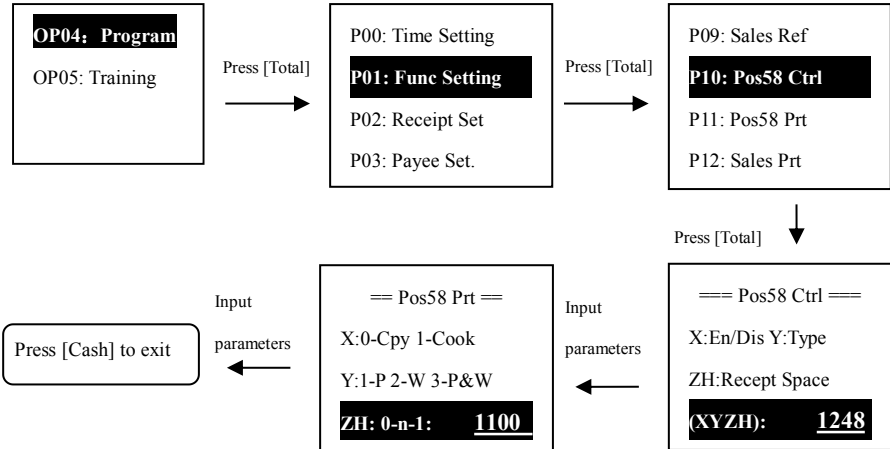

#### 5. Cash withdrawal and deposit due to abnormal sales

Use steps: Press [Cash] and then press [X/Times↑] or [Change Price↓] for selecting an item, and press [Total]

### Withdrawal operation:

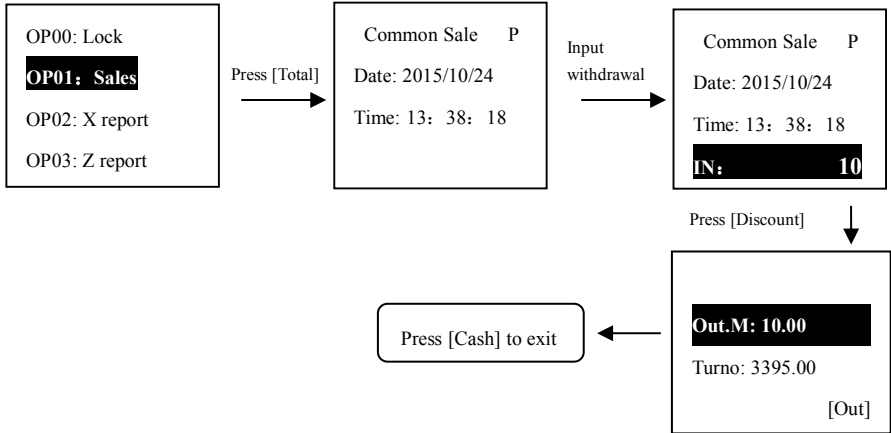

### Deposit operation:

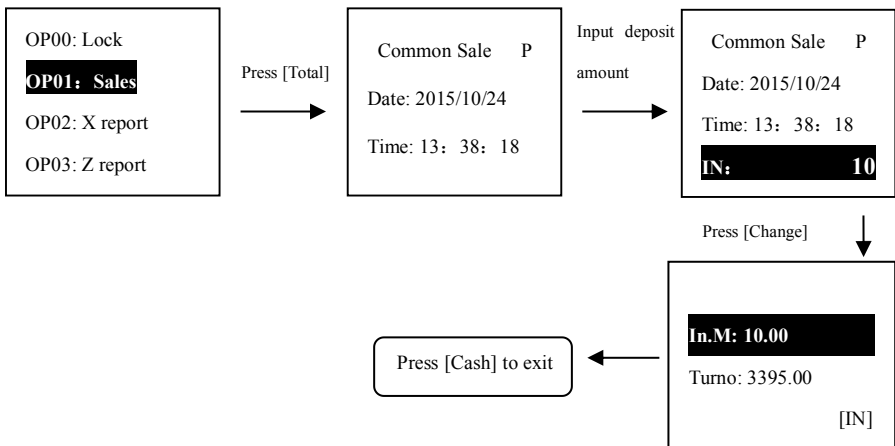

### 6. Ban/allow built-in printing

Use steps: Press [Cash] and then press [X/Times↑] or [Change Price↓] for selecting an item, and press [Total]

**Ban** built-in printing: [Shift] + [Print], [P] of sales interface disappears, then ban built-in printing.

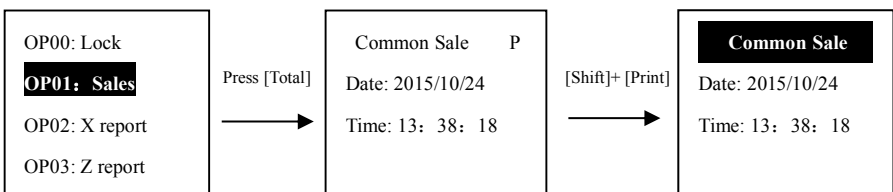

**Allow** built-in printing: [Shift] + [Print], [P] of sales interface appears, then allow built-in printing.

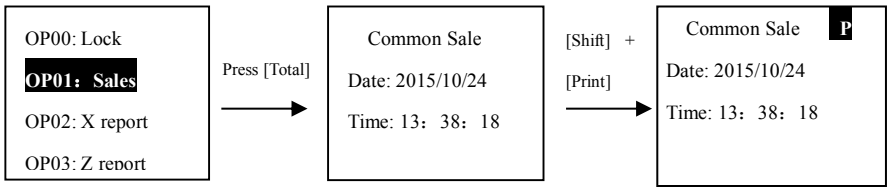

## 7. Bill printing speed

Use steps: Press [Cash] and then press [X/Times↑] or [Change Price↓] for selecting an item, and press [Total]

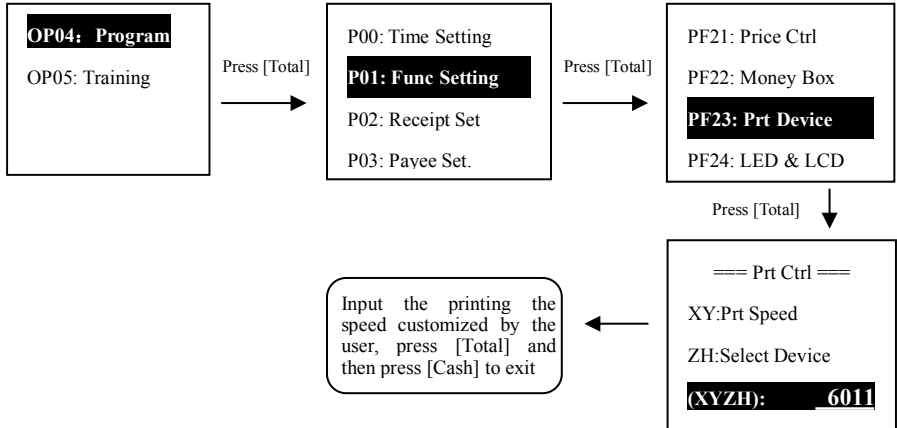

## 8. Error correction

Use steps: Press [Cash] and then press [X/Times↑] or [Change Price↓] for selecting an item, and press [Total]

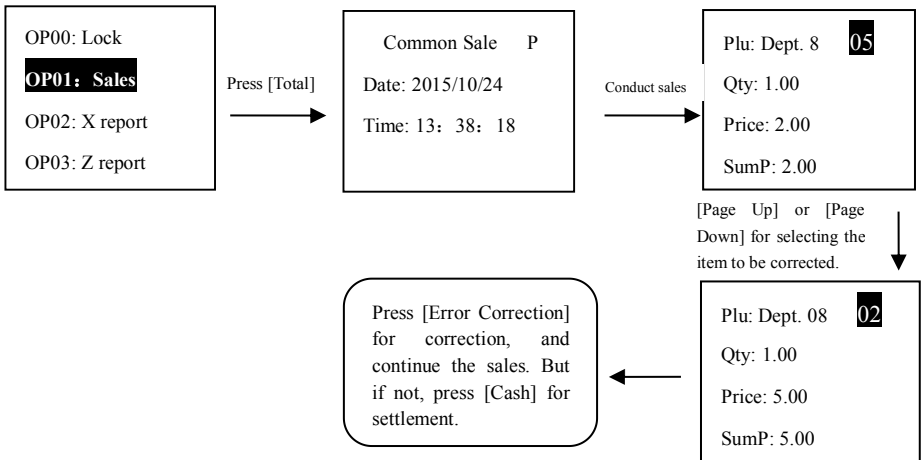

**(Note: only allow single-item correction. If need correction, repeat the operation)**

## 9. Cancel

Use steps: Press [Cash] and then press [X/Times↑] or [Change Price↓] for selecting an item, and press [Total]

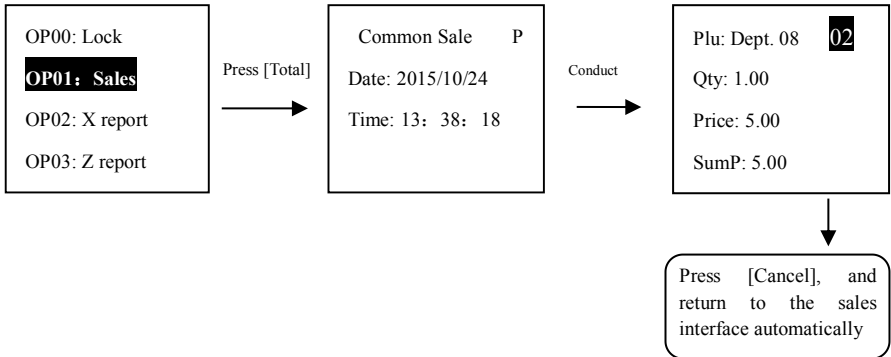

## 10. System information

Use steps: Press [Cash] and then press [X/Times↑] or [Change Price↓] for selecting an item, and press [Total]

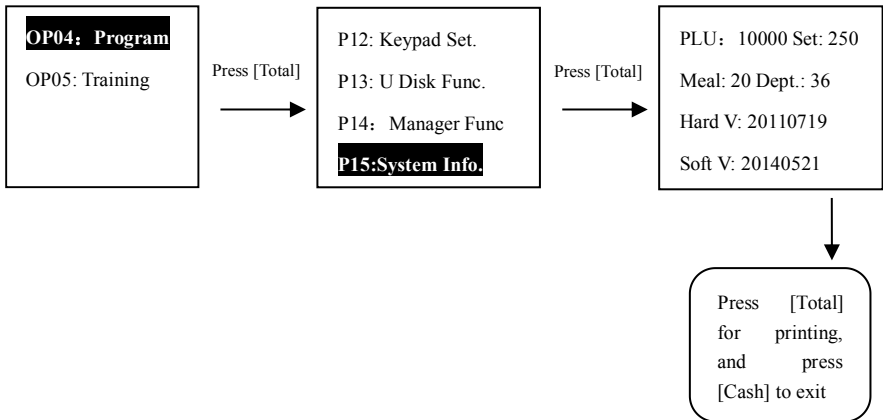

# Chapter 11 Various Statements

## 1. Financial statement

Financial statement means the records of specific sales within the sales period of the cash register.

The content of financial statement can be divided into three categories: Non-commodity sales (discount, mantissa removal), sales settlement category (cash, foreign exchange) and overall sales (gross revenue, gross profit).

**Note: Calculation formula of financial statement:**

**Gross revenue = business volume + discount + privilege - service charge - additional charge - mantissa removal**

**Gross profit = DPLU gross profit + PLU gross profit**

**DPLU gross profit = DPLU sales amount - DPLU sales volume × DPLU purchasing price**

**PLU gross profit = PLU sales amount - PLU sales volume × PLU purchasing price**

Use steps: Press [Cash] and then press [X/Times↑] or [Change Price↓] for selecting an item, and press [Total]

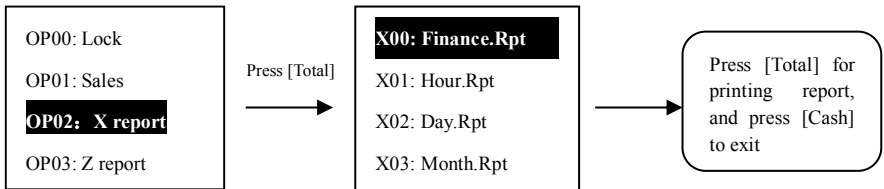

**The use step of using Z report is same with that of X report, but the difference is that Z report will remove the data when printing the report.**

## 2. Hourly report

Hourly report means the records of sales of the cash register every hour. (Note: 24 hours a day)

Use steps: Press [Cash] and then press [X/Times↑] or [Change Price↓] for selecting an item, and press [Total]

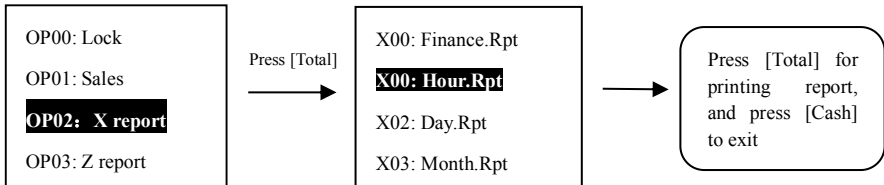

**The use step of using Z report is same with that of X report, but the difference is that Z report will remove the data when printing the report.**

## 3. Daily detail report

The daily detail report means the accumulation of all sales records on the current day by category. The report records of 1-31 days before the current day can be checked.

Use steps: Press [Cash] and then press [X/Times↑] or [Change Price↓] for selecting an item, and press [Total]

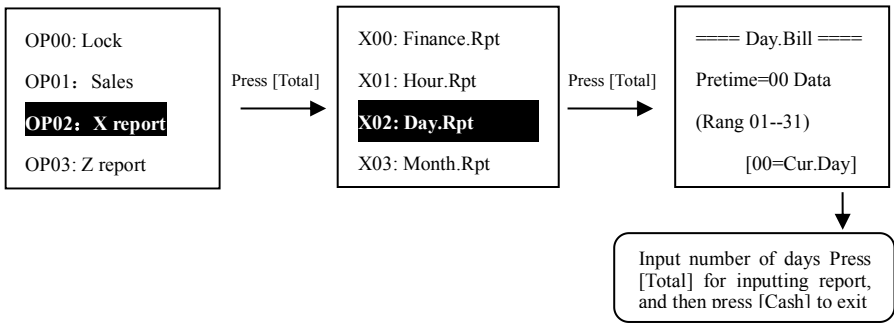

**The use step of using Z report is same with that of X report, but the difference is that Z report will remove the data when printing the report.**

#### 4. Monthly detail report

Monthly detail report means the accumulation of all sales records of the current month by category. The statement of 01-03 months before the current month can be printed.

Use steps: Press [Cash] and then press [X/Times↑] or [Change Price↓] for selecting an item, and press [Total]

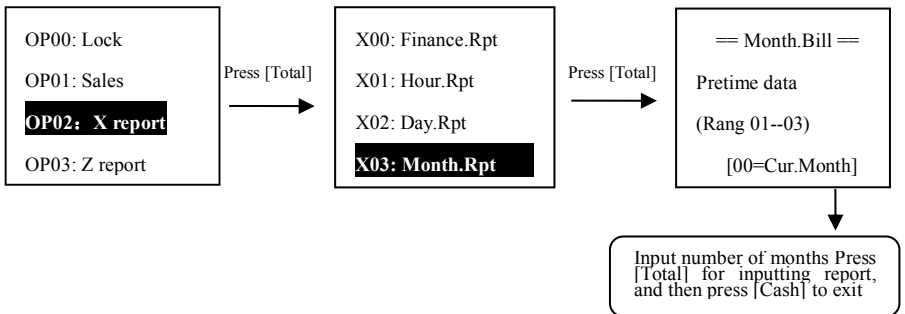

**The use step of using Z report is same with that of X report, but the difference is that Z report will remove the data when printing the report.**

#### 5. Receipt report

Receipt report means the records of sales of every cashier within the sales period.

Use steps: Press [Cash] and then press [X/Times↑] or [Change Price↓] for selecting an item, and press [Total]

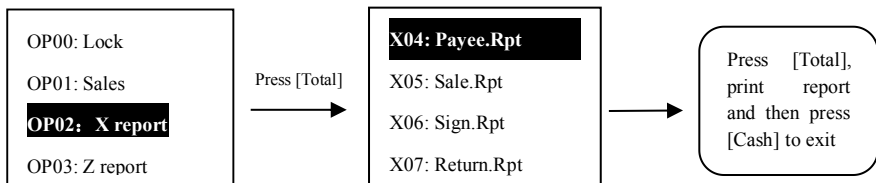

**The use step of using Z report is same with that of X report, but the difference is that Z report will remove the data when printing the report.**

## 6. Operating statement

Operating statement means the records of sales of every shop assistant within the sales period.

Use steps: Press [Cash] and then press [X/Times↑] or [Change Price↓] for selecting an item, and press [Total]

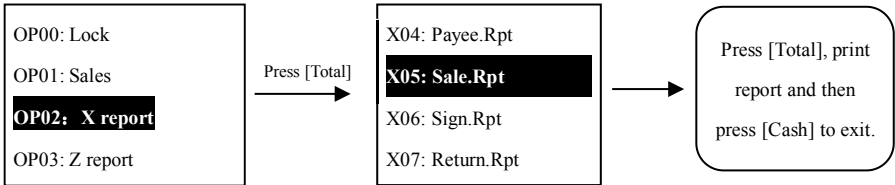

**The use step of using Z report is same with that of X report, but the difference is that Z report will remove the data when printing the report.**

## 7. Signing report

Customer signed the bill means the records of sales of every bill signing customer.

Use steps: Press [Cash] and then press [X/Times↑] or [Change Price↓] for selecting an item, and press [Total]

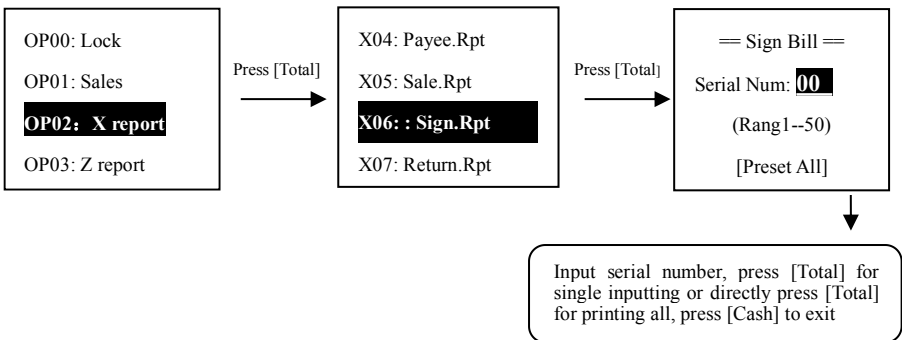

**The use step of using Z report is same with that of X report, but the difference is that Z report will remove the data when printing the report.**

## 8. Return report

The sales return report means the records of returns of commodity sold of the cash register.

Use steps: Press [Cash] and then press [X/Times↑] or [Change Price↓] for selecting an item, and press [Total]

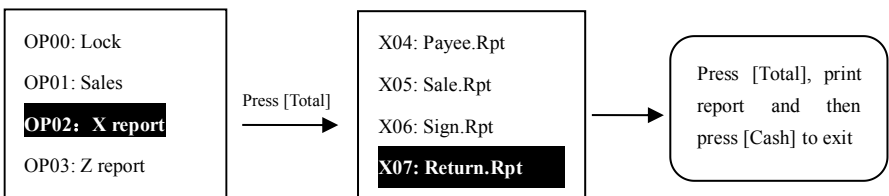

The use step of using Z report is same with that of X report, but the difference is that Z report will remove the data when printing the report.

### 9. Commodity (PLU) report

PLU report means the records of specific sales of all PLU of the cash register.

Use steps: Press [Cash] and then press [X/Times↑] or [Change Price↓] for selecting an item, and press [Total]

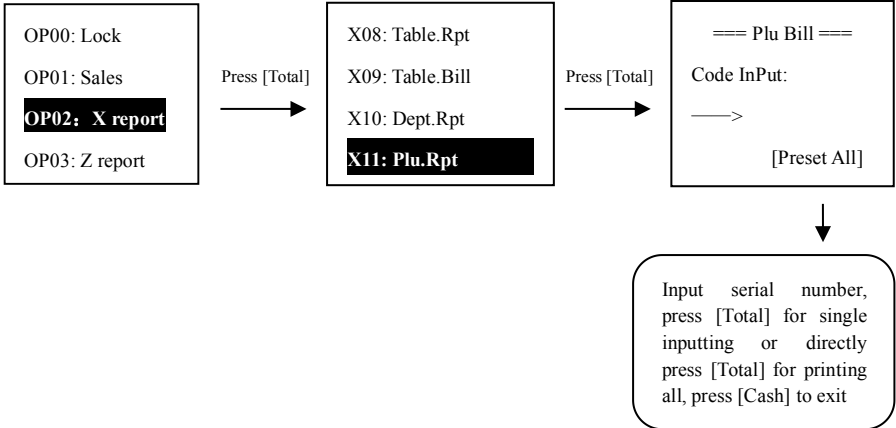

The use step of using Z report is same with that of X report, but the difference is that Z report will remove the data when printing the report.

### 10. Category (DEPT) report

The category report means the records of specific sales of all categories of the cash register.

Use steps: Press [Cash] and then press [X/Times↑] or [Change Price↓] for selecting an item, and press [Total]

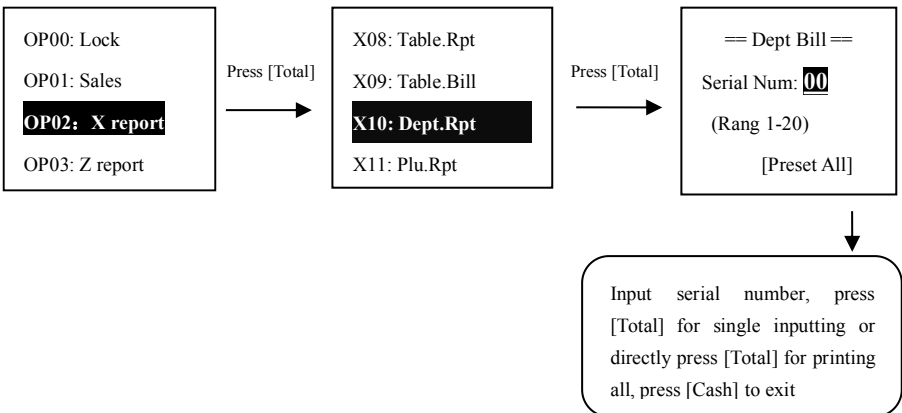

The use step of using Z report is same with that of X report, but the difference is that Z report will remove the data when printing the report.

### 11. Direct commodity (DPLU) report

DPLU report means the records of specific sales of all DPLU of the cash register.

Use steps: Press [Cash] and then press [X/Times↑] or [Change Price↓] for selecting an item, and press [Total]

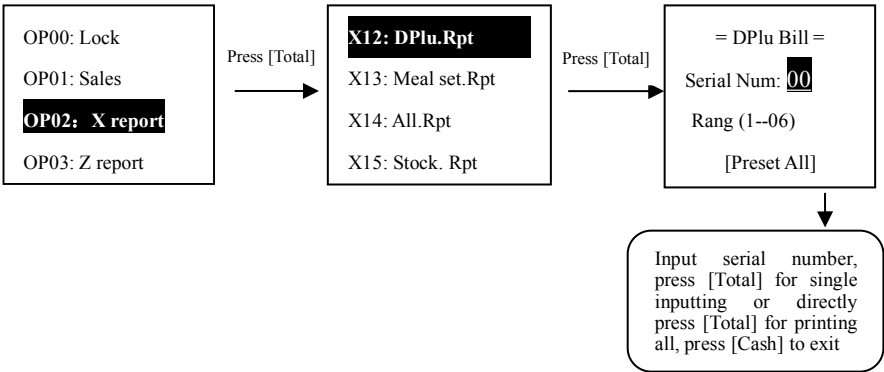

The use step of using Z report is same with that of X report, but the difference is that Z report will remove the data when printing the report.

### 12. Table report

The checkout counter report means the records of the sales of all checkout counters of the cash register (checkout counter sales have been settled).

Use steps: Press [Cash] and then press [X/Times↑] or [Change Price↓] for selecting an item, and press [Total]

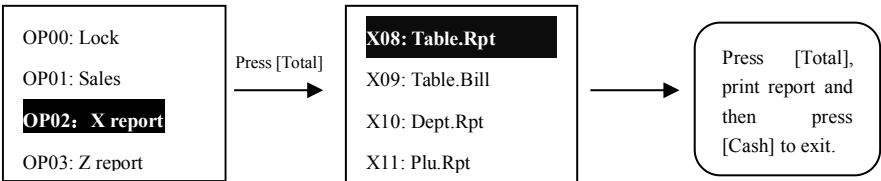

The use step of using Z report is same with that of X report, but the difference is that Z report will remove the data when printing the report.

### 13. Table Bill (Note: checkout counter list is only used to check the settlement suspension data stored in the memory.)

The checkout counter list means the records of the sale detail report of all checkout counters of the cash register (checkout counter sales have not been settled).

Use steps: Press [Cash] and then press [X/Times↑] or [Change Price↓] for selecting an item, and press [Total]

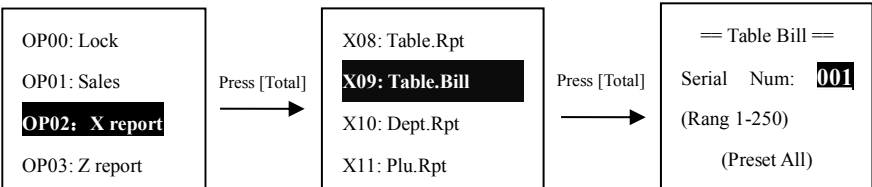

(Continue the unfinished content of last page ) ↓

Input the serial number for single-item printing, and directly press [Total] for printing all. Press [Cash] to exit

**The step of using Z report is same with that of X report. When printing the Z report, the report data will not be removed.**

#### 14. Meal set report

Package report means the records of the sales package.

Use steps: Press [Cash] and then press [X/Times↑] or [Change Price↓] for selecting an item, and press [Total]

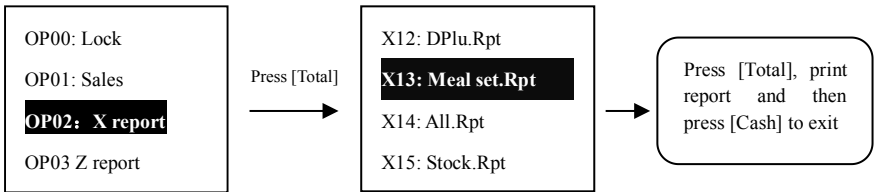

**The step of using Z report is same with that of X report. When printing the Z report, the report data will not be removed.**

#### 15. All report

Report summary means printing all reports in the cash register.

Use steps: Press [Cash] and then press [Multiple/Page Up] or [Price Input/Page Down] for selecting an item, and press [Total]

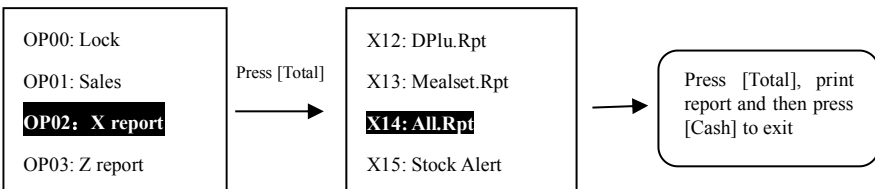

**The use step of using Z report is same with that of X report, but the difference is that Z report will remove the data when printing the report.**

## 16. Clr All Report

Report empty means that delete all report records in the cash register.

Use steps: Press [Cash] and then press [X/Times↑] or [Change Price↓] for selecting an item, and press [Total]

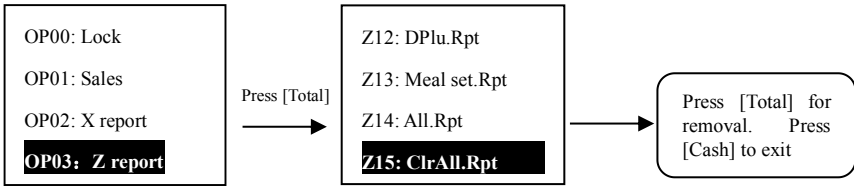

**Warning: After such operation, content of all reports will not be printed but removed. Please be careful to use them!**

## 17. Inventory alarm

Inventory alarm means the record report about the commodity (PLU) inventory shortage.

Use steps: Press [Cash] and then press [X/Times↑] or [Change Price↓] for selecting an item, and press [Total]

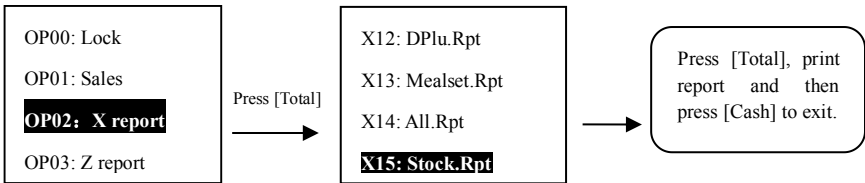

**The use step of using Z report is same with that of X report, but the difference is that Z report will remove the data when printing the report.**

## 18. PLU daily report

The PLU daily detail report means the records of commodity PLU sold on the current day and direct commodity.

Use steps: Press [Cash] and then press [X/Times↑] or [Change Price↓] for selecting an item, and press [Total]

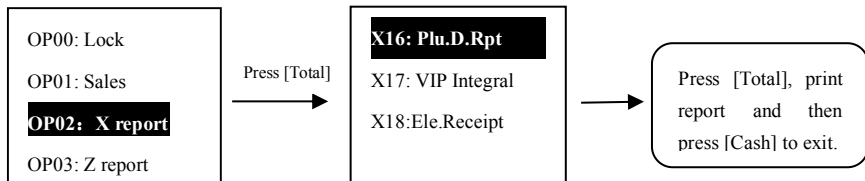

**The use step of using Z report is same with that of X report, but the difference is that Z report will remove the data when printing the report.**

## 19. VIP Integral

Member points mean the point brought during the consumption of consumers.

Use steps: Press [Cash] and then press [X/Times↑] or [Change Price↓] for selecting an item, and press [Total]

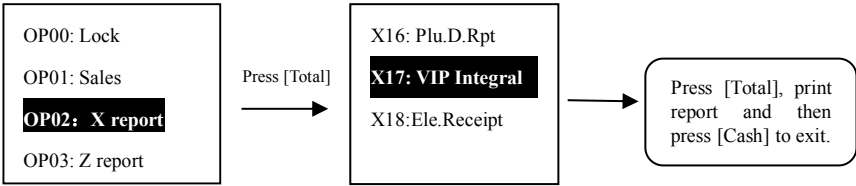

**The step of using Z report is same with that of X report. When printing the Z report, the report data will not be removed.**

## 20. Clear serial number

Clear away serial number means removing the serial number of the bill.

Use steps: Press [Cash] and then press [X/Times↑] or [Change Price↓] for selecting an item, and press [Total]

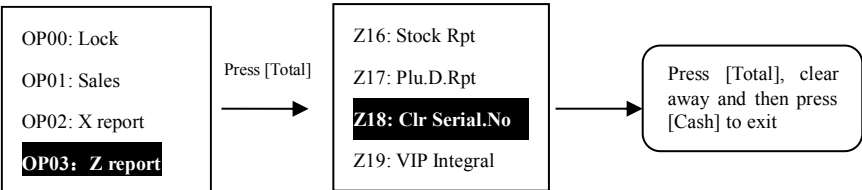

## Appendix A: System Function Parameter Definition List

Name of function number	Function value	Function annotation	Default	
00 Return control	XYZH	XY: =00, without password control =55, with password control Z: =1, print RMB in the receipt =0, print cash in the receipt	0000	
01 Separate window print	XYZH	X: =0, ban separate window printing =1, allow separate window printing Y: =0, normal printing of commodity name =1, double width printing of commodity name =2, double height printing of commodity name =3, magnification printing of commodity name Z: Print line clearance (point row)	0000	
02 Clear serial number		X: =0, ban removing sales serial number (print Z report) =1, allow removing sales serial number (print Z report) YZH: Automatic reset value of serial number is customized by the user.	1000	
03 Print Control	XYZH	X: =0, ban printing PLU or code =1, allow printing PLU or code Y: =0, normal printing of settlement =1, double width printing of settlement =2, double height printing of settlement =3, magnification printing of settlement Z: Receipt clearance (character row) H: Print line clearance (point row)	1168	
04 Add Rate	XYZH	Service ratio	Factory default value 1%	0100
05 Discount Rate	XYZH	Discount ratio	Factory default value 1%	0100
06 Sale Crz	XYZH	X: =0, ban removing mantissa automatically =1, allow removing mantissa automatically Y: =0, ban printing with removing mantissa =1, allow printing with removing mantissa Z: =1, remove mantissa =2, round off mantissa =3, round off mantissa H: =1, remove mantissa by jiao =2, remove mantissa by fen	1022	

<p>07 Report Control</p>	<p>XYZH</p>	<p>X: =4, allow printing financial statement  =2, allow printing hourly report  =1, allow printing the detail report of the current day  Y: =4, allow printing signing report  =2, allow printing the detail report of the current month  =1, allow printing report  Z: =4, allow printing cashier's report  =2, allow printing shop assistant's report  =1, allow printing checkout counter statement and checkout counter list statement  H: =4, allow printing category report  =2, allow printing DPLU report  =1, allow printing PLU report  For example: Report summary needs to print financial statement, and hourly report and cashier report  Set up X=6 (4+2) Y: =0 Z: =4 H: =0, such parameter is "6040"</p>	<p>7777</p>
<p>08 Print setting</p>	<p>XYZH</p>	<p>X: Duplicate the receipt =2, Duplicate two receipts and print them.  Y: Print LOGO Z: Gross revenue and gross profit printing  H: Printing of external POS number (0 Ban, 1 Allow)</p>	<p>1101</p>
<p>09 POS58 Prt</p>	<p>XYZH</p>	<p>X: =0, ban serial port printer  =1, allow 32-character/serial printer  =3, allow 42-character/serial printer  Y: =0, general purpose printer (such as LQ-300K)  =1, POS-58 paper-cutting printer  =2, POS start cashbox  =3, TM-290/295 flat-bed printer  =4, SBP-290II flat-bed printer  Z: Number of null row of external print receipt head  H: Row clearance of external print receipt (flat-bed)  Number of null line of external print receipt rear (others)  XY: =10, support external connection with POS  XY: =11, support external connection with POS paper-cutting  XY: =12, external connection with POS cash box  XY: =13, support external connection with POS paper-cutting cash box  XY: =14, support external connection with POS and magnification of commodity name</p>	<p>0024</p>

10 POS 58 Ctr	XYZH	X: =0, fully replicate and print X: =1, kitchen print Y: =0, do not print by single window Y: =1, separate bill printing Y: =2, print by separate window Y: =3, print by separate bill and window Z H: =06, meaning the external connection with communication port, window print category (01- 06) External connection of barcode port, window print category (07-36)	1000
11 Sales print	XYZH	X: =0, normal printing of checkout counter number X: =1, double width printing of checkout counter number =2, double height printing of checkout counter number =3, the full magnification of the checkout counter number Y: =0, normal printing of package No. Y: =1, double width printing of checkout package No. =2, double height printing of package No. =3, magnification printing of package No. Z: =0, normal printing of checkout serial number, Z: =1, double width printing of checkout serial number =2, double height printing of serial number =3, magnification printing of the serial number H: =0, normal printing of commodity name, H: =1, double width printing of commodity name =2, double height printing of commodity name =3, magnification printing of commodity name	0000
12 Meal Ctrl	00ZH	Z: =0, ban printing package content =1, allow printing package content H: =0, no influence upon commodity inventory =1, influence upon commodity inventory	0000
13 Prog Rst	XY00	X: =0, ban PLU inventory mantissa removal =1, allow PLU inventory mantissa removal Y: =0, ban removing PLU =1, allow removing PLU	0100
14 Stock Alert	XYZH	User-defined. When the inventory is less than the number set by the user, X/Z inventory alarm statement will be printed.	0100
15 E-scal 01	XYZH	X: =0, ban barcode scale sales =1, barcode scale sales in unit of weight =2, barcode scale sales in unit of amount =4, connect electronic barcode scale for sales Y: Digits of commodity code, 1~3 shall not be less than 1 digit and more than 13 digits. Z: For commodity measuring digit, the factory default value is 4-digit number and two decimal places	0462

16 E-scal 02	XYZH	XY: Barcode digits <=13 digits ZH: Lead code number of barcode scale is <=2 digits		1322
17 Cmsn Ctrl	XY00	X: Cashier      Y: Shop assistant 1: Business volume      2: Gross margin X: =1, mean that the cashier commission is calculated with business volume. X: =2, mean that the cashier commission is calculated with gross margin. Y: =1, mean that the shop assistant commission is calculated with business volume. Y: =2, mean that the shop assistant commission is calculated with gross margin.		0000
18 Payee Rate	XYZH	Cashier commission ratio	Factory default value 0%	0000
19 Sales Rate	XYZH	Shop assistant commission ratio	Factory default value 0%	0000
20 Price Ctrl	XYZH	X: =0, ban the small change sales when sell =1, allow the small change sales when sell Y: =0, ban the sale at variable price when sell =1, allow sale at variable price sales when sell ZH: =00		1100
21 Money Box	XYZH	X: Starting of withdrawal and deposit cash box (0 Ban, 1 Allow) Y/Z: Starting of the small change cash box		1010
22 Print Ctrl	XYZH	XY: Bill printing speed (user-defined bill printing speed) ZH: Selection of printing equipment		6011
23 LED and LCD	XYZH	Such an item has been set up when leaving the factory, and can be defined by the user.		0550
24 Unified taxes	XYZH	X: =0, ban unified adding-taxes =1, allow unified adding-taxes YZH: Tax rate (a user adds taxes rate according to the needs)		0000
25 VIP setting	XYZH	X: =1, when member price is 0, sell with purchasing price. YZH: =000		0000

## Appendix B: Keyboard custom key value comparison table

**Keyboard seat number table**

<b>1</b>	<b>2</b>	<b>3</b>	<b>4</b>	<b>5</b>	<b>6</b>	<b>7</b>	<b>8</b>
<b>9</b>	<b>10</b>	<b>11</b>	<b>12</b>	<b>13</b>	<b>14</b>	<b>15</b>	<b>16</b>
<b>17</b>	<b>18</b>	<b>19</b>	<b>20</b>	<b>21</b>	<b>22</b>	<b>23</b>	<b>24</b>
<b>25</b>	<b>26</b>	<b>27</b>	<b>28</b>	<b>29</b>	<b>30</b>	<b>31</b>	<b>32</b>
<b>33</b>	<b>34</b>	<b>35</b>	<b>36</b>	<b>37</b>	<b>38</b>	<b>39</b>	<b>40</b>

**Custom key value comparison table**

00-number 0	13-cash	26-shift	39-DPLU4	52-department11
01-number 1	14-foreign exchange1/5	27-cancel/sales return	40-DPLU5	53-department12
02-number 2	15-foreign exchange2/6	28-error correction /remove mantissa	41-DPLU6	54-department13
03-number 3	16-foreign exchange 3/7	29-clear away	42- department 1	55-department14
04-number 4	17-foreign exchange4/8	30-cashier/shop assistant	43-department2	56-department15
05-number 5	18-Credit card	31-checkout counter/ settlement suspension	44- department3	57-department16
06-number 6	19 -signing	32 - multiply	45- department4	58-department17
07-number 7	20-service charge	33-input PLU	46- department5	59-department18
08-number 8	21-discount/coupon	34-PLU	47- department6	60-department19
09-number 9	22-discount	35-package	48- department7	61-department20
10-decimal point	23- feed	36-DPLU1	49- department8	62-member
11-number00	24-print	37-DPLU2	50- department9	63-electronic scale
12-Total	25-backspace	38-DPLU3	51- department10	

## **Appendix C: Common problem-solving methods of cash register**

**Following contents are only used for fault removal of several machines, because all models are not same. If you have any questions, please contact the supplier or manufacturer.**

### **Printing paper shortage?**

Solution: Prompt that printing paper has been used up. Please change.

### **Printing head is overheating?**

Solution: Uncover for checking whether the print head has paper jam.

### **Is keyboard messy?**

Solution: Directly press the power switch for turning the power supply, keep pressing [Subtotal] for start-up, and press [Subtotal] after displaying the prompt.

### **Is unfinished sales?**

Solution: Press [Cash], [Multiply/Page Up] and [PLU price change/Page Down] and return to the sales office, and continue to complete the sales.

### **Is constant printing after starting?**

Solution: Press [Cash] for selecting programming, turn off the power supply, and keep pressing [Cash] for the start-up.

### **Fail to start checkout counter?**

Solution: Press [Cash] for selecting training, and press [Subtotal] for conducting keyboard test, whether [Checkout Counter] can't be used.

### **Fail to change price and conduct small change sales?**

Solution: Press [Cash] for selecting programming, press [Subtotal] for entering "functional programming" to "selling price control", press [Subtotal] for setting up [1100], and refer to Appendix A for programming.

### **How to add company name or LOGO to the receipt?**

Solution: Press [Cash] for selecting programming, press [Subtotal] for entering "receipt programming", and press [Subtotal] for entering the first row programming (refer to the Page 6 in this manual for programming). Special sign shall be made in the computer.

### **How to print package content of the package sales receipt?**

Solution: Press [Cash] for selecting programming, press [Subtotal] for entering "functional programming" to "package setting", and set to be [0010], and refer to Appendix A for programming.

### **How to set up the magnification of serial number and commodity number?**

Solution: Press [Cash] for selecting programming, press [Subtotal] for entering "functional programming" to "sales print", and set to be [0010], and refer to Appendix A for programming.

### **How to cancel one item during the sales?**

Solution: Select the item to be canceled during the sales, and press [Error Correction] for canceling the sales.

### **Printing of POS?**

Solution: Press [Cash] for selecting programming, press [Subtotal] for entering "functional programming" to "serial printing" and set to be [1168], and then press [Subtotal] for entering " POS control" and set to be [1100], and refer to Appendix A for programming. If connecting the computer, need to install the drive.

### **How to set up automatic paper-cutting POS?**

Solution: Press [Cash] for selecting programming, press [Subtotal] for entering "functional programming" to "serial printing", and set to be [1248]  
Then press [Subtotal] for entering "POS control", set to be [1100], and also can refer to Appendix A for programming.

### **How to open cash box manually?**

Solution: Press [Cash] for selecting sales, and directly press [shift] + [foreign exchange] after pressing [Subtotal], and then open the cash box.

### **How to conduct separate bill and separate window printing?**

Solution: Press [Cash] for selecting programming, press [Subtotal] for entering "functional programming" to "serial printing" and set to be [1168], and then press [Subtotal] for entering " POS control" and set to be [1305], and refer to Appendix A for programming.

### **Fail to recognize the letter of barcode?**

Solution: Barcode gun fails to recognize the barcode containing letter, and barcode is not clear or barcode gun is damaged.

### **Fail to return commodity?**

Solution: Press [Cash] for selecting Z sport, and press [Subtotal] for selecting returns report for removal, and then continue the returns of commodity.

### **How to do in case of time stop?**

Solution: Restore the factory setting of the cash register or connect the computer and open the software to sync time.

### **For wrong connection with upper computer, prompt error 1 or 2?**

Solution: Error 1: It means that the computer serial port is occupied or this serial port doesn't exist. Check whether the system connection is correct.

Error 2: It means that the serial port has a problem or the cash register has no response after transmitting data.

### **How to unlock?**

Solution: Cash register has been locked, press [Cash] and input the serial number and password, and then press [Subtotal] for confirmation.

### **Fail to connect USB with computer?**

Solution: Check whether the pot is inserted and data line is sound.

### **Printing paper can't print receipt during the sales, what's the matter?**

Solution: Check whether there is [P] in sales interface and the top right corner of main screen. If not, press [Shift] + [Print], but if still not, restore the factory setting.

### **How to clear away serial number?**

Solution: Press [Cash] for selecting programming, press [Subtotal] for entering "functional programming" to "serial number removal", set to be [1000], and remove serial number in "Z report".

**Main screen become green or there is no display?**

Solution: Check whether the keyboard and second screen have response, or check main board for test, and remove the upper cover of the machine for inserting and plugging the main screen line. If there is still problem, the main board has been damaged, and please send to the after-sales maintenance station.

**Data about PLU commodity is record the day before yesterday, but the data disappeared today?**

Solution: Check whether the battery is sound, and connect the cash register with power supply for charging at least 8 hours.

**Printer can deliver paper but can't print?**

Solution: Printing paper may be placed inversely. After placing the paper, print the test paper manually.

**Green status lamp of the printer flickers?**

Solution: For paper shortage of printer, place the printing paper well.

**After connecting the scanning gun with cash register, there is sound but barcode fails to be scanned.**

Solution: Reset up the communication port of the barcode gun, protocol 9600N81 N81: Without 8 check bits, 1 stop bit; Reset up the communication Baud rate of the cash register to be 9600.

**How to shorten the bill clearance of the cash register?**

Solution: Press [Cash] for selecting programming and entering "functional programming" to "printing parameter", and set to be [1128] or [1138].

**How to shorten the bill clearance of the printer?**

Solution: Press [Cash] for selecting programming, press [Subtotal] for entering "functional programming" to "serial printing and set to be [1128], [1024] and [1012].

**How to change the inventory of commodity PLU and remove commodity PLU?**

Solution: Press [Cash] for selecting programming, press [Subtotal] for entering "functional programming" to "mantissa removal programming", and set to be [1100]

**How to operate the unified adding-taxes?**

Solution: Press [Cash] for selecting programming, press [Subtotal] for entering "functional programming" to "unified adding-taxes", and set to be [1yz.h], with yz.h% of tax rate (user-defined).

**How to conduct the member setting?**

Solution: Press [Cash] for selecting programming, press [Subtotal] for entering "functional programming" to "member setting", and set to be: For member price, when setting to be [1000], member price adopts selling price for sales; When setting to be [0000], member price adopts 0 for sales.

**How to use cashier 02 and shop assistant 05 to log in system?**

Solution: Under the locked state, first input cashier number 02 then input its password, press "subtotal" for unlocking, input shop assistant number 05 and press "cashier and shop assistant" keys.

## Appendix D: Receipt sample

```

*****
Commodity PLU sales receipt
*****
Time: 2015/10/30 09: 13 001#0002
Payee: Payee01 Sale: Saler 01
Item      Qty      Price     Total
-----
Apple     1.00     8.00     8.00
Grape     1.00    15.00    15.00
-----
Total Qty:                2.00
Total Amount:             23.00
Cash:                    23.00
*****
Welcome to come again
Thank you for shopping with us
    
```

```

*****
Dept sales receipt
*****
Time: 2015/10/30 09: 14 001#0003
Payee: Payee01 Sale: Saler 01
Item      Qty      Price     Total
-----
Orange    1.00    10.00    10.00
Watermelon 1.00     5.00     5.00
-----
Total Qty:                2.00
Total Amount:             15.00
Cash:                    15.00
*****
Welcome to come again
Thank you for shopping with us
    
```

```

*****
Direct commodity DPLU sales receipt
*****
Time: 2015/10/30 09: 20 001#0004
Payee: Payee01 Sale: Saler 01
Item      Qty      Price     Total
-----
Fruit     1.00    20.00    20.00
Vegetable 1.00    18.00    18.00
-----
Total Qty:                2.00
Total Amount:             38.00
Cash:                    38.00
*****
Welcome to come again
Thank you for shopping with us
    
```

```

*****
Package sales receipt
*****
Time: 2015/10/30 09: 25 001#0005
Payee: Payee01 Sale: Saler 01
Item      Qty      Price     Total
-----
Buffet    1.00    20.00    20.00
Family Meal 1.00    50.00    50.00
-----
Total Qty:                2.00
Total Amount:             70.00
Cash:                    70.00
*****
Welcome to come again
Thank you for shopping with us
    
```

\*\*\*\*\*

Checkout counter sales receipt

\*\*\*\*\*

Time: 2015/10/30 09: 30 001#0006

Payee: Payee01 Sale: Saler 01

Item	Qty	Price	Total
-----	-----	-----	-----

\*\*\*Counter number 001 checkout counter\*\*\*

Apple	1.00	8.00	8.00
-----	-----	-----	-----

Total Qty: 1.00

Total Amount: 8.00

Cash: 8.00

\*\*\*\*\*

Welcome to come again  
Thank you for shopping with us

\*\*\*\*\*

Sales receipt of settlement suspension of checkout counter

\*\*\*\*\*

Time: 2015/10/30 09: 35 001#0007

Payee: Payee01 Sale: Saler 01

Item	Qty	Price	Total
-----	-----	-----	-----

\*\*\*Counter number 001 checkout counter\*\*\*

Apple	1.00	8.00	8.00
-----	-----	-----	-----

Total Qty: 1.00

Total Amount: 8.00

Cash: 8.00

\*Counter number 001 settlement suspension\*

Welcome to come again  
Thank you for shopping with us

\*\*\*\*\*

Sales receipt of change of checkout counter

\*\*\*\*\*

Time: 2015/10/30 09: 40 001#0008

Payee: Payee01 Sale: Saler 01

Item	Qty	Price	Total
-----	-----	-----	-----

\*\*\*Opening of counter number 001\*\*\*

Apple	1.00	8.00	8.00
-----	-----	-----	-----

\*\*\*\*\*Change of counter 002\*\*\*\*\*

Grape	1.00	15.00	15.00
-----	-----	-----	-----

Total Qty: 2.00

Total Amount: 23.00

Cash: 23.00

\*\*\*\*\*

Welcome to come again  
Thank you for shopping with us

\*\*\*\*\*

Returns sales receipt

\*\*\*\*\*

Time: 2015/10/30 09: 45 001#0009

Payee: Payee01 Sale: Saler 01

Item	Qty	Price	Total
-----	-----	-----	-----

Apple	-1.00	8.00	-8.00
-----	-----	-----	-----

Grape	-1.00	15.00	-15.00
-----	-----	-----	-----

Total Qty: -2.00

Total Amount: -23.00

Cash: -23.00

\*\*\*\*\*

Welcome to come again  
Thank you for shopping with us

\*\*\*\*\*

**Single discount sales receipt**

\*\*\*\*\*

Time: 2015/10/30 09: 50 001#0010  
 Payee: Payee01 Sale: Saler 01

Item	Qty	Price	Total
Tangerine	1.00	10.00	10.00
Watermelon	1.00	5.00	5.00
Discount (item 02 10.00%)			-0.50
Total Qty:			2.00
Total Amount:			14.50
Cash:			14.50

\*\*\*\*\*

Welcome to come again  
Thank you for shopping with us

\*\*\*\*\*

**Overall discount sales receipt**

\*\*\*\*\*

Time: 2015/10/30 10: 18 001#0011  
 Payee: Payee01 Sale: Saler 01

Item	Qty	Price	Total
Tangerine	1.00	10.00	10.00
Watermelon	1.00	5.00	5.00
Discount (overall 10.00%)			-1.50
Total Qty:			2.00
Total Amount:			13.50
Cash:			13.50

\*\*\*\*\*

Welcome to come again  
Thank you for shopping with us

\*\*\*\*\*

**Single service charge sales receipt**

\*\*\*\*\*

Time: 2015/10/30 10: 20 001#0012  
 Payee: Payee01 Sale: Saler 01

Item	Qty	Price	Total
Buffet	1.00	20.00	20.00
Family Meals	1.00	50.00	50.00
Service charge (item 02 10.00%)			5.00
Total Qty:			2.00
Total Amount:			75.00
Cash:			75.00

\*\*\*\*\*

Welcome to come again  
Thank you for shopping with us

\*\*\*\*\*

**Overall service charge sales receipt**

\*\*\*\*\*

Time: 2015/10/30 10: 21 001#0013  
 Payee: Payee01 Sale: Saler 01

Item	Qty	Price	Total
Buffet	1.00	20.00	20.00
Family Meals	1.00	50.00	50.00
Service charge (overall 10.00%)			7.00
Total Qty:			2.00
Total Amount:			77.00
Cash:			77.00

\*\*\*\*\*

Welcome to come again  
Thank you for shopping with us

X/Z - direct commodity PLU report

\*\*\*\*\*

Time: 2015/10/30 10: 23 006#0006

Product name Quantity Amount

Gross profit Inventory

-----  
 Fruit 2.00 40.00  
 10.00 0.00  
 -----

Vegetable 1.00 18.00  
 6.00 0.00  
 -----

Direct DPLU commodity3 0.00 0.00  
 0.00 0.00  
 -----

Direct DPLU commodity4 0.00 0.00  
 0.00 0.00  
 -----

Direct DPLU commodity5 0.00 0.00  
 0.00 0.00  
 -----

Direct DPLU commodity6 0.00 0.00  
 0.00 0.00  
 -----

Total Amount: 58.00  
 -----

X/Z - category report

\*\*\*\*\*

Time: 2015/10/30 10: 30 004#0004

Product name Quantity Amount

Number of times of discount Discount amount

-----  
 Tangerine 10.00 131.00  
 0002T 2.00  
 Watermelon 5.00 20.00  
 0002T 1.00  
 -----

Total Amount: 148.00  
 -----

X/Z - commodity PLU report

\*\*\*\*\*

Time:2015/10/30 10: 35 005#0005

Code Commodity name

Quantity Amount Gross margin

-----  
 000000000123 Apple  
 1.00 8.00 4.00  
 -----

000000000124 Grapes  
 1.00 15.00 5.00  
 -----

Total Amount: 23.00  
 -----

X/Z - package report

\*\*\*\*\*

Time: 2015/10/30 11: 23 007#0007

Product name	Quantity	Amount
Number of times of discount		Discount amount

Buffet	3.00	60.00
--------	------	-------

Family Meals	3.00	150.00
--------------	------	--------

Total Amount:		210.00
---------------	--	--------

Member sales receipt

\*\*\*\*\*

Time: 2015/10/30 11: 35 001#0012

Cashier: Cashier 01 shop assistants: Shop assistant 01

Membership ID: 0000902538001

Item	Qty	Price	Total
Apple	1.00	6.00	6.00
Grape	1.00	12.00	12.00

Total number:		2.00
---------------	--	------

Amount in total:		18.00
------------------	--	-------

Cash:		18.00
-------	--	-------

Member point:		1
---------------	--	---

Accumulative points this time:		1
--------------------------------	--	---

\*\*\*\*\*

Welcome to come again

Thank you for shopping with us

X/Z - checkout counter report

\*\*\*\*\*

Time: 2015/10/30 11: 32 002#0002

Ratio	Number of times	Amount
Checkout Counter No. 001		
22.22%	0001T	10.00
Checkout Counter No. 003		
77.78%	0001T	35.00
Total Amount:		45.00

X/Z -all of the registered member's data

\*\*\*\*\*

No.: 0000902538001

Integral: 0

Name: Zhang San

Address: \*\*Province \*\*City \*\*County

\*\*Village \*\*Number

Tel: 01597562465

No.: 0000902538002

Integration: 0

Name: Li Si

Address: \*\*Province \*\*City \*\*County

\*\*Village \*\*Number

Tel: 01657462546

X/Z - returns report

\*\*\*\*\*

Time:2015/10/30 11: 40 001#0001

Product name Quantity Amount

-----

Returns time: 2015/10/3009: 17

Tangerine 1.00 10.00

-----

Returns time: 2015/10/30 09: 17

Watermelon 1.00 5.00

-----

Total number of times 0001

Total Amount: 15.00

-----

X/Z - checkout counter list report

\*\*\*\*\*

Time: 2015/10/30 11: 45 001#0001

Product name Quantity Amount

-----

Checkout Counter No. 001

Tangerine 1.00 10.00

-----

Amount in total: 10.00

-----

Checkout Counter No. 002

Watermelon 1.00 5.00

-----

Total Amount: 15.00

-----

**Normal power supply**

