

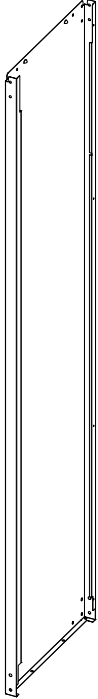

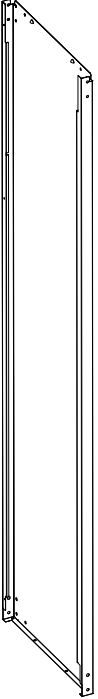

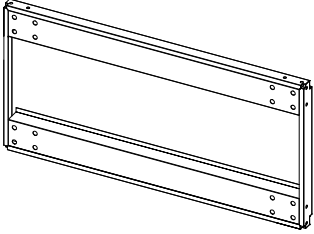

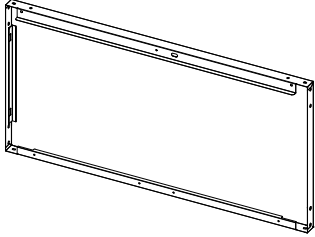

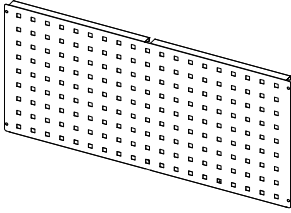
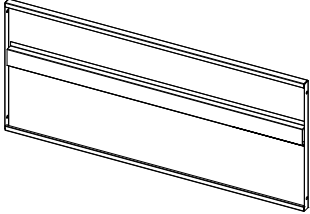
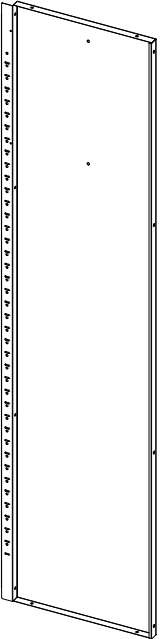
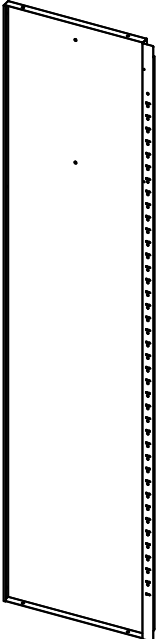
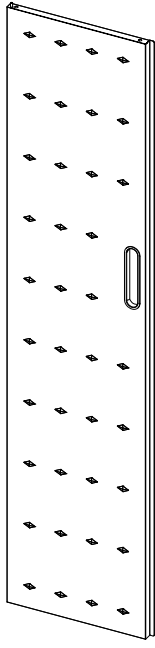
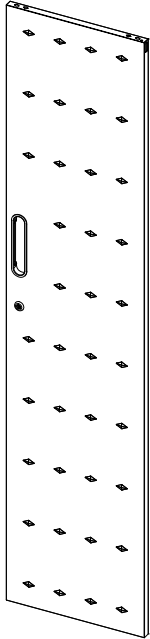



1×1pc 		2×1pc 		3×1pc 		4×1pc 	
				5×1pc 		6×3pcs 	
7×1pc 		8×1pc 		9×1pc 		10×1pc 	
A×24pcs  M4×8mm	B×16pcs  M8×20mm	E×52pcs  M5×10mm	F×12pcs 	G×36pcs  M5	Q×12pcs 	R×2pcs 	U×4pcs 
4pcs 	W×8pcs 						

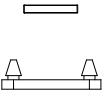

1

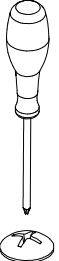

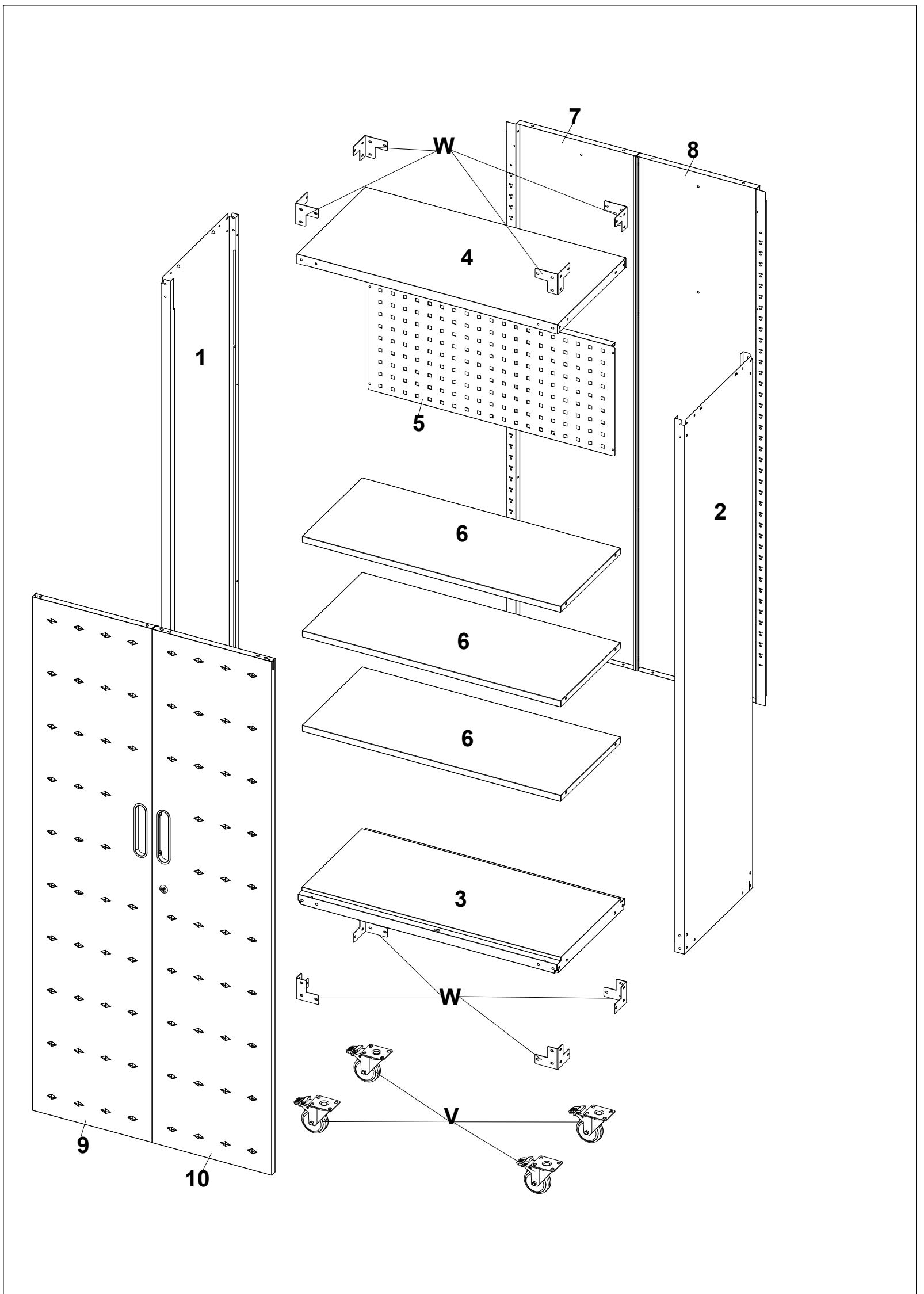
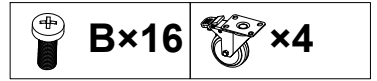
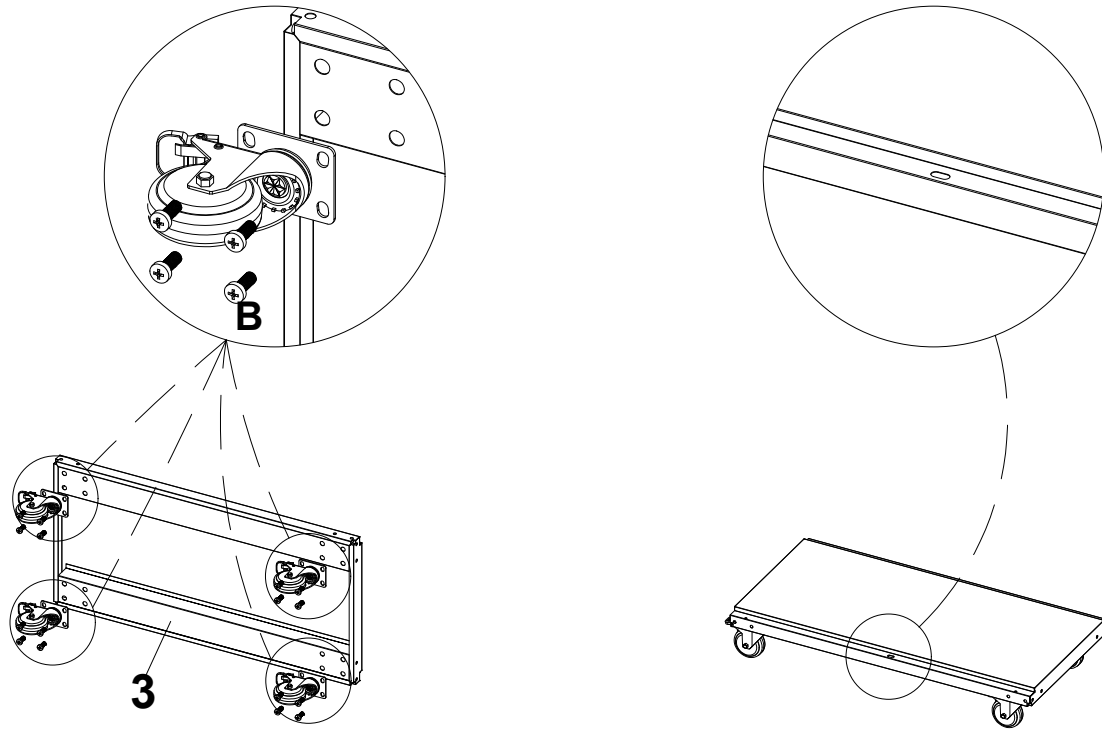
2

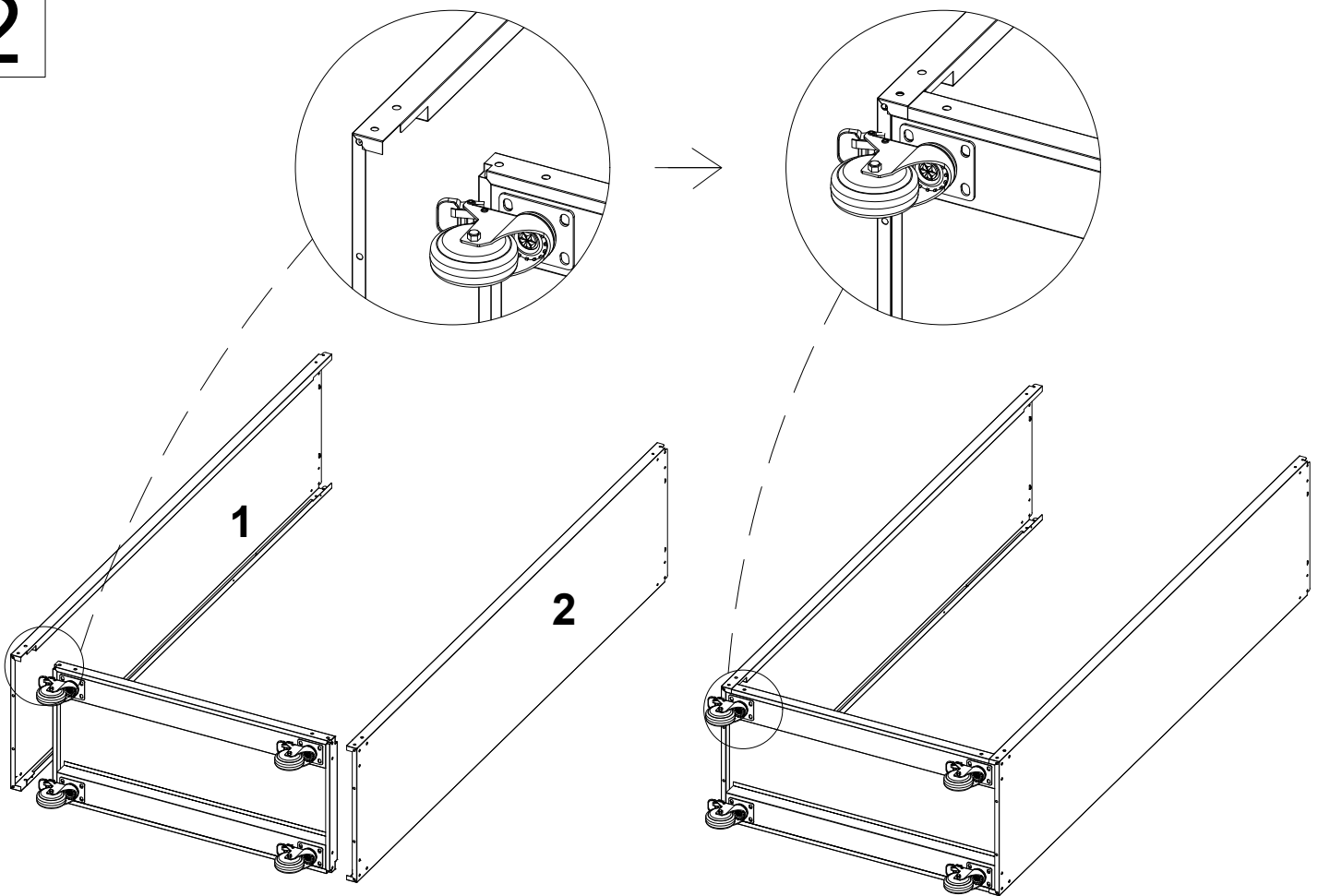

3

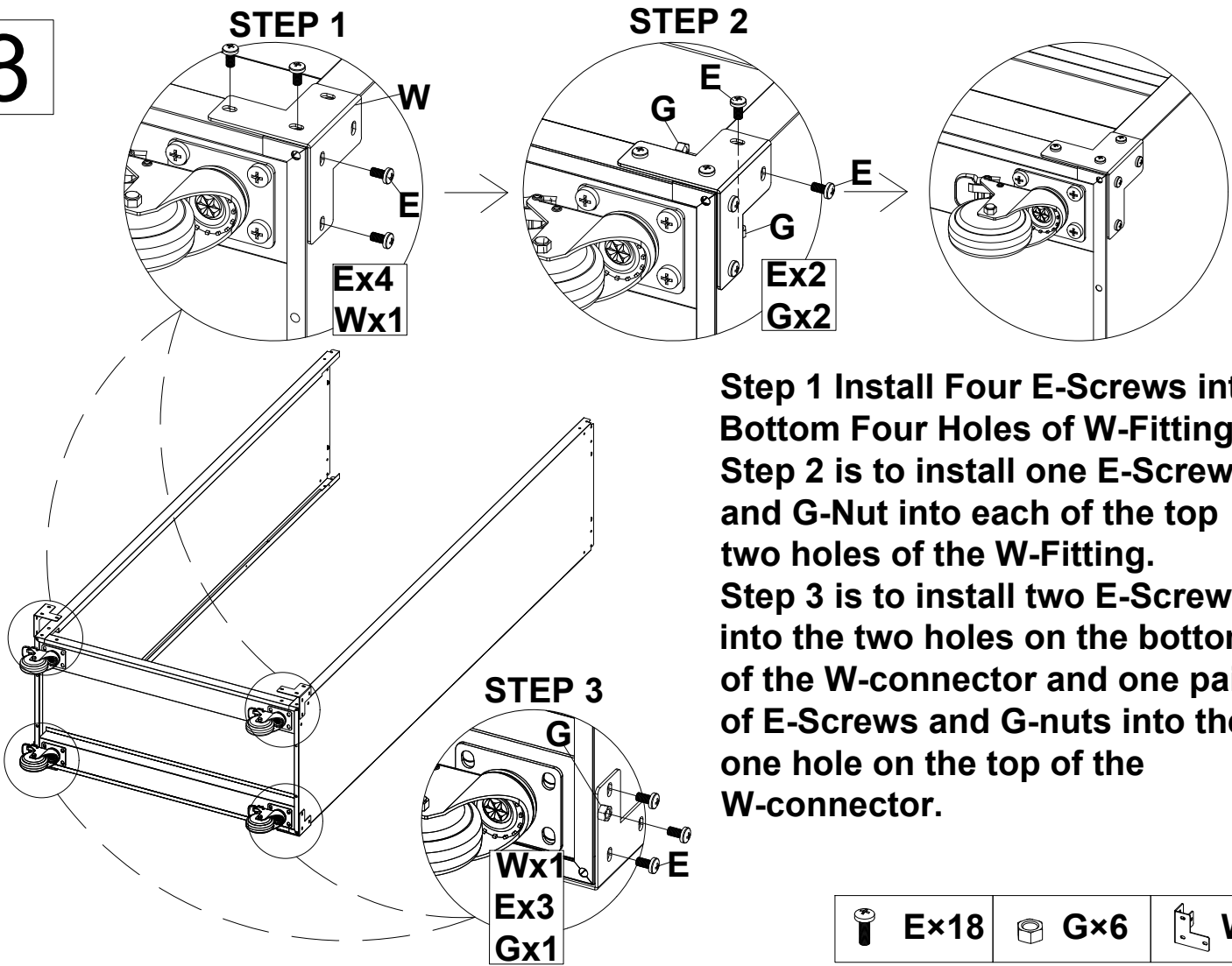

4

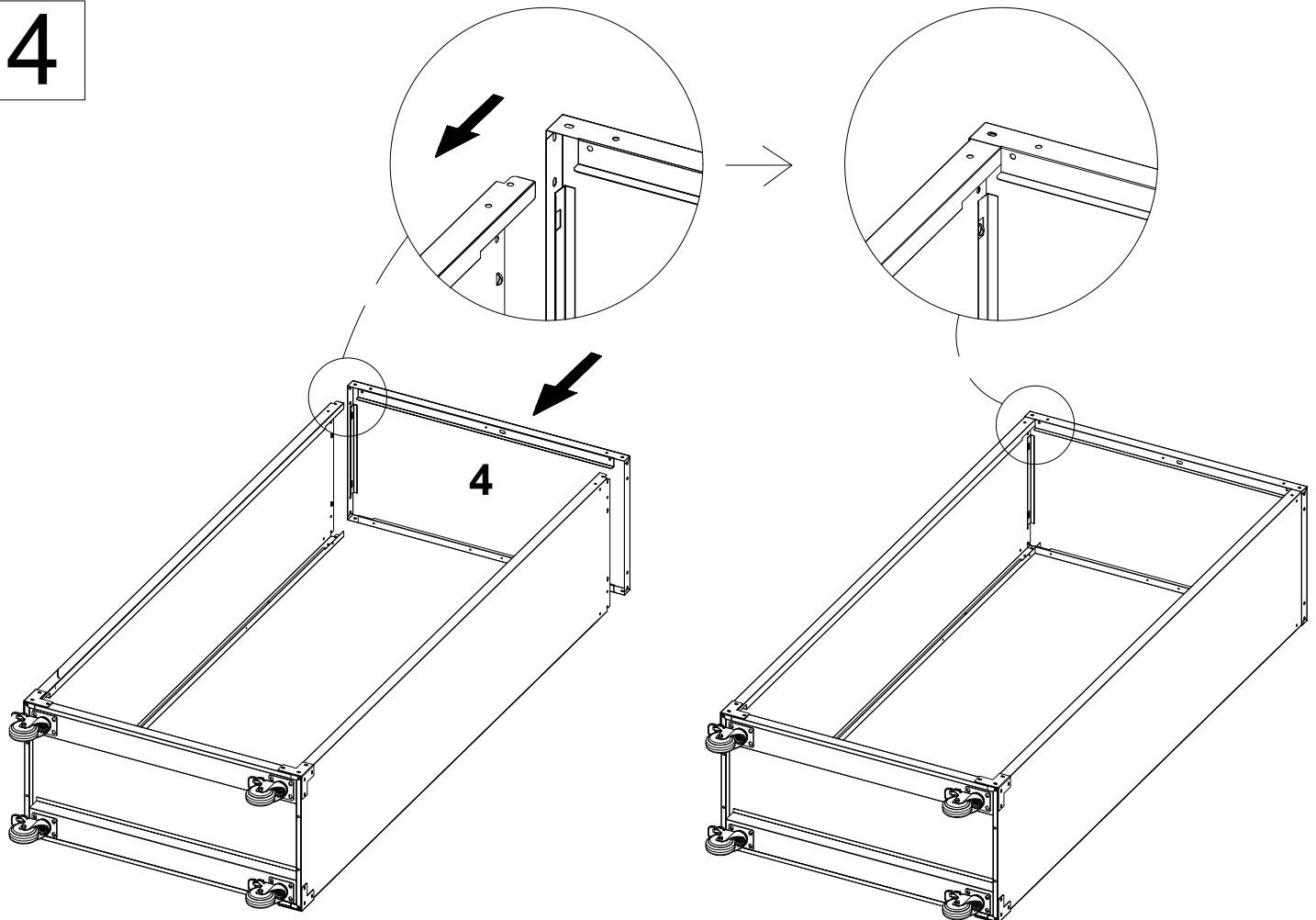

5

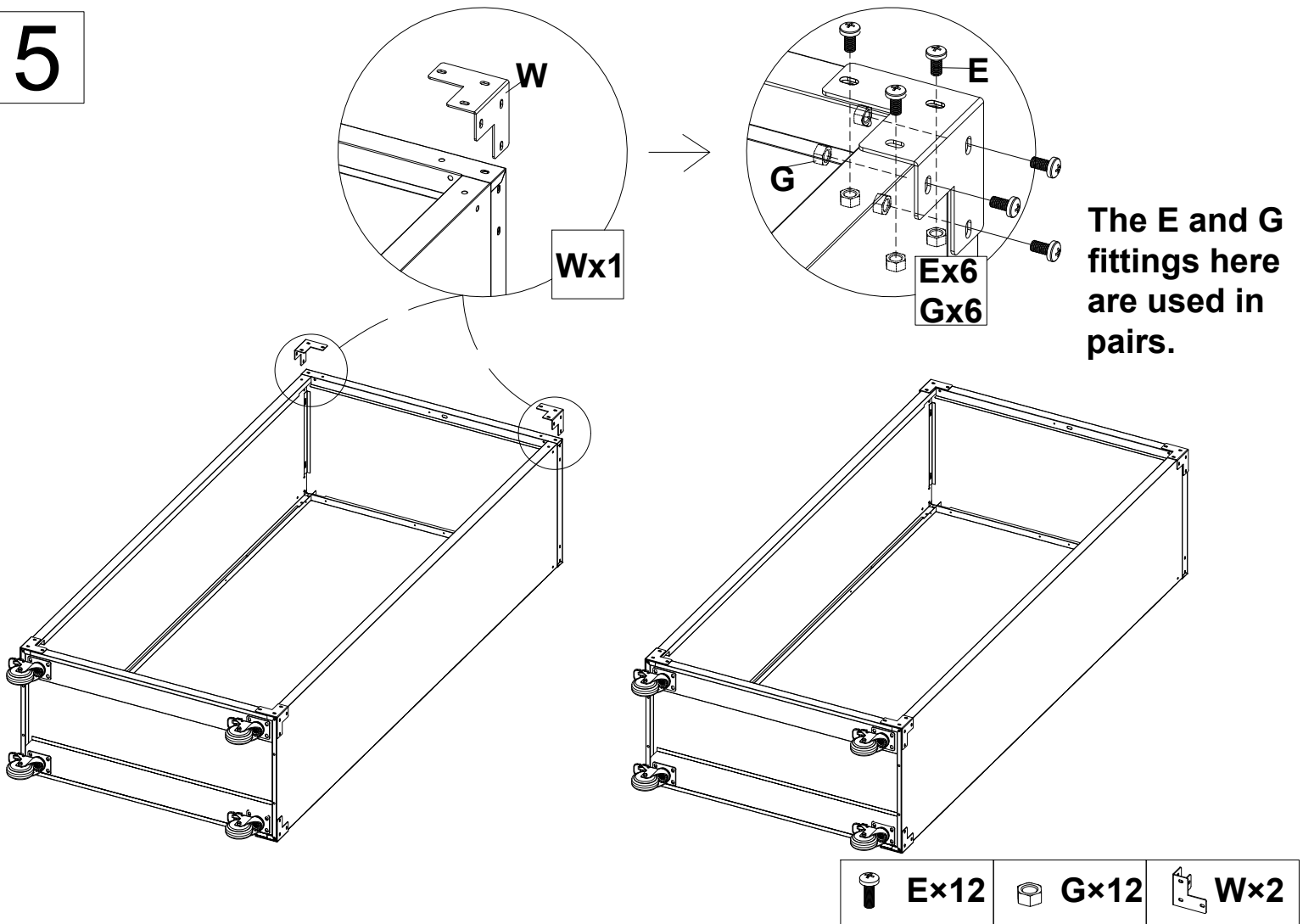

6

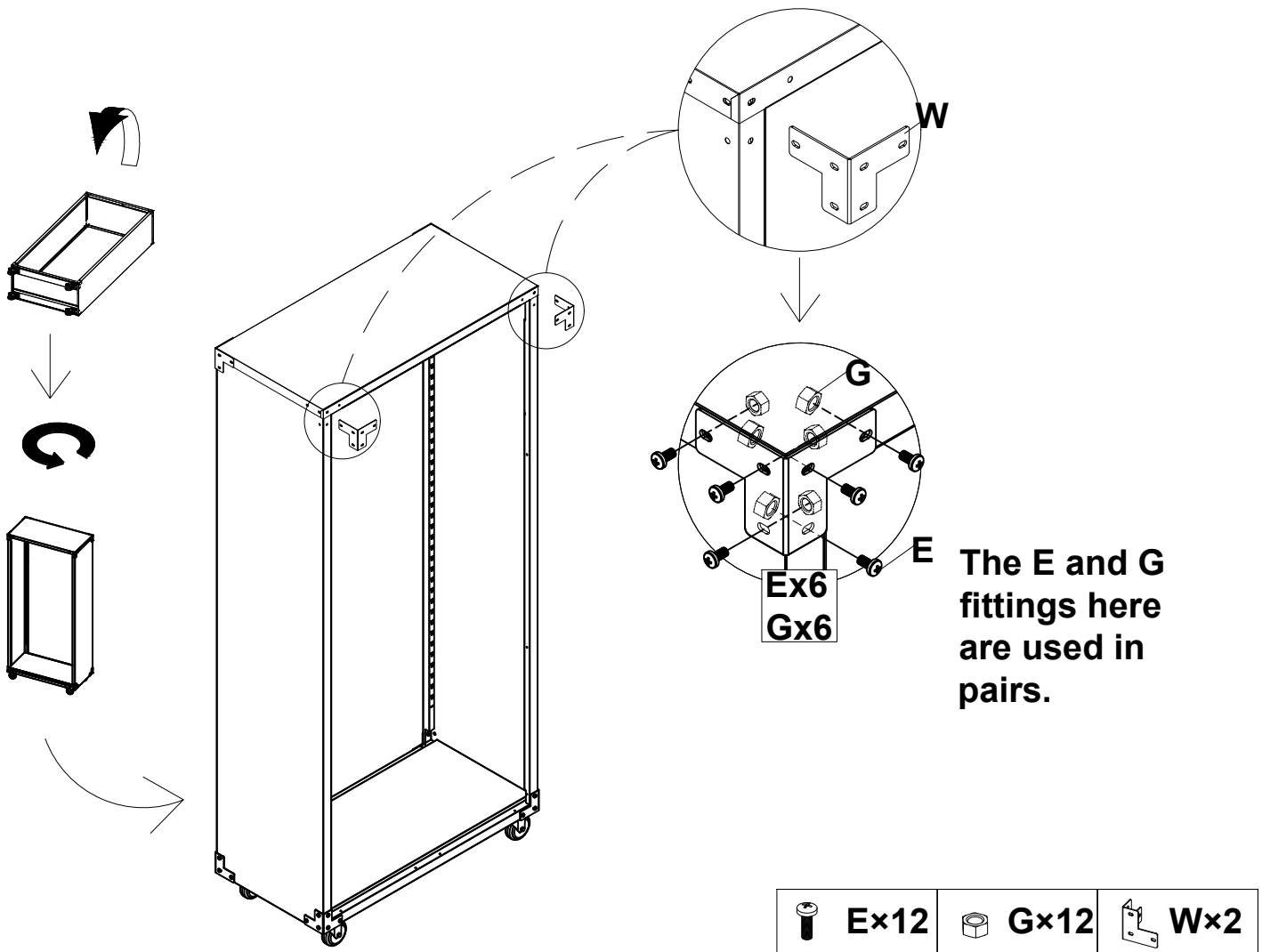

7

STEP 1

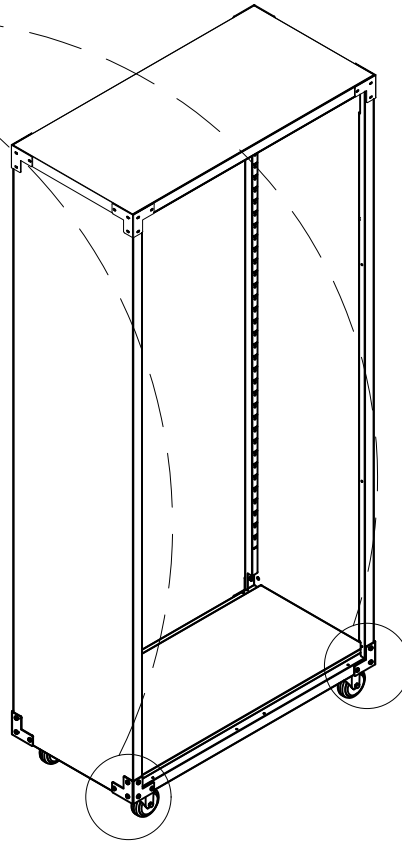
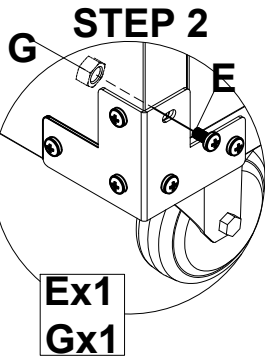
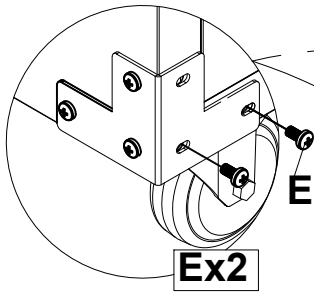

Step 1 starts with installing the two E screws to the bottom of the W fitting step 2 installs to the top of the W fitting using the E screws and G nuts.



E×6



G×2

8

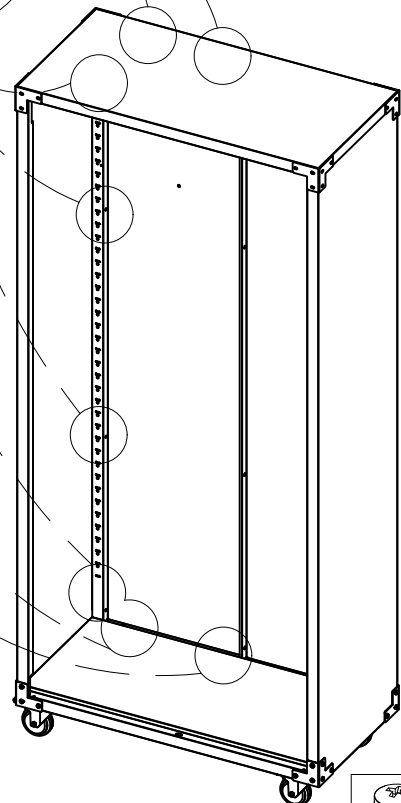
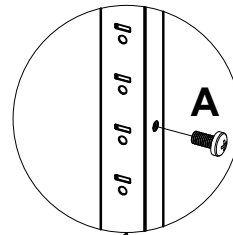
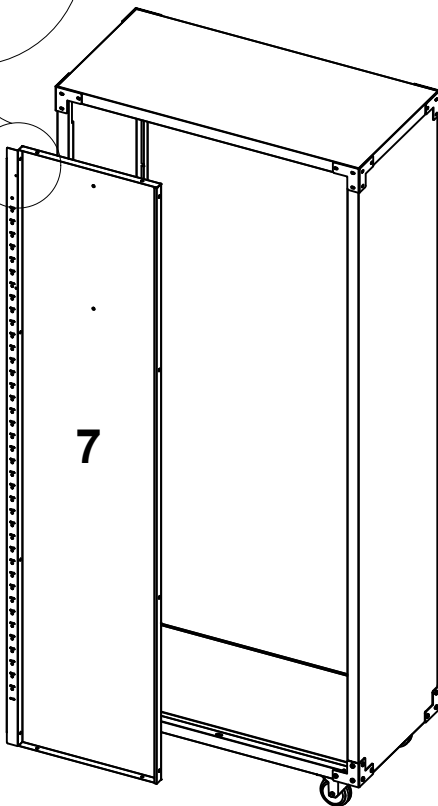
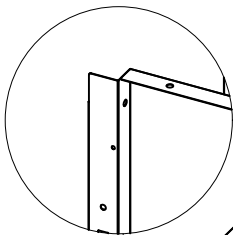

A×8

9

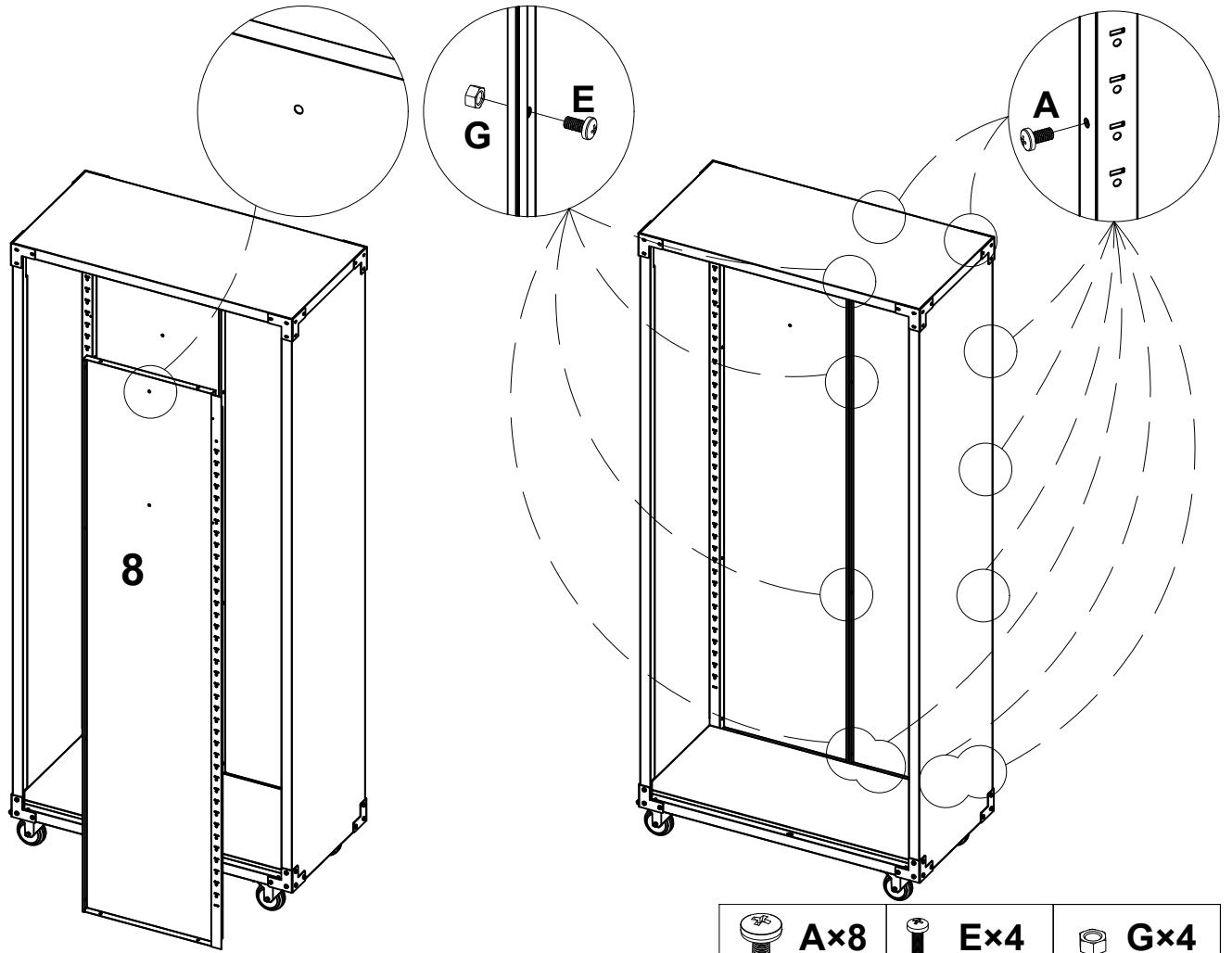

10

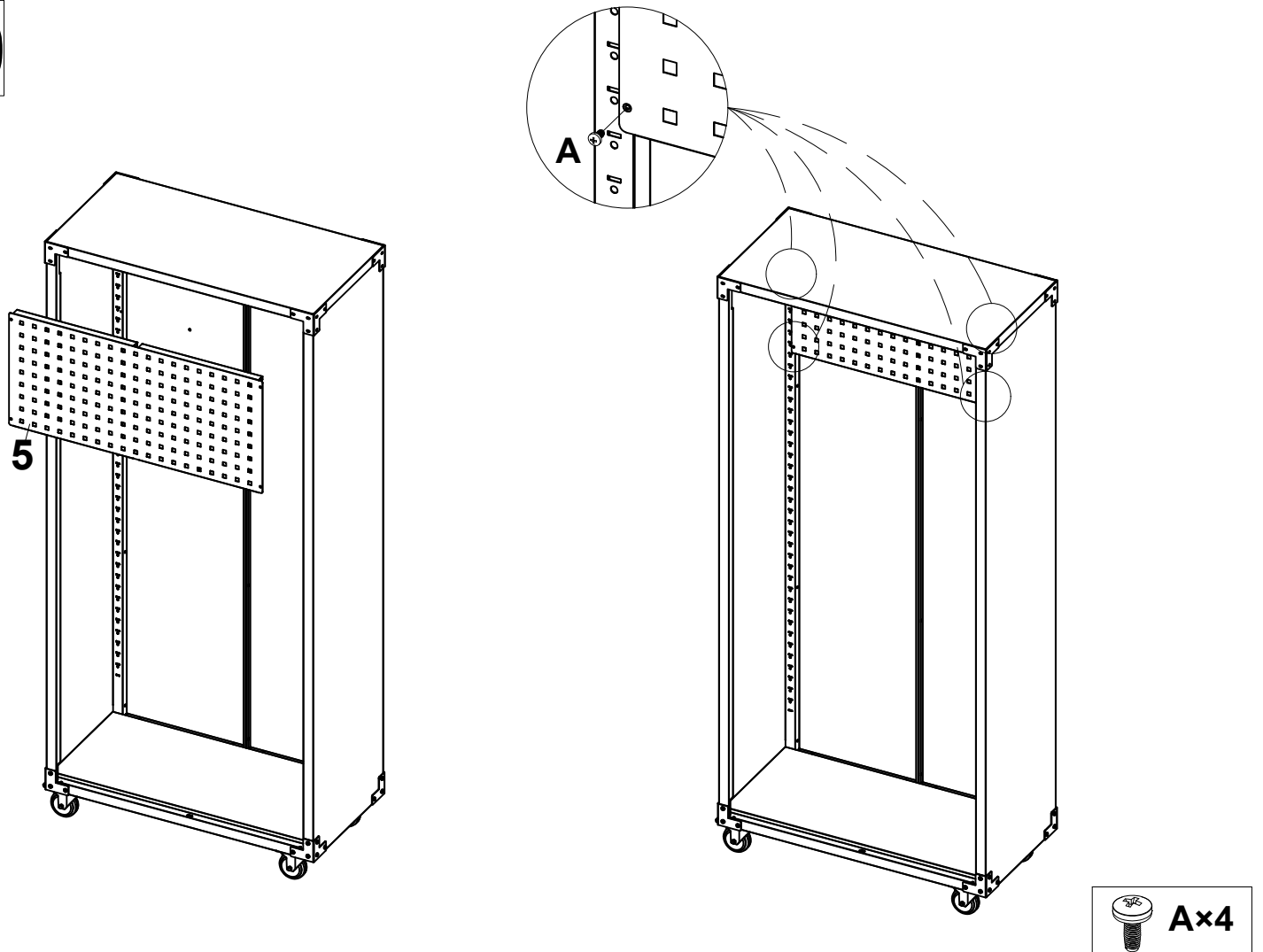

11

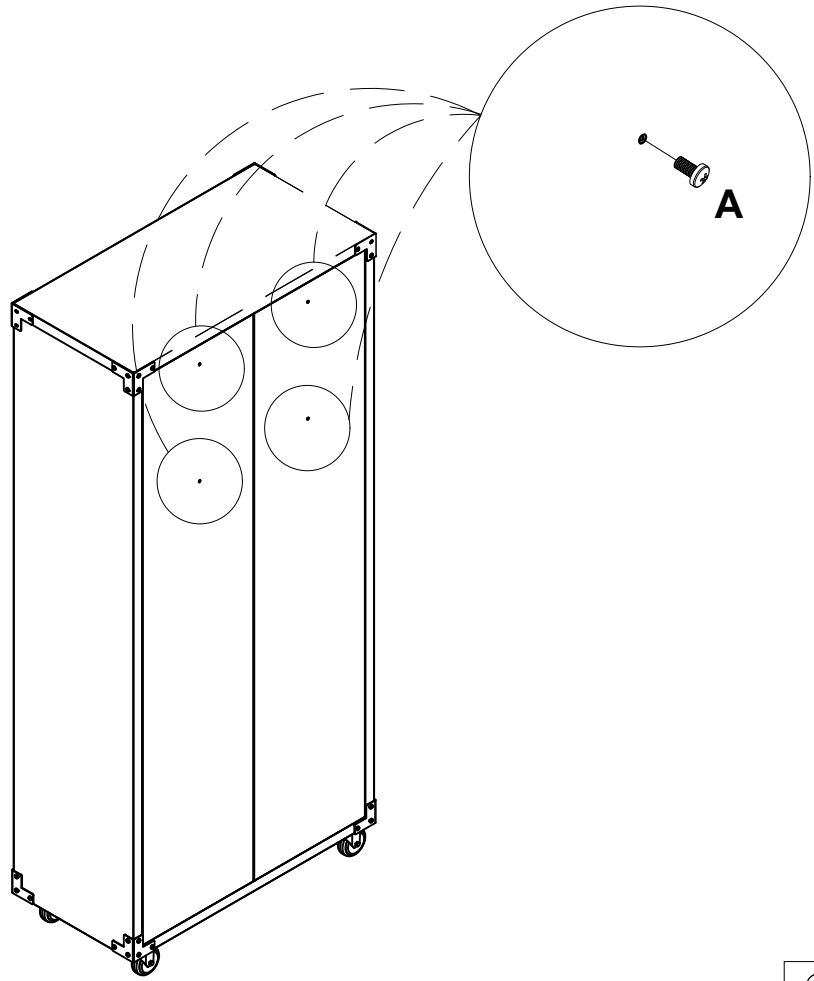
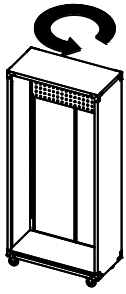

12

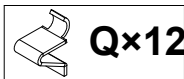
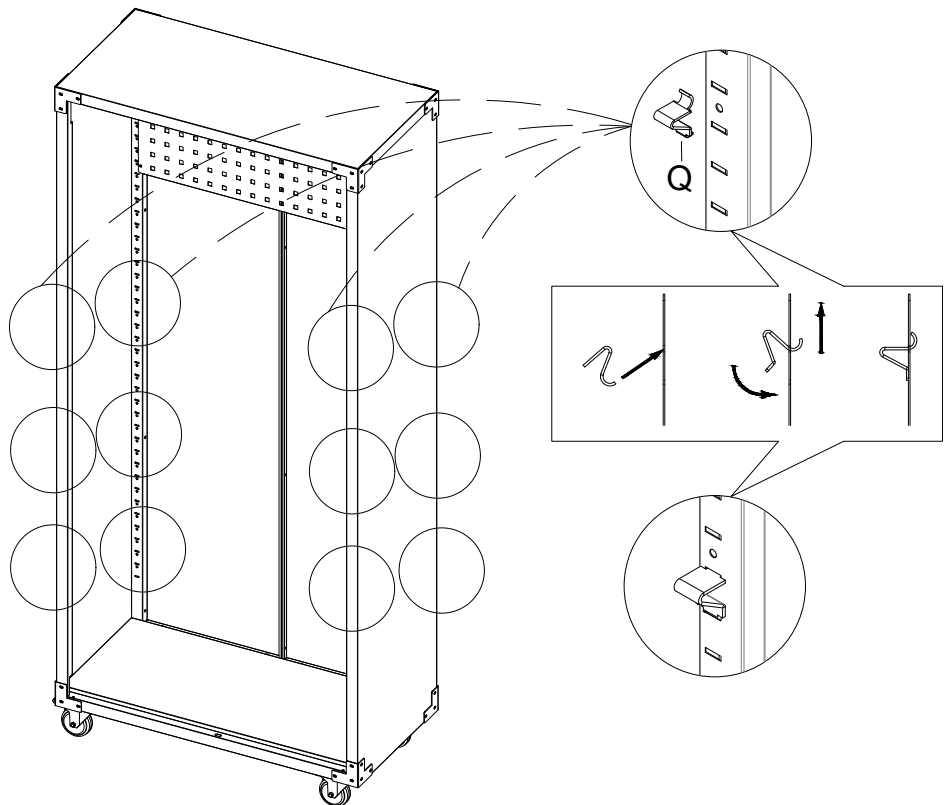
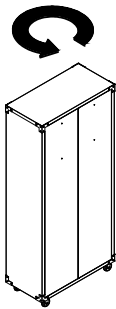

13

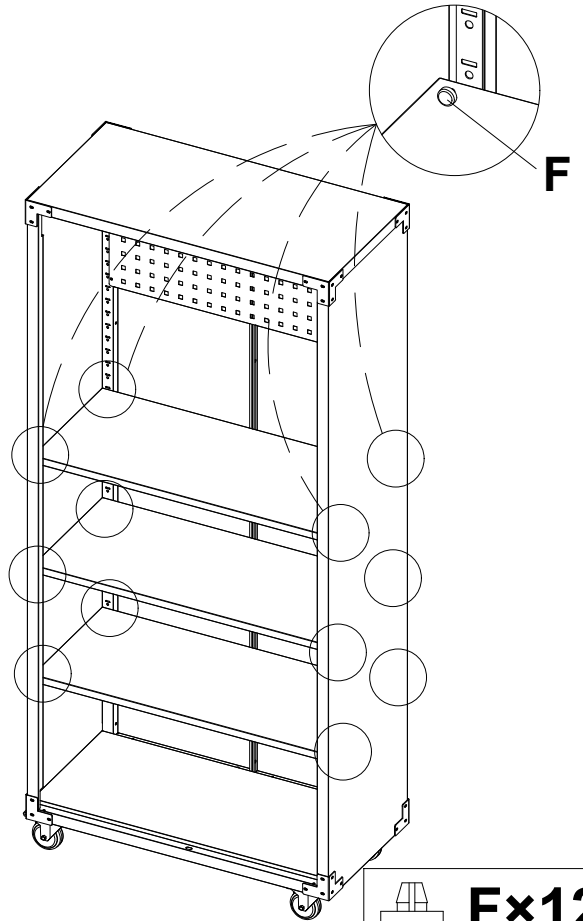
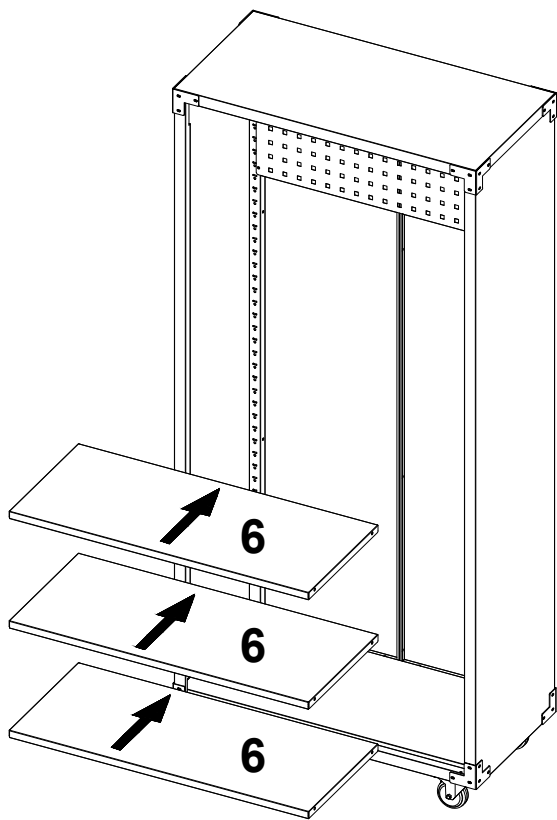

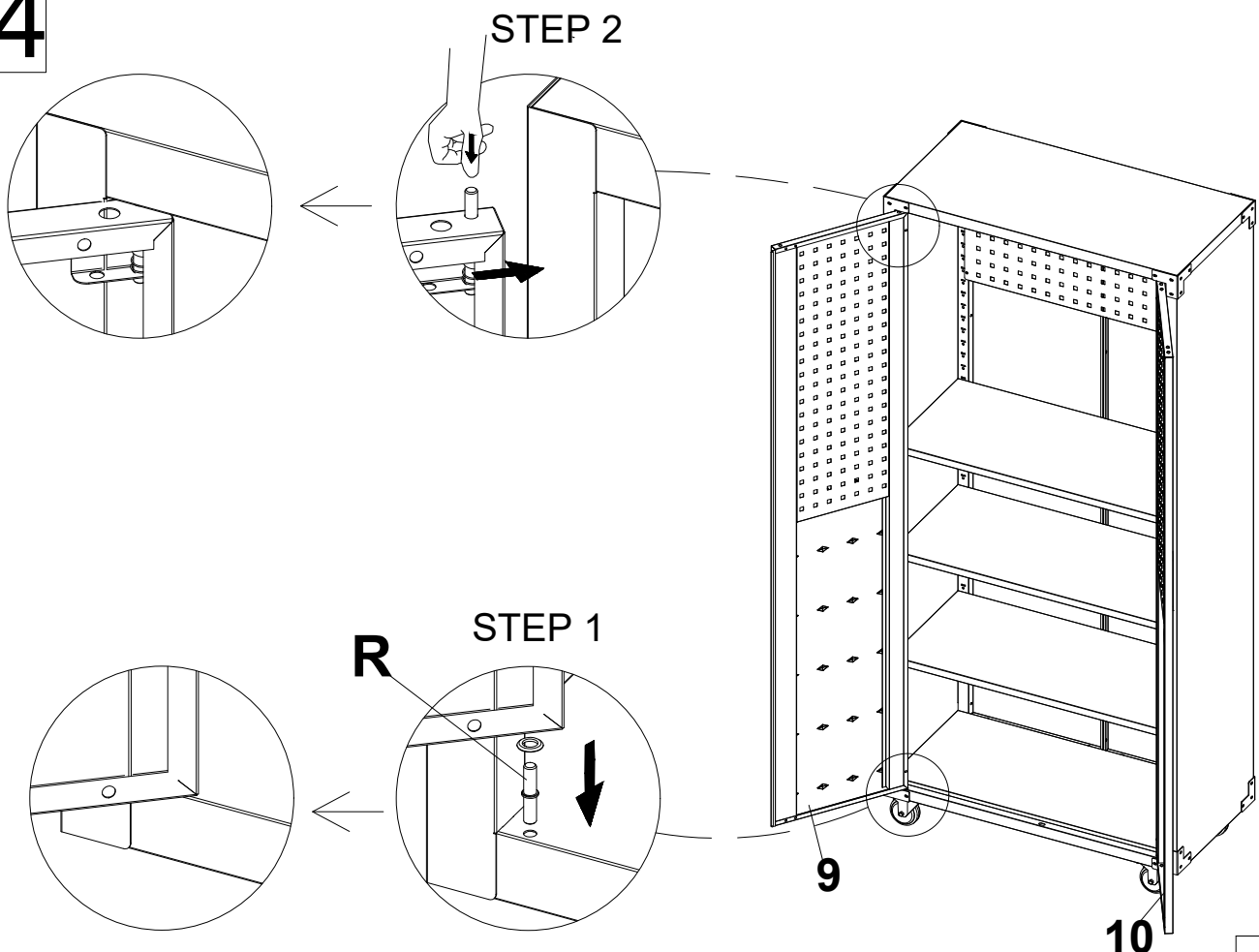

14

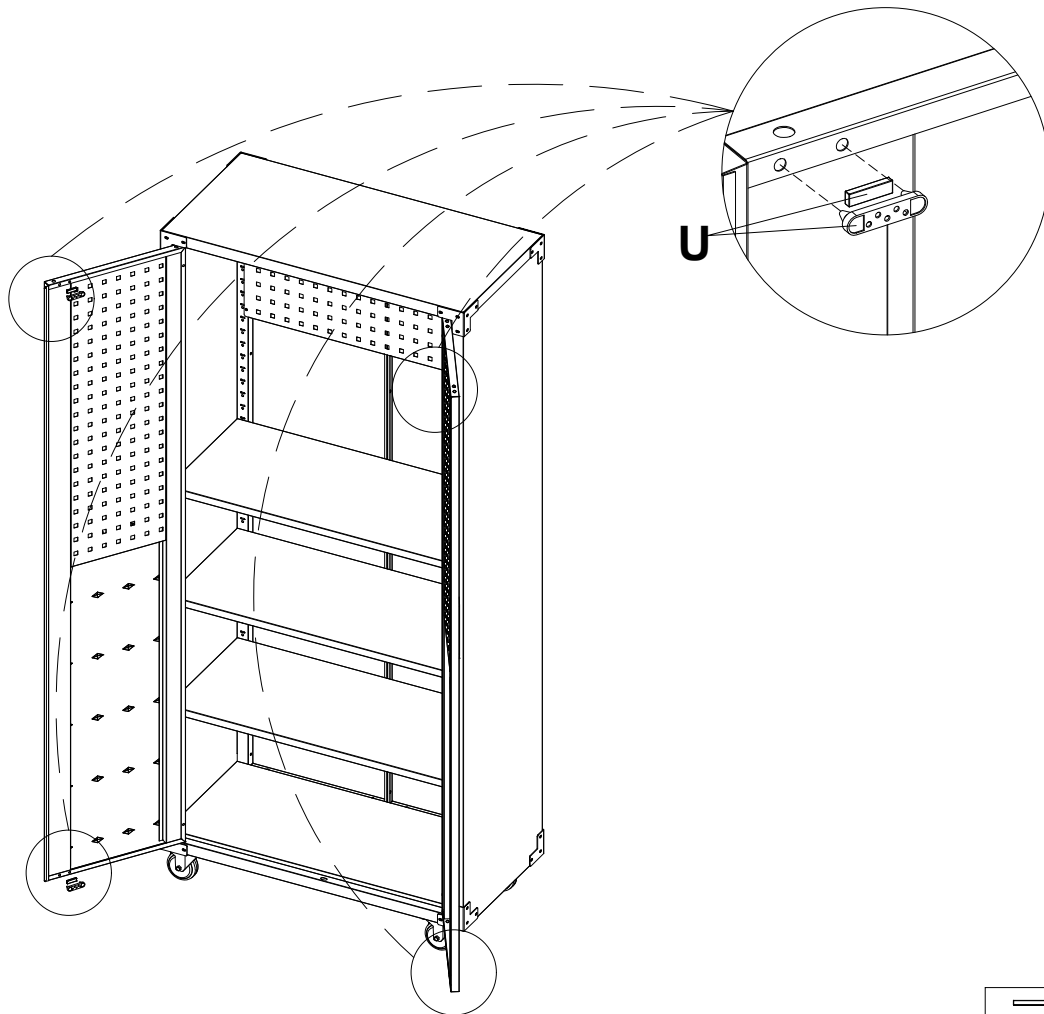

R x 2

15



 **Ux4**

16

