



furnishing better lives together[®]

WWW.JOFRAN.COM





ASSEMBLY INSTRUCTIONS & PARTS IDENTIFICATION

MODEL # 2545-HTBASE & #2545-HTTOP

WESTPORT WHITE HALL TREE BASE

WESTPORT WHITE HALL TREE TOP

Thank you for purchasing this quality product. Be sure to check all packing material carefully for small parts that may have come loose inside the carton during shipment.

Parts key				Table Hardware kit # 2545-HTTOP01			
No	Code	Qty	Description	No	Description		Qty
1	2545-HTBP05	2 Pcs	Drawers	A		Bolt M6 x 40	4 pcs
2	2545-HTBP02	4 Pcs	Legs	B		Lock washer M6	8 pcs
3	2545-HTBP01F	4 Pcs	Floor glide	C		Flat washer M6 x 13	8 pcs
4	2545-HTBP08	1 Pc	Shelf	D		Allen Key K4	01 pc
5	2545P08P	4 Pcs	Shelf pin	E		Bolt M6 x 30	4 pcs
6	2545P01AT	2 Kits	Anti-tip kit	9	2545-HTP04A	Pull w/Screw	2 pcs
7	2545-HTBP06	4 Pcs	Extension Drawer Glide	10	2545-HTT01MH	Metal Hook	4 pcs
8	2545-HTTP29	1 Set	Attachment Bracket				

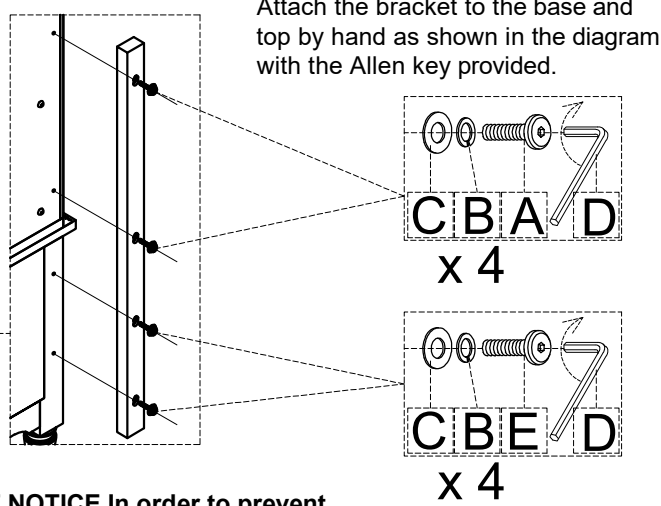
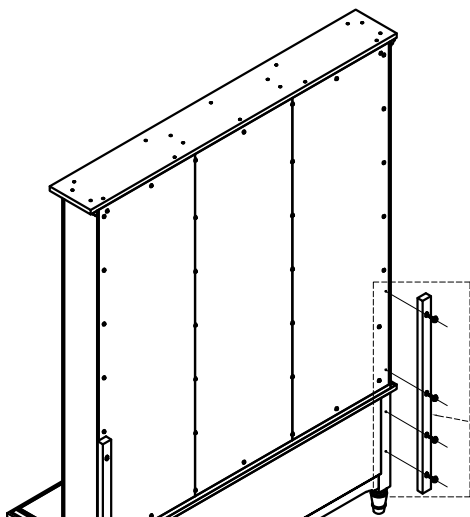

IMPORTANT NOTICE In order to prevent tip-over, the Anti-Tip hardware must be installed.

