

Thank you for purchasing this quality product. Please be sure to check all packing material carefully for small parts which may have come loose inside the carton during shipment. Count all parts and hardware and compare with the parts list to be sure all parts are present. If any parts are missing or damaged, phone, fax or email to our Customer Service Department. For efficient and speedy service please indicate the model number and code letter of part(s) needed.

If you have any damaged or missing parts please contact us

IMPORTANT NOTE: Follow instructions listed below in proper sequence as numbered to assure fast, easy and correct assembly.

hardware

(V) x 28
Wood dowel
Ø7.8 X 30mm

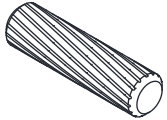

(W) x 23
Cam bolt (large)



(X) x 23
Cam (large)



(Y) x 2
Fabric strap

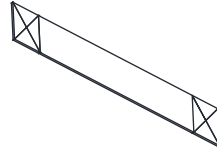

(Z) x 4
Metal washer

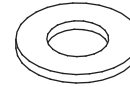

(Aa) x 2
Screw Ø4 X 14mm

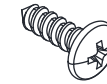

(Bb) x 1
Plastic plug

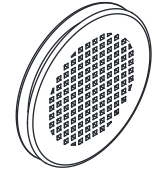

(Cc) x 4
Screw Ø5 X 50mm

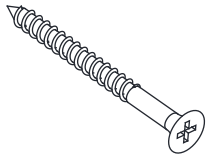

(Dd) x 3
Screw Ø4 X 25mm



(Ee) x 1
Metal slide (left)

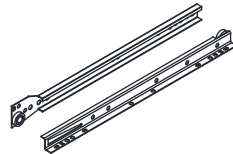

(Ff) x 1
Metal slide (right)

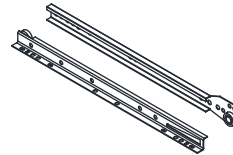

(Gg) x 12
Screw Ø3.5 X 12mm



(Hh) x 1
Magnet

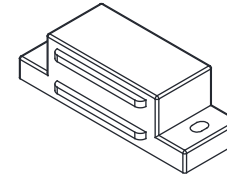

(Ii) x 16
Screw Ø3 X 16mm

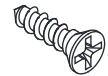

(Jj) x 4
Hinge

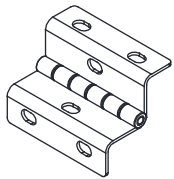

(Kk) x 2
Screw Ø3 X 12mm



(Ll) x 14
Plastic connector



(Mm) x 3
Handle



(Nn) x 3
Screw M4 x 20mm



(Oo) x 2
Metal plate



(Pp) x 4
Shelf pin

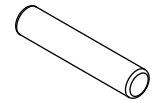

(Qq) x 2
Cam bolt (small)



(Rr) x 2
Cam (small)



(Ss) x 6
Screw Ø3.8 X 35mm

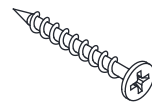

(Tt) x 2
Wood dowel
Ø5.8 X 30mm

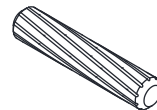

(Uu) x 8
Plastic cover



(Vv) x 2
Wall anchor



(Ww) x 2
Glue



(Xx) x 24
Screw Ø3.5 X 12mm

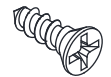

ITEM DESCRIPTION QUANTITY

A	Upper left side panel	1
B	Upper right side panel	1
C	Top	1
D	Upper back panel	1
E	Fixed shelf	1
F	Trim	1
G	Lower left side panel	1
H	Lower right side panel	1
I	Drawer strip	1
J	Bottom	1
K	Toe kick	1
L	Left side rail	1
M	Right side rail	1
N	Lower back panel	1
O	Door panel	2
P	Adjustable shelf	1
Q	Left drawer side	1
R	Right drawer side	1
S	Drawer back	1
T	Drawer face	1
U	Drawer bottom	1
V	Wood dowel Ø7.8 X 30mm	28
W	Cam bolt (large)	23
X	Cam (large)	23
Y	Fabric strap	2
Z	Metal washer	4
Aa	Screw Ø4 X 14mm	2
Bb	Plastic plug	1
Cc	Screw Ø5 X 50mm	4
Dd	Screw Ø4 X 25mm	3
Ee	Metal slide (left)	1
Ff	Metal slide (right)	1
Gg	Screw Ø3.5 X 12mm	12
Hh	Magnet	1
Ii	Screw Ø3 X 16mm	16
Jj	Hinge	4
Kk	Screw Ø3 X 12mm	2
Ll	Plastic connector	14
Mm	Handle	3
Nn	Screw M4x20mm	3
Oo	Metal plate	2

Pp	Shelf pin	4
Qq	Cam bolt (small)	2
Rr	Cam (small)	2
Ss	Screw Ø3.8 X 35mm	6
Tt	Wood dowel 5.8 X 30mm	2
Uu	Plastic cover	8
Vv	Wall anchor	2
Ww	Glue	2
Xx	Screw Ø3.5 X 12mm	24

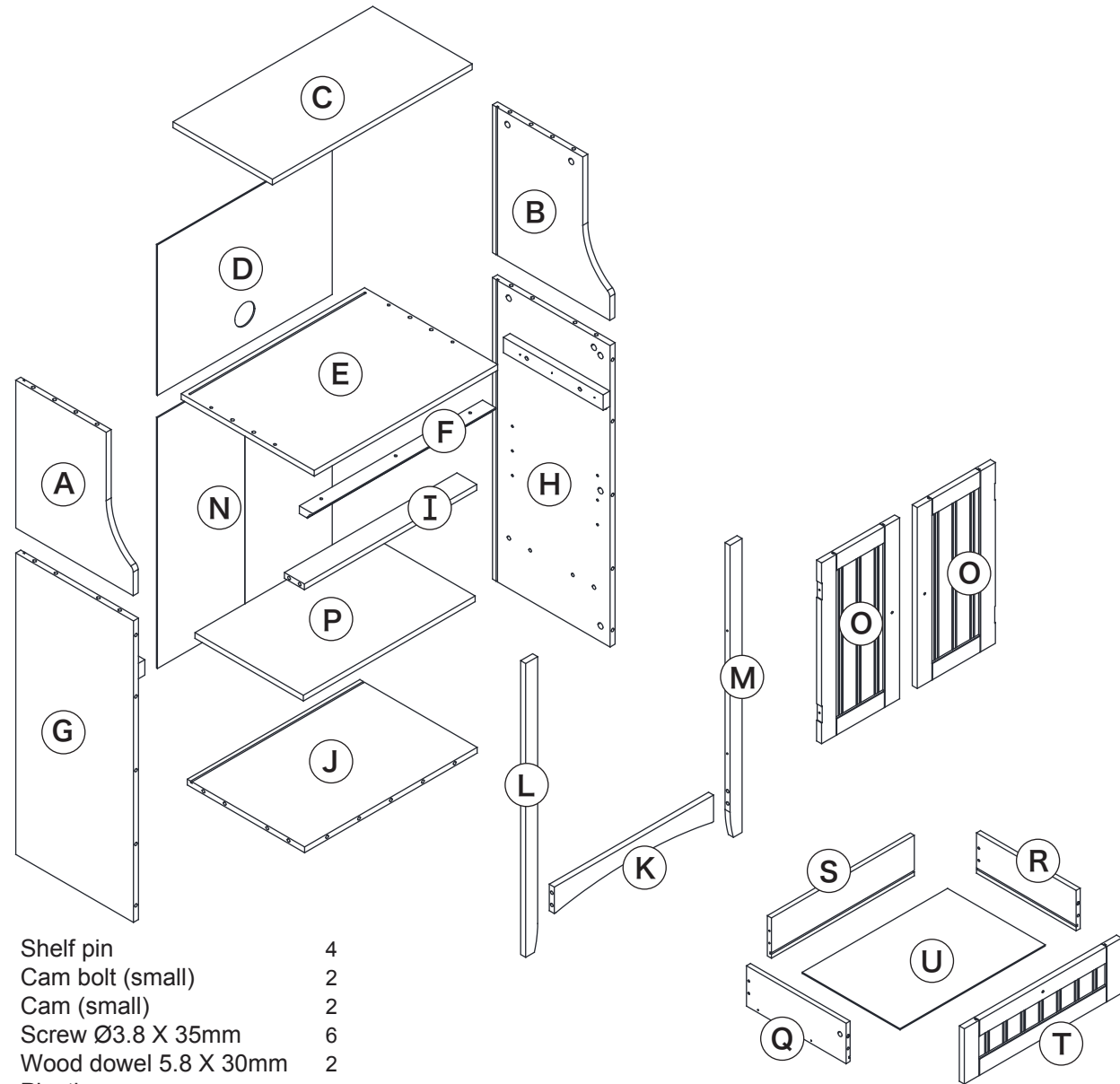

how to use the cam lock system

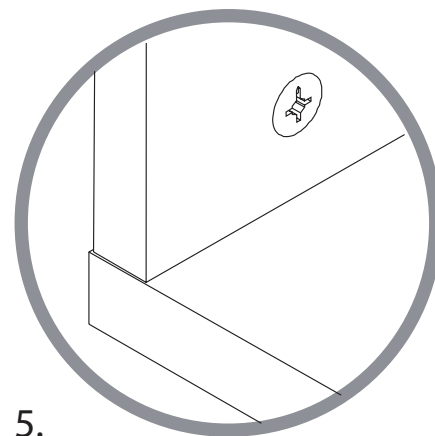
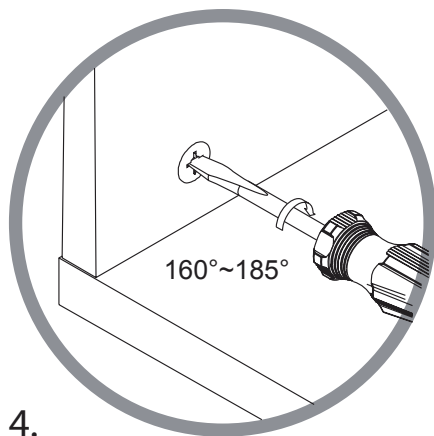
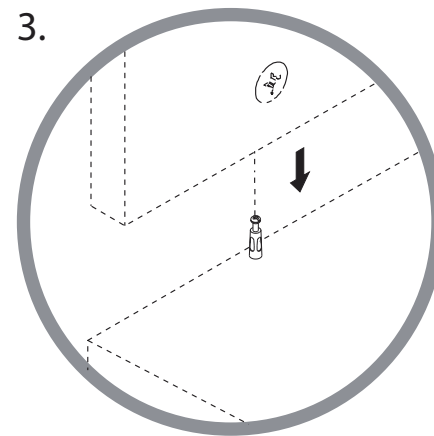
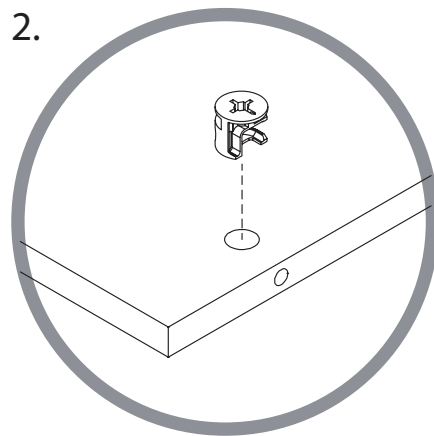
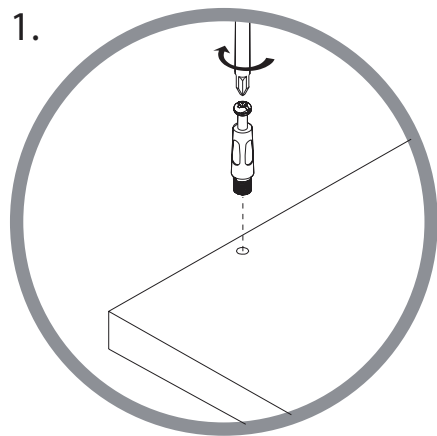

step 1.

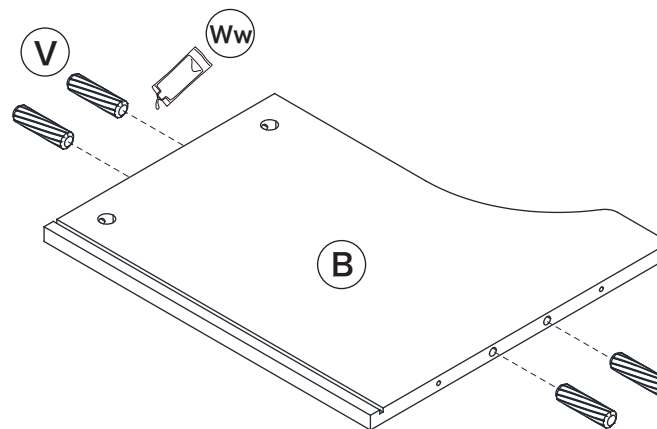
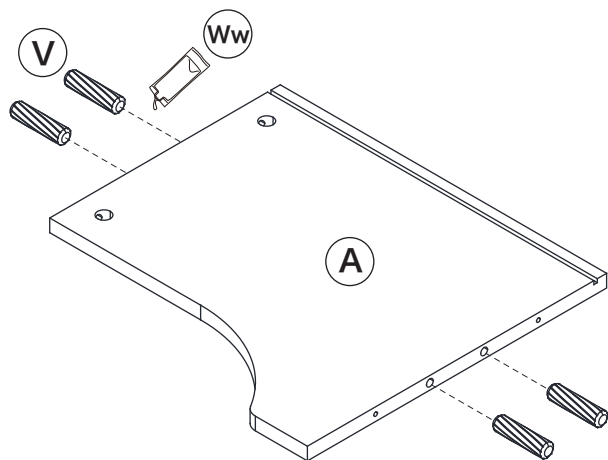

(V) x 8
Wood dowel
Ø7.8 X 30mm



(Ww)
Glue

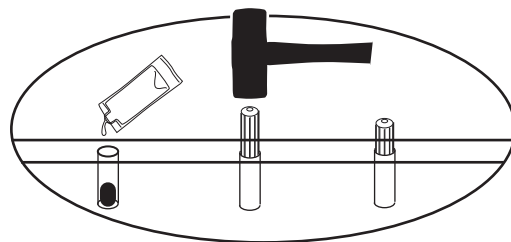

1. Instill the glue (Ww) to the wood dowel hole as image shown.
2. Insert the wood dowel (V) to the part (A), and (B).

step 2.

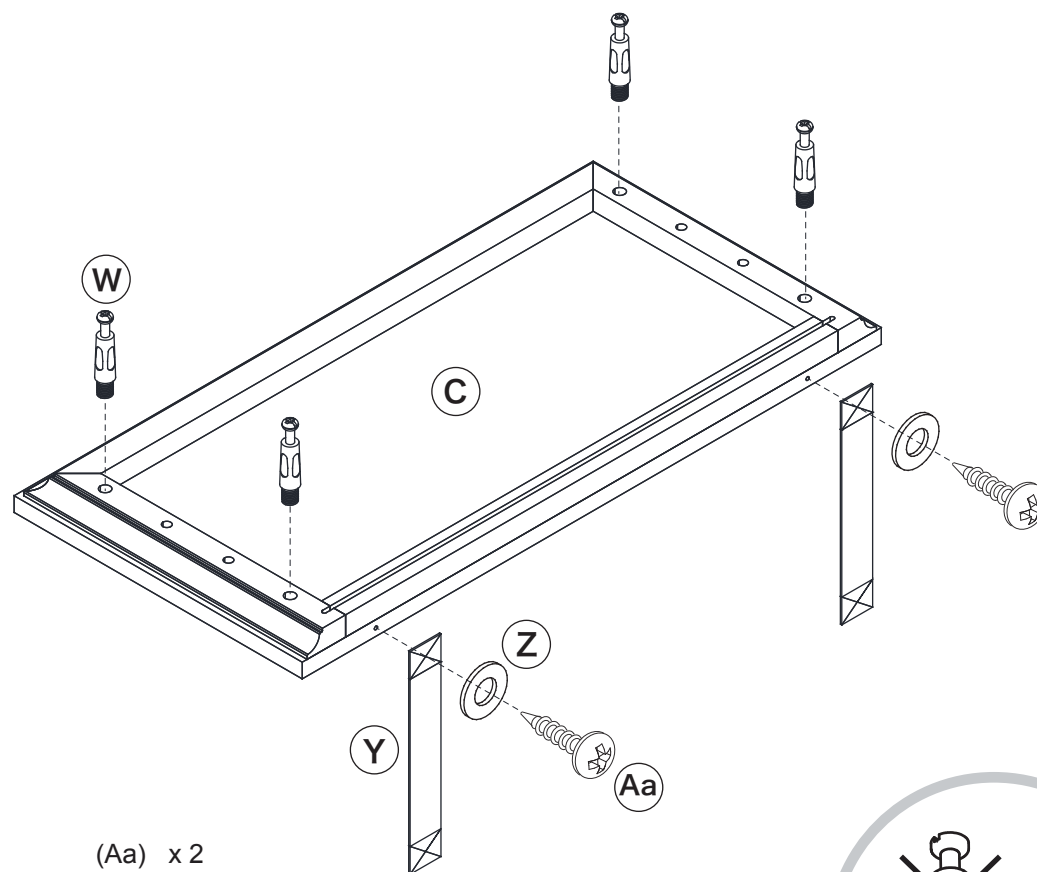

(W) x 4
Cam bolt



(Y) x 2
Fabric strap

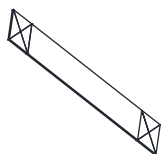

(Z) x 2
Metal washer

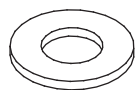

(Aa) x 2
Screw Ø4 X 14mm

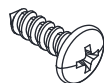

1. Insert the cam bolt (W) to the part (C).
2. Attach the fabric strap (Y) to the top panel (C) using metal washer (Z) and screw (Aa).

step 3.

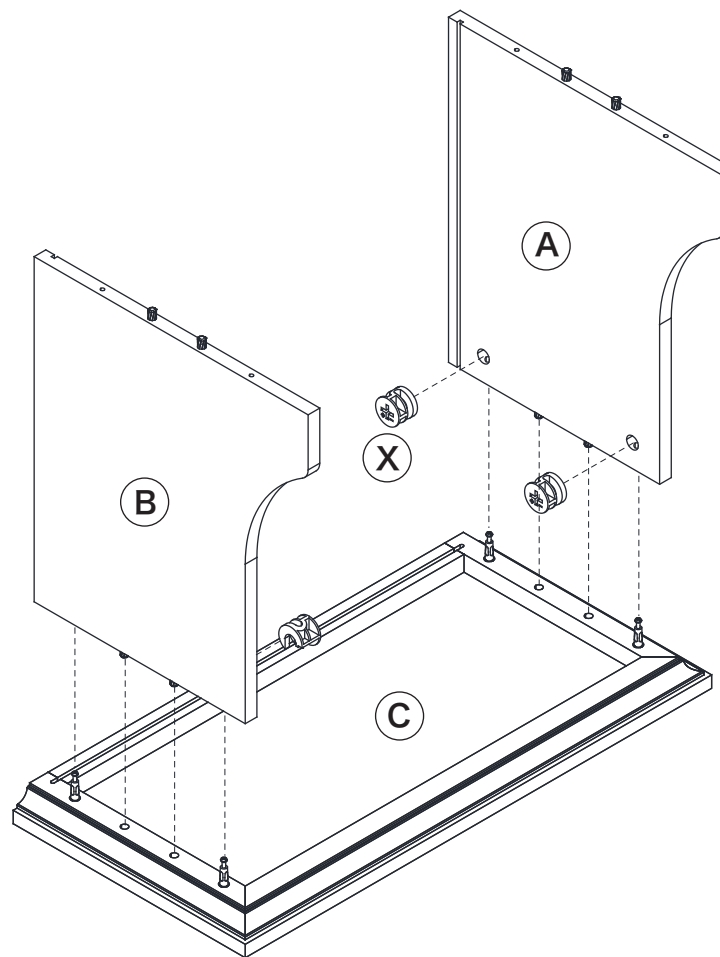
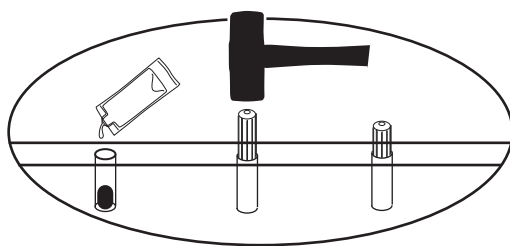

(X) x 4
Cam

(Ww)
Glue



1. Instill the glue (Ww) to the wood dowel hole as image shown.
2. Attach the two parts (A) and (B) together with part (C) as image shown.
3. Tighten all the parts using cam (X) as image shown.

step 4.

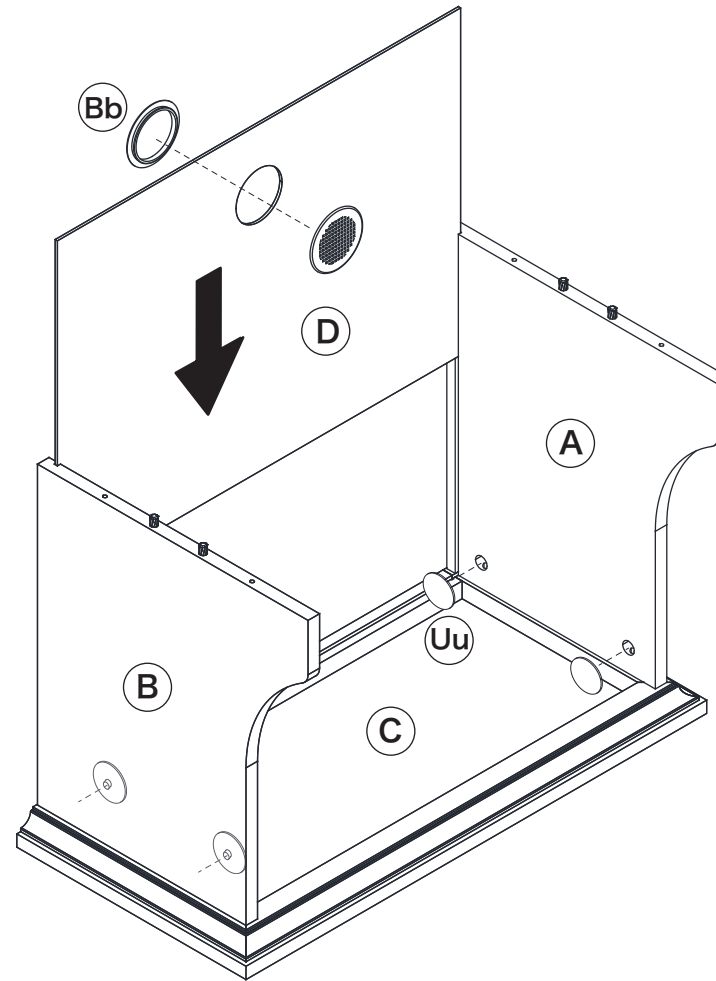
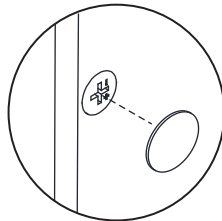
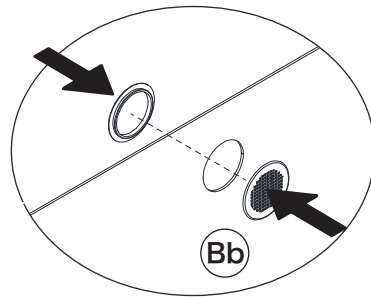

(Bb) x 1
Plastic plug

(Uu) x 4
Plastic cover

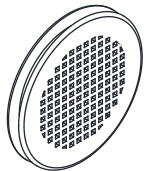

1. Insert the back panel (D) to the groove of parts (A), (B) and (C).
2. Insert the plastic plug (Bb) to the hole of back panel (D) as image shown.
3. Cover the cam holes using plastic cover (Uu).

step 5.

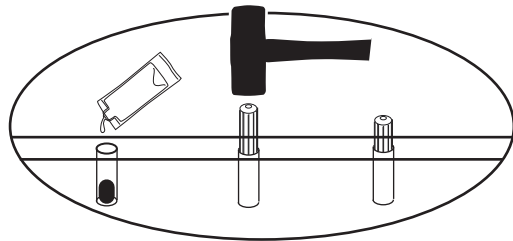

(Cc) x 4
Screw Ø5 X 50mm

(Ww)
Glue

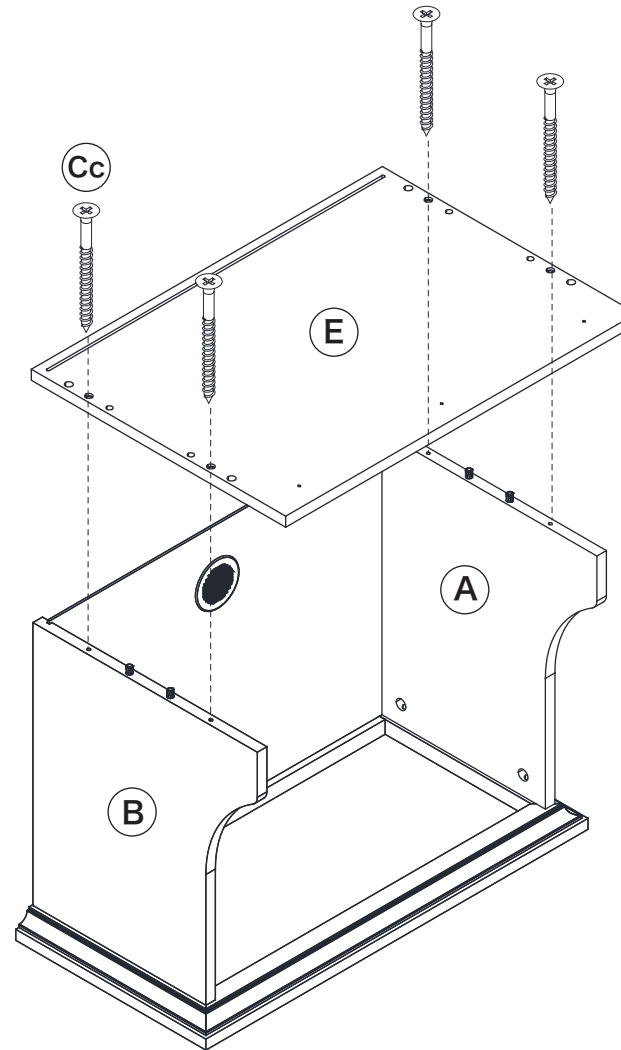
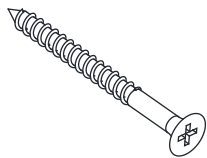

1. Instill the glue (Ww) to the wood dowel hole as image shown.
2. Attach the parts (E) together with the assembled parts using wood dowel (V) and screw (Cc) as image shown.

step 6.

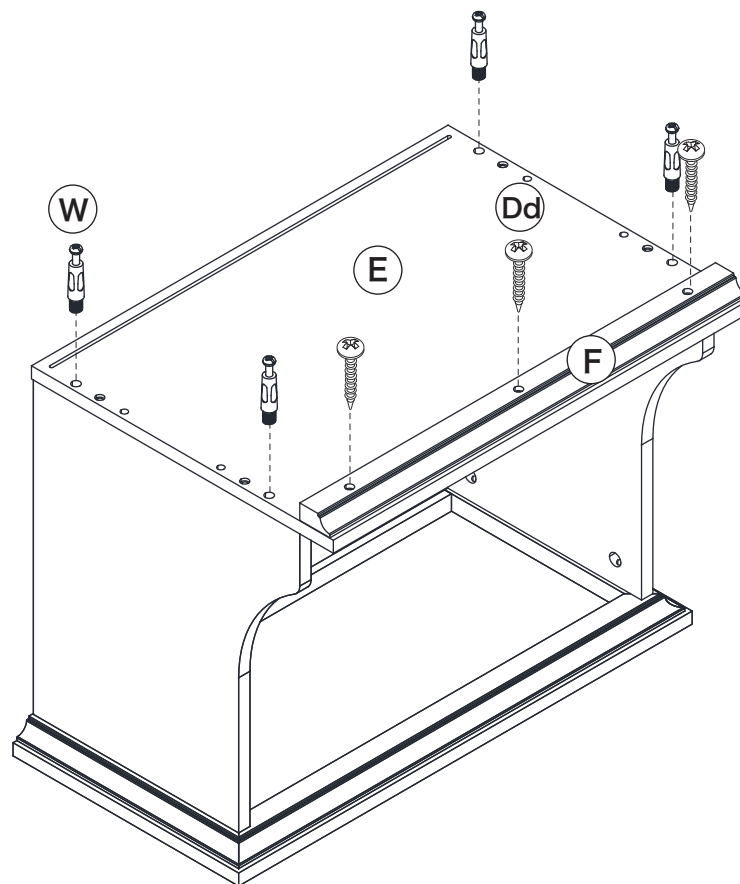

(W) x 4
Cam bolt

(Dd) x 3
Screw Ø4 X 25mm



1. Attach the part (F) to part (E) with screw (Dd).
2. Attached the cam bolt (W) to part (E).

step 7.

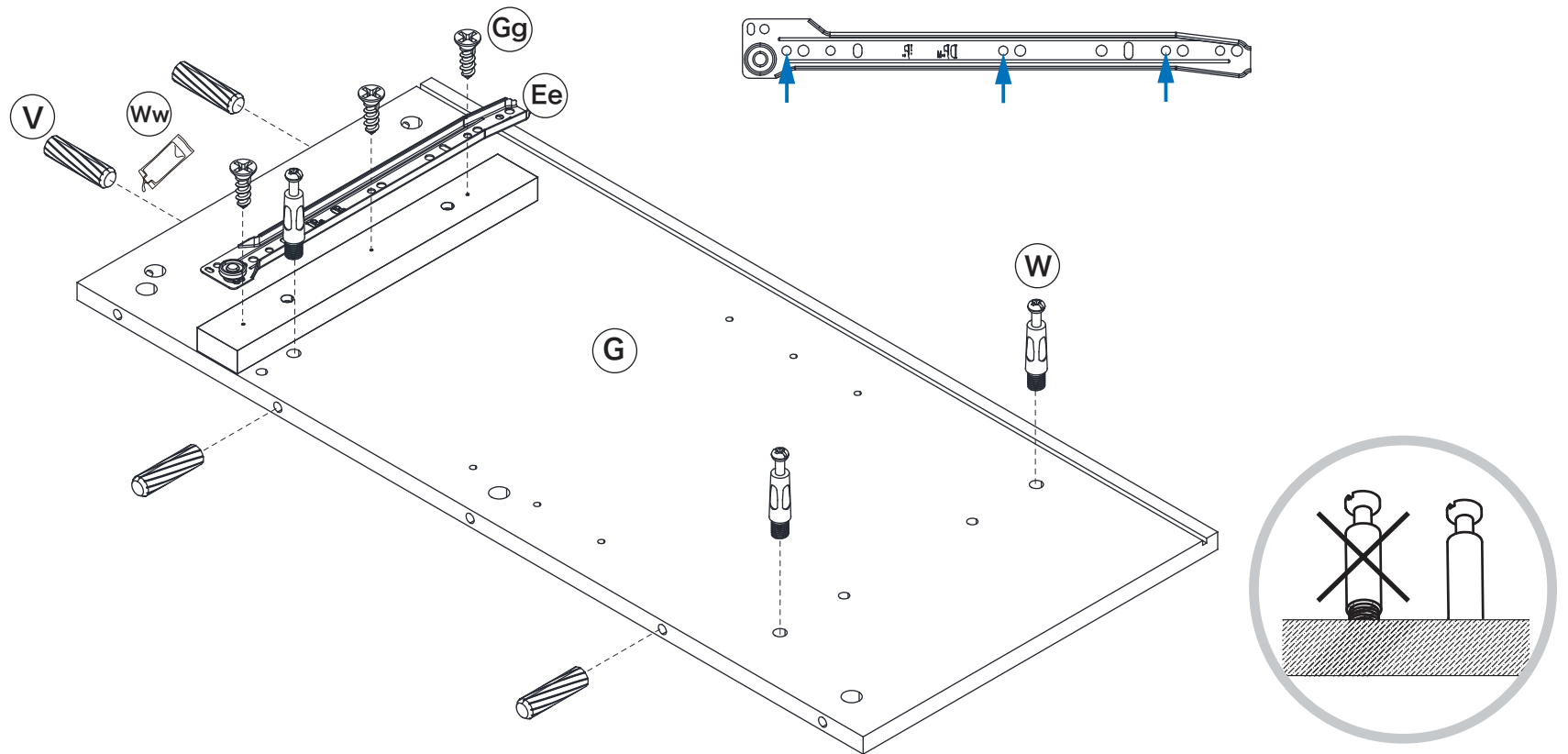

(V) x 4
Wood dowel
Ø7.8 X 30mm

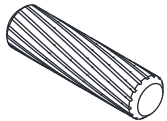

(W) x 3
Cam bolt



(Ee) x 1
Metal slide (left)

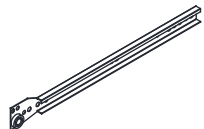

(Gg) x 3
Screw Ø3.5 X 12mm



(Ww)
Glue

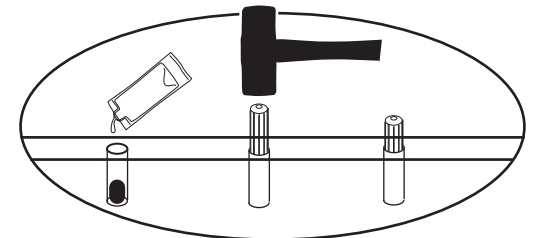

1. Instill the glue (Ww) to the wood dowel hole as image shown.
2. Insert the wood dowel (V) to the part (G).
3. Attached the cam bolt (W) to part (G).
4. Attach the metal slide (Ee) to the part (G) with screw (Gg).

step 8.

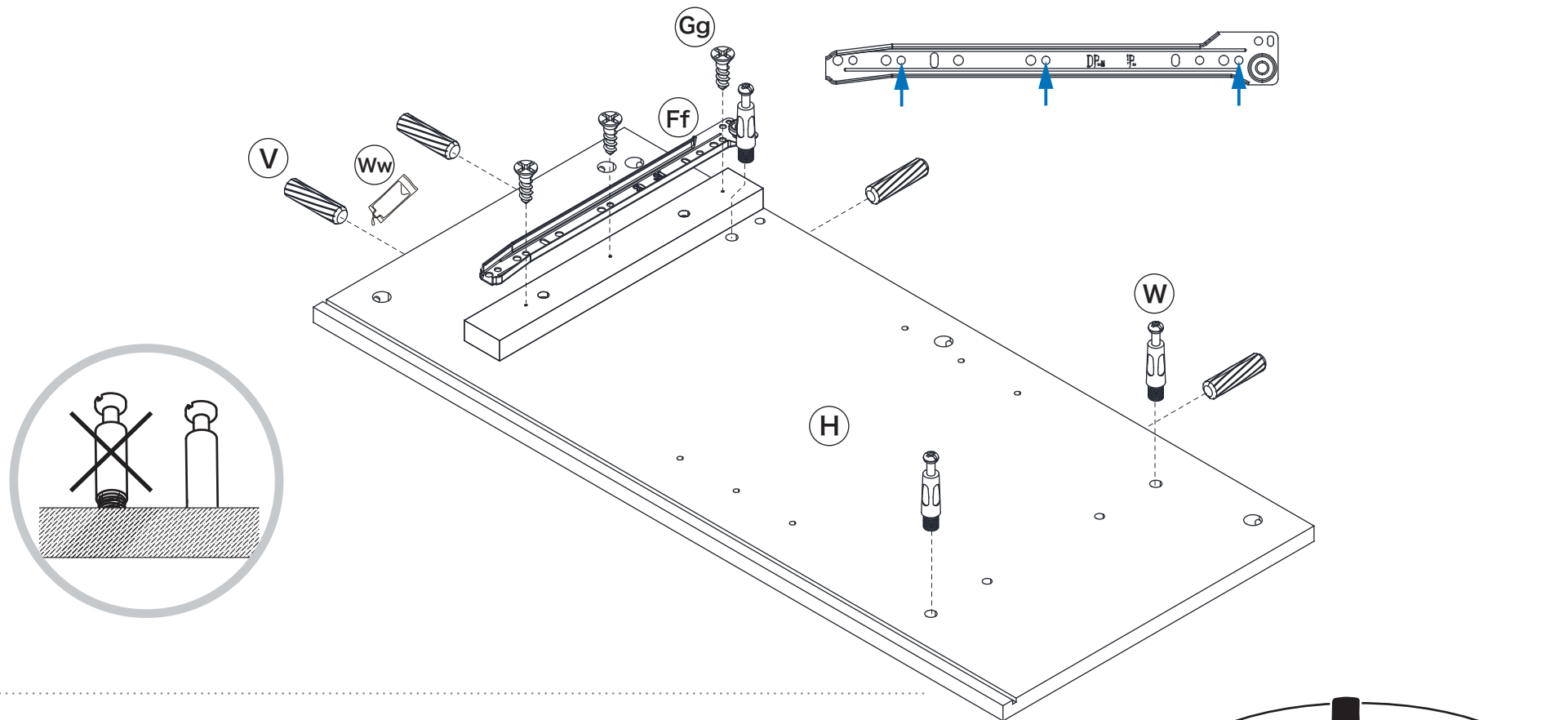

(V) x 4
Wood dowel
Ø7.8 X 30mm

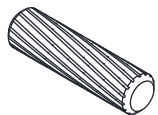

(W) x 3
Cam bolt



(Ff) x 1
Metal slide (right)

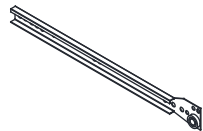

(Gg) x 3
Screw Ø3.5 X 12mm



(Ww) Glue

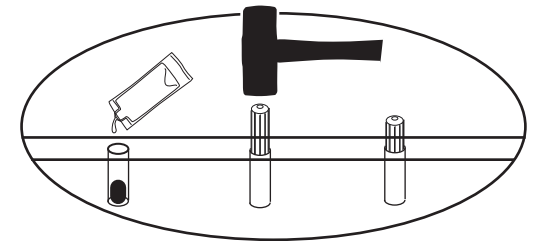

1. Instill the glue (Ww) to the wood dowel hole as image shown.
2. Insert the wood dowel (V) to the part (H).
3. Attached the cam bolt (W) to part (H).
4. Attach the metal slide (Ff) to the part (H) with screw (Gg).

step 9.

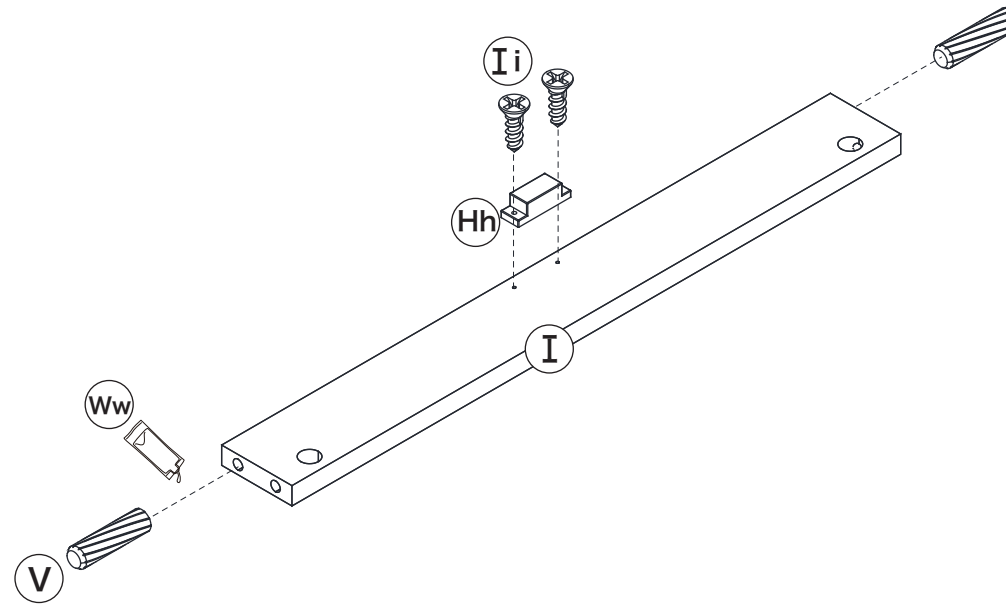

(V) x 2
Wood dowel
Ø7.8 X 30mm

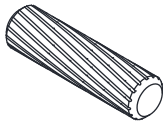

(Hh) x 1
Magnet

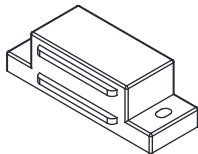

(Ii) x 2
Screw Ø3 X 16mm

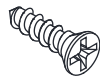

(Ww)
Glue

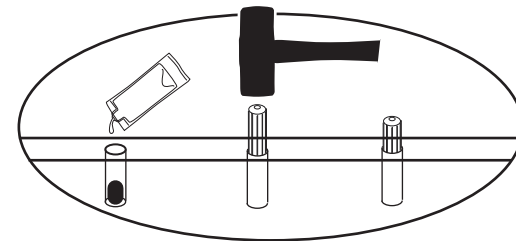

1. Instill the glue (Ww) to the wood dowel hole as image shown.
2. Insert the wood dowel (V) to the part (I).
3. Attach the magnet (Hh) to the part (I) with screw (Ii), please pay attention and make sure the side of the magnet is correct.

step 10.

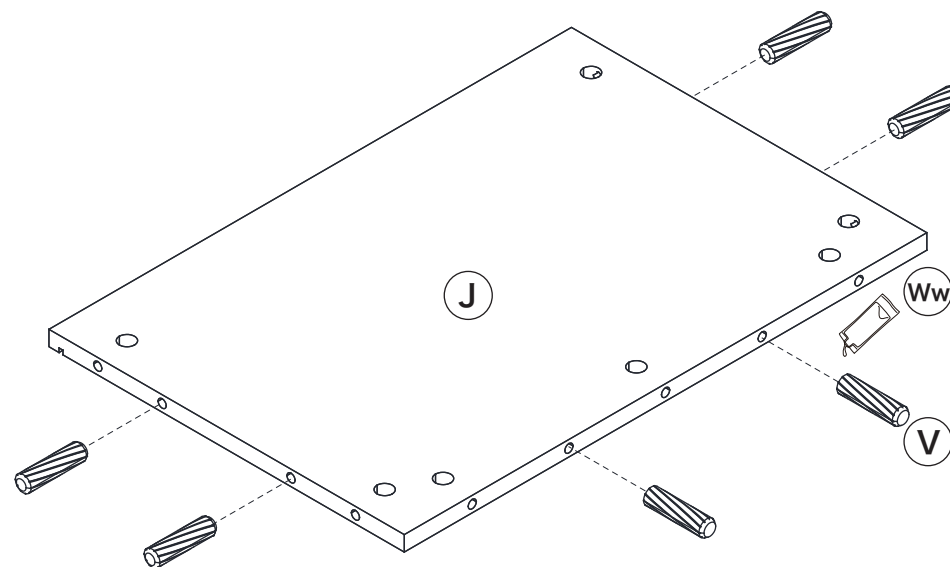

(V) x 6
Wood dowel
Ø7.8 X 30mm

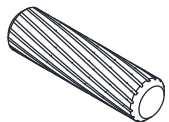

(Ww)
Glue

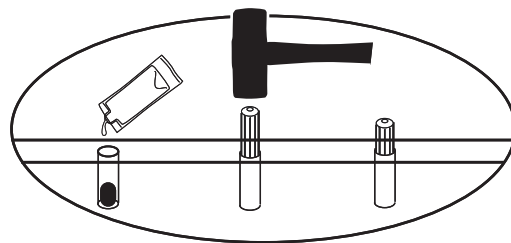

1. Instill the glue (Ww) to the wood dowel hole as image shown.
2. Insert the wood dowel (V) to the part (J).

step 11.

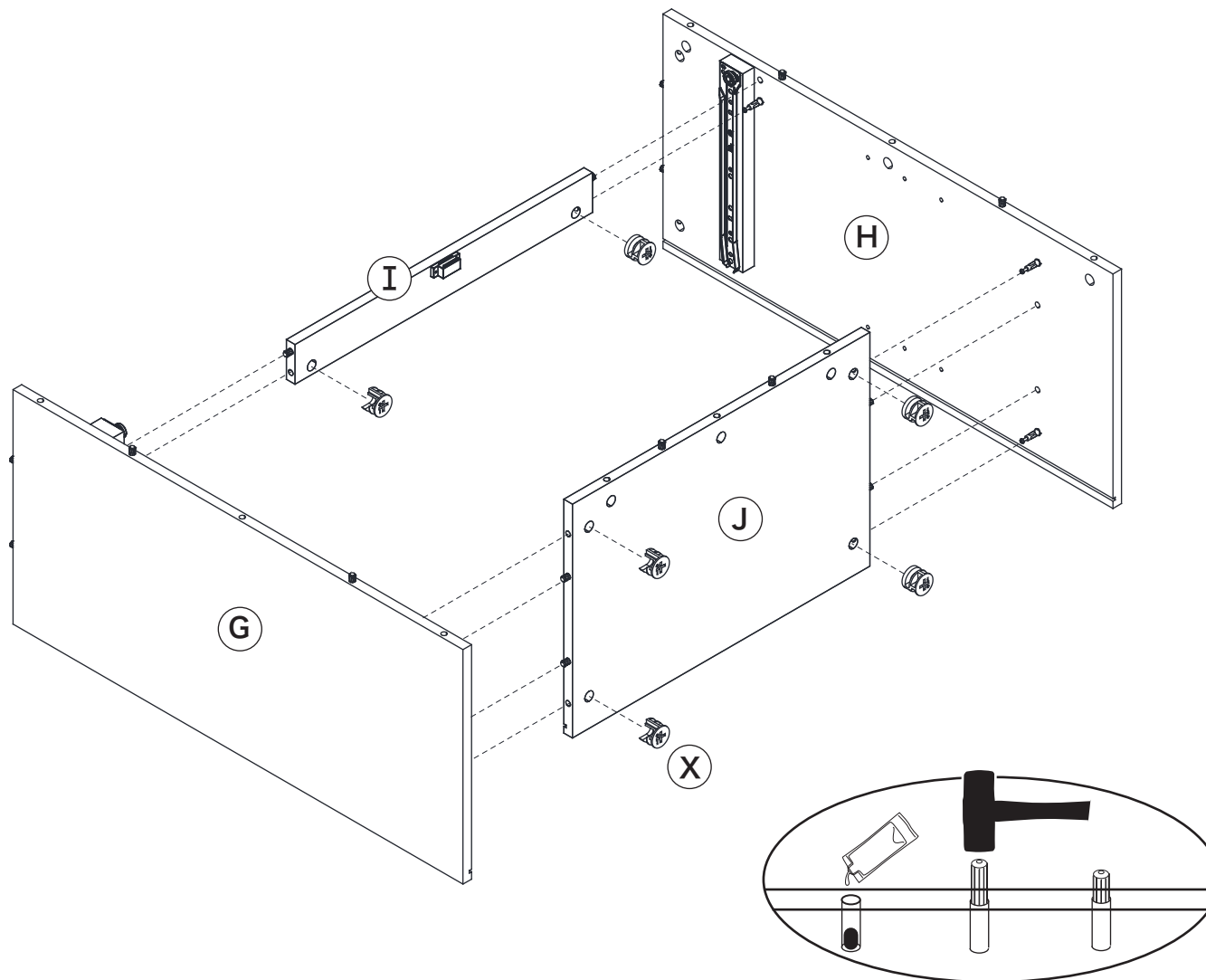

(X) x 6
Cam

(Ww)
Glue



1. Instill the glue (Ww) to the wood dowel hole as image shown.
2. Attach part (I) and (J) to the part (G) and (H) .
3. Tighten all the parts with cam (X).

step 12.

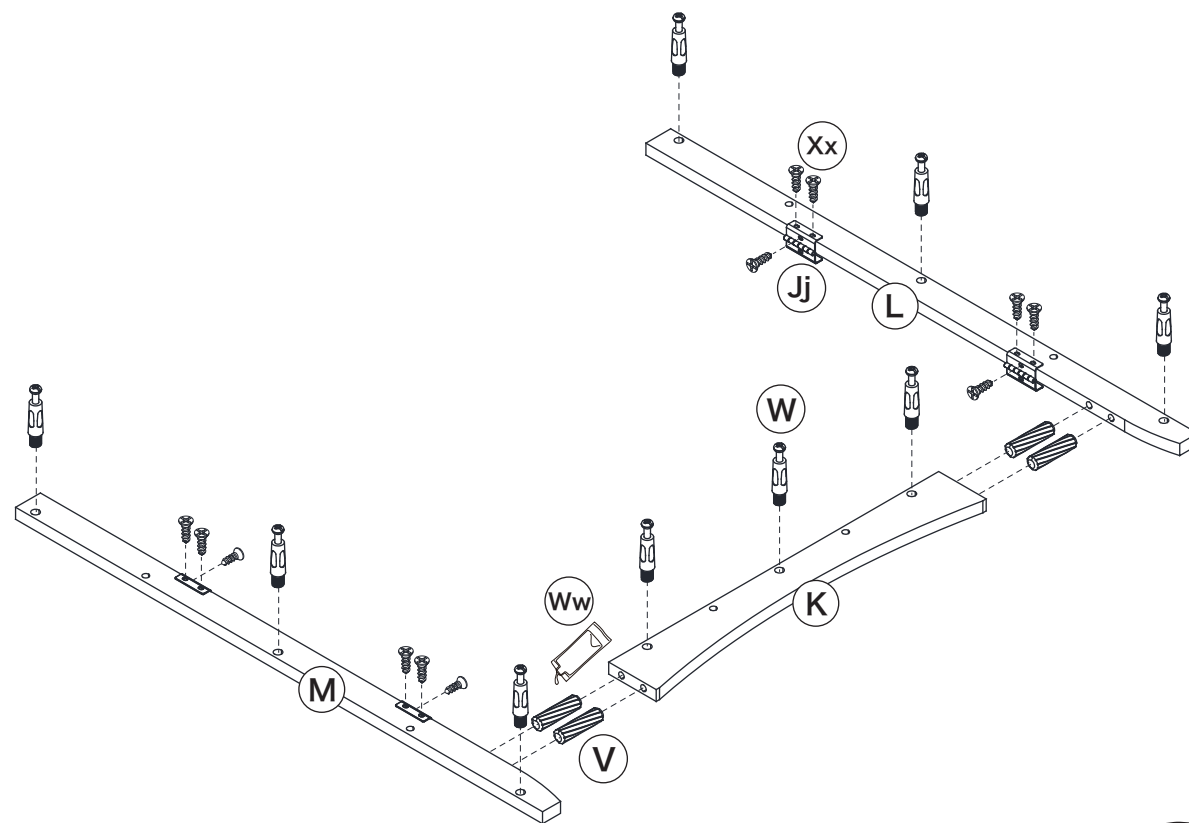

(V) x 4
Wood dowel
Ø7.8 X 30mm

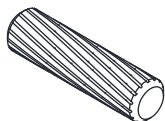

(W) x 9
Cam bolt



(Jj) x 4
Hinge

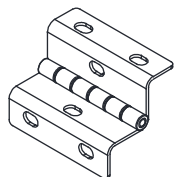

(Xx) x 12
Screw Ø3 X 12mm



(Ww)
Glue

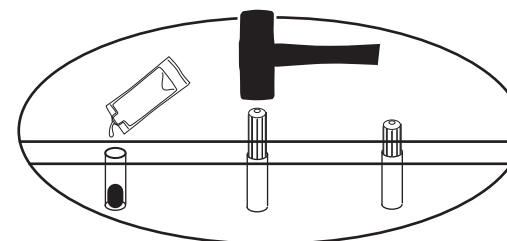

1. Attach the hinge (Jj) to the part (L) and (M) with screw (Xx).
2. Insert the cam bolt (W) to parts (K), (L) and (M).
3. Instill the glue (Ww) to the wood dowel hole as image shown.
4. Attach the wood dowel (V) to part (K).
5. Attach all the parts (K), (L) and (M) together as image shown.

step 13.

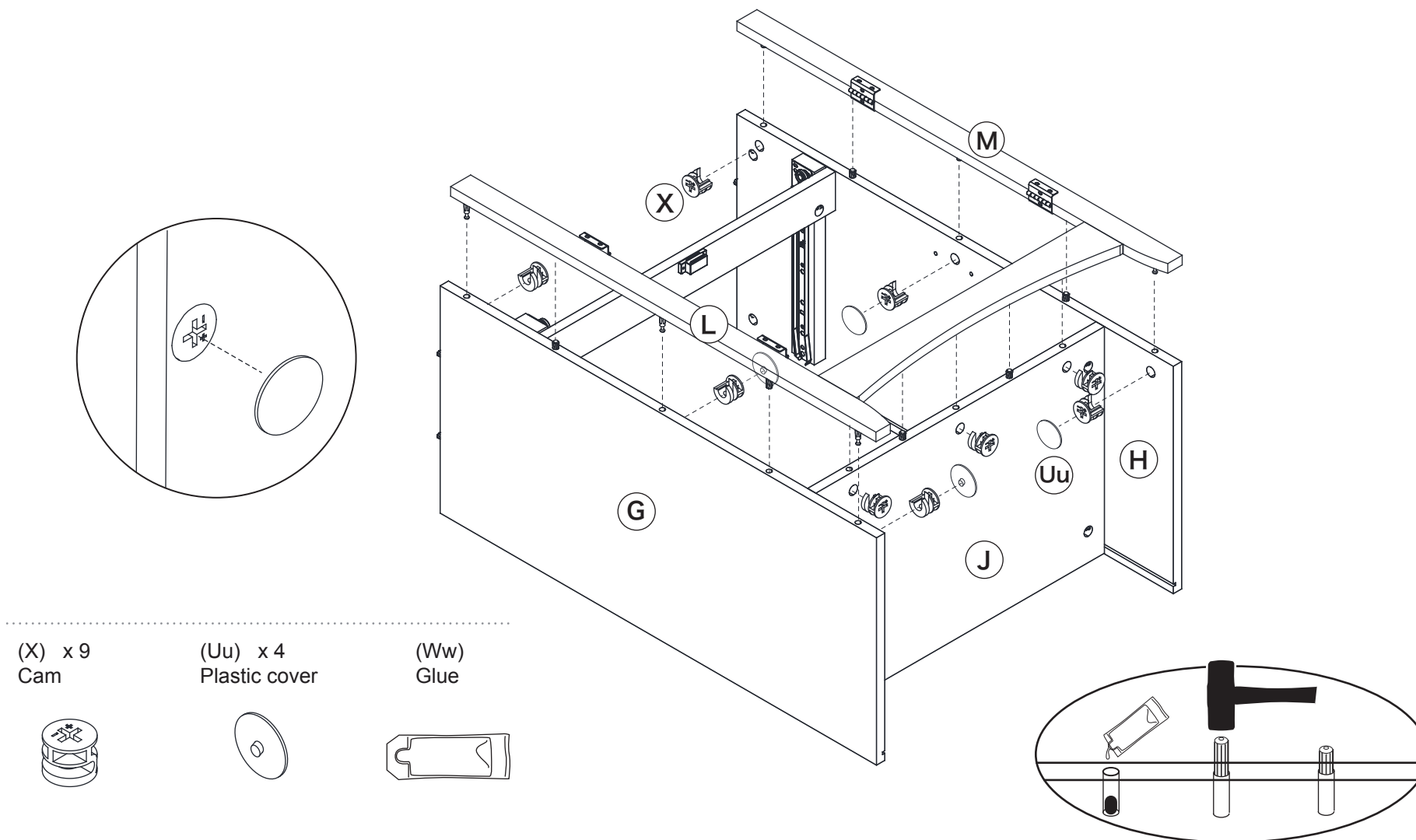

1. Instill the glue (Ww) to the wood dowel hole as image shown.
2. Attach the parts (K), (L) and (M) together with parts (G), (H) and (J) as image shown.
3. Tighten all the parts with cam (X).
4. Cover the cam holes using plastic cover (Uu).

step 14.

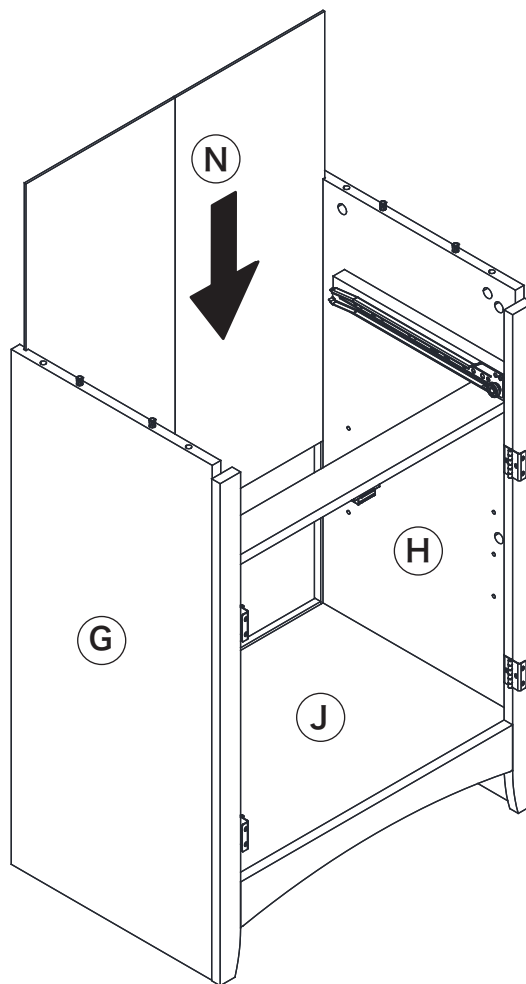

1. Insert the back panel (N) to the groove of parts (G), (H) and (J).

step 15.

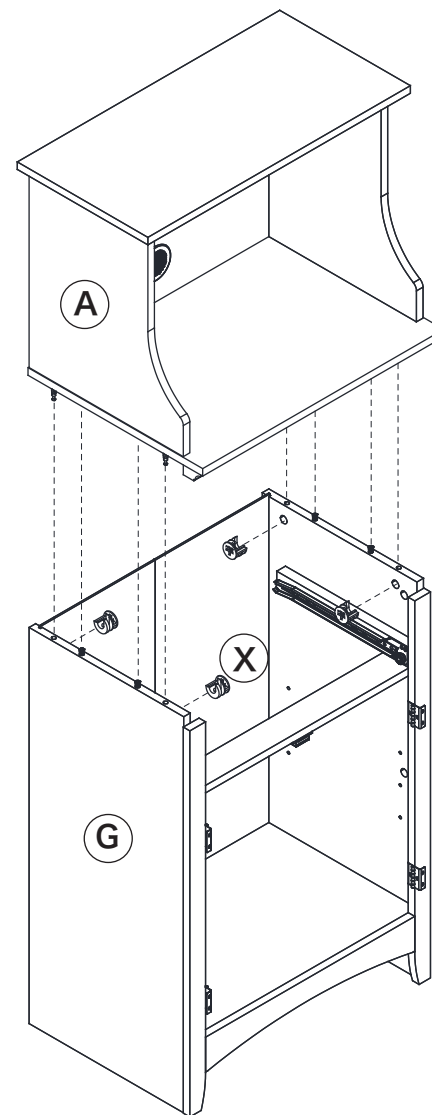
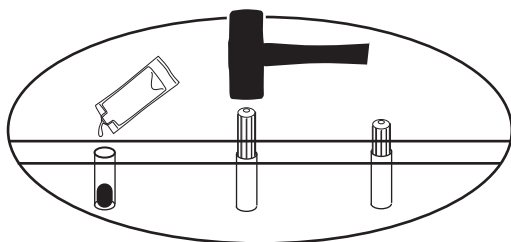

(X) x 4
Cam



(Ww)
Glue



1. Instill the glue (Ww) to the wood dowel hole as image shown.
2. Attach the parts which has assembled in step 6 to the parts which has assembled in step 14, to make sure the back panel (N) is inserted in the groove of part (E) properly.
3. Tighten all the parts with cam (X).

step 16.

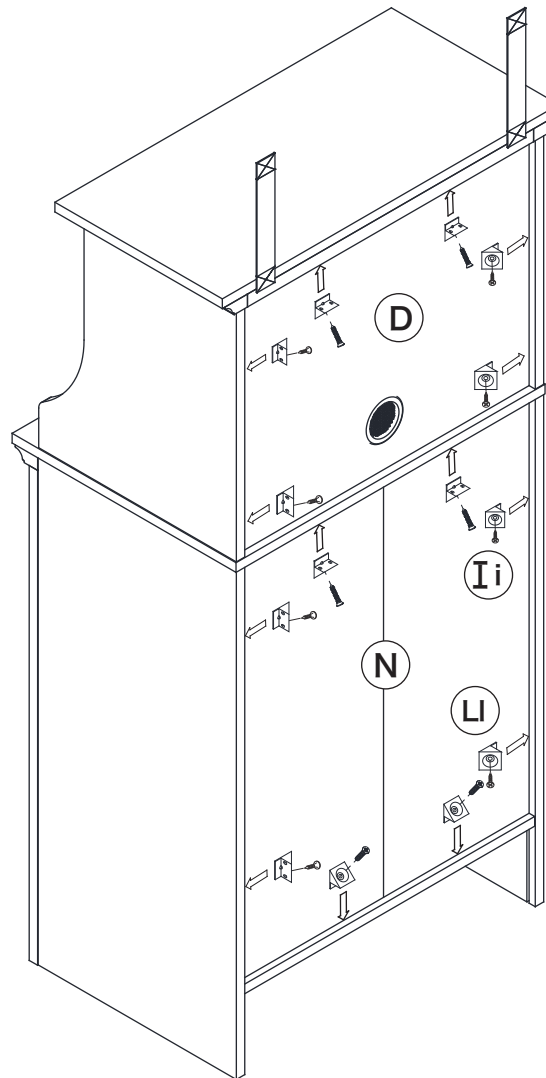

(Ii) x 14
Screw Ø3 X 16mm

(LI) x 14
Plastic connector

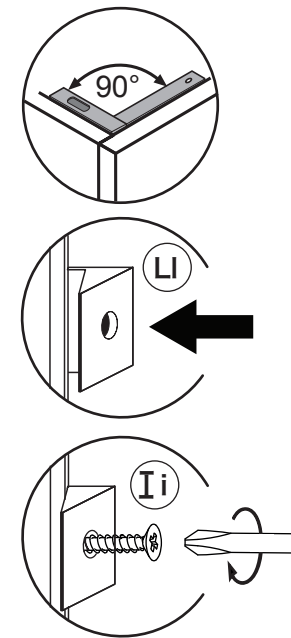
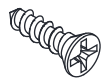

1. Attach the plastic connector (LI) to the product with screw (Ii).

step 17.

x 2

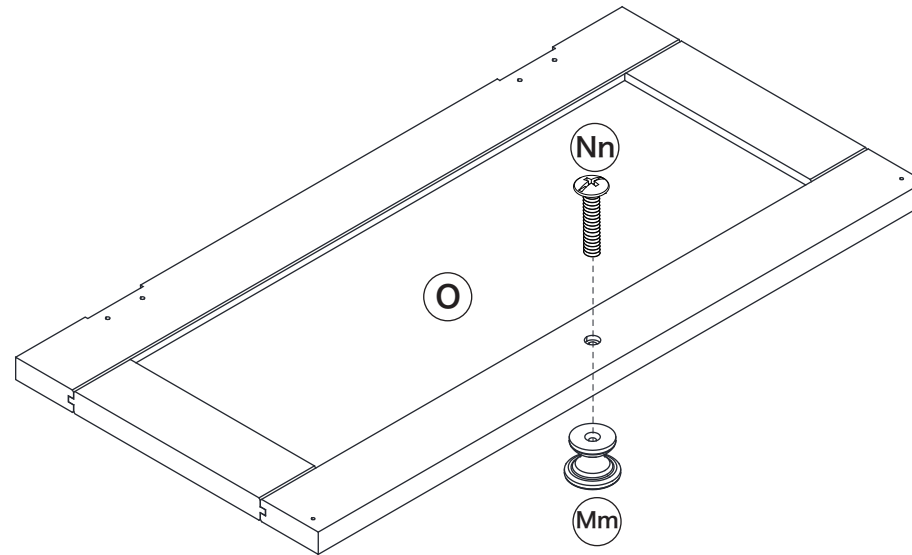

(Mm) x 2
Handle

(Nn) x 2

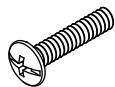

1. Attach the handle (Mm) to the part (O) using screw (Nn).
2. Do this step in twice.

step 18.

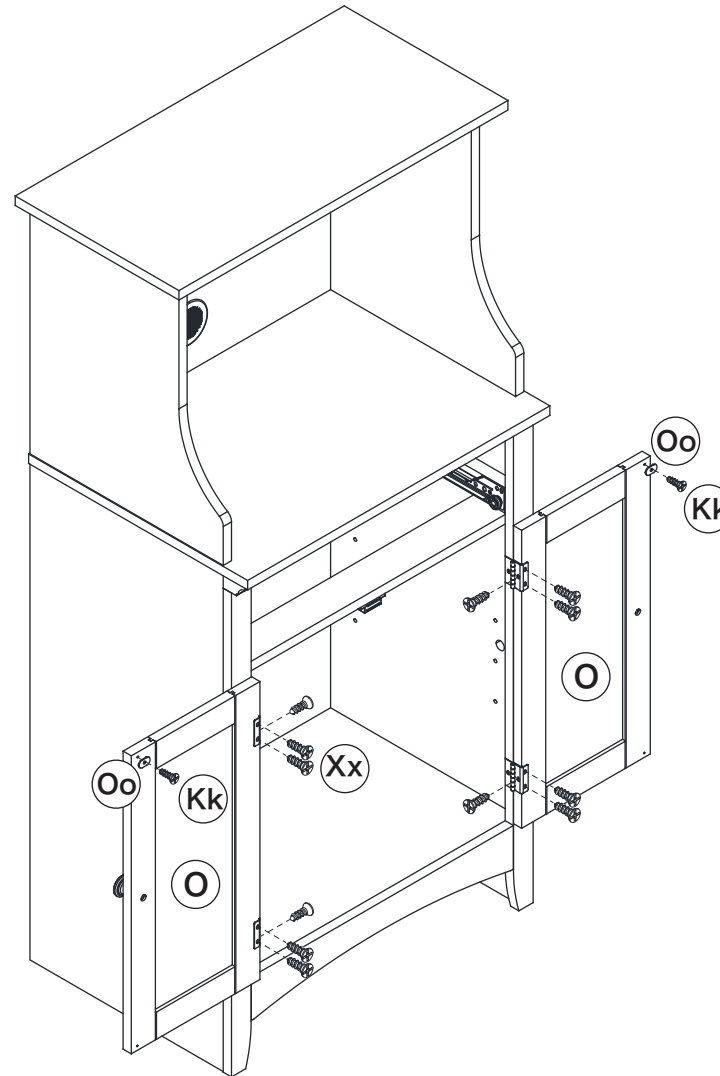
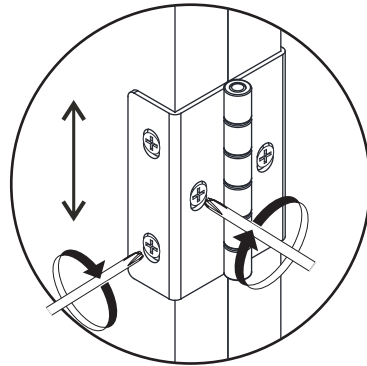

(Xx) x 12
Screw Ø3.5 X 12mm

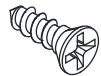

(Kk) x 2
Screw Ø3 X 12mm



(Oo) x 2
Metal plate



1. Attach the part (O) to the body using the hinge (Jj) and screw (Xx).
2. Attach the metal plate (Oo) to the part (O) with screw (Kk).
3. You could make adjustment on the hinge if you found any gap difference on the door as image shown.

step 19.

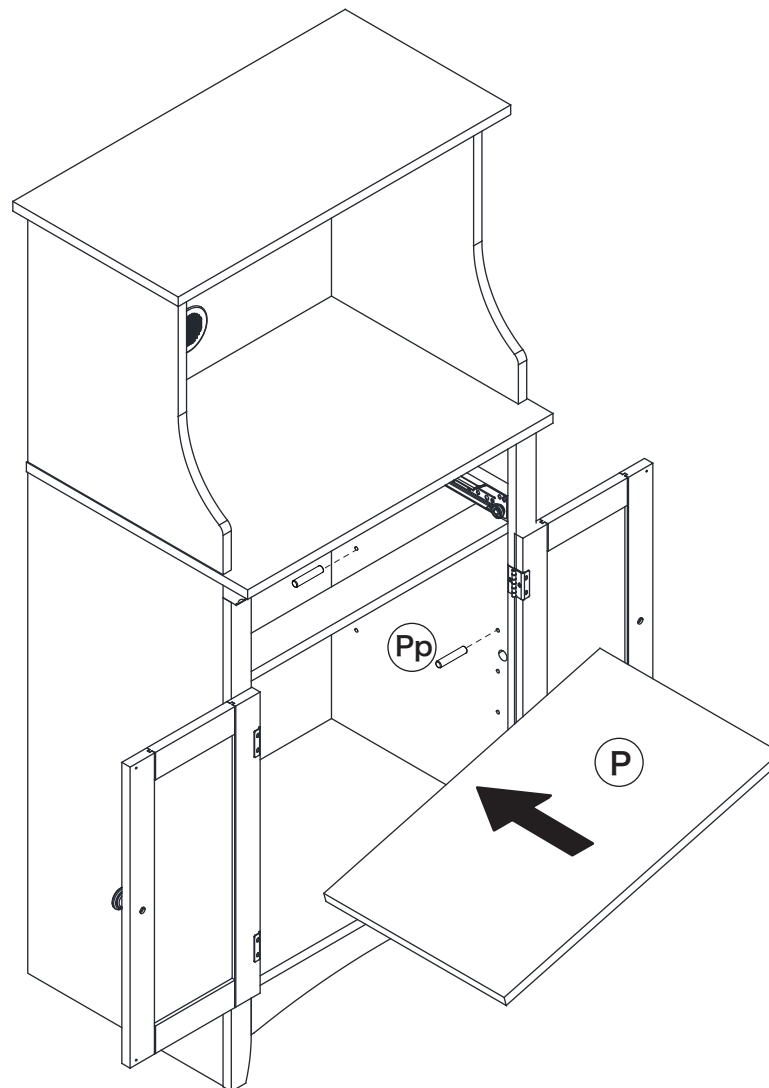

(Pp) x 4
Shelf pin

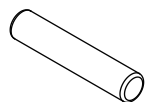

1. Insert the shelf pin (Pp) to parts (G) and (H).
2. Put the shelf (P) into the product as image shown.

step 20.

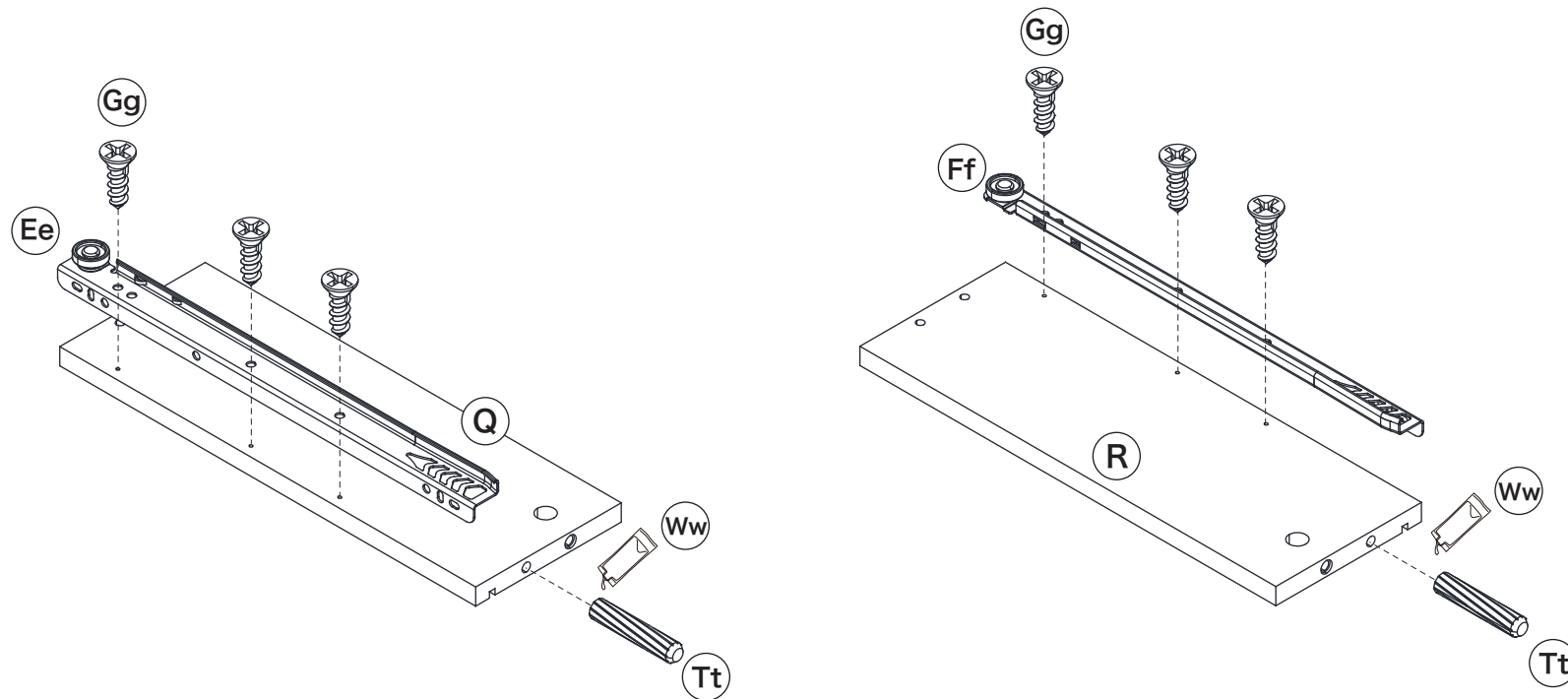

(Ee) x 1
Metal slide (left)

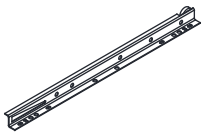

(Ff) x 1
Metal slide (right)

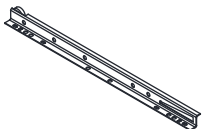

(Gg) x 6
Screw Ø3.5 X 12mm

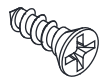

(Tt) x 2
Wood dowel
Ø5.8 X 30mm

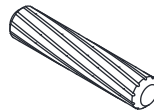

(Ww)
Glue

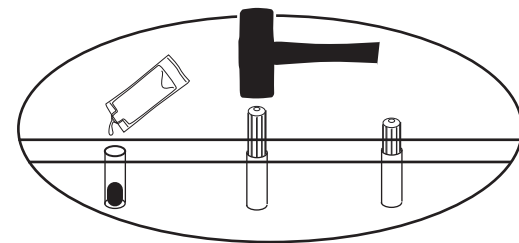

1. Attach the metal slide (Ee) to the part (Q) with screw (Gg).
2. Attach the metal slide (Ff) to the part (R) with screw (Gg).
3. Instill the glue (Ww) to the wood dowel hole as image shown.
4. Insert the wood dowel (Tt) to the part (Ee) and (Ff).

step 21.

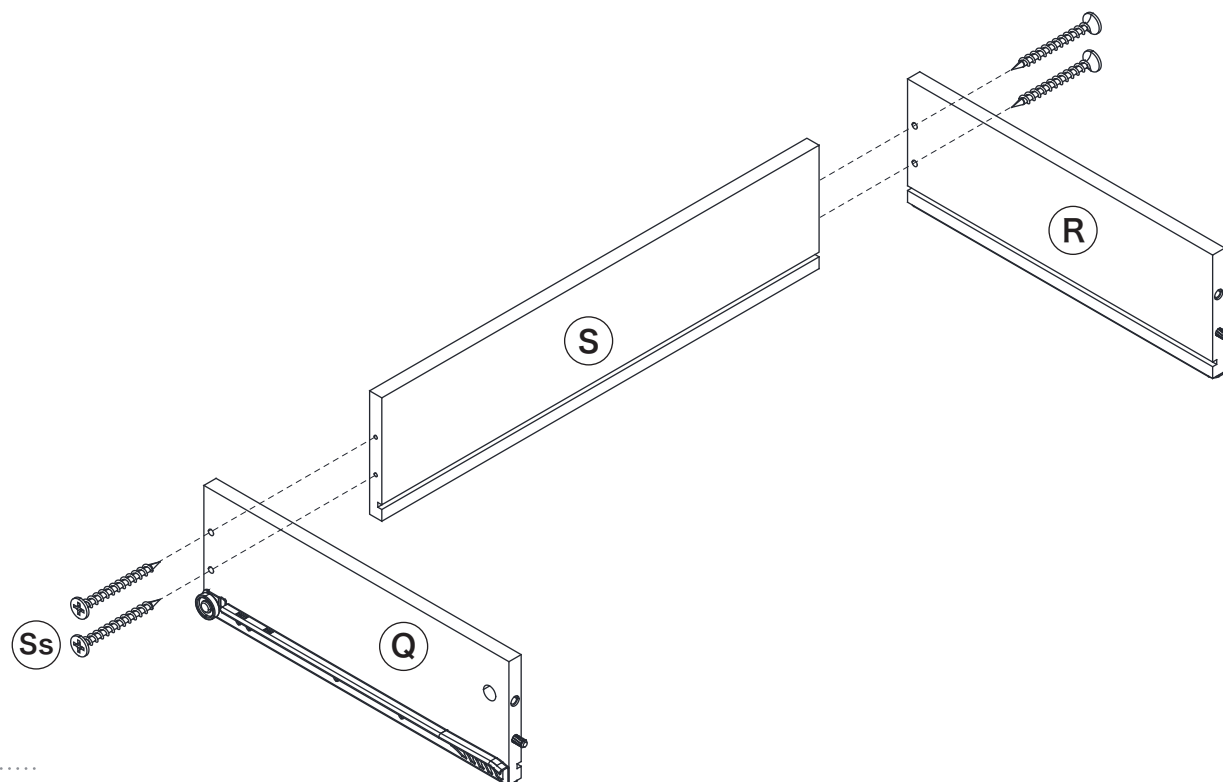

(Ss) x 4
Screw Ø3.8 X 35mm

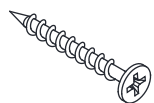

1. Attach the three parts (Q), (R) and (S) together with screw (Ss).

step 22.

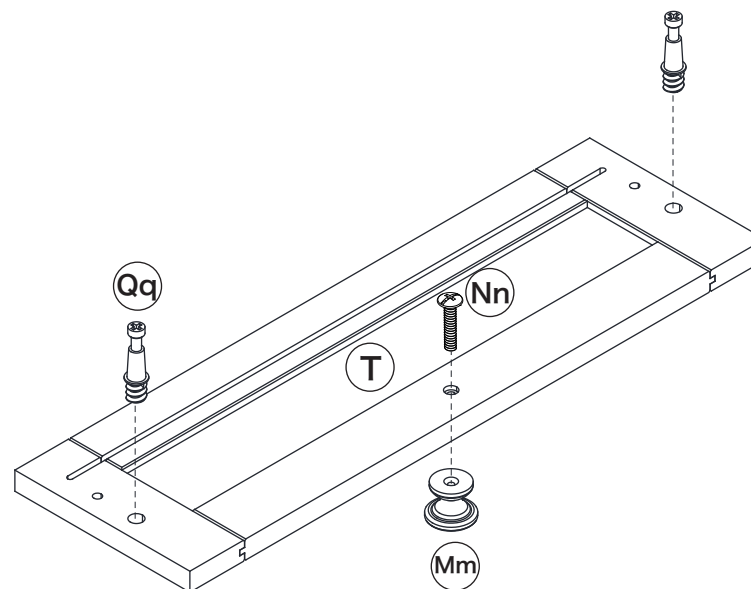

(Mm) x 1
Handle

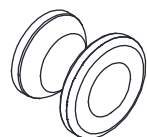

(Nn) x 1
Screw M4 x 20mm



(Qq) x 2
Cam bolt

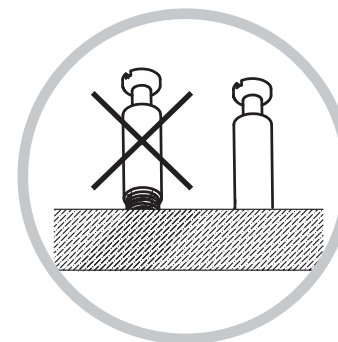

1. Insert the cam bolt (Qq) to the part (T).
2. Attach the handle (Mm) to the part (T) with screw (Nn).

step 23.

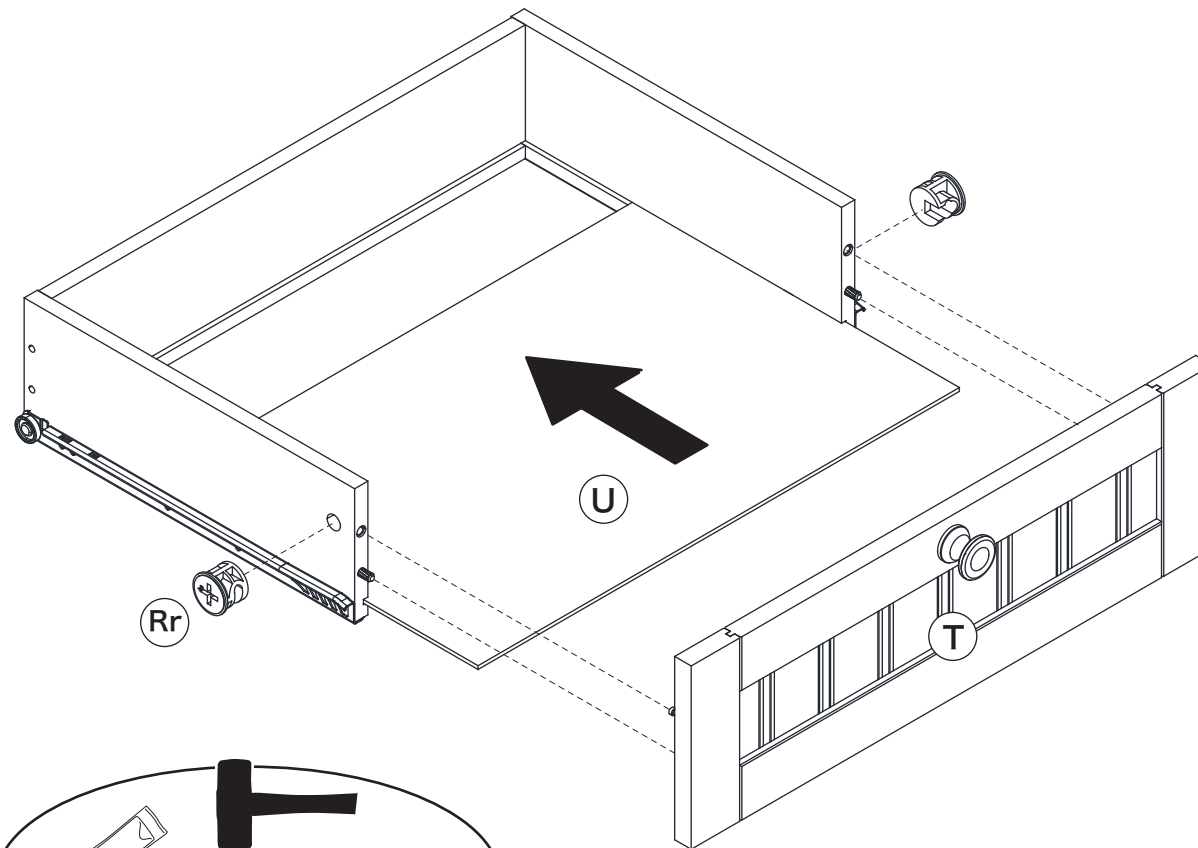

(Rr) x 2
Cam



(Ww)
Glue

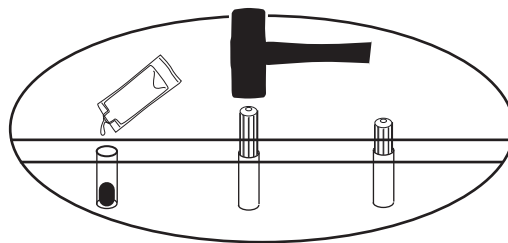

1. Insert the drawer bottom (U) to the groove of parts (Q), (R) and (S).
2. Instill the glue (Ww) to the wood dowel hole as image shown.
3. Attach the drawer face (T) with the parts as image shown, to make sure drawer bottom (U) is inserted in the groove of drawer face (T) properly.
4. Tighten all parts with cam (Rr).

step 24.

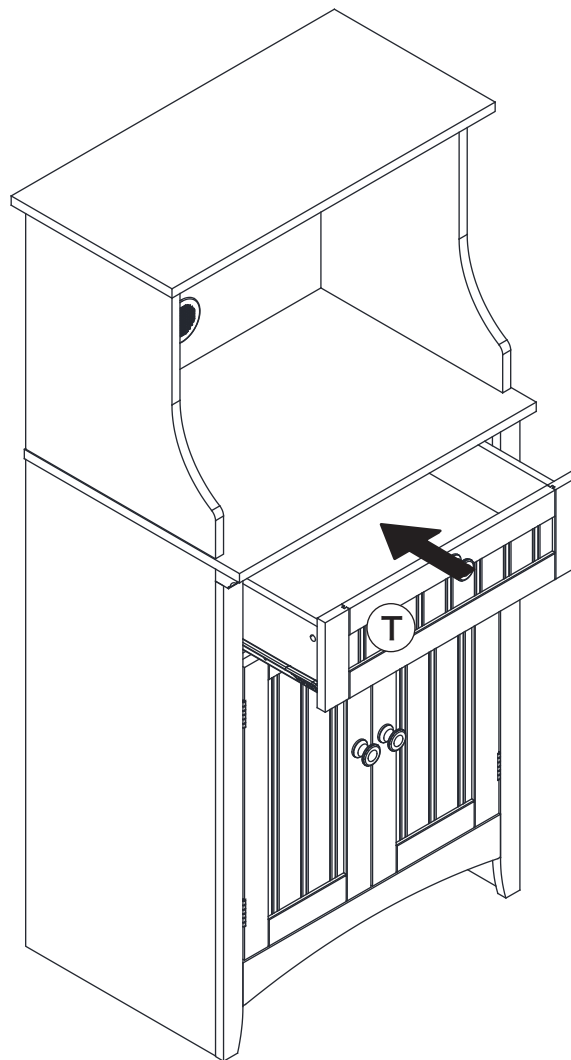
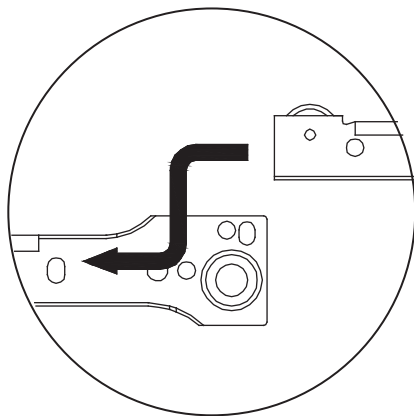

1. Install the drawer into the product as image shown.

step 25.

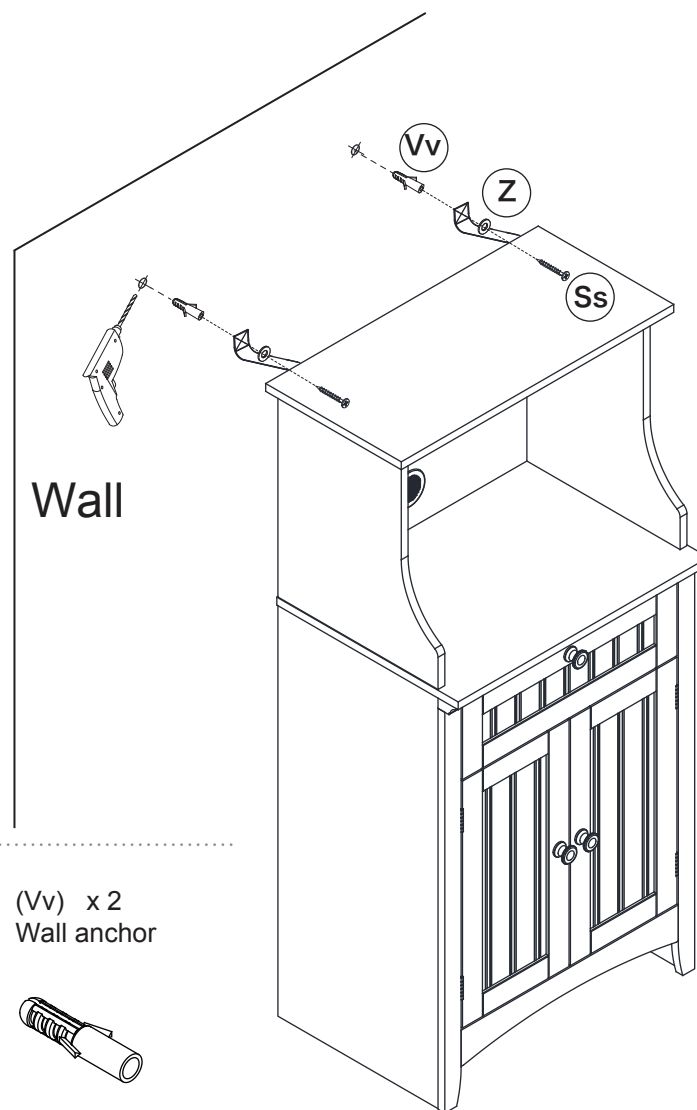

(Z) x 2
Metal washer



(Ss) x 2
Screw Ø3.8 X 35mm

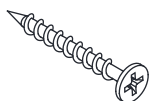

(Vv) x 2
Wall anchor



1. Drilling the hole in the wall using drill Ø6, for better looking, please drill the hole a little lower than the product.
2. Knock the wall anchor (Vv) into the hole.
3. Attach the fabric strap (Y) to the wall anchor using metal washer (Z) and screw (Ss).