

# ASSEMBLY INSTRUCTIONS



*Fine Furniture for every stage of life*

**Full Bed**

# ASSEMBLY INSTRUCTIONS

## ASSEMBLY TIPS:

1. Remove hardware from box and sort by size.
2. Please check to see that all hardware and parts are present prior to start of assembly.
3. Please follow attached instructions in the same sequence as numbered to assure fast & easy assembly.



### WARNING!

1. Don't attempt to repair or modify parts that are broken or defective. Please contact the store immediately.
2. This product is for home use only and not intended for commercial establishments.













ASSEMBLY TIME

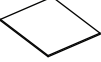



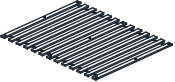
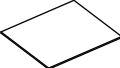

30 MINUTES

## PARTS IDENTIFICATION

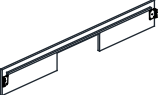
### B1 (BOX 1)

A	HAEDBOARD PANEL		1PC	H	BED RAIL DRAWER SUPPORT		4PCS
B	LEFT HEADBOAD LEG (WITH "L" LABEL)		1PC	I	FOOTBOARD DRAWER BACK PANEL (WITH "I" LABEL)		2PCS
C	RIGHT HEADBOARD LEG (WITH "R" LABEL)		1PC	J	FOOTBOARD DRAWER BOTTOM PANEL		2PCS
D	BED RAIL DRAWER BACK PANEL (WITH "D" LABEL)		2PCS	K	FOOTBOARD DRAWER SUPPORT		4PCS
E	DRAWER LEFT SIDE PANEL (WITH "E" LABEL)		4PCS	L	CASTER WITH SCREW		16SETS
F	DRAWER RIGHT SIDE PANEL (WITH "F" LABEL)		4PCS	M	ROLL SLAT (13pcs)		1SET
G	BED RAIL DRAWER BOTTOM PANEL		2PCS				

### B2 (BOX 2)

N	BED RAIL DRAWER FRONT PANEL		2PCS	R	BED RAIL		2PCS
O	FOOTBOARD DRAWER FRONT PANEL		2PCS	S	BED RAIL SUPPORT LEG		4PCS
P	FOOTBOARD FRAME		1PC	T	CENTER RAIL		1PC
Q	FOOTBOARD LEG		2PCS	U	CENTER RAIL SUPPORT WITH LEVELER		3PCS

### NOTE:

Phillips head screw driver is required in the assembly process; however, manufacturer does not provided this item.

### ASSEMBLY TIPS:

1. Remove hardware from box and sort by size.
2. Please check to see that all hardware and parts are present prior to start of assembly.
3. Please follow attached instructions in the same sequence as numbered to assure fast & easy assembly.







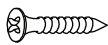

### WARNING!

1. Don't attempt to repair or modify parts that are broken or defective. Please contact the store immediately.
2. This product is for home use only and not intended for commercial establishments.

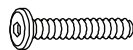
## HARDWARE IDENTIFICATION

### BOX 2 - HARDWARE PACK

1	<b>SHORT BOLT</b> (M8 x 20MM - RBW)		8PCS	6	<b>FLAT HEAD SCREW</b> (M4 x 32MM - RBW)		38PCS
2	<b>MEDIUM BOLT</b> (M6 x 35MM - RBW)		16PCS	7	<b>WOOD DOWEL</b> (M8 x 30MM)		64PCS
3	<b>LONG BOLT</b> (M6 x 50MM - RBW)		11PCS	8	<b>SMALL ALLEN WRENCH</b> (M4 x 65MM - BLK)		1PC
4	<b>LOCK WASHER</b> (15/64" X 13 Ø - RBW)		14PCS	9	<b>BIG ALLEN WRENCH</b> (M5 x 65MM - BLK)		1PC
5	<b>FLAT WASHER</b> (15/64" X 19 Ø - RBW)		14PCS				

### NOTE:

Phillips head screw driver is required in the assembly process; however, manufacturer does not provided this item.

# ASSEMBLY INSTRUCTIONS

## STEP 1

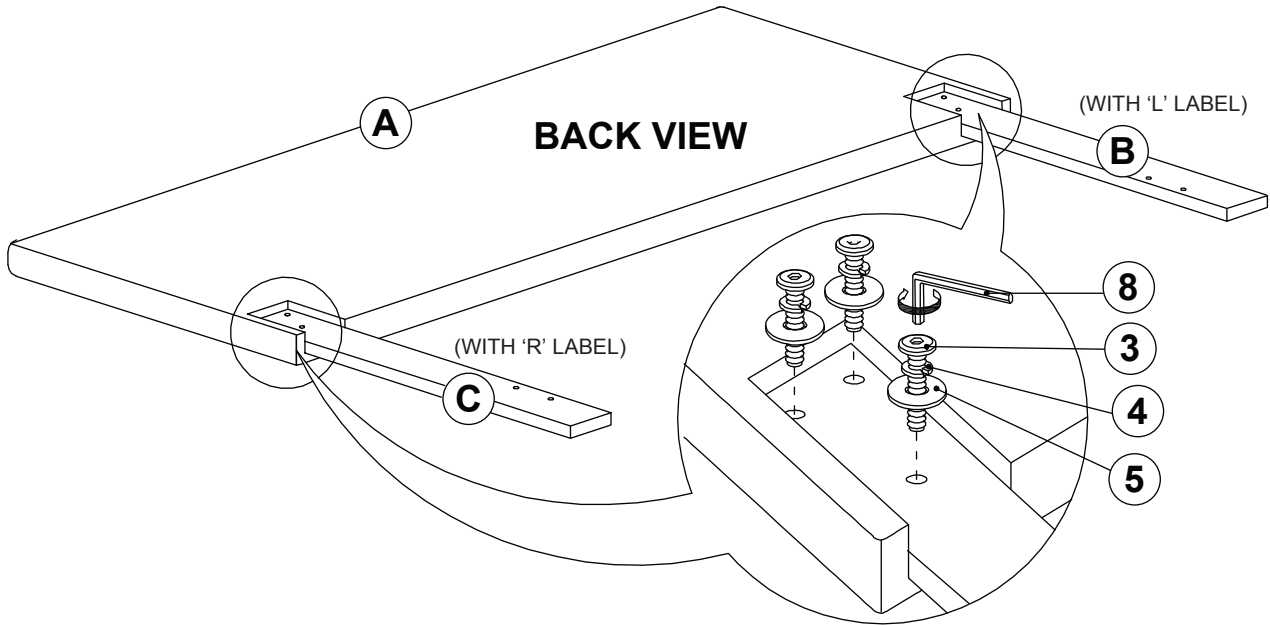

## STEP 2

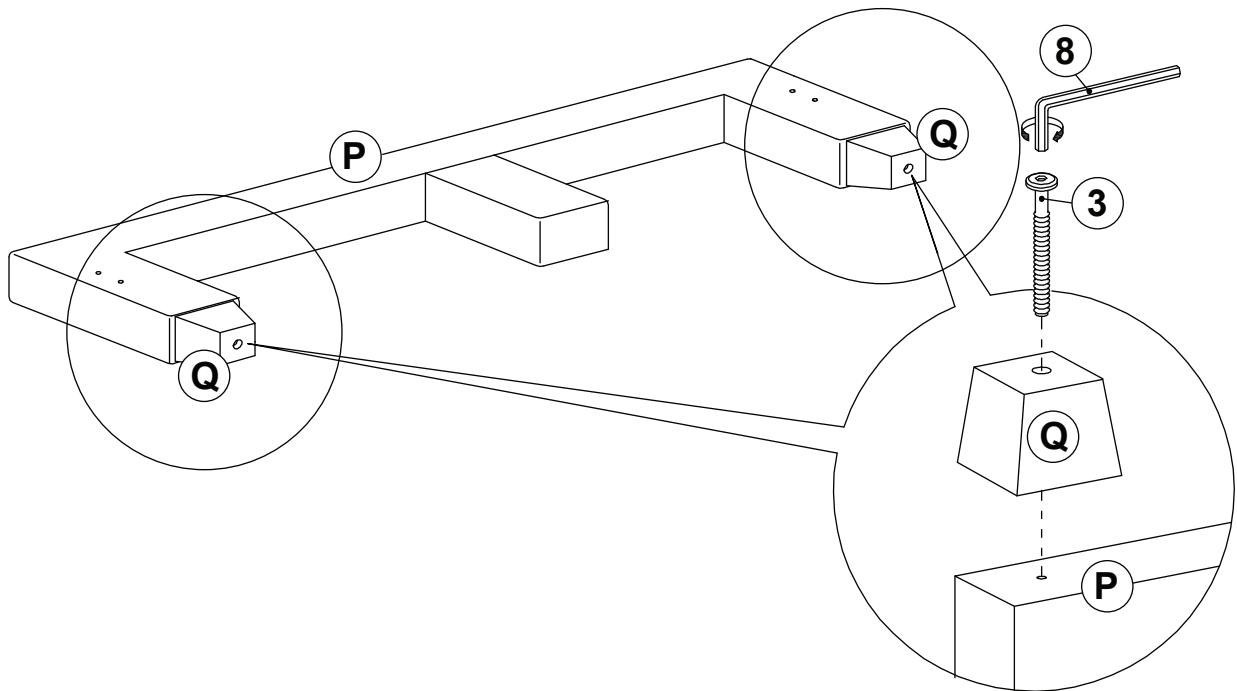

# ASSEMBLY INSTRUCTIONS

## STEP 3

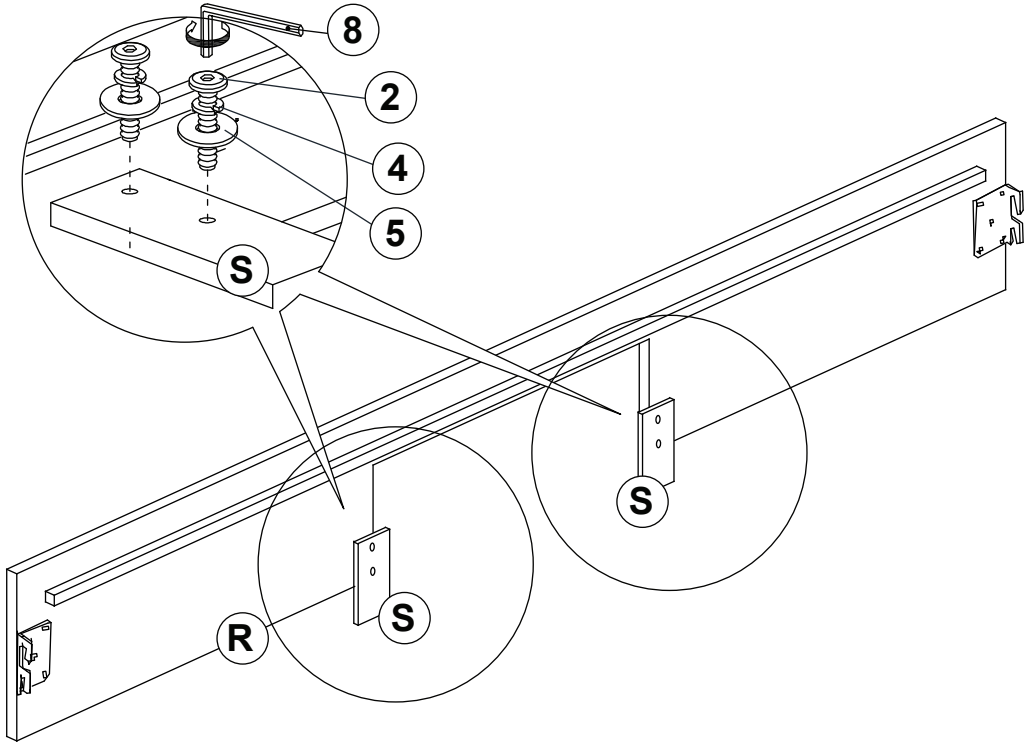

## STEP 4

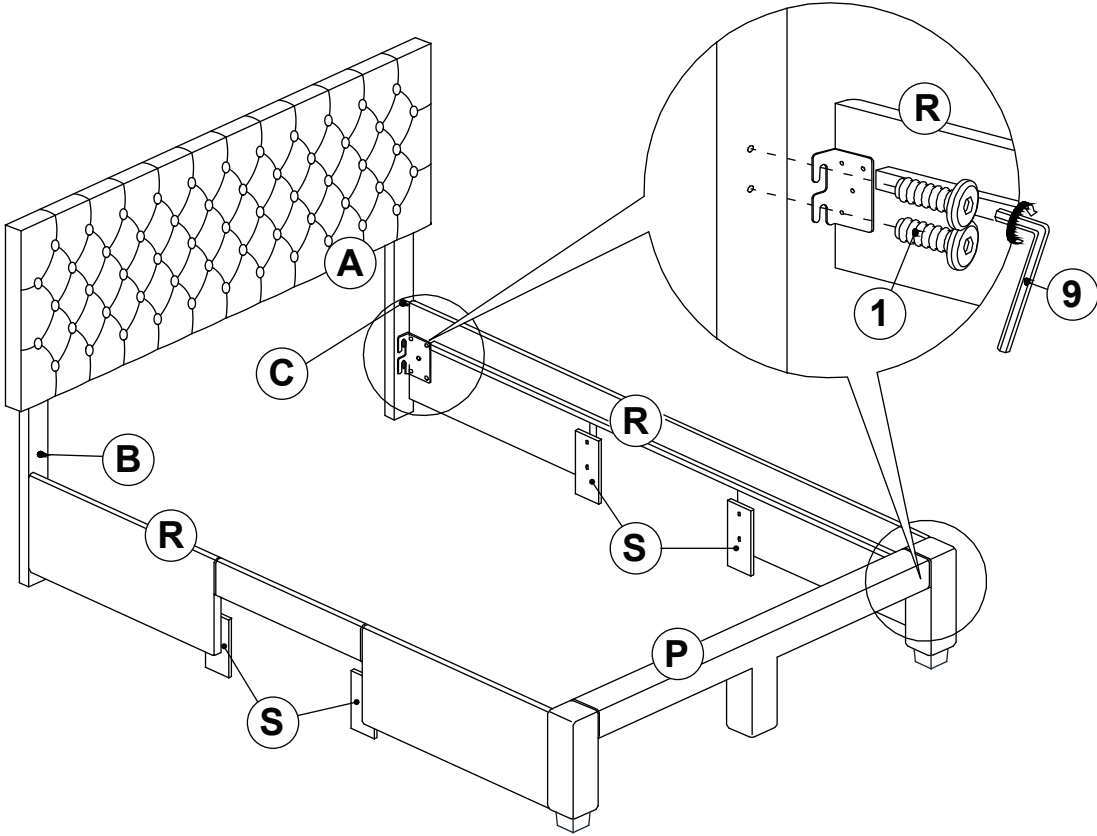

# ASSEMBLY INSTRUCTIONS

## STEP 5

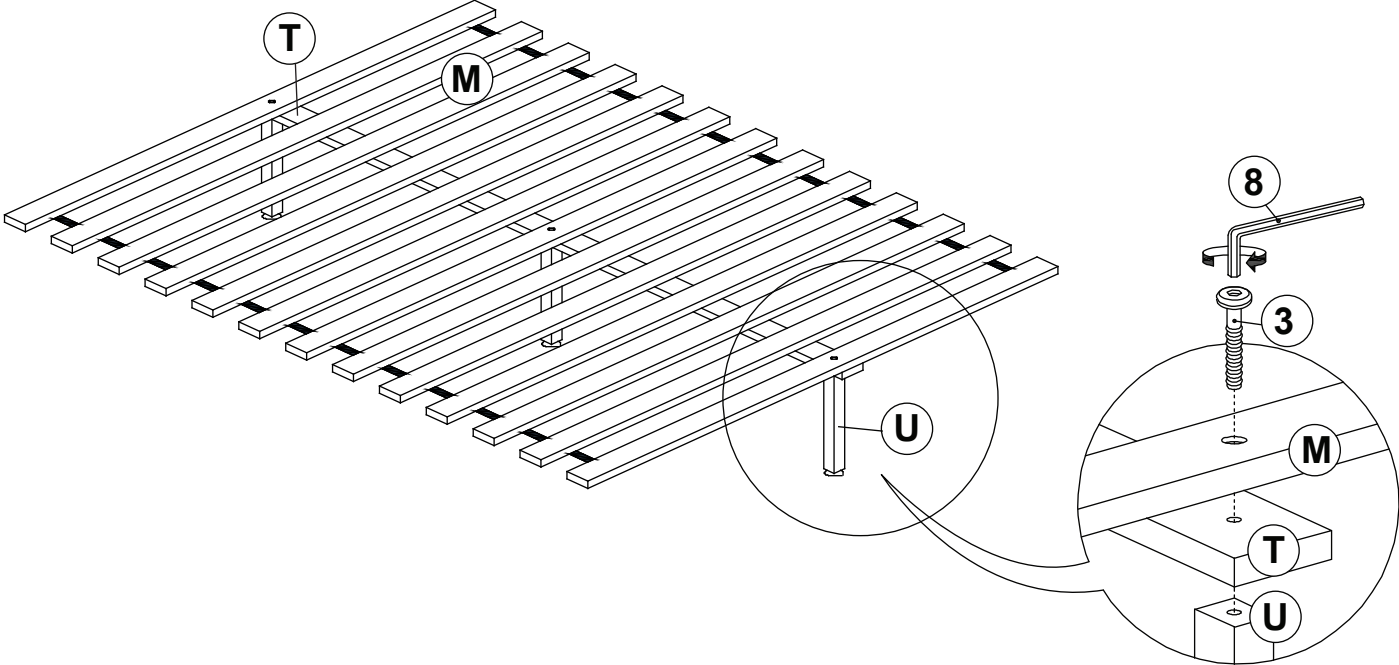

## STEP 6

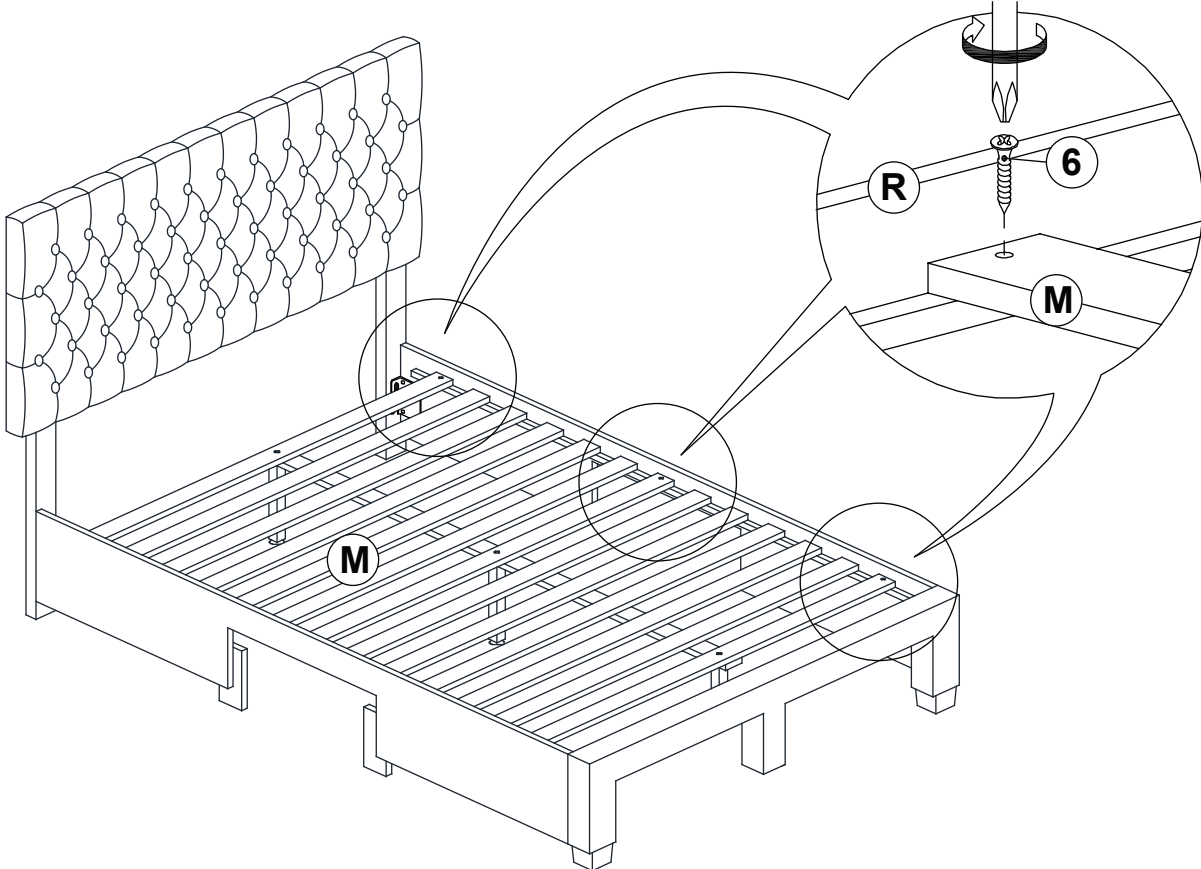

# ASSEMBLY INSTRUCTIONS

## STEP 7

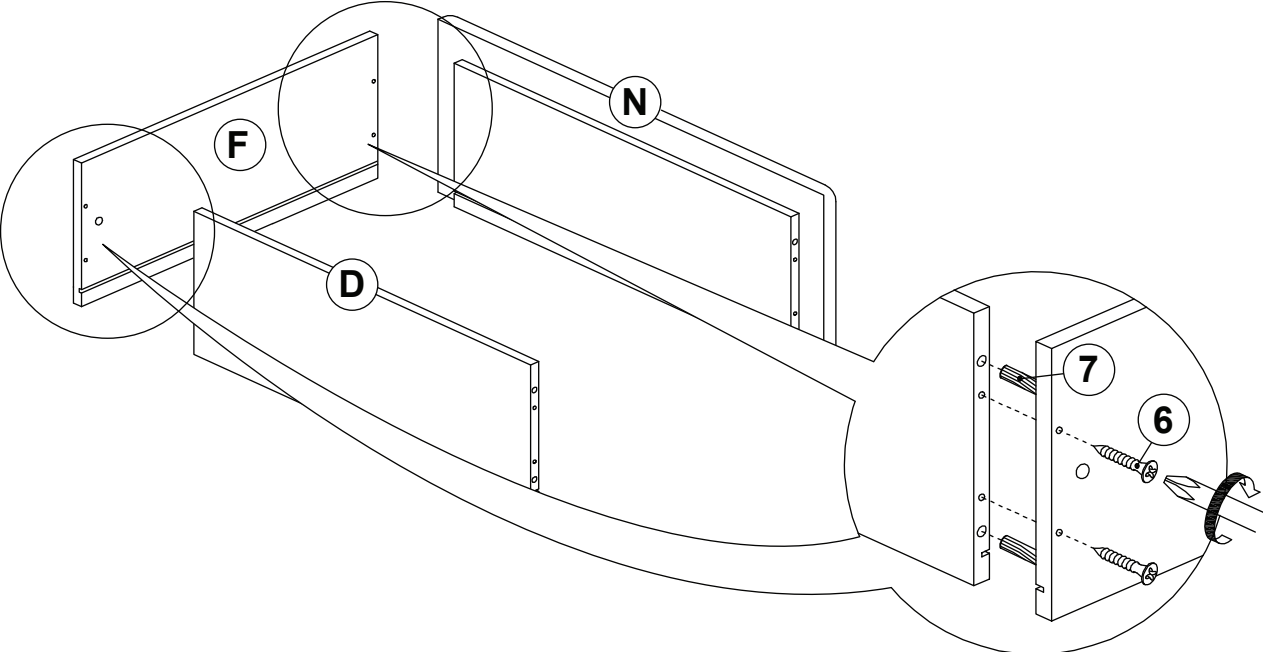

## STEP 8

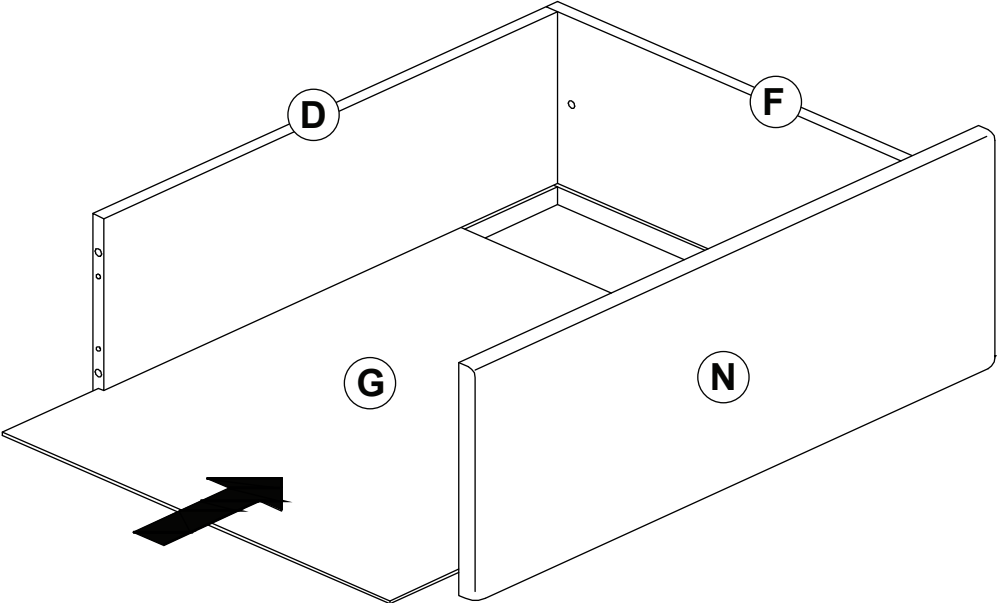

# ASSEMBLY INSTRUCTIONS

## STEP 9

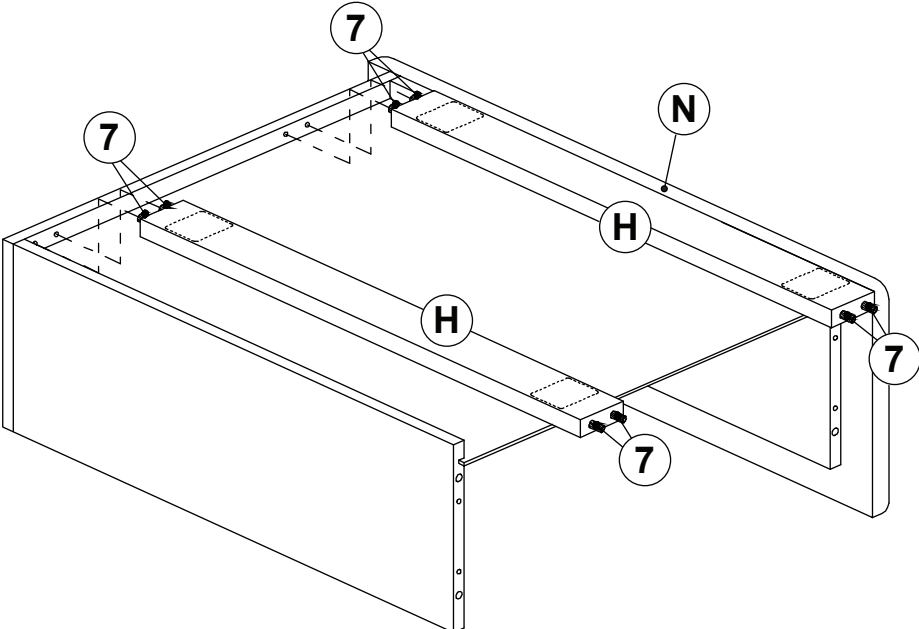

## STEP 10

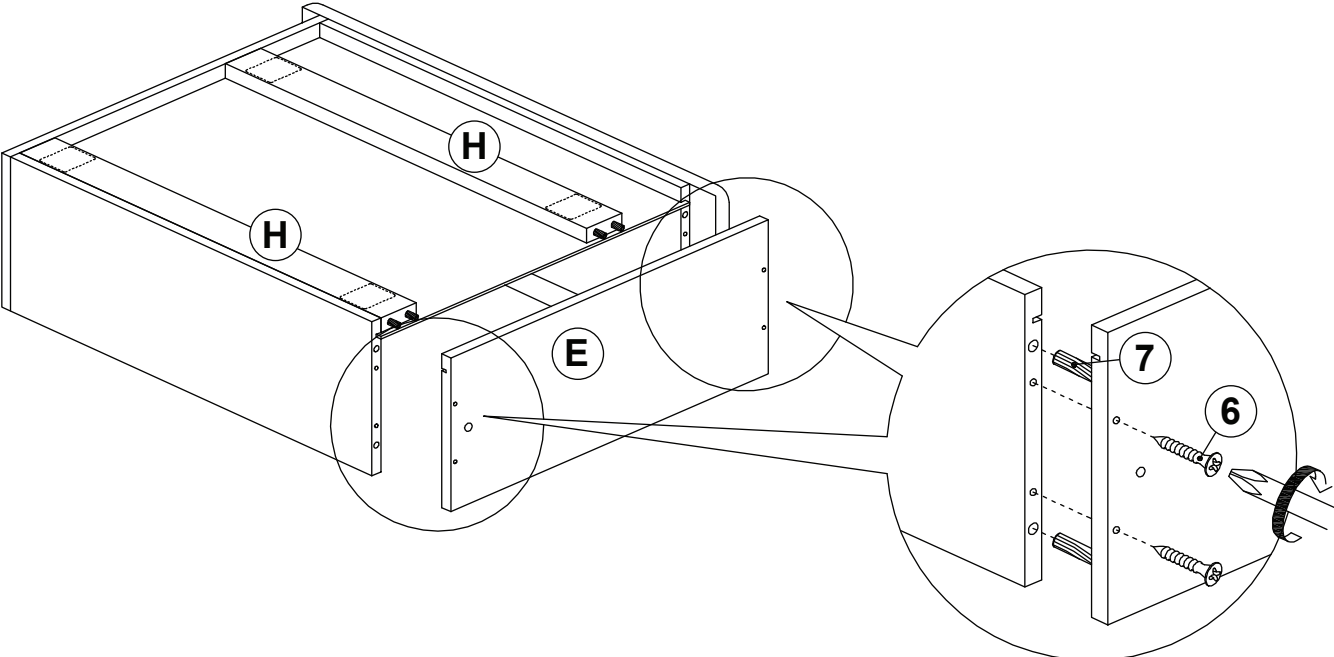



# ASSEMBLY INSTRUCTIONS

## STEP 11

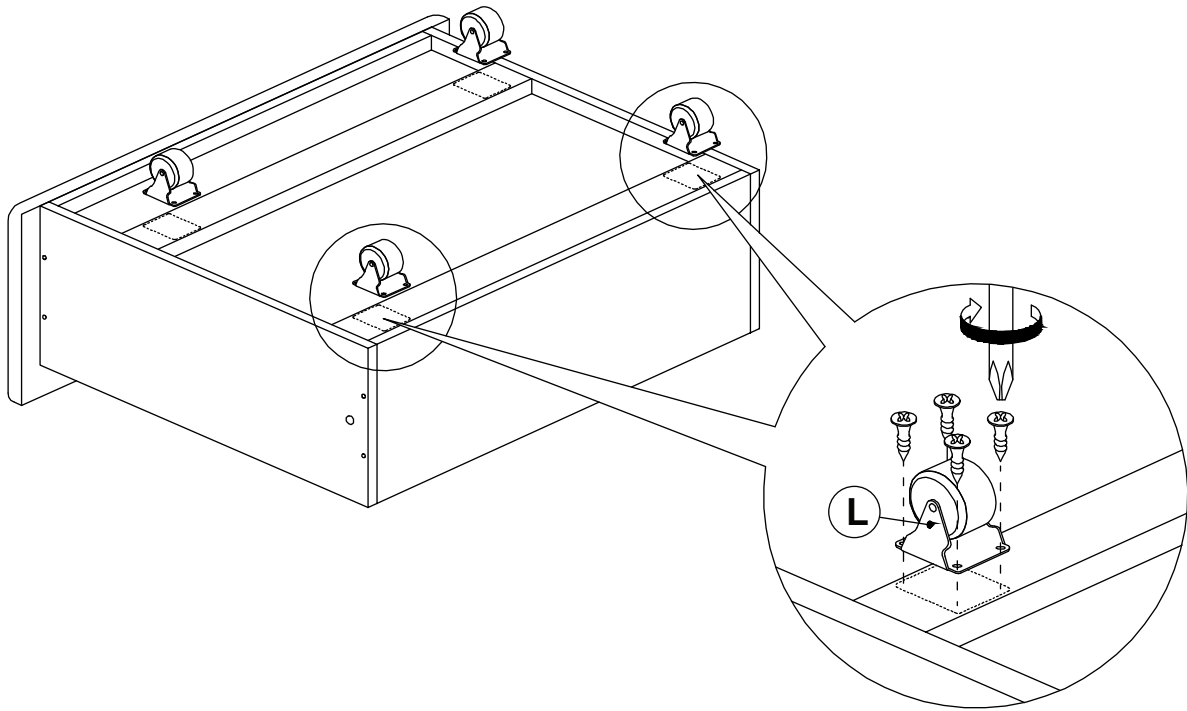

## STEP 12

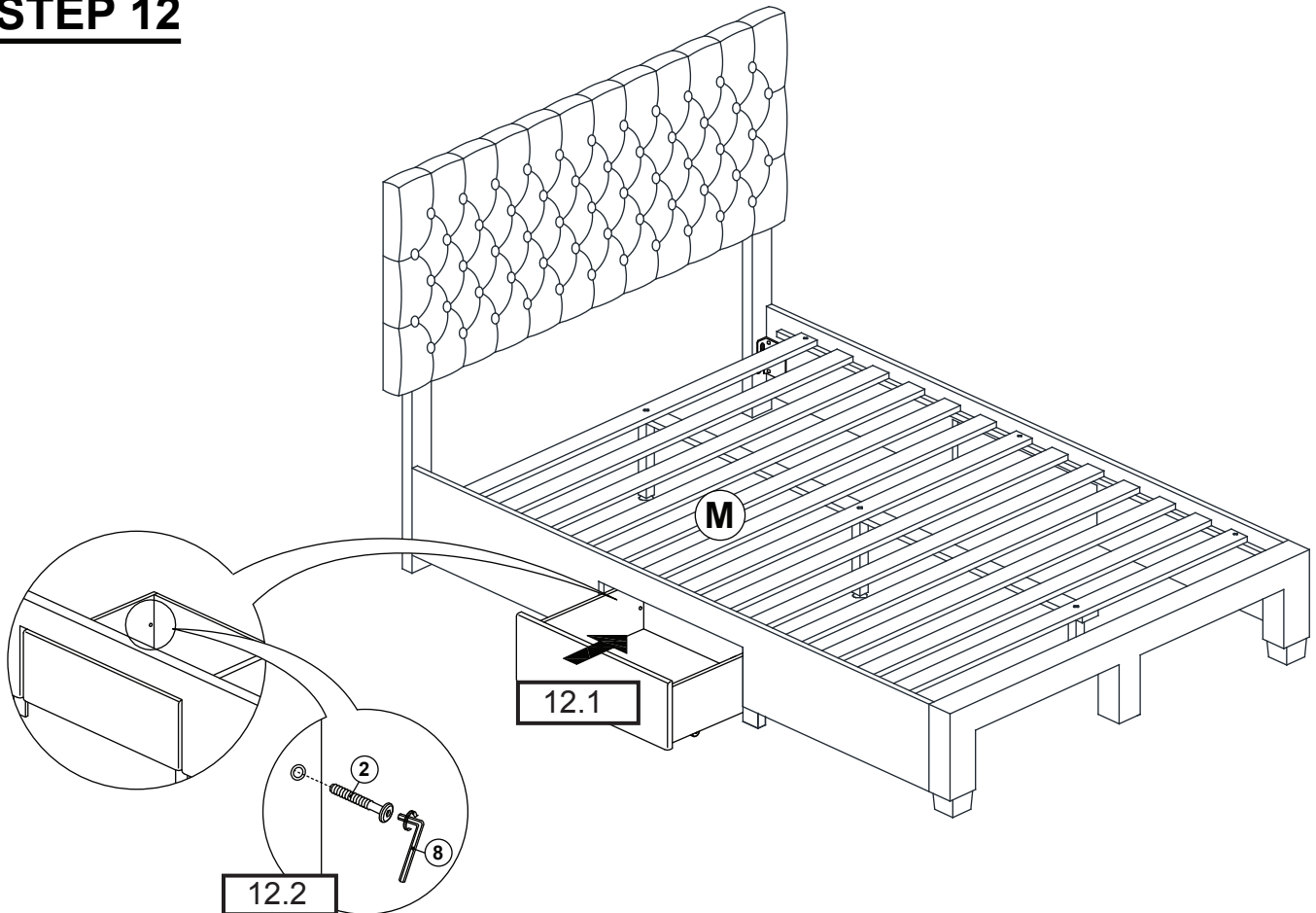

**ASSEMBLY INSTRUCTIONS**

**STEP 13**

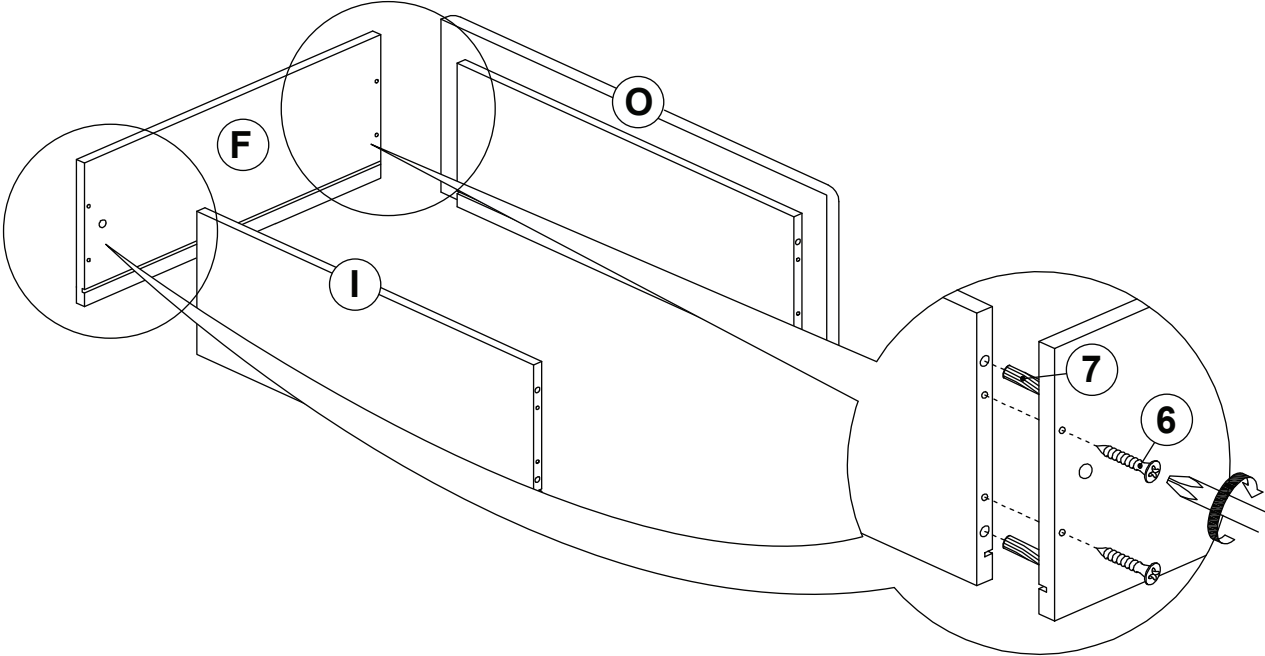

**STEP 14**

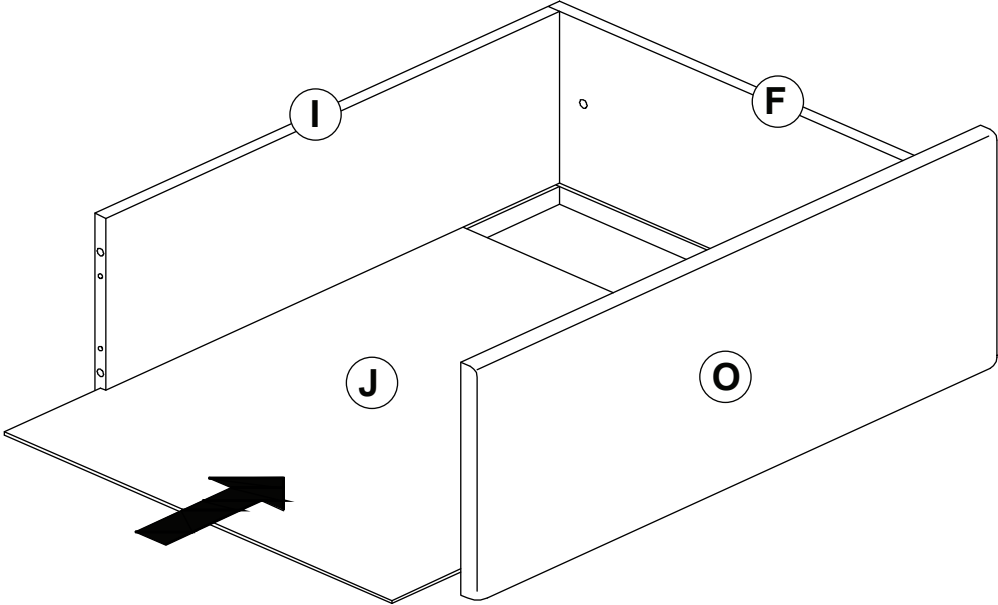

# ASSEMBLY INSTRUCTIONS

## STEP 15

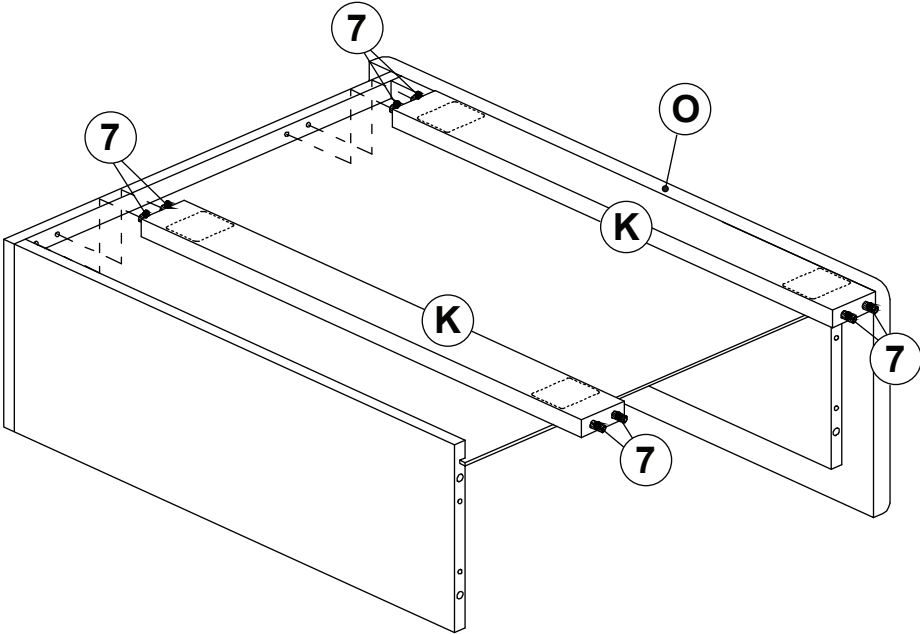

## STEP 16

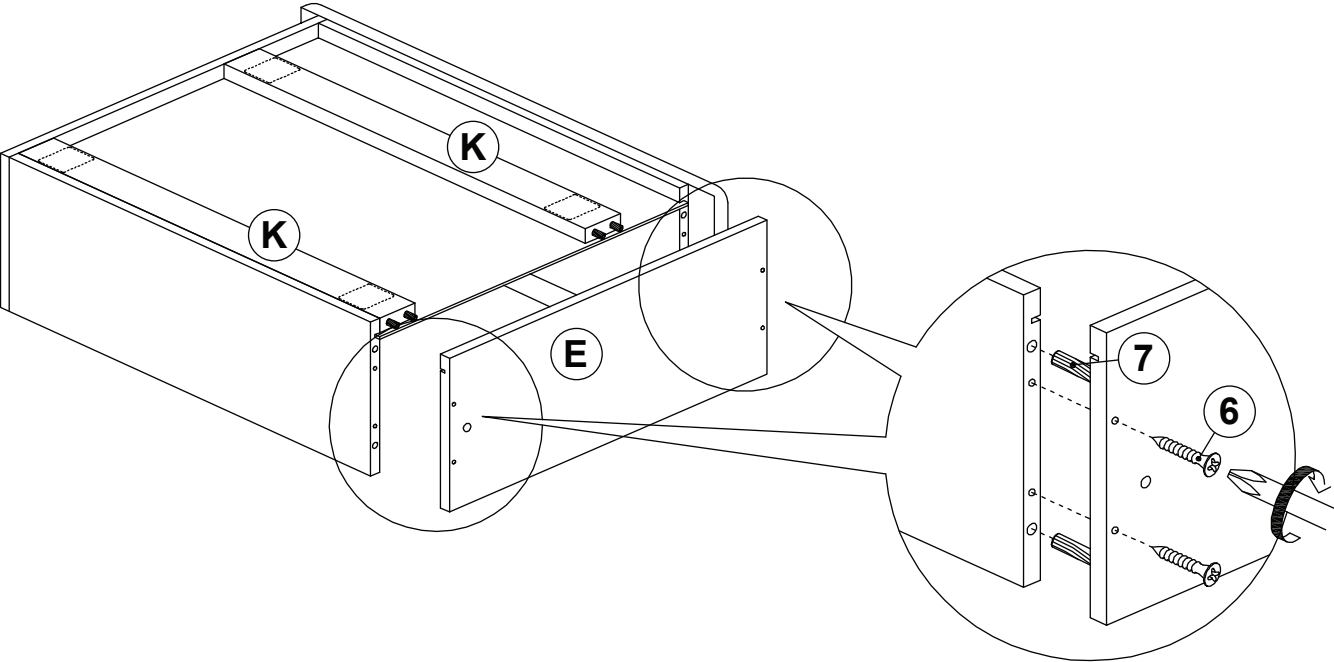

# ASSEMBLY INSTRUCTIONS

## STEP 17

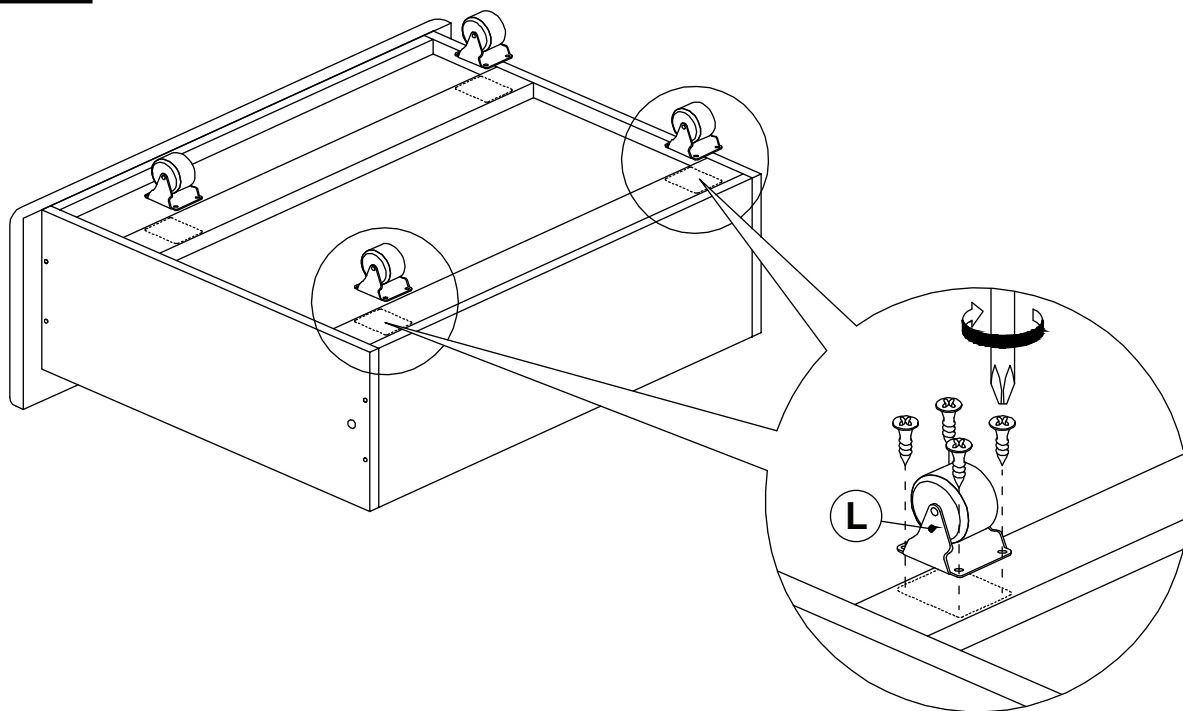

## STEP 18

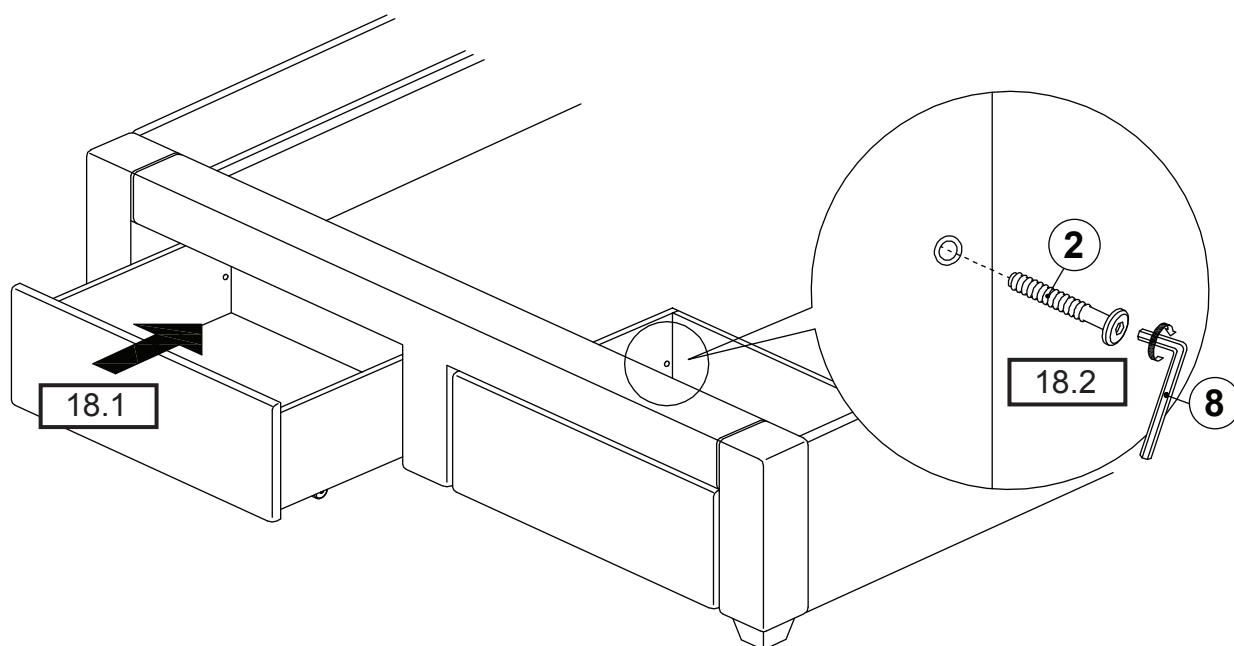

# ASSEMBLY INSTRUCTIONS

## STEP 19

## COMPLETE

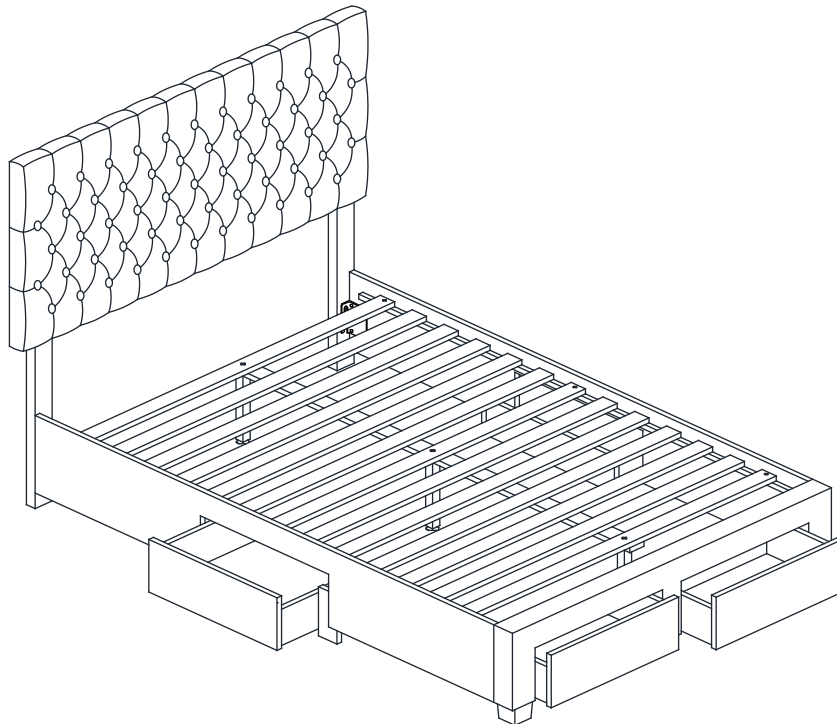

**Inner Size: 54.50"W X 76.00"D**

**Inner Size of Drawer (Front) : 19.50"W X 17.75"D X 6.00"H X 0.50"T**

**Inner Size of Drawer (Side) : 22.75"W X 17.75"D X 6.00"H X 0.50"T**

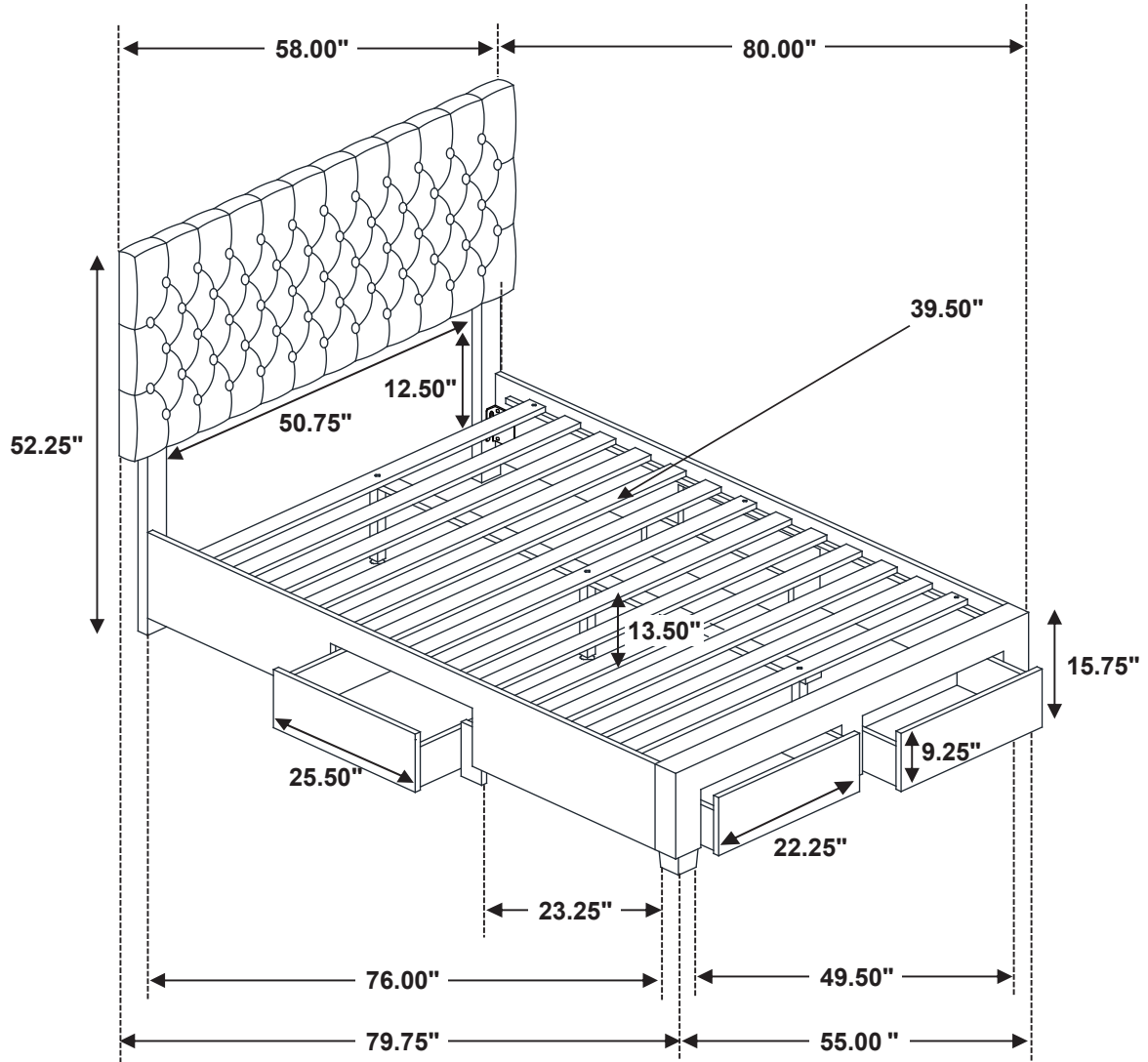

**Note: Dimension tolerance  $\pm 5\%$**