

Fabric Dresser

Installation Manual

Commode en tissu

Manuel d'installation

Stoffkommode

Installationsanleitung

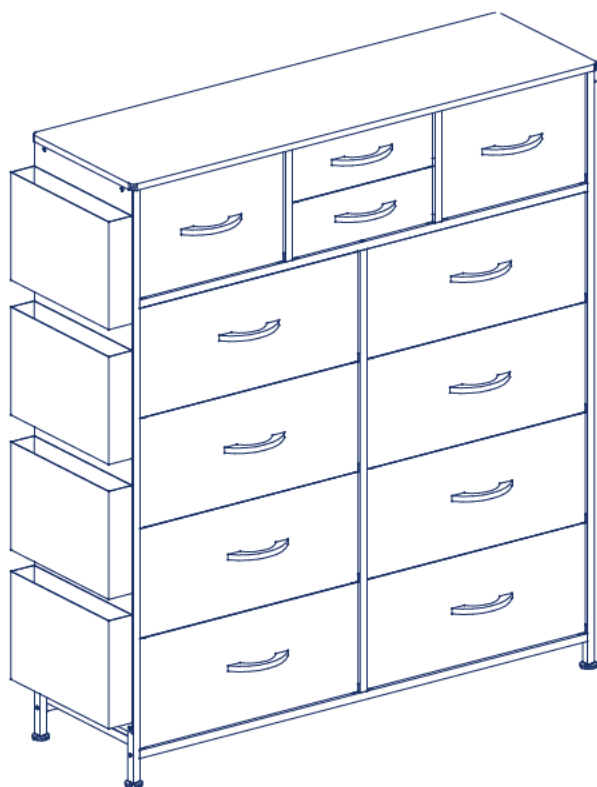

I EN03

II FR11

III DE21

EN



WARNING

The product must be assembled by adult before use.

Serious or fatal injury may occur from unexpected assembly or use.

1. During the assembly process, keep all parts away from babies or children.
2. Always securely fix this product to the wall. Make sure the wall area to be drilled is free from hidden electrical wires, water and gas pipes.
3. Use of tip-over restraints may only reduce, but not eliminate the risk of tip-over.
4. Unless specially designed to accommodate, do not set heavy objects on top of this product.
5. Place the heaviest items on the lowest layer.
6. Never allow children to climb or bump drawers, doors or shelves.

FR

Merci d'avoir acheté notre produit. S'il vous plaît contactez-nous si vous avez des difficultés avec assemblage ou besoin de pièces de remplacement.



ATTENTION

Le produit doit être assemblé par un adulte avant utilisation.

Des blessures graves ou mortelles peuvent survenir à cause de l'assemblage ou l'utilisation inattendue.

1. Pendant le processus de montage, gardez toutes les pièces loin des bébés et des enfants.
2. Fixez toujours sécuritairement ce produit au mur. Assurez-vous que la zone du mur à percer est libre de fils électriques cachés, de conduites d'eau et de gaz.
3. L'utilisation de dispositifs de retenue pour le renversement ne peut que réduire, mais pas éliminer le risque de renversement.
4. Sauf si spécialement conçu pour accueillir, ne posez pas d'objets lourds au sommet de ce produit.
5. Placez les articles les plus lourds sur la tablette la plus basse.
6. Ne laissez jamais les enfants grimper ou cogner sur les tiroirs, les portes ou les étagères.

IT

Grazie per aver acquistato il nostro prodotto. In caso dei problemi durante l'assemblaggio o la sostituzione, si prega di contattarci senza esitazione.



AVVERTIMENTO

Il prodotto deve essere assemblato da un adulto prima dell'uso.

L'inaspettato montaggio potrebbe provocare lesioni gravi o mortali.

1. Durante l'assemblaggio, metti tutti i parti fuori dalla portata dei bambini.
2. Sempre fissare saldamente questo prodotto alla parete. Assicurarsi che l'area della parete sia libera dai cavi elettrici nascosti, i tubi dell'acqua e del gas.
3. La restrizione punta-over può ridurre il rischio di punta-over ma non può eliminarlo.
4. A meno che con l'appositamente progettato, Non deporre gli oggetti pesanti sul piano superiore
5. Posiziona le robe più pesante al piano inferiore.
6. Non permettere i bambini di scalare o battere i cassetti, le porte o gli scaffali.

DE



WARNUNG

Der Produkt muss vor Gebrauch von einem Erwachsenen zusammgebaut werden.

Bei unerwarteter Montage oder Verwendung können schwere oder tödliche Verletzung auftreten.

1. Legen Sie in den Montageprozess alle Teile weg von Babys oder Kindern.
2. Befestigen Sie dieses Produkt sicher an der Wand. Um sicher zu stellen, dass der zu bohrende Wandbereich entfernt von verdeckten Stromkabeln, Wasser- und Gasleitungen ist.
3. Die Verwendung von Kippsicherungen kann die Gefahr eines Kippens nur verringern, jedoch nicht beseitigen.
4. Setzen Sie bitte keine schweren Gegenstände auf dieses Produkt, es sei denn, dass das Produkt speziell für die Unterbringung konzipiert wird.
5. Legen Sie bitte die schwersten Gegenstände auf das unterste Regal.
6. Erlauben Sie nie Kindern, auf Schubladen, Türen oder Regale zu klettern oder zu knallen.

ES

Gracias por adquirir nuestro producto. Por favor, póngase en contacto con nosotros si tiene dificultades con montaje o necesidad de repuestos.



ADVERTENCIA

El producto debe ser ensamblado por un adulto antes de su uso.

Se pueden producir lesiones graves o fatales debido al montaje o uso inesperado.

1. Durante el proceso de montaje, mantenga todas las piezas alejadas de bebés o niños.
2. Fije siempre este producto de forma segura a la pared. Asegúrese de que el área de la pared a perforar esté libre de cables eléctricos ocultos, tuberías de agua y gas.
3. El uso de restricciones de vuelco solo puede reducir, pero no elimina el riesgo de que se vuelque.
4. A menos que esté especialmente diseñado para acomodarse, no coloque objetos pesados encima de este producto.
5. Coloque los artículos más pesados en el estante más bajo.
6. Nunca permita que los niños se suban o golpeen los cajones, puertas o estantes.

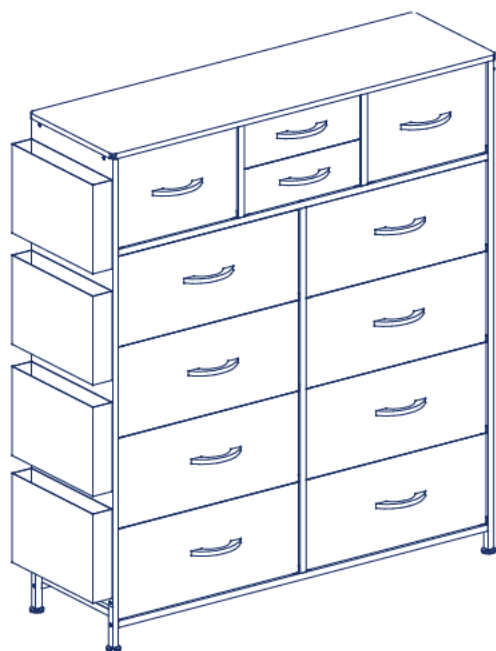

English

1	PRE-INSTALLATION PREPARATION -----	04
	1-1 Thank you for choosing our products -----	04
	1-2 Package contents-----	04
	1-3 Precautions -----	04
2	INSTALLING MODULES -----	05
	2-1 Product Assembly Diagram -----	05
	2-2 Suggestion-----	05
	2-3 Parts List -----	06
	2-4 Assembly Steps-----	07
3	CUSTOMER SERVICE -----	13
4	PROBLEMS YOU MAY ENCOUNTER -----	14

Before assembly, please read this Installation Manual first, and check according to Parts List to make sure all parts are included.

Package contents

Fabric Dresser with drawers

Assembly tools

Installation Manual

Precautions



Avoid long-term direct sunlight exposure.



Keep away from sharp objects.



Keep away from corrosive substances.



Keep infants/children away from assembled parts to avoid



This product must be assembled by an adult before use.



Never allow children to stand, climb or hang on drawers, doors or shelves.



Note that the wall to be drilled has no hidden electrical wires, water pipes and gas pipes.



When assembling the product, be careful of iron frames or iron pipes hitting people.



Pay attention to avoid over-tightening fasteners, or they may induce cracking within the board.

Product Assembly Diagram

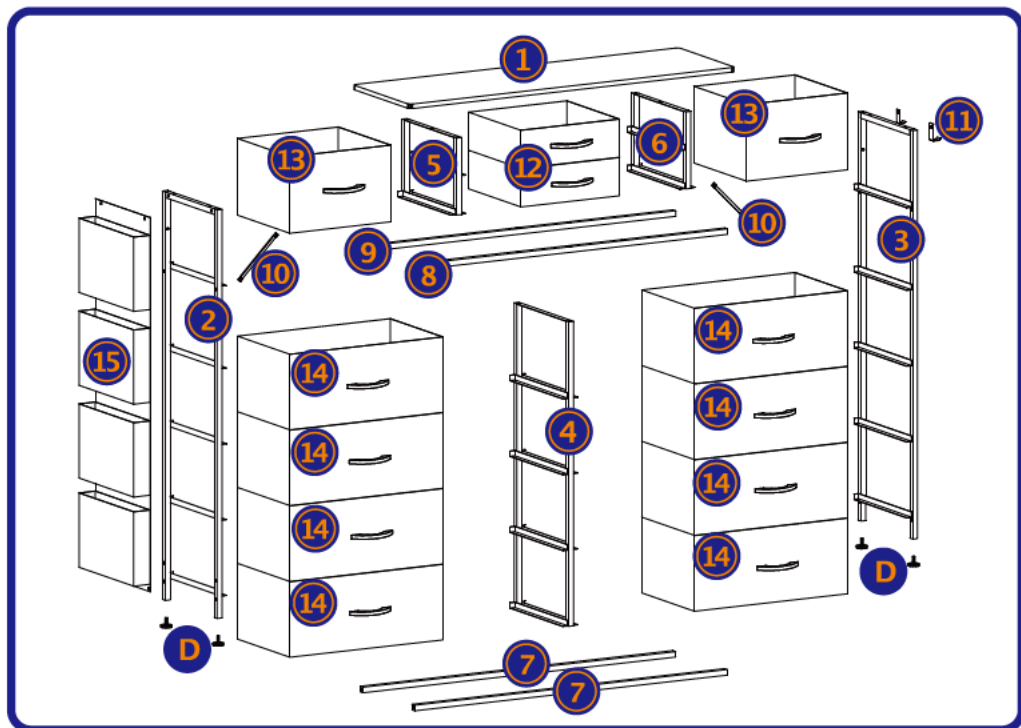











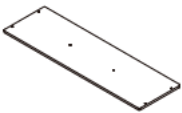

Suggestion

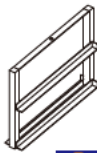
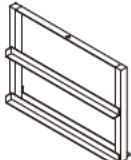





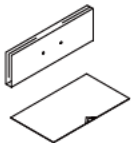
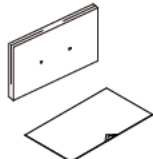
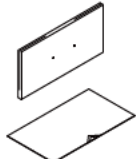



The installation takes 30 minutes



Parts List

 1 x1	 2 x1	 3 x1	 4 x1	 5 x1
 6 x1	 7 x2	 8 x1	 9 x1	 10 x2
 11 x2	 12 x2	 13 x2	 14 x8	 15 x1

 M6x10 A x12	 M6x23 B x20	 M4x12 C x24	 M6 D x4	 E x12
 Anti-tip protection F x1				

Assembly Steps

STEP1 Note:the guide rails are in the same direction

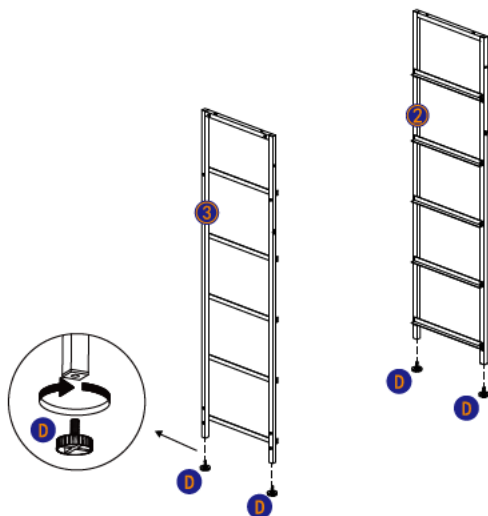
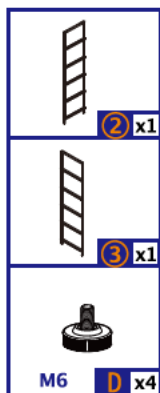

STEP2 Note:the guide rails are in the same direction

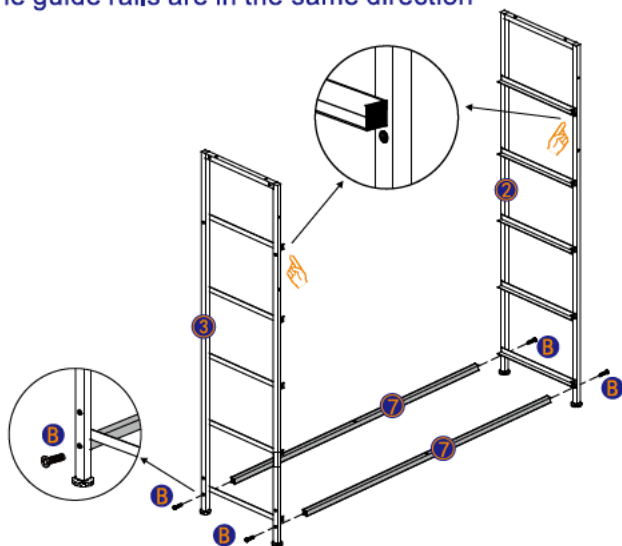
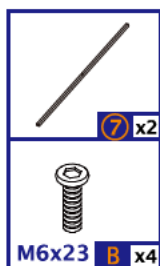

Assembly Steps

STEP 3

Note: the guide rails are in the same direction

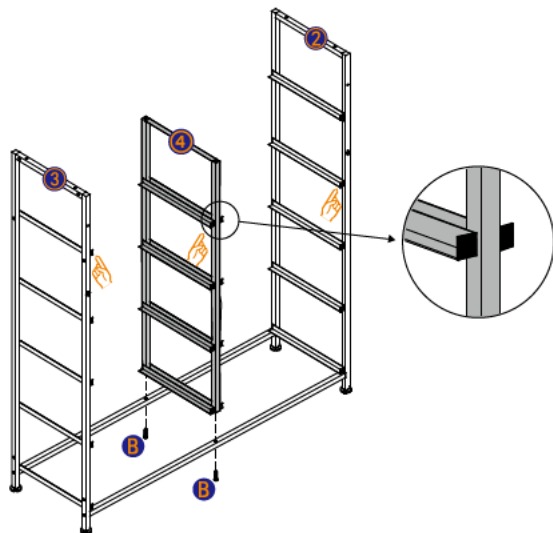
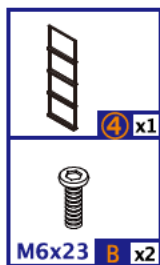

STEP 4

Pay attention to the location of the two tubes during installation

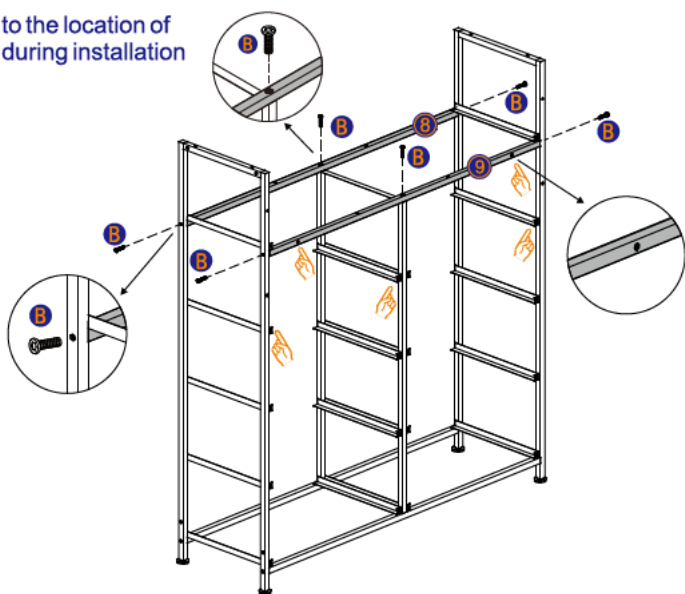
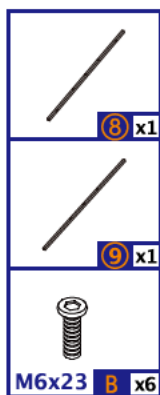

Assembly Steps

STEP 5 Note: the guide rails are in the same direction

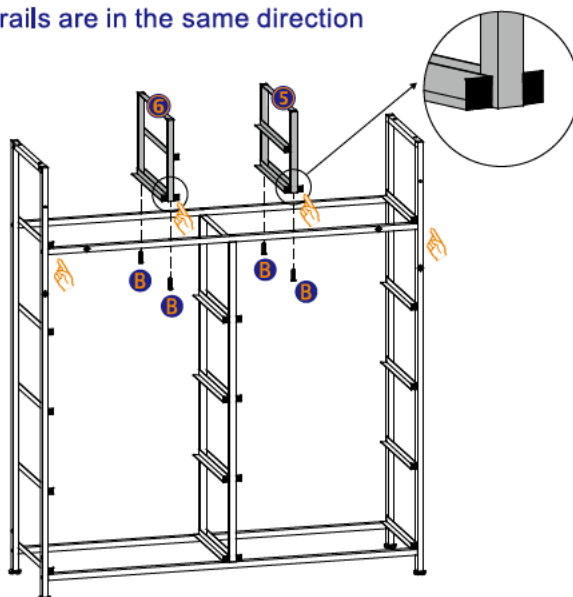
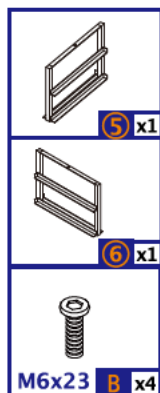

STEP 6

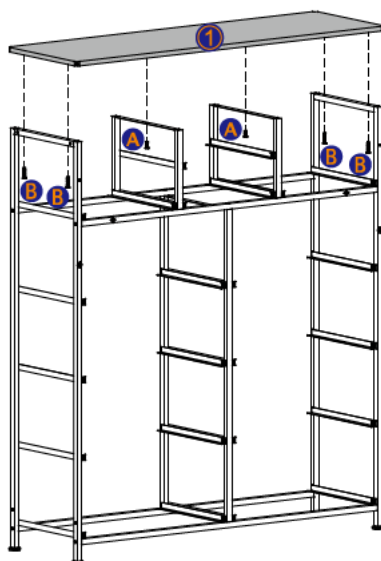

Assembly Steps

STEP 7

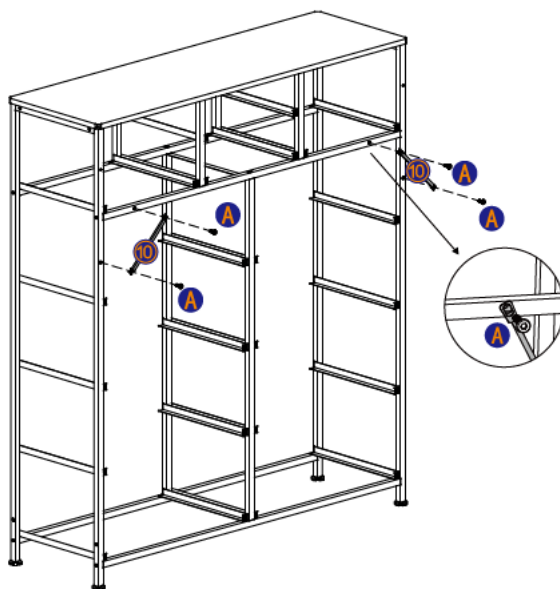
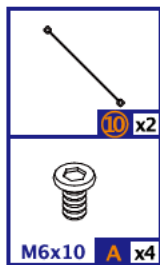

STEP 8

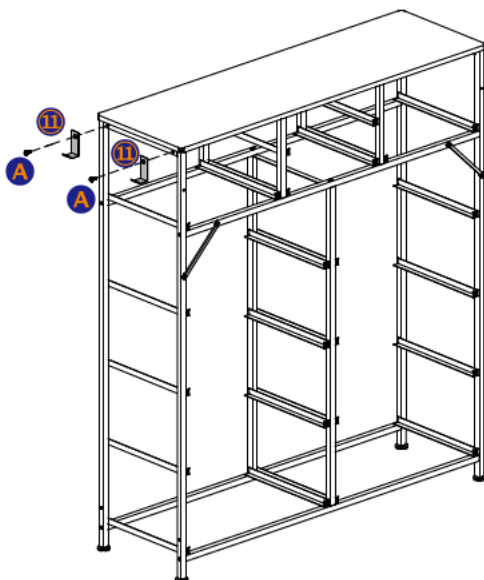
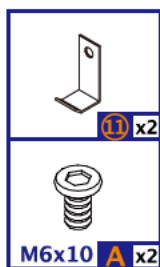

Assembly Steps

STEP 9

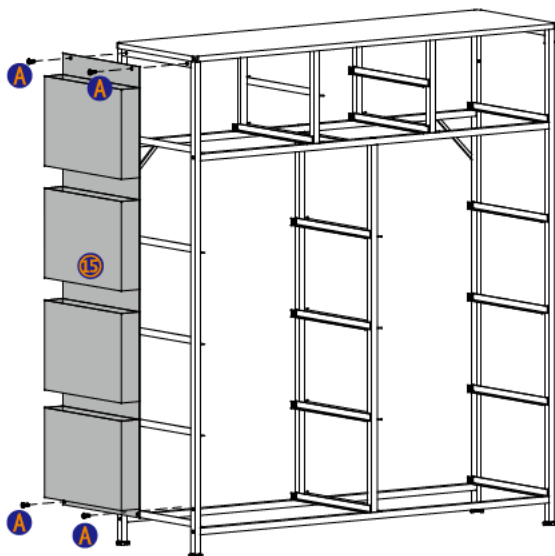
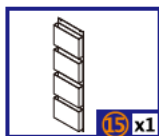

STEP 10

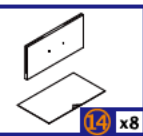
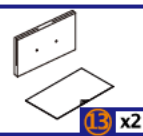
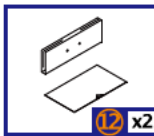
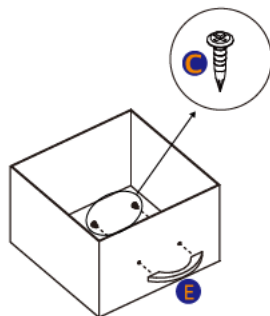
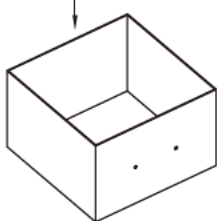
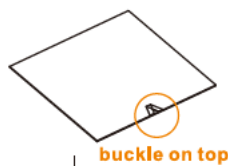
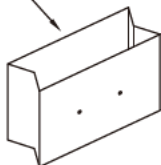
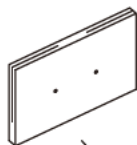

Assembly Steps

STEP 11

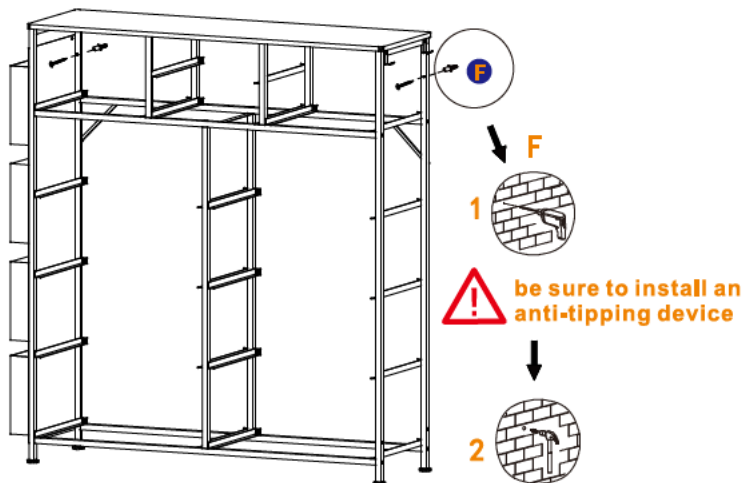

PROBLEMS YOU MAY ENCOUNTER

PART	PROBLEM	SOLUTION
ALL Product	Parts are missing, defective or having wrong parts in package	You can contact us via purchasing platform or
	Having issue(s) while reading the instruction or completing the assembly.	
	Encountering non-human caused damage during usage.	If the product is damaged due to non-human causes, please keep the product and send us photos of it. We will ascertain the cause of the product damage within 48 hours and provide you with a satisfactory solution.
Fabric Dresser Surface	Board Surface is broken, scratched or lack of some screw holes.	You can contact us and we will get back to you within 24 hours. Or, you can reach us via after-sales email.
	The screw holes that Table on the board and the Surface steel frame don't line up.	1. Please tighten the screws on the board by 70%, do not tighten completely. 2. Adjusting board and steel frame until the screw holes are lined up, then tighten all the screws.
	The Fabric Dresser is uneven or not tight that has gaps after being assembled.	1. Loosen the screws in the uneven or gap positions; adjust until the desktops are flat and tight, and then tighten the screws. 2. If your problem still can't be solved, please feel free to contact us.
Steel Frame	The Fabric Dresser is uneven or not tight that has gaps after being assembled.	You can contact us and we will get back to you within 24 hours. Or, you can reach us via after-sales email.
	The product is unstable after being assembled.	1. Check if the screws are tightened. 2. Read throughout the manual, check are there any parts installed incorrectly or missing assembled. 3. If your problem still can't be solved, please feel free to contact us.
	Encountering non-human caused damage during usage.	If the product is damaged due to non-human causes, please keep the product and send us photos of it. We will ascertain the cause of the product damage within 48 hours and provide you with a satisfactory solution.
Drawer	Broken, dirty or missing	You can contact us and we will get back to you within 24 hours. Or, you can reach us via after-sales email.

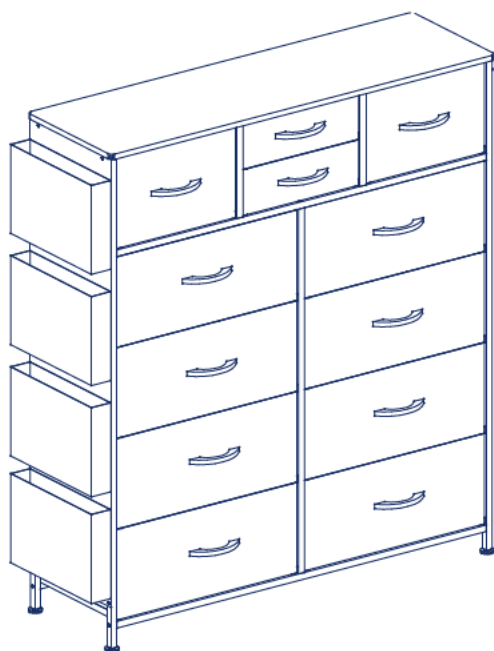

French

1	PRÉPARATION AVANT L'INSTALLATION -----	16
	1-1Merci d'avoir choisi nos produits -----	16
	1-2Contenu de l'emballage -----	16
	1-3Précautions -----	16
2	INSTALLATION DU MODULE -----	17
	2-1Diagramme d'assemblage du produit -----	17
	2-2Suggestion -----	17
	2-3Liste des pièces -----	18
	2-4Étapes d'assemblage -----	19
3	SERVICE CLIENT -----	25
4	PROBLÈMES QUE VOUS POURRIEZ RENCONTRER ---	26

Merci d'avoir choisi nos produits

Avant l'assemblage, veuillez lire ce Manuel d'installation en premier lieu et vérifier selon la Liste des pièces pour vous assurer que toutes les pièces sont incluses.

Notre adresse e-mail de contact est [VIP](mailto:VIP@vip.com)

s à nous

contacter si vous avez des préoccupations ou des questions concernant votre produit, nous sommes toujours prêts à vous aider. Votre satisfaction est notre priorité absolue.

Contenu de l'emballage

Commode en tissu avec tiroirs

Outils d'assemblage

Manuel d'installation

Précautions



Évitez une exposition prolongée au soleil direct.



Gardez-vous des objets tranchants.



Éloignez-vous des substances corrosives.



Éloignez les nourrissons/enfants de ces assemblés pour éviter tout risque d'étouffement.



Ce produit doit être assemblé par un adulte avant utilisation.



Ne laissez jamais les enfants se tenir debout, grimper ou s'accrocher aux tiroirs, aux portes ou aux étagères.



Notez que le mur à percer ne comporte pas de fils électriques cachés, de tuyaux d'eau et de tuyaux de gaz.



Lors de l'assemblage du produit, faites attention aux cadres en fer ou aux tuyaux en fer qui pourraient heurter les personnes.



Faites attention pour éviter de trop serrer les fixations, sinon elles pourraient provoquer des fissures dans la planche.

Diagramme d'assemblage du produit

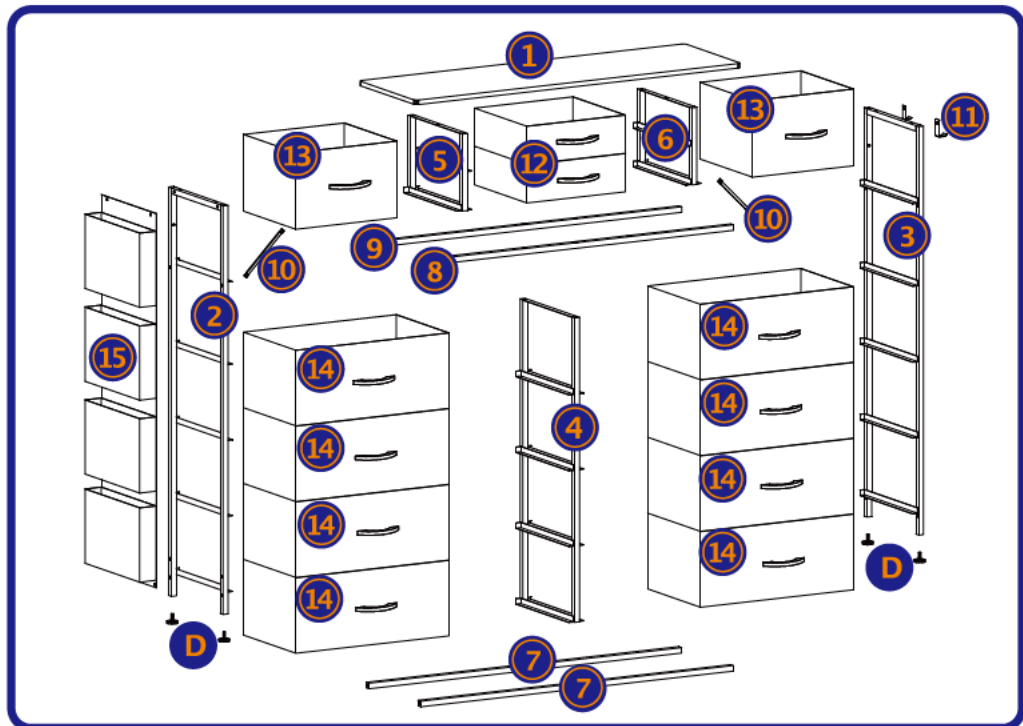

Suggestion



L'installation prend
30 minutes











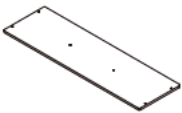



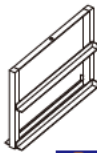
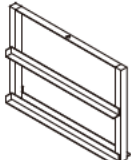



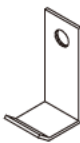
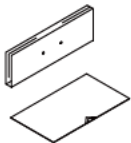
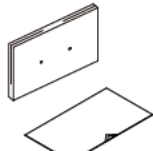
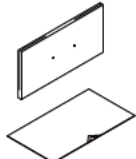

Pour votre
confort et votre
sécurité, nous
recommandons
deux personnes
pour l'assemblage



Assemblez-le en
sélectionnant la
perceuse selon
nos spécifications
de montage
manuel

Liste des pièces

 1 x1	 2 x1	 3 x1	 4 x1	 5 x1
 6 x1	 7 x2	 8 x1	 9 x1	 10 x2
 11 x2	 12 x2	 13 x2	 14 x8	 15 x1

 M6x10 A x12	 M6x23 B x20	 M4x12 C x24	 M6 D x4	 E x12
 M6x30 x2  M4x50 x2				
Protection anti-basculement F x1				

ÉTAPE 1 Remarque : les rails de guidage sont dans la même direction

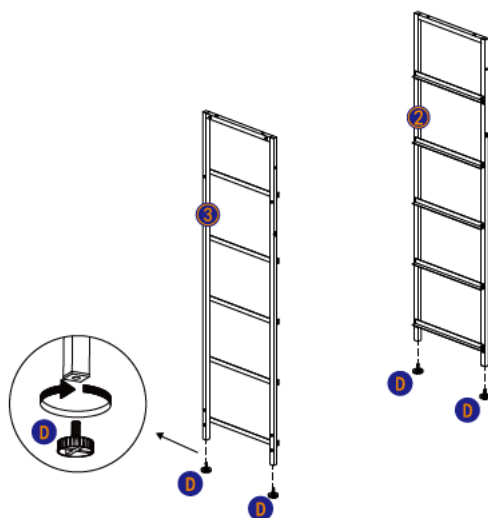
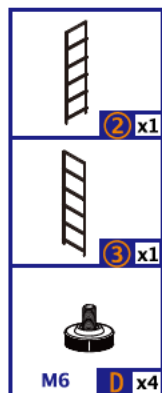

ÉTAPE 2 Remarque : les rails de guidage sont dans la même direction

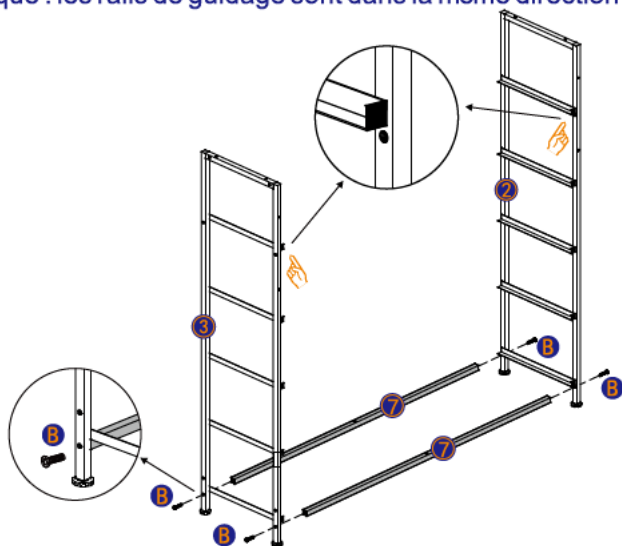
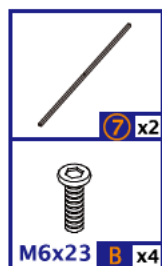

ÉTAPE 3

Remarque : les rails de guidage sont dans la même direction

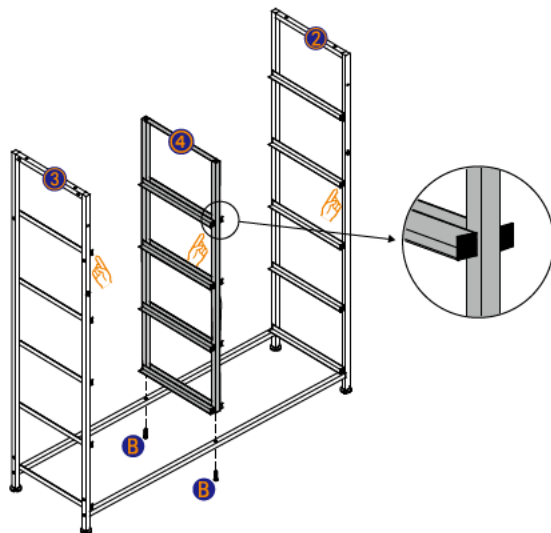
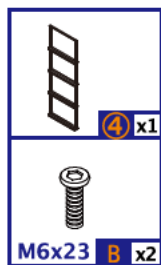

ÉTAPE 4

Faites attention à l'emplacement des deux tubes lors de l'installation.

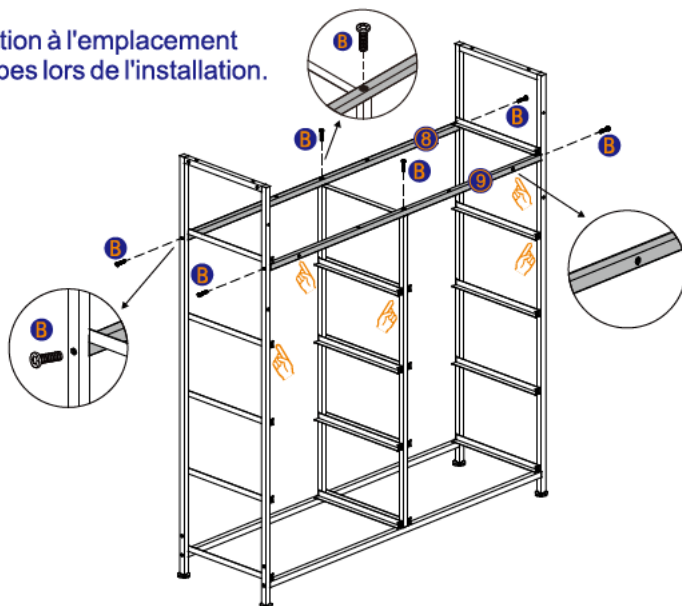
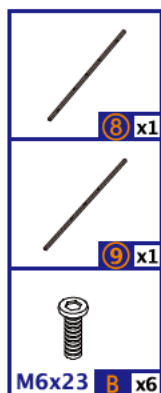

ÉTAPE 5 Remarque : les rails de guidage sont dans la même direction

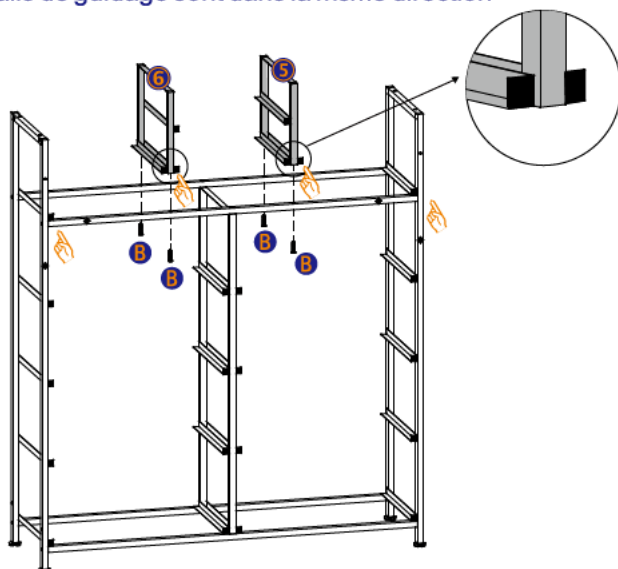
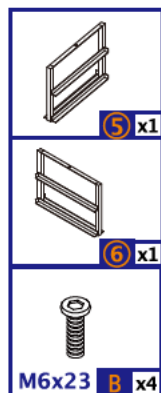

ÉTAPE 6

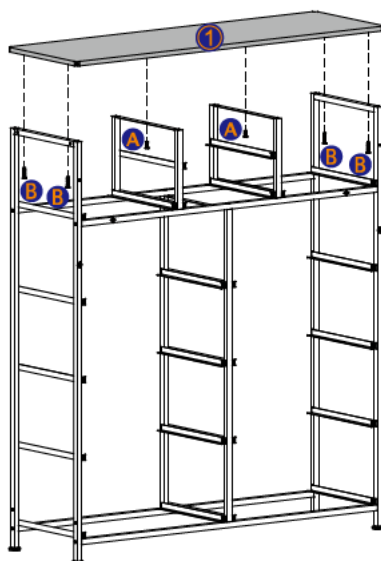

ÉTAPE 7

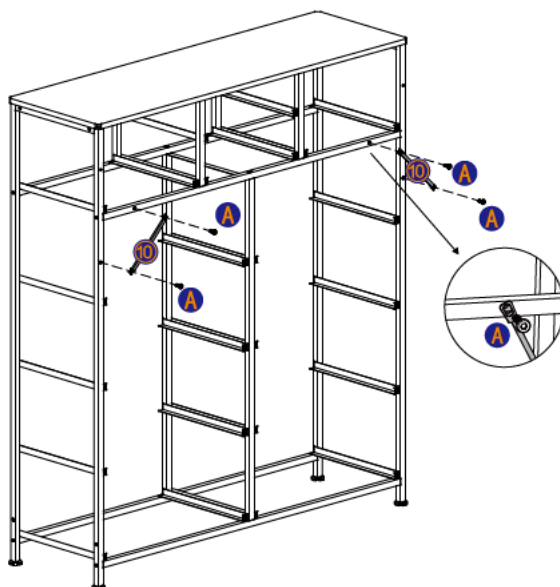
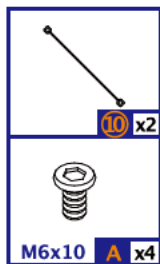

ÉTAPE 8

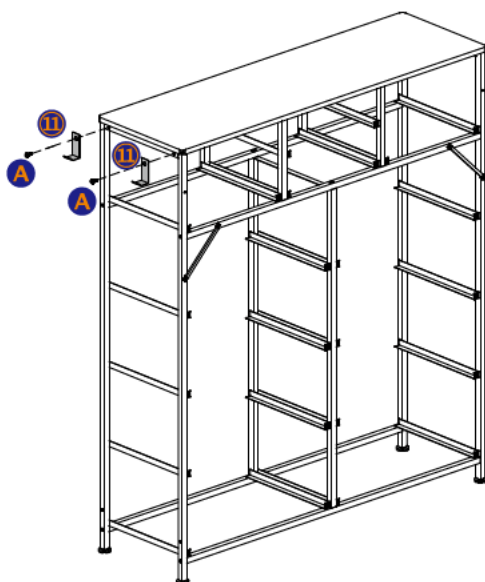
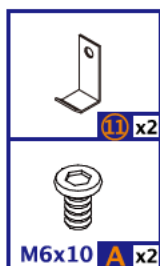

ÉTAPE 9

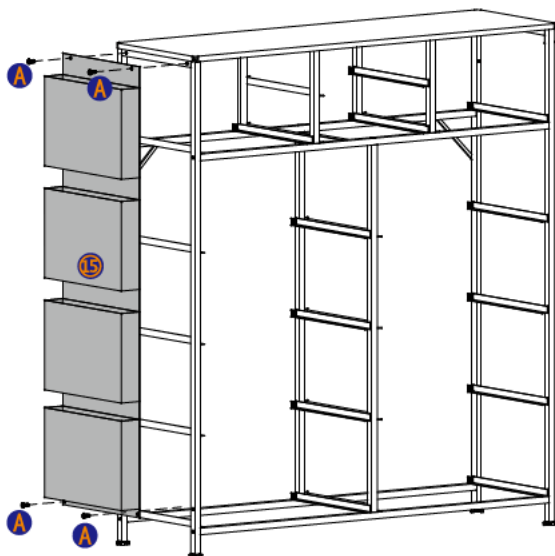
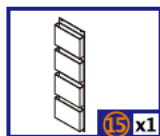

ÉTAPE 10

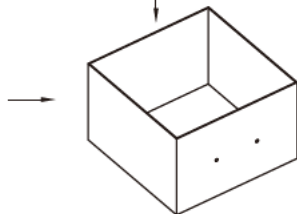
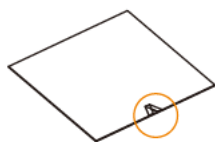
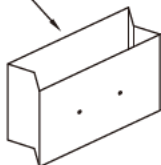
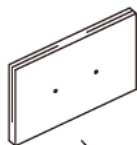

Boucle en haut

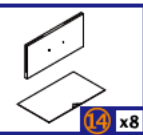
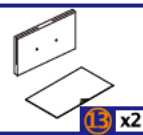
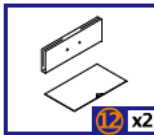
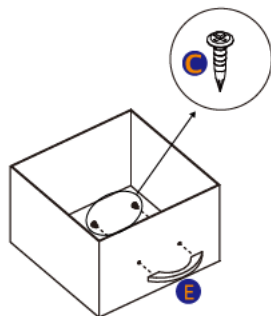

ÉTAPE 11

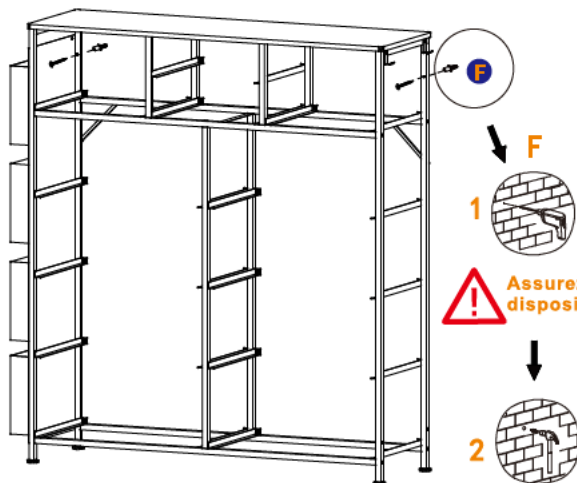

PIÈCE	PROBLÈME	SOLUTION
Tout le produit	Des pièces sont manquantes, défectueuses ou ont été mal emballées.	
	Rencontrer des problèmes en lisant les instructions ou en complétant l'assemblage.	
	Rencontrer des dommages non causés par l'homme pendant l'utilisation.	Si le produit est endommagé pour des raisons non humaines, veuillez conserver le produit et nous envoyer des photos. Nous déterminerons la cause des dommages dans les 48 heures et vous fournirons une solution satisfaisante.
Surface du meuble en tissu	La surface de la planche est cassée, rayée ou manque de trous de vis	Vous pouvez nous contacter et nous vous répondrons dans les 24 heures. Vous pouvez également nous joindre par e-mail après-vente.
	Les trous de vis sur la planche et le cadre en acier de la surface ne sont pas alignés.	<ol style="list-style-type: none"> 1. Veuillez serrer les vis de la planche à 70%, ne serrez pas complètement. 2. Ajustez la planche et le cadre en acier jusqu'à ce que les trous de vis soient alignés, puis serrez toutes les vis.
	Le meuble en tissu est inégal ou pas assez serré, il y a des écarts après assemblage.	<ol style="list-style-type: none"> 1. Desserrez les vis aux positions inégales ou avec des espaces ; ajustez jusqu'à ce que les dessus de table soient plats et serrés, puis serrez les vis. 2. Si votre problème ne peut toujours pas être résolu, n'hésitez pas à nous contacter.
Cadre en acier	Le meuble en tissu est inégal ou pas assez serré, il y a des écarts après assemblage.	Vous pouvez nous contacter et nous vous répondrons dans les 24 heures. Vous pouvez également nous joindre par e-mail après-vente.
	Le produit est instable après l'assemblage.	<ol style="list-style-type: none"> 1. Vérifiez si les vis sont serrées. 2. Lisez attentivement le manuel, vérifiez si certaines pièces sont mal installées ou manquantes. 3. Si votre problème ne peut toujours pas être résolu, n'hésitez pas à nous contacter.
	Rencontrer des dommages non causés par l'homme pendant l'utilisation.	Si le produit est endommagé pour des raisons non humaines, veuillez conserver le produit et nous envoyer des photos. Nous déterminerons la cause des dommages dans les 48 heures et vous fournirons une solution satisfaisante.
Tiroir	Cassé, sale ou manquant.	Vous pouvez nous contacter et nous vous répondrons dans les 24 heures. Vous pouvez également nous joindre par e-mail après-vente.

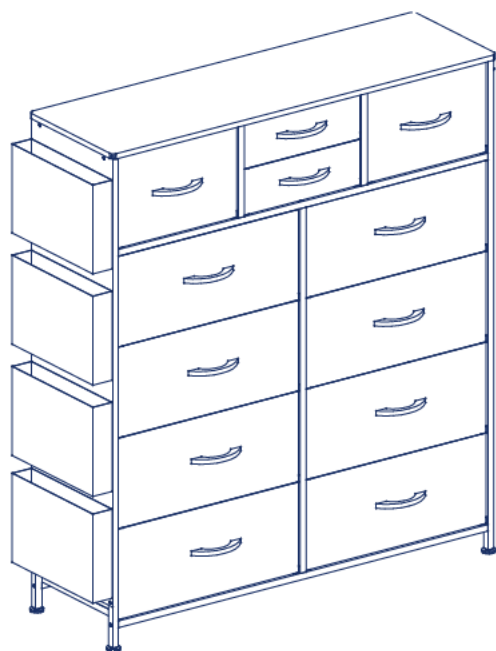

Deutsch

1	VORBEREITUNG VOR DER INSTALLATION	28
	1-1 Vielen Dank, dass Sie sich für unsere Produkte entschieden haben	28
	1-2 Verpackungsinhalt	28
	1-3 Vorsichtsmaßnahmen	28
2	MODUL INSTALLIEREN	29
	2-1 Produktmontage-Diagramm	29
	2-2 Vorschlag	29
	2-3 Teileliste	30
	2-4 Montageschritte	31
3	KUNDENDIENST	37
4	PROBLEME, DIE SIE VIELLEICHT ERLEBEN	38

Verpackungsinhalt

Stoffkommode mit Schubladen

Montagewerkzeuge

INSTALLATIONSANLEITUNG

Vorsichtsmaßnahmen



Vermeiden Sie langfristige direkte Sonneneinstrahlung.



Halten Sie sich von scharfen Gegenständen fern.



Halten Sie sich von korrosiven Substanzen fern.



Halten Sie Säuglinge/Kinder von montierten Teilen fern, um Erstickengefahr zu vermeiden.



Dieses Produkt muss vor der Verwendung von einem Erwachsenen zusammengebaut werden.



Lassen Sie niemals Kinder auf Schubladen, Türen oder Regalen stehen, klettern oder sich daran aufhängen.



Beachten Sie, dass die zu bohrende Wand keine versteckten elektrischen Leitungen, Wasserrohre und Gasleitungen hat.



Beim Zusammenbau des Produkts achten Sie darauf, dass Eisenrahmen oder Eisenrohre keine Menschen treffen.



Achten Sie darauf, die Befestigungen nicht zu fest anzuziehen, da dies zu Rissen in der Platte führen könnte.

Produktmontage-Diagramm

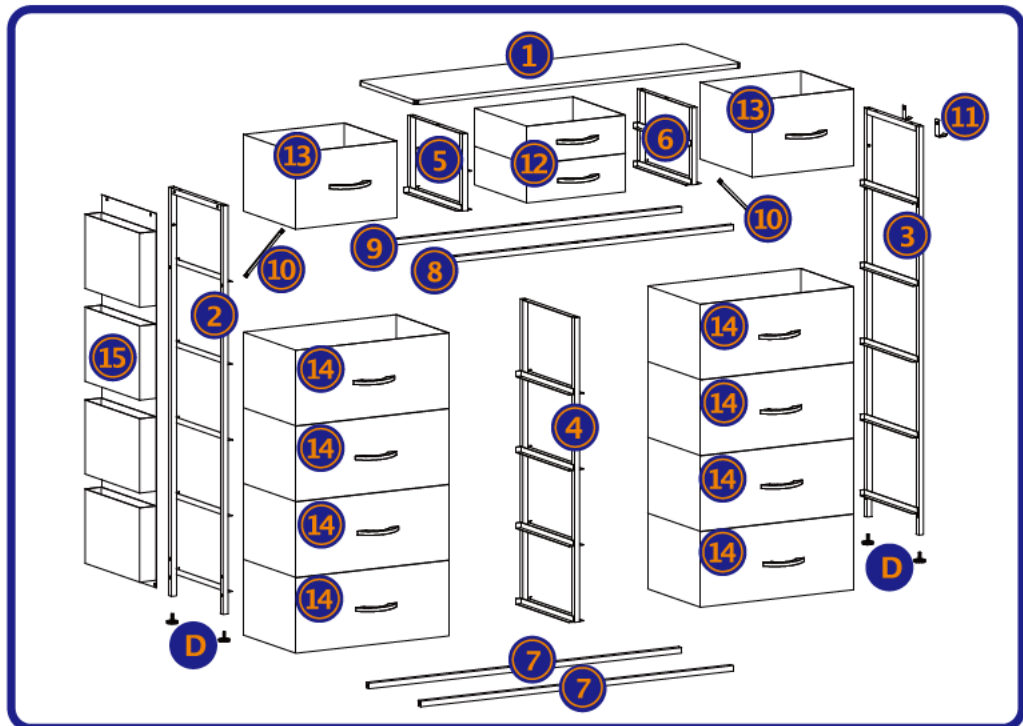

Vorschlag



Die Installation dauert 30 Minuten











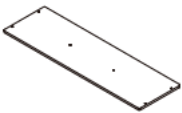



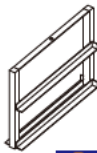
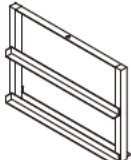





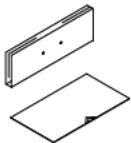
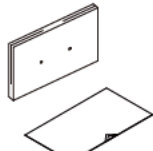
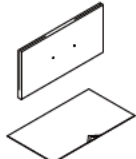

Zur Bequemlichkeit und Sicherheit empfehlen wir zwei Personen für die Montage



Montieren Sie es, indem Sie den Bohrer entsprechend unseren manuellen Montagespezifikationen auswählen

Teilleiste

 1 x1	 2 x1	 3 x1	 4 x1	 5 x1
 6 x1	 7 x2	 8 x1	 9 x1	 10 x2
 11 x2	 12 x2	 13 x2	 14 x8	 15 x1

 M6x10 A x12	 M6x23 B x20	 M4x12 C x24	 M6 D x4	 E x12
 M6x30 x2  M4x50 x2 Kippschutz F x1				

SCHRITT 1

Hinweis: Die Führungsschienen sind in die gleiche Richtung ausgerichtet

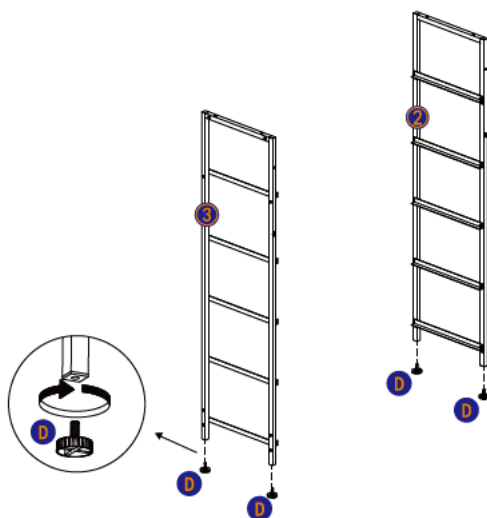
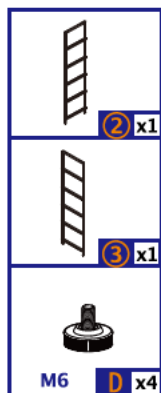

SCHRITT 2

Hinweis: Die Führungsschienen sind in die gleiche Richtung ausgerichtet

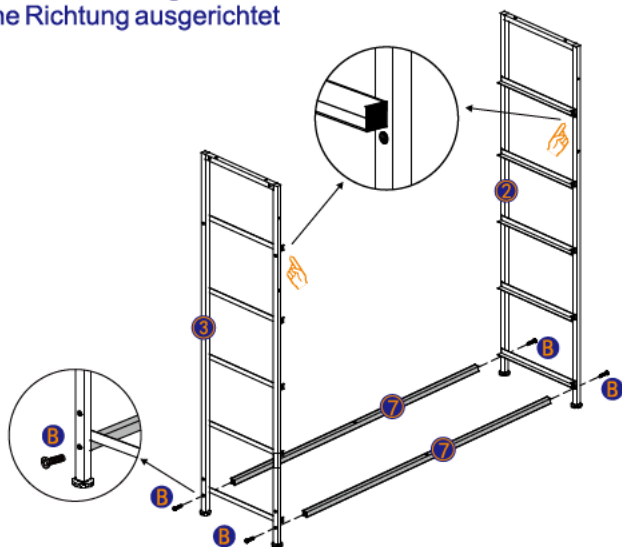
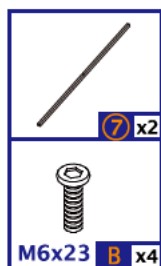

SCHRITT 3

Hinweis: Die Führungsschienen sind in die gleiche Richtung ausgerichtet

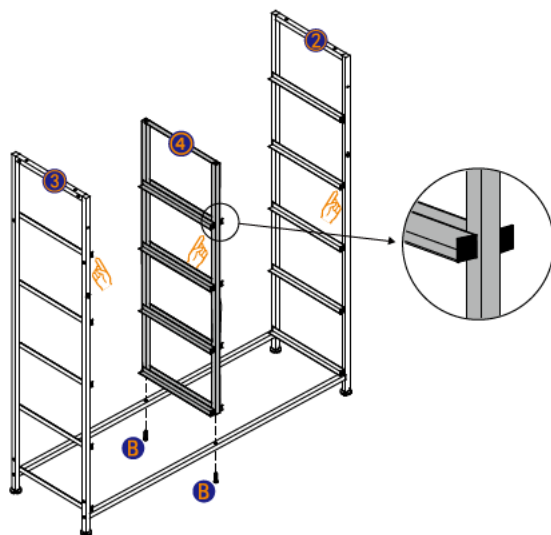
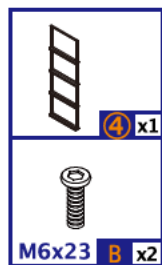

SCHRITT 4

Achten Sie auf die Position der beiden Rohre während der Installation.

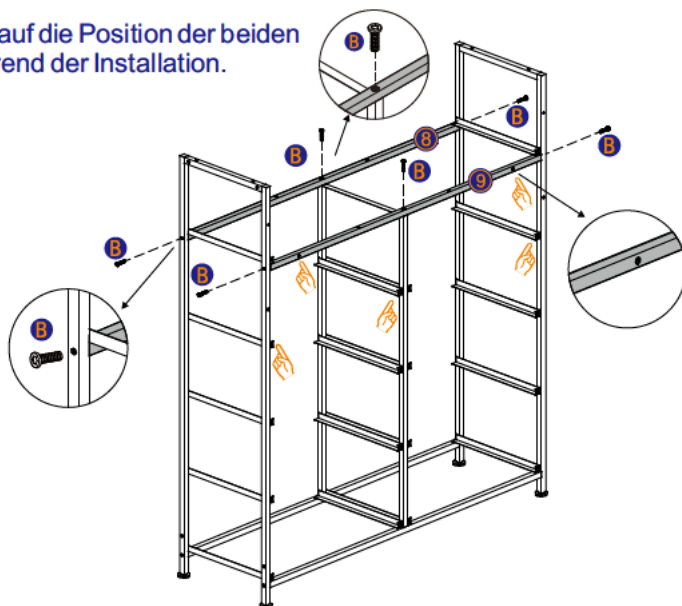
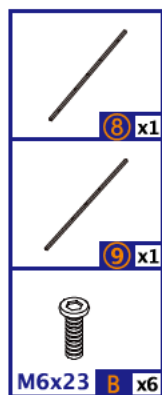

SCHRITT 5 Hinweis: Die Führungsschienen sind in die gleiche Richtung ausgerichtet

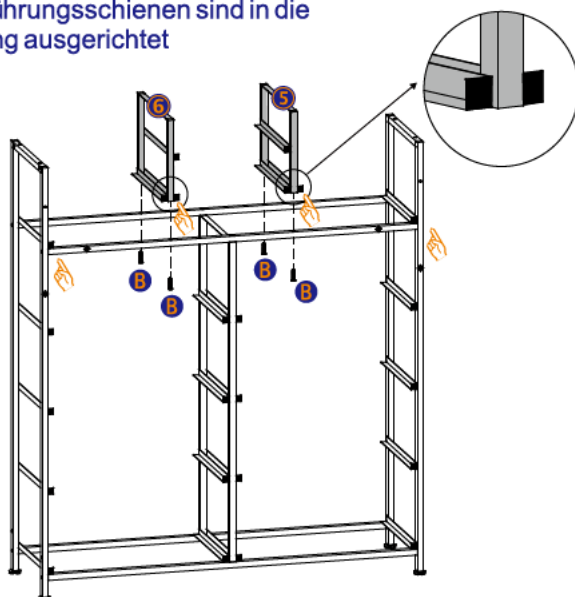
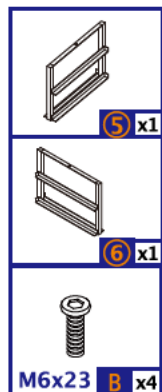

SCHRITT 6

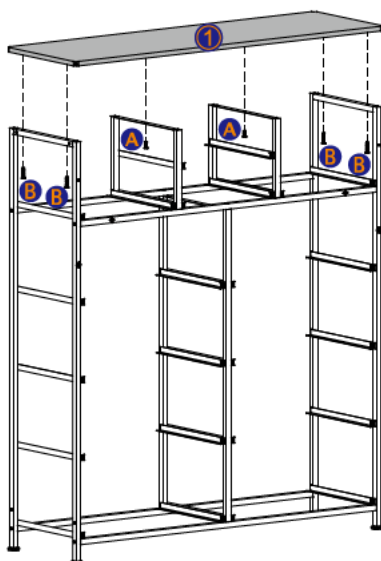

SCHRITT 7

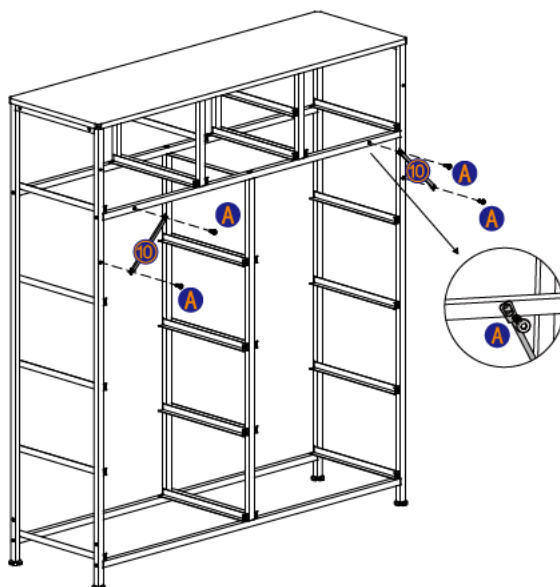
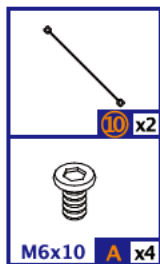

SCHRITT 8

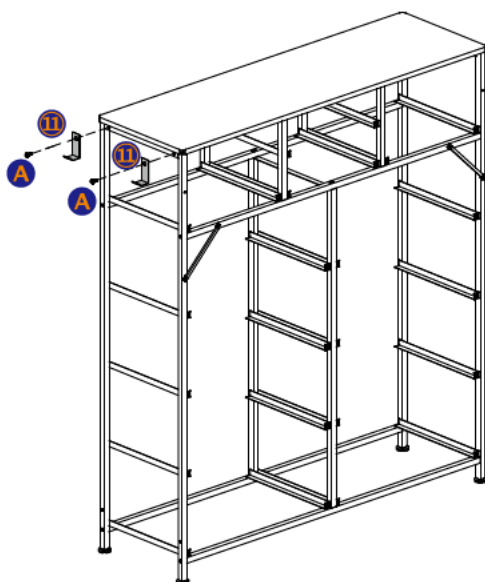
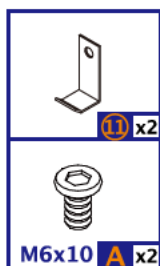

SCHRITT 9

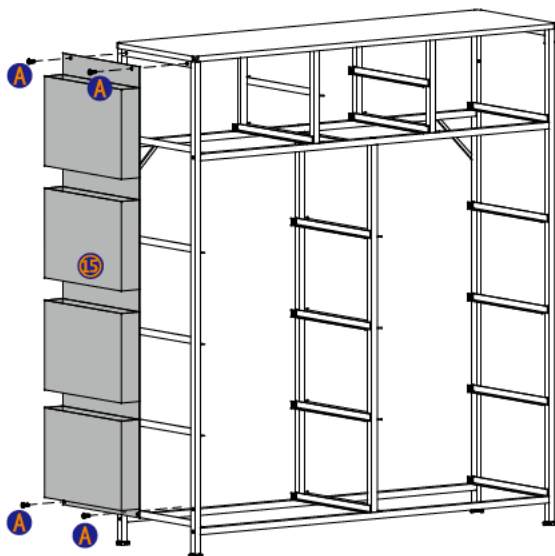
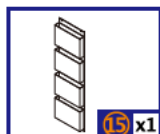

SCHRITT 10

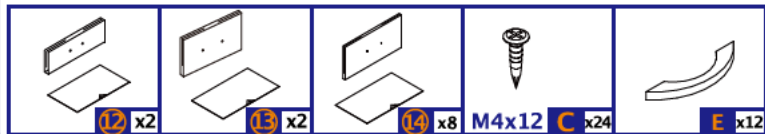
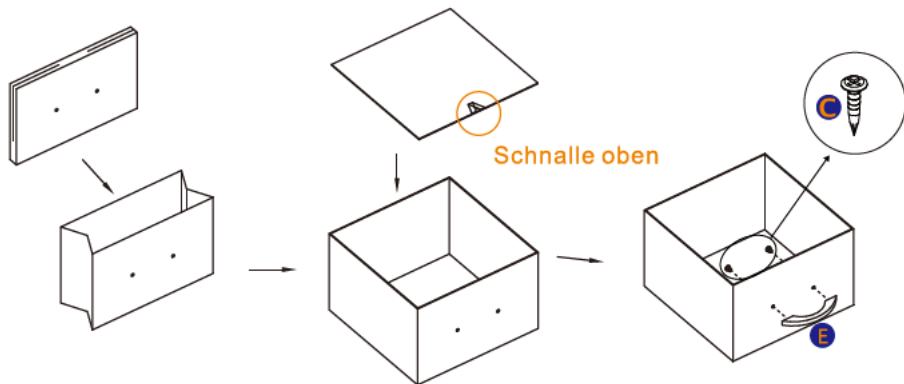

SCHRITT 11

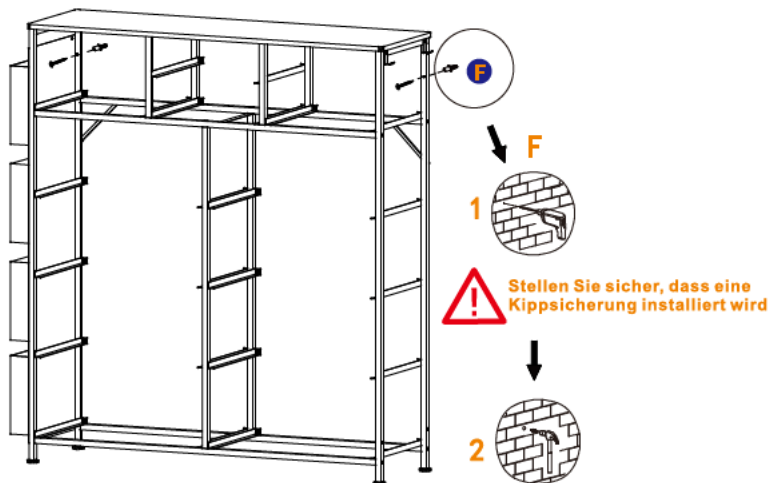

PROBLEME, DIE SIE VIELLEICHT ERLEBEN

TEIL	PROBLEM	LÖSUNG
Gesamtes Produkt	Teile fehlen, sind defekt oder falsche Teile im Paket	
	Probleme beim Lesen der Anleitung oder beim Zusammenbau haben.	
	Nicht durch den Menschen verursachte Schäden während der Nutzung	Wenn das Produkt aus nicht menschlichen Gründen beschädigt ist, behalten Sie bitte das Produkt und senden Sie uns Fotos davon. Wir werden die Ursache des Schadens innerhalb von 48 Stunden feststellen und Ihnen eine zufriedenstellende Lösung bieten.
Oberfläche des Stoffschranks	Die Oberfläche der Platte ist gebrochen, zerkratzt oder es fehlen einige Schraubenlöcher.	Sie können uns kontaktieren und wir werden uns innerhalb von 24 Stunden bei Ihnen melden. Oder Sie erreichen uns per After-Sales-E-Mail.
	Die Schraubenlöcher auf der Platte und dem Stahlrahmen der Oberfläche stimmen nicht überein.	<ol style="list-style-type: none"> Bitte ziehen Sie die Schrauben auf der Platte zu 70% an, ziehen Sie sie nicht vollständig an. Passen Sie die Platte und den Stahlrahmen an, bis die Schraubenlöcher übereinstimmen, dann ziehen Sie alle Schrauben fest.
	Der Stoffschrank ist uneben oder nicht fest genug, es gibt Lücken nach dem Zusammenbau.	<ol style="list-style-type: none"> Lösen Sie die Schrauben an den unebenen oder lückenhaften Stellen; justieren Sie, bis die Tischplatten flach und fest sind, und ziehen Sie dann die Schrauben fest. Wenn Ihr Problem weiterhin nicht gelöst werden kann, kontaktieren Sie uns bitte.
Stahlrahmen	Der Stoffschrank ist uneben oder nicht fest genug, es gibt Lücken nach dem Zusammenbau	Sie können uns kontaktieren und wir werden uns innerhalb von 24 Stunden bei Ihnen melden. Oder Sie erreichen uns per After-Sales-E-Mail.
	Das Produkt ist nach dem Zusammenbau instabil.	<ol style="list-style-type: none"> Überprüfen Sie, ob die Schrauben festgezogen sind. Lesen Sie das Handbuch sorgfältig durch und überprüfen Sie, ob Teile falsch installiert oder fehlende montiert sind. Wenn Ihr Problem weiterhin nicht gelöst werden kann, kontaktieren Sie uns bitte.
	Nicht durch den Menschen verursachte Schäden während der Nutzung.	Wenn das Produkt aus nicht menschlichen Gründen beschädigt ist, behalten Sie bitte das Produkt und senden Sie uns Fotos davon. Wir werden die Ursache des Schadens innerhalb von 48 Stunden feststellen und Ihnen eine zufriedenstellende Lösung bieten.
Schublade	Gebrochen, schmutzig oder fehlend.	Sie können uns kontaktieren und wir werden uns innerhalb von 24 Stunden bei Ihnen melden. Oder Sie erreichen uns per After-Sales-E-Mail.

WARNING



Children have died from furniture tip over. To reduce the risk of furniture tip over:

- ALWAYS** install tip over restraint provided.
- NEVER** allow children to stand, climb or hang on drawers, doors, or shelves.
- NEVER** open more than one drawer at a time.
- Place heaviest items in the lowest drawers.