

# VEVOR®

TOUGH TOOLS, HALF PRICE

Technical Support and E-Warranty Certificate [www.vevor.com/support](http://www.vevor.com/support)

## MINI SPLIT STAND

MODEL: E043C-H、E043C-1、E045C-H

We continue to be committed to provide you tools with competitive price. "Save Half", "Half Price" or any other similar expressions used by us only represents an estimate of savings you might benefit from buying certain tools with us compared to the major top brands and does not necessarily mean to cover all categories of tools offered by us. You are kindly reminded to verify carefully when you are placing an order with us if you are actually Saving Half in comparison with the top major brands.

# VEVOR®

TOUGH TOOLS, HALF PRICE

## MINI SPLIT STAND

MODEL: E043C-H、E043C-1、E045C-H



<Picture Only For Reference >

### NEED HELP? CONTACT US!

Have product questions? Need technical support? Please feel free to contact us:

**Technical Support and E-Warranty Certificate**  
[www.vevor.com/support](http://www.vevor.com/support)

This is the original instruction, please read all manual instructions carefully before operating. VEVOR reserves a clear interpretation of our user manual. The appearance of the product shall be subject to the product you received. Please forgive us that we won't inform you again if there are any technology or software updates on our product.

### IMPORTANT SAFEGUARDS



**WARNING:** Read and understand this entire manual before operating or servicing this product. Failure to follow these warnings and instructions can cause personal injury or damage to valuable property. Avoid children using the product. And this product is not a toy. Do not allow children to play.

#### TECHNICAL PARAMETER

product name	Mini Split Stand		
Model	<b>E043C-H</b>	<b>E043C-1</b>	<b>E045C-H</b>
Product size(mm)	850*430*600	850*430*400	1000*550*600
Max load(kg/lbs)	200/441	200/441	300/661

#### PACKAGE LIST

No.	Name	Picture	QTY
A	Frame		1
B	Vertical pole		4

C	Support pole		2
D	Base		4
E	Bolt: M8*25mm		4
F	Self-locking nut: M8		12
G	Cap nut: M8		8
H	Spring washer: M8		8
I	Washer: M8		24
J	open end wrench: 10-13		2
K	Bolt: M8*16mm		4
L	Expansion screws: M8*70		4
N	Buffer pad		4
M	Manual		1

**ASSEMBLY INSTRUCTIONS**

Step1: Insert the foot plate into the vertical pole(B) and install the fasteners.

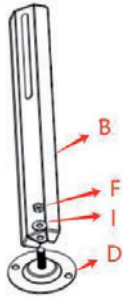

Step2: Repeat step1, finish the installation of vertical poles(B).



Step3: Install the frame(A) with 4 vertical poles.

- 4 -

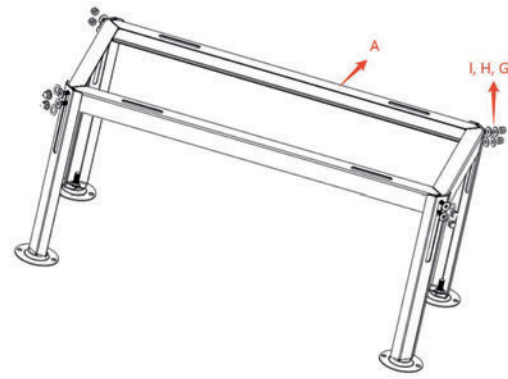

Step4: Install support poles(C) on the frame.

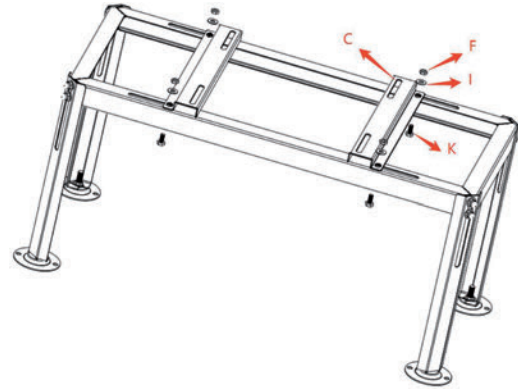

Step5: Put the buffer pad(N) onto the support pole, fasten the AC on the buffer pad.

- 5 -



Step6: Confirm the installation position and mark the hole positions, then drill holes. Hammer the plastic tube of the expansion screw(L) into the hole. Lock the expansion screw with the base.

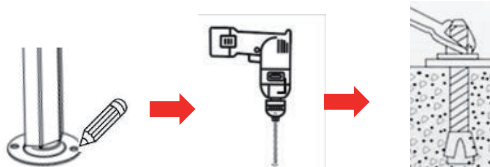

- 6 -

**Manufacturer:** Shanghai muxinmuyeyouxiangongsi

**Address:** Shuangchenglu 803nong11hao1602A-1609shi, baoshanqu, shanghai 200000 CN.

**Imported to AUS:** SIHAO PTY LTD. 1 ROKEVA STREET EASTWOOD NSW 2122 Australia

**Imported to USA:** Sanven Technology Ltd. Suite 250, 9166 Anaheim Place, Rancho Cucamonga, CA 91730

UK	REP
----	-----

YH CONSULTING LIMITED.  
C/O YH Consulting Limited Office 147,  
Centurion House, London Road,  
Staines-upon-Thames, Surrey, TW18 4AX

EC	REP
----	-----

E-CrossStu GmbH  
Mainzer Landstr.69,  
60329 Frankfurt am Main.

**VEVOR®**

**TOUGH TOOLS, HALF PRICE**

Technical Support and E-Warranty Certificate

[www.vevor.com/support](http://www.vevor.com/support)